



2XU

41-2021

SEASONAL WORKBOOK

WELCOME

LE

BRAND INTRODUCTION

SEASONAL OVERVIEW

CORE COLLECTION

PREPARE – Training

PERFORM – Running, Endurance

RECOVER – Recovery, Transit

ACCESSORIES

SALES SUPPORT

APPENDIX

ZXU

OUR
PURPOSE





**TOGETHER
AT 2XU,
WE ARE
GOING TO
CREATE
A FITTER,
HEALTHIER
WORLD.**

**THE COMPLETE
ATHLETE
SYSTEM**

The athlete is at the core of our design process. We are the only brand that caters for the complete athlete system - from preparation and reducing injury through to increasing performance and improving recovery. This is the Two-Times-You promise.



ALL LEVELS
OF ATHLETIC
ABILITY

You deserve the best. Whether you are a weekend warrior looking to improve your overall health and fitness, or an athlete chasing Olympic gold, innovation, technology and performance are always at the forefront of our minds.

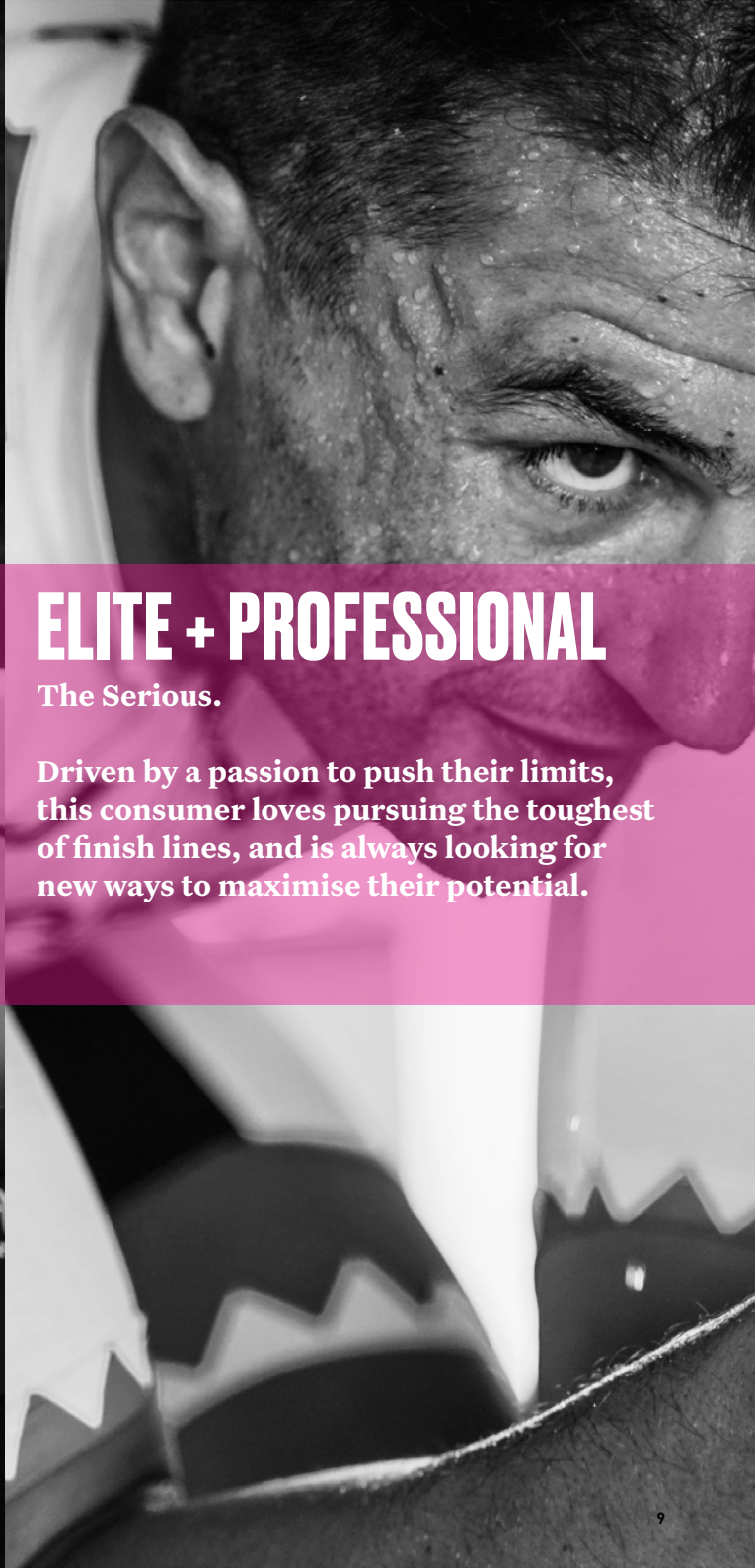
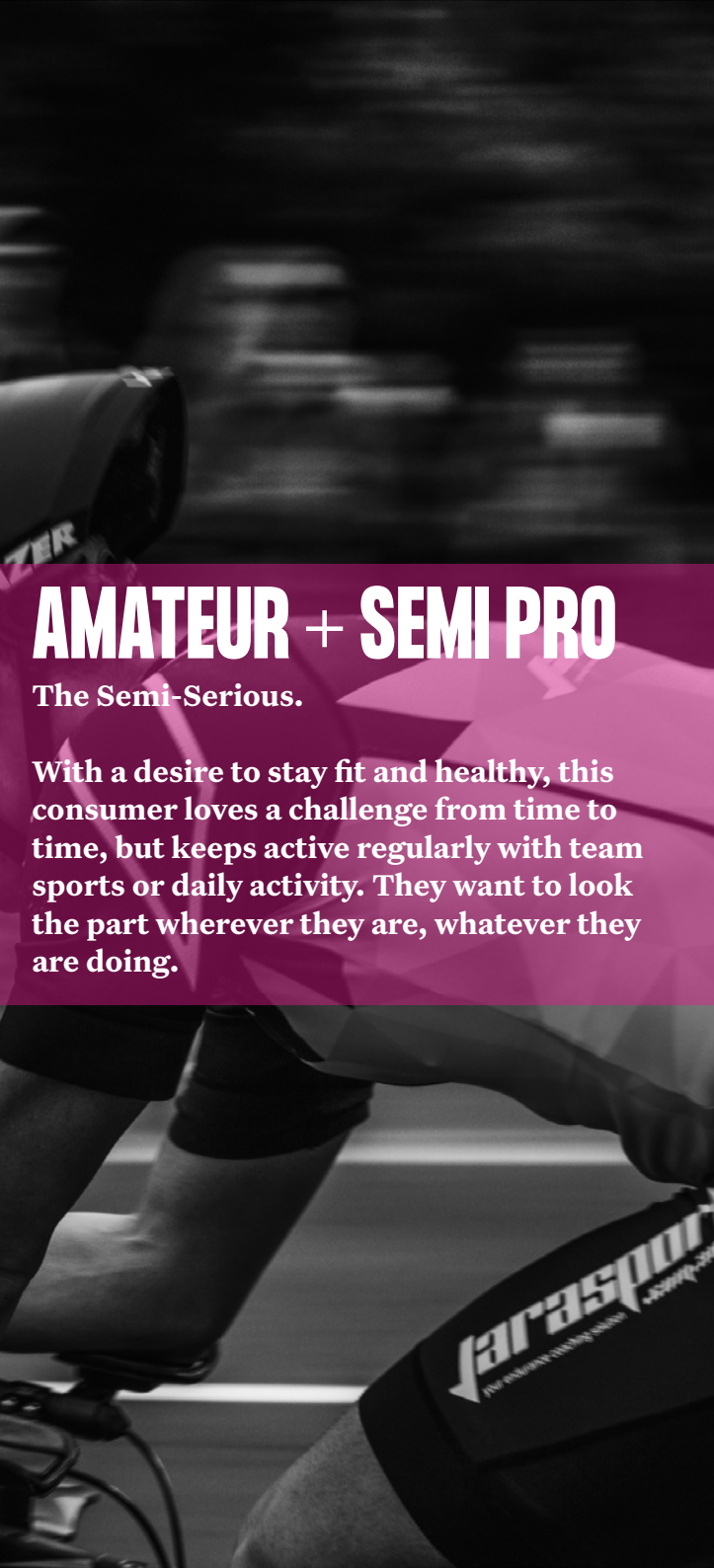
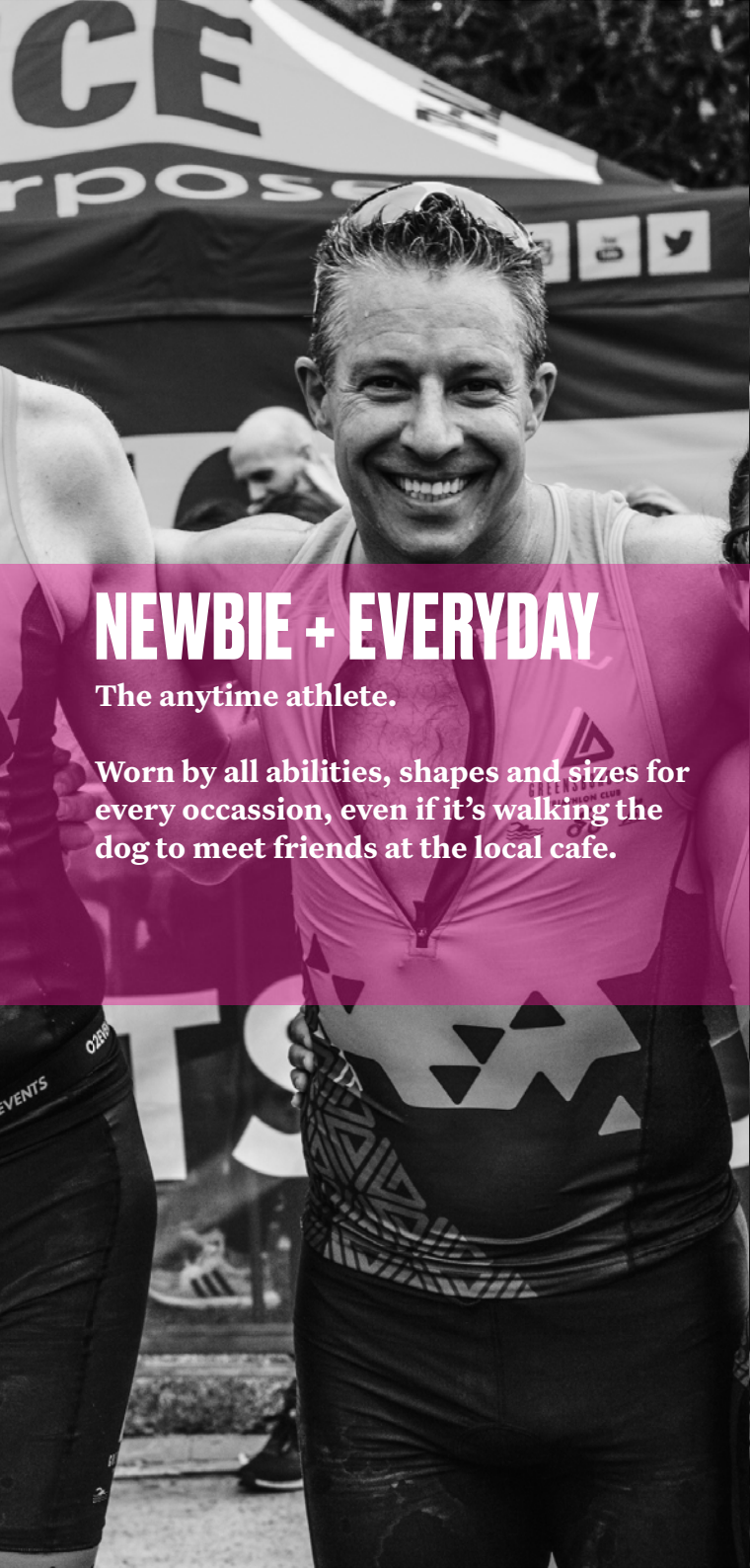

NEWBIE + EVERYDAY

The anytime athlete.

Worn by all abilities, shapes and sizes for every occasion, even if it's walking the dog to meet friends at the local cafe.

AMATEUR + SEMI PRO

The Semi-Serious.

With a desire to stay fit and healthy, this consumer loves a challenge from time to time, but keeps active regularly with team sports or daily activity. They want to look the part wherever they are, whatever they are doing.

ELITE + PROFESSIONAL

The Serious.

Driven by a passion to push their limits, this consumer loves pursuing the toughest of finish lines, and is always looking for new ways to maximise their potential.

COLLECTION
NAMING
SYSTEM

A new collection naming system that allows us to segment our range not only across the athlete lifecycle, apply our various technologies across ranges and at the same time easily communicate a way for consumers to navigate our ranges.

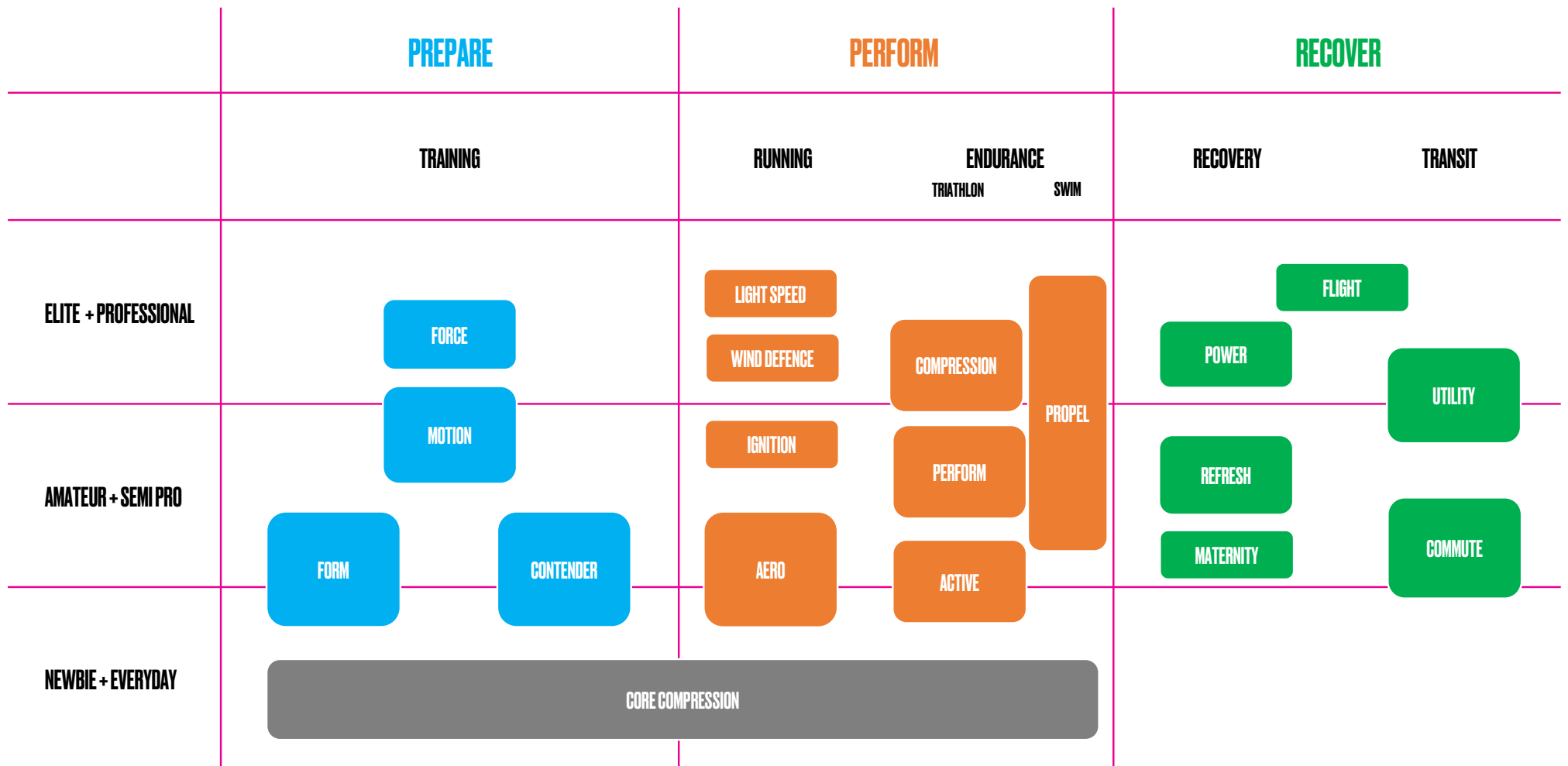

PRODUCT KEY

MCS

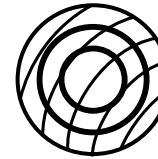

MCS (Muscle Containment Stamping) is a revolutionary fabric support system that traces over key muscle, tendon and fascia groups to provide greater compression power, reducing muscle oscillation and micro-tears and hence limiting fatigue and strain during intensive exercise. New for H1 21, we have leveraged learnings from our MCS technology to launch 2XU's first 3D printed training capsule, combining functional silicon bonding and 3D filament in textile prints to add support in place of distracting elastics and underwires.

X-VENT



Combining a moisture wicking double-knit constructed main with a square mesh back panel, X-VENT technology ensures our run Aero capsule rapidly wicks sweat away from the skin while enhancing breathability and ventilation

X-LITE

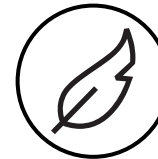

Using a puffed construction for near-weightless performance, X-LITE ensures our Light Speed run capsule tops provide exceptional moisture wicking, reflect UV rays (UPF 50+) while the textured construction stops the fabric clinging to the body even in humid conditions. New for H1 21, we have strategically engineered zones of ventilation into the Light Speed Tech capsule using this fabric to keep you cool where you need it the most.

X-DRY



With a natural fibre hand-feel, X-DRY fabric has superior moisture wicking qualities, dries four times faster than cotton and has an odour neutraliser embedded at yarn level to keep your fresher for longer between washes, reducing your environmental footprint.

X-LOCK

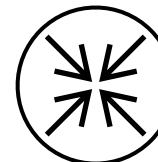

Leveraged across our Vectr sock capsule, X-LOCK technology provides advanced arch and plantar fascia support, and keeps the foot in place within the sock to reduce blistering.

X-HEAT

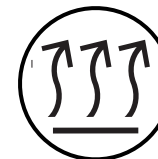

X-HEAT fabric with carbon nano technology warms you up quickly, while ceramic infused yarns omit far infrared rays to maintain a comfortable body temperature in cold conditions. Used in our Ignition capsule, the fabric structure has zero static cling, superior moisture management and a naturally occurring antibacterial and anti-odour feature to keep you fresher for longer between washes, reducing your environmental footprint.



RECYCLABLE MATERIAL USAGE



ECO-MATERIAL USAGE



REFLECTIVE



FOUR-WAY STRETCH



COLD CONDITIONS



WET CONDITIONS



MILD CONDITIONS



HOT CONDITIONS

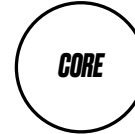

CORE COLLECTION - BASE RANGE



FROM PREVIOUS SEASON - NO CHANGE TO COLOUR, FABRIC OR STYLE



FROM PREVIOUS SEASON - UPDATED WITH COLOUR



SUPERSEED A PREVIOUS STYLE THROUGH FABRIC OR TECH UPDATE



COMPLETELY NEW STYLE



SPECIAL MAKE-UP + LIMITED

ZXU



S
W

SEASONAL

WINTER

KEY INITIATIVES

An always-on approach to messaging across the season - key seasonal product stories, refreshed brand campaign messaging and content allows us to create newness in market constantly.

	FEB	MAR	APR	MAY	JUN
BRAND FOCUS	NEW FINISH LINES <i>A new year means new goals and new finish lines to chase and cross for all of us no matter how big or small they are.</i>	THE STORY OF FINISH LINES <i>Behind the scenes stories from finish lines across the globe - the history, the emotion and the prestige.</i>	COMMUNITIES CHASING FINISH LINES <i>Stories from our community, our events and our athletes as they cross finish lines across the globe</i>		
MONTHLY FOCUS + MESSAGING	PREPARE - PERFORM - RECOVER THE COMPLETE ATHLETE SYSTEM NEW SEASON HIGHLIGHTS	PERFORM - RUNNING MOVE AT LIGHT SPEED LIGHT SPEED + LIGHTSPEED TECH	PERFORM - RUNNING AGAINST THE ELEMENTS WARMTH + VENTILATION	RECOVER - TRANSIT RECOVERY IS TRAINING COMMUTE + UTILITY	PREPARE - TRAINING FREEDOM IN MOTION MOTION TECH + MOTION
KEY PRODUCT STORIES	 <p>TRAINING - MOTION</p>  <p>TRAINING - TECH</p>  <p>RUNNING - LIGHTWEIGHT</p>  <p>RUNNING - VENTILATION</p>	   	   	   	   
SALES PROGRAMS	SEASON LAUNCH	LIGHT SPEED BUNDLE (MEN'S)	VECTR SOCKS BUNDLE (UNISEX)	MOTION BUNDLE (WOMEN'S)	

ATHLETES + AMBASSADORS

From seasoned professionals to up-and-coming stars, our athletes are driven by a relentless pursuit of personal finish lines. They all have bold ambition but at the core they aim to inspire the community around them.



TERENZO BOZZONE



CAM BROWN



AARON ROYLE



MARCEL WALKINGTON



CLARA SMITH



TAYLA BILLINGTON



EMMA CARNEY + EMMA HOGAN



HEATH MELDRUM



BRENT MCMAHON



CLINT KIMMINS



MATT HAUSER



LEVI MAXWELL

KEY PARTNERSHIPS

Through our partnerships across events and organizations we are able to engage and support the community across all levels of participation and also gain valuable insights into product development and performance in-field acrossing triathlon, running, training and high performance.



Fitness First



COLOUR STORIES - WOMEN'S

Base/Core

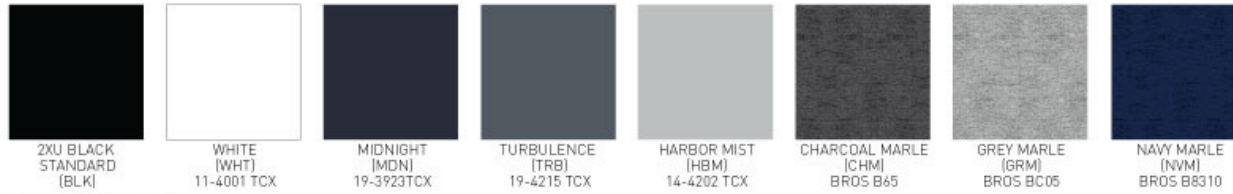

Drop 1 Key Colours:

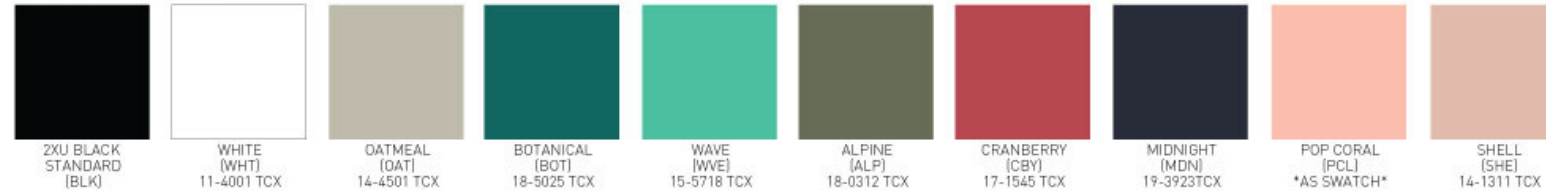

Highlight Colours

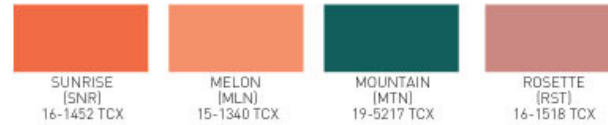

Drop 2 Key Colours:

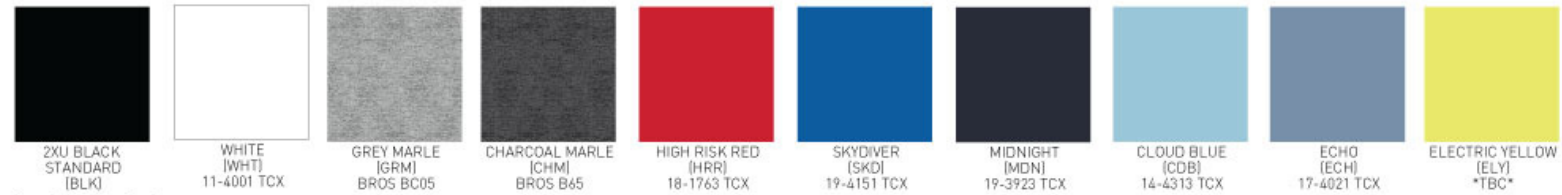

Highlight Colours

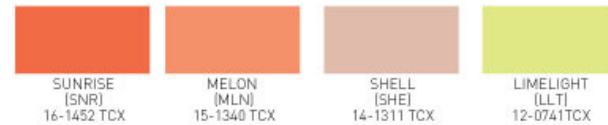

Prints

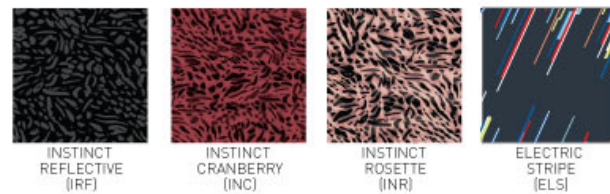

Reflective Colours:



Base/Core

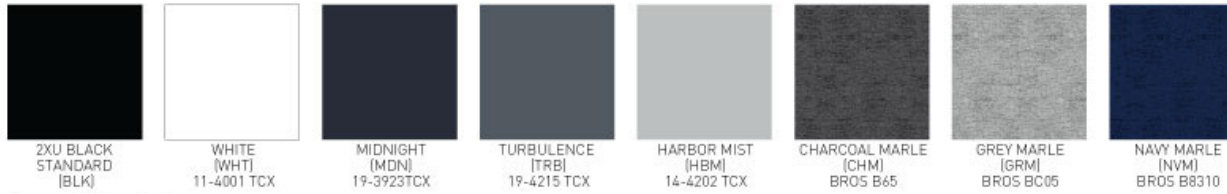

Drop 1 Key Colours:

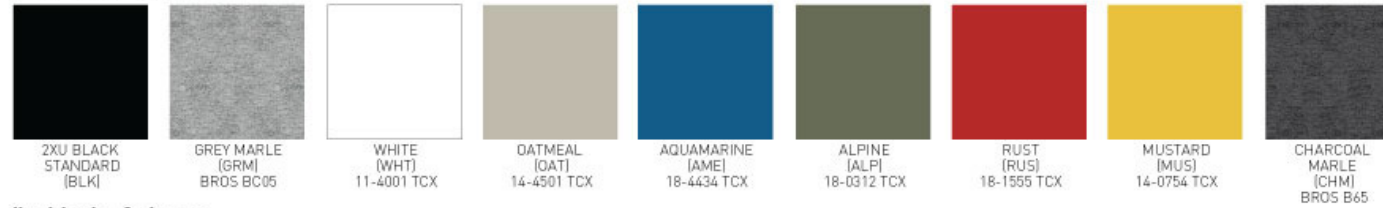

Highlight Colours



Drop 2 Key Colours:



Highlight Colours

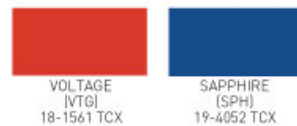

Prints

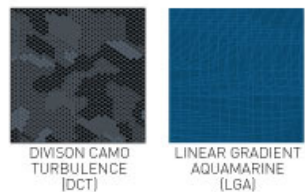

Reflective Colours:



WOMENS RANGEBOARD – H1-2021



WA4173B CORE COMP TIGHTS | BLK/SIL



WA4173B CORE COMP TIGHTS | BLK/NRO

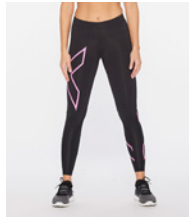

WA4173B CORE COMP TIGHTS | BLK/FLP

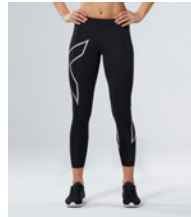

WA4174B CORE COMP 7/8 TIGHTS | BLK/SIL

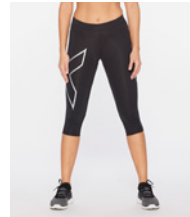

WA4175B CORE COMP 3/4 TIGHTS | BLK/SIL

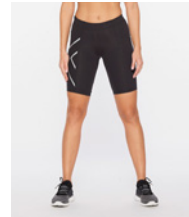

WA4176B CORE COMP SHORT | BLK/SIL



WA4176B CORE COMP SHORT | BLK/NRO



WA4481B CORE COMP 9 INCH SHORTS | BLK/SIL



WA4480B CORE COMP 9 INCH GAME DAY SHORTS | BLK/SIL



WA4480B CORE COMP 9 INCH GAME DAY SHORTS | BGE/SIL



WA4401B CORE COMP L/S | BLK/SIL



WR4652B MOTION TECH L/S | GRM/GRM



WR4652B MOTION TECH L/S | SHE/RST



WR4651B MOTION TECH SINGLET | GRM/GRM



WR4651B MOTION TECH SINGLET | SHE/RST

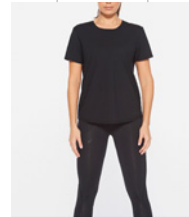

WR4154B MOTION MESH TEE | BLK/BLK



WR4154B MOTION MESH TEE | CRW/RST



WR4154B MOTION MESH TEE | BOT/MTN

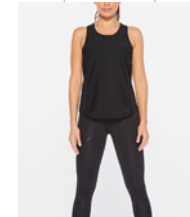

WR4164B MOTION MESH TANK | BLK/BLK



WR4164B MOTION MESH TANK | CRW/RST

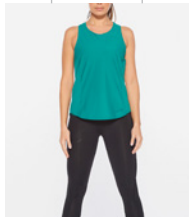

WR4164B MOTION MESH TANK | BOT/MTN



WR4659B MOTION RACERBACK CROP | BLK/BOT

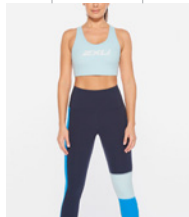

WR4659B MOTION RACERBACK CROP | CBD/WHT

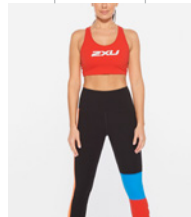

WR4659B MOTION RACERBACK CROP | HRR/WHT

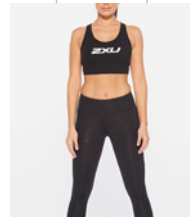

WR4659B MOTION RACERBACK CROP | BLK/WHT

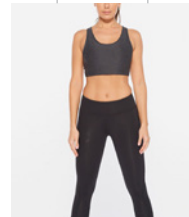

WR4659B MOTION RACERBACK CROP | CBD/BLK



WA4460B MOTION TEXTURE MID-RISE COMP TIGHTS | BLK/BOT



WA4460B MOTION SCULPT HI-RISE COMP TIGHTS | BOT/MTN



WA4357B MOTION PRINT HI-RISE COMP TIGHTS | MDN/WHT



WA4357B MOTION PRINT HI-RISE COMP TIGHTS | CBD/BLK



WA3380B MOTION HI-RISE COMP TIGHTS | BLK/NRO

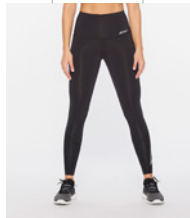

WA3380B MOTION HI-RISE COMP TIGHTS | BLK/SIL

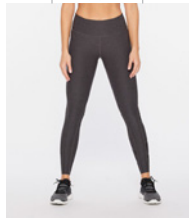

WA3378B MOTION PRINT MID-RISE COMP TIGHTS | CBD/BLK



WA2864B MOTION MID-RISE COMP TIGHTS | BLK/CBY



WA2864B MOTION MID-RISE COMP TIGHTS | BLK/CBD

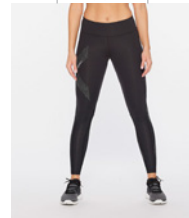

WA2864B MOTION MID-RISE COMP TIGHTS | BLK/DRF



WA2864B MOTION MID-RISE COMP TIGHTS | BLK/OBK



WA3516B MOTION MID-RISE COMP 7/8 TIGHTS | BLK/DRF



WA3516B MOTION MID-RISE COMP 7/8 TIGHTS | BLK/OBK



WA3027B MOTION MID-RISE COMP SHORT | BLK/OBK



WR4712B MOTION TECH BRA | BLK/TRB



WR4712B MOTION TECH BRA | GRM/WHT



WR472B MOTION TECH TIGHTS | BLK/TRB



WR472B MOTION TECH TIGHTS | GRM/WHT

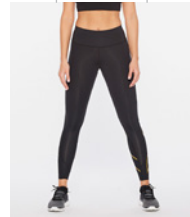

WA5367B FORCE MID-RISE COMP TIGHTS | BLK/GLD

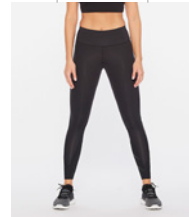

WA5367B FORCE MID-RISE COMP TIGHTS | BLK/NRO

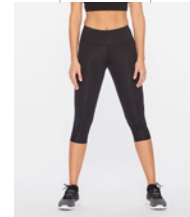

WA5368B FORCE MID-RISE COMP 3/4 TIGHTS | BLK/GLD

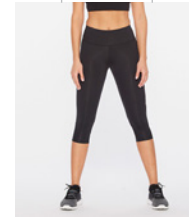

WA5368B FORCE MID-RISE COMP 3/4 TIGHTS | BLK/NRO



WR458B FORM CROP CREW | OAT/OAT



WR458B FORM CROP CREW | BLK/NRR



WR4664 FORM CROP TEE WHT/BLK



WR4664 FORM CROP TEE OAT/WHT



WR4664 FORM CROP TEE RST/SHE



WR4524 FORM SINGLET BLK/BLK



WR4524 FORM SINGLET ALP/BLK

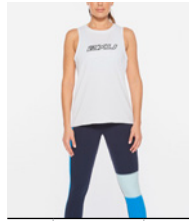

WR4704 FORM TANK WHT/BLK



WR4704 FORM TANK GRM/WHT

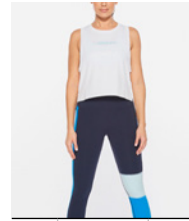

WR4492 FORM CROP TANK WHT/WHT

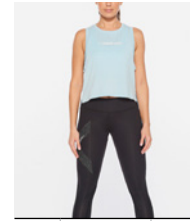

WR4492 FORM CROP TANK CBD/CBD

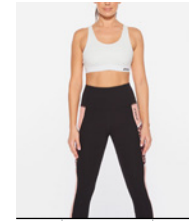

WR4474 FORM STRAPPY CROP WHT/BLK

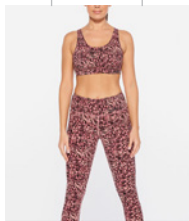

WR4474 FORM STRAPPY CROP INR/BLK



WA4736 FORM BLOCK HI-RISE COMP TIGHTS MDN/WHT



WA4736 FORM BLOCK HI-RISE COMP TIGHTS BLK/HRR



WA4688 FORM SPLICED HI-RISE COMP TIGHTS INR/RST



WA4536 FORM LINEUP HI-RISE COMP TIGHTS BLK/BLK

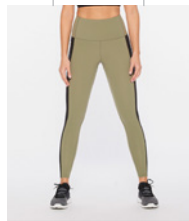

WA4536 FORM LINEUP HI-RISE COMP TIGHTS ALP/BLK



WA4106 FORM STASH HI-RISE COMP TIGHTS BLK/WHT



WA3826 FORM HI-RISE COMP TIGHTS BLK/BLK



WA3836 FORM HI-RISE COMP 7/8 TIGHTS BLK/BLK



WA4546 FORM LINEUP HI-RISE BIKE SHORTS BLK/BLK



WA41616 FORM STASH HI-RISE BIKE SHORTS BLK/BLK

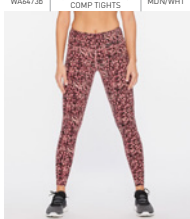

WA3976 FORM PRINT MID-RISE COMP TIGHTS INR/BLK



WA41776 FORM MID-RISE COMP TIGHTS BLK/SIL



WA41786 FORM MID-RISE COMP 7/8 TIGHTS BLK/SIL

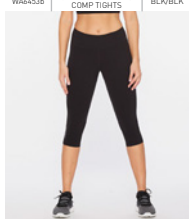

WA3886 FORM MID-RISE COMP 3/4 TIGHTS BLK/SIL

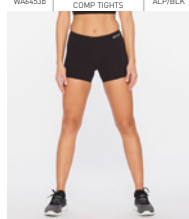

WA44826 FORM MID-RISE COMP 4 INCH SHORTS BLK/SIL

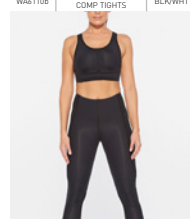

WR4484 BREZZE MESH CROP BLK/BLK

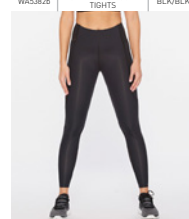

WR4476 BREZZE MESH HI-RISE TIGHTS BLK/BLK

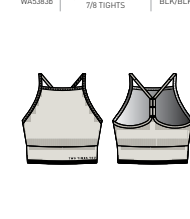

WR44626 ENGINEERED LONGLINE CROP OAT/BLK

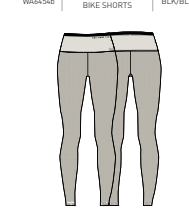

WR44446 ENGINEERED TIGHTS OAT/BLK

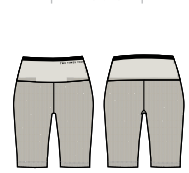

WR4438 ENGINEERED SHORTS OAT/BLK

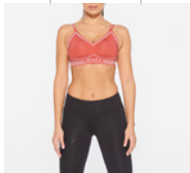

WR44554 NO DISTRACTION CROP CRN/RST

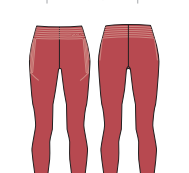

WA44548 NO DISTRACTION HI-RISE COMP TIGHTS CRN/RST



WR45884 IGNITION INSULATION JACKET BLK/BRF



WR45254 IGNITION INSULATION VEST BLK/BRF



WR45624 IGNITION 1/4 ZIP GRM/SRF



WR45624 IGNITION 1/4 ZIP MDN/WRF



WR45624 IGNITION 1/4 ZIP PCL/WRF



WR43424 IGNITION BASE LAYER U/S BLM/SRF

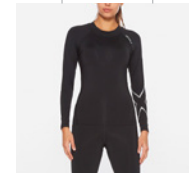

WA44054 IGNITION COMP U/S BLK/SIL

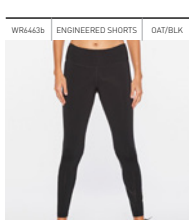

WA43524 IGNITION MID-RISE COMP TIGHTS BLK/NRD

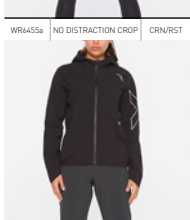

WR45134 LIGHT SPEED WP JACKET BLK/SRF



WR45134 LIGHT SPEED WP JACKET CBV/CBF

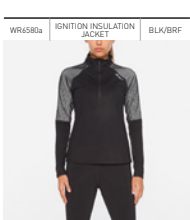

WR45634 LIGHT SPEED 1/2 ZIP BLK/SRF

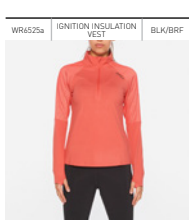

WR45634 LIGHT SPEED 1/2 ZIP CBV/BRF

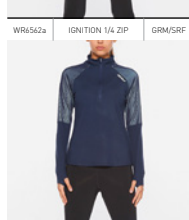

WR45634 LIGHT SPEED 1/2 ZIP MDN/WRF



WR45174 LIGHT SPEED TECH TEE BLK/BRF

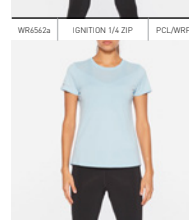

WR45174 LIGHT SPEED TECH TEE CBD/SRF

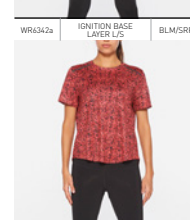

WR45164 LIGHT SPEED TEE INC/BRF

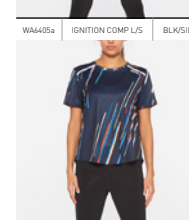

WR45164 LIGHT SPEED TEE ELS/WRF

WOMENS RANGEBOARD – H1-2021



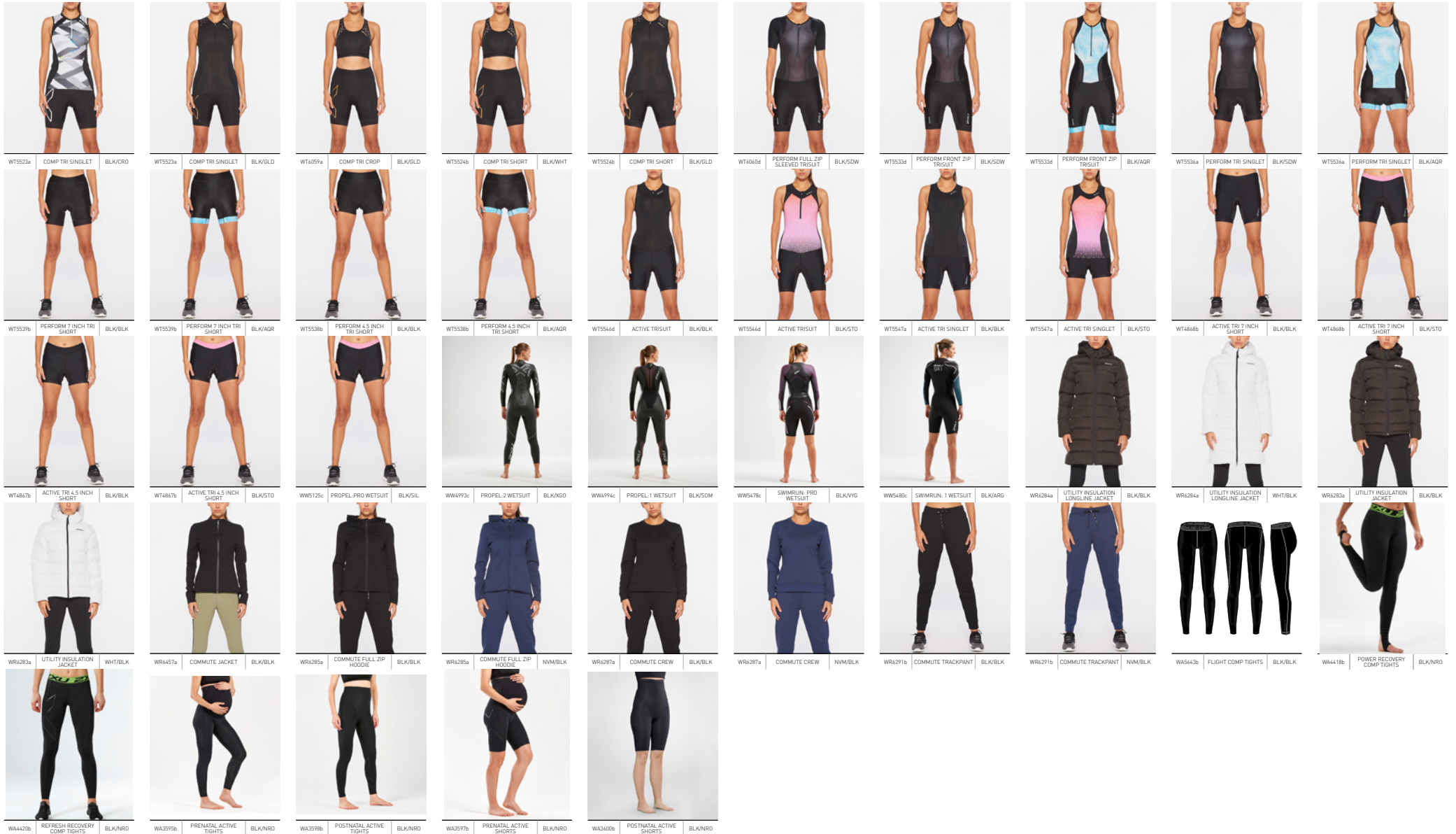

WT5523a	COMP TRI SINGLET	BLK/CRD	WT5523a	COMP TRI SINGLET	BLK/GLD	WT6097a	COMP TRI CROP	BLK/GLD	WT5524b	COMP TRI SHORT	BLK/WHT	WT5524b	COMP TRI SHORT	BLK/GLD	WT6060	PERFORM FULL ZIP SLEEVED TRISUIT	BLK/SDW	WT5533b	PERFORM FRONT ZIP TRISUIT	BLK/SDW	WT5533b	PERFORM FRONT ZIP TRISUIT	BLK/AGR	WT5536a	PERFORM TRI SINGLET	BLK/SDW	WT5536a	PERFORM TRI SINGLET	BLK/AGR
WT5529b	PERFORM 7 INCH TRI SHORT	BLK/BLK	WT5529b	PERFORM 7 INCH TRI SHORT	BLK/AGR	WT5538b	PERFORM 4.5 INCH TRI SHORT	BLK/BLK	WT5538b	PERFORM 4.5 INCH TRI SHORT	BLK/AGR	WT5546b	ACTIVE TRISUIT	BLK/BLK	WT5546b	ACTIVE TRISUIT	BLK/STD	WT5547a	ACTIVE TRI SINGLET	BLK/BLK	WT5547a	ACTIVE TRI SINGLET	BLK/STD	WT4868b	ACTIVE TRI 7 INCH SHORT	BLK/BLK	WT4868b	ACTIVE TRI 7 INCH SHORT	BLK/STD
WT4867b	ACTIVE TRI 4.5 INCH SHORT	BLK/BLK	WT4867b	ACTIVE TRI 4.5 INCH SHORT	BLK/STD	WW5125c	PROPEL-PRO WETSUIT	BLK/SL	WW4993c	PROPEL 2 WETSUIT	BLK/NGD	WW4994c	PROPEL 1 WETSUIT	BLK/SDM	WW5478c	SWIMRUN PRO WETSUIT	BLK/YVD	WW5480c	SWIMRUN 1 WETSUIT	BLK/ARG	WR6284b	UTILITY INSULATION LONGLINE JACKET	BLK/BLK	WR6284b	UTILITY INSULATION LONGLINE JACKET	WHT/BLK	WR6283a	UTILITY INSULATION JACKET	BLK/BLK
WR6283a	UTILITY INSULATION JACKET	WHT/BLK	WR457a	COMMUTE JACKET	BLK/BLK	WR6285a	COMMUTE FULL ZIP HOODIE	BLK/BLK	WR6285a	COMMUTE FULL ZIP HOODIE	NM/BLK	WR6287a	COMMUTE CREW	BLK/BLK	WR6287a	COMMUTE CREW	NM/BLK	WR6291b	COMMUTE TRACKPANT	BLK/BLK	WR6291b	COMMUTE TRACKPANT	NM/BLK	WA5643b	FLIGHT COMP TIGHTS	BLK/BLK	WA4418b	POWER RECOVERY COMP TIGHTS	BLK/NRD
WA4420b	REFRESH RECOVERY COMP TIGHTS	BLK/NRD	WA3595b	PRENATAL ACTIVE TIGHTS	BLK/NRD	WA3598b	POSTNATAL ACTIVE TIGHTS	BLK/NRD	WA3597b	PRENATAL ACTIVE SHORTS	BLK/NRD	WA3600b	POSTNATAL ACTIVE SHORTS	BLK/NRD															

MENS RANGEBOARD — H1-2021



MA3847B CORE COMP TIGHTS BLK/SIL

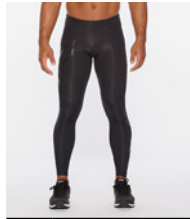

MA3847B CORE COMP TIGHTS BLK/NRO

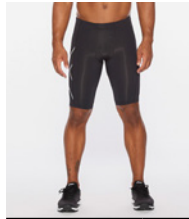

MA3851B CORE COMP SHORTS BLK/SIL

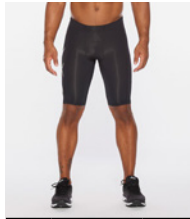

MA3851B CORE COMP SHORTS BLK/NRO

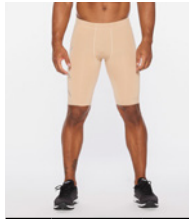

MA3851B CORE COMP SHORTS BGE/SIL

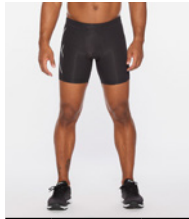

MA4588B CORE COMP 1/2 SHORTS BLK/SIL

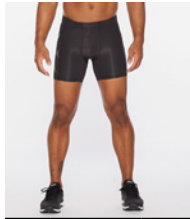

MA4588B CORE COMP 1/2 SHORTS BLK/NRO



MA4588B CORE COMP 1/2 SHORTS BGE/SIL

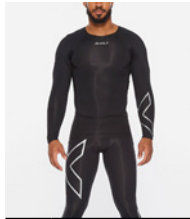

MA4396B CORE COMP L/S BLK/SIL

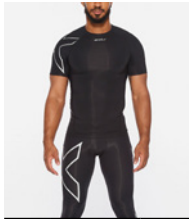

MA4397B CORE COMP S/S BLK/SIL

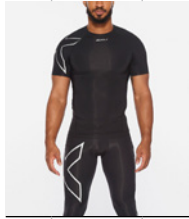

MA4399B CORE COMP S/S BLK/SIL

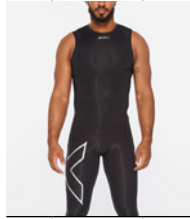

MA4400B CORE COMPRESSION SLEEVELESS BLK/SIL

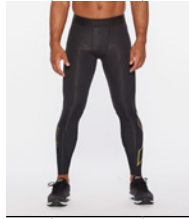

MA3358B FORCE COMP TIGHTS BLK/OLD

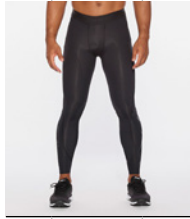

MA3358B FORCE COMP TIGHTS BLK/NRO

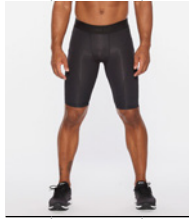

MA3366B FORCE COMP SHORTS BLK/OLD



MA4488A MOTION TECH L/S GRM/GRM



MA4488A MOTION TECH L/S SAP/ECH

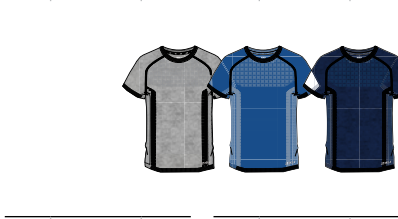

MA4487A MOTION MESH TEE GRM/GRM



MA4487A MOTION MESH TEE NVM/NVM



MA4487A MOTION MESH TEE SAP/ECH



MR4477B MOTION COLOUR BLOCK TEE AME/BLK



MR4477B MOTION COLOUR BLOCK TEE ALP/BLK



MR4475B MOTION TEE BLK/CRF



MR4475B MOTION TEE AME/BLK



MR4476B MOTION TANK BLK/CRF



MR4476B MOTION TANK AME/BLK



MR4476B MOTION TANK ALP/BLK



MR4479B MOTION 8' SHORTS BLK/BLK

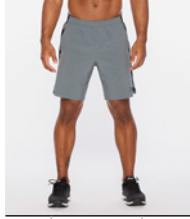

MR4479B MOTION 8' SHORTS TRB/BLK



MR4479B MOTION 8' SHORTS MDN/AME



MR4478B MOTION 5' SHORTS BLK/BLK



MR4478B MOTION 5' SHORTS TRB/BLK



MR4478B MOTION 5' SHORTS MDN/AME



MA4489B MOTION COMP TIGHTS BLK/NRO



MA4489B MOTION COMP TIGHTS MDN/NRO

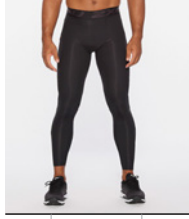

MA4489B MOTION COMP TIGHTS BLK/CRF



MA4488B MOTION COMP SHORTS BLK/NRO



MA4488B MOTION COMP SHORTS MDN/NRO



MA4488B MOTION COMP SHORTS BLK/CRF



MR4480B CONTENDER WINDBREAKER TRB/BLK



MR4490B CONTENDER COLOUR BLOCK CREW SAP/LLT



MR4481B CONTENDER CREW OAT/BLK



MR4483B CONTENDER TEE BLK/BLK



MR4483B CONTENDER TEE WH1/WH1



MR4483B CONTENDER TEE RUS/RUS



MR4483B CONTENDER TEE WH1/SAP



MR4482B CONTENDER TANK OAT/BLK



MR4482B CONTENDER TANK RUS/BLK



MR4482B CONTENDER TANK WH1/SAP



MR4510B IGNITION INSULATION JACKET BLK/BRF



MR5112 IGNITION INSULATION VEST BLK/BRF



MR5554 LIGHT SPEED 1/2 ZIP BLK/SRF



MR5503 LIGHT SPEED SINGLET DCT/BRF



MR5574 AERO TEE RUS/BRF



MR5574 AERO SINGLET BLK/SRF



MR5544 IGNITION 1/4 ZIP TRB/BRF



MR5554 LIGHT SPEED 1/2 ZIP TRB/BRF



MR5507 LIGHT SPEED JOGGER BLK/BRF



MR5574 AERO JACKET BLK/SRF



MR5584 AERO TANK BLK/SRF



MR5544 IGNITION 1/4 ZIP ALP/KRF



MR5555 LIGHT SPEED 1/2 ZIP AME/BRF



MR5505 LIGHT SPEED 7-COVER SHORTS BLK/BRF



MR5574 AERO JACKET ALP/KRF



MR5584 AERO TANK WH7/SRF



MR5544 IGNITION 1/4 ZIP MDN/SRF



MR5503 LIGHT SPEED TECH TEE BLK/BRF



MR5504 LIGHT SPEED 3-SHORTS BLK/BRF



MR5574 AERO JACKET ELV/BRF



MR5584 AERO TANK ALP/KRF



MR6340 IGNITION BASE LAYER L/S BLK/SRF



MR5503 LIGHT SPEED TECH TEE ECH/BRF



MR5504 LIGHT SPEED 3-SHORTS DCT/BRF



MR5564 AERO L/S BLK/SRF



MR5584 AERO TANK QAT/BRF

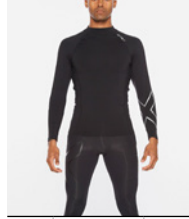

MA4404 IGNITION COMP L/S BLK/SIL



MR5502 LIGHT SPEED TEE LG4/BRF

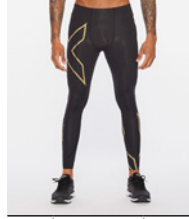

MAS305 LIGHT SPEED COMP TIGHTS BLK/SRF



MR5564 AERO L/S RUS/BRF



MR5584 AERO TANK RUS/BRF



WR4702 IGNITION COMP TIGHTS BLK/WRD



MR5502 LIGHT SPEED TEE DCT/BRF



MAS305 LIGHT SPEED COMP TIGHTS BLK/BRF



MR5574 AERO TEE BLK/SRF



MR5574 AERO SINGLET BLK/SRF

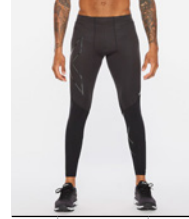

MA4310 WIND DEFENCE COMP TIGHTS BLK/SGR

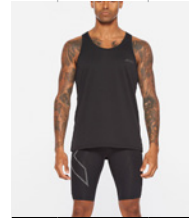

MR5501 LIGHT SPEED TECH SINGLET BLK/BRF



MAS305 LIGHT SPEED COMP TIGHTS BLK/BRF



MR5574 AERO TEE WH7/SRF



MR5574 AERO SINGLET RUS/BRF



MR4974 LIGHT SPEED WP JACKET BLK/SRF



MR5501 LIGHT SPEED TECH SINGLET ECH/BRF

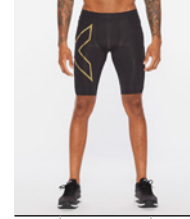

MAS310 LIGHT SPEED COMP SHORTS BLK/SRF



MR5574 AERO TEE ALP/KRF



MR5574 AERO SINGLET ALP/KRF

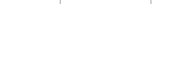

MR4974 LIGHT SPEED WP JACKET AME/ARF



MR5500 LIGHT SPEED SINGLET LG4/BRF



MAS310 LIGHT SPEED COMP SHORTS BLK/BRF



MR5574 AERO TEE QAT/BRF



MR5586 AERO WOVEN JOGGER BLK/SRF



MENS RANGEBOARD — H1-2021





MW5476 | SWIMRUN 1 WETSUIT | BLK/BSG



MR6262 | UTILITY INSULATION JACKET | BLK/BLK



MR6262 | UTILITY INSULATION JACKET | GRN/BLK



MR6268 | COMMUTE FULL ZIP HOODIE | BLK/BLK



MR6268 | COMMUTE FULL ZIP HOODIE | CHM/BLK



MR6272 | COMMUTE CREW | BLK/BLK



MR6272 | COMMUTE CREW | CHM/BLK



MR6273 | COMMUTE TRACKPANT | BLK/BLK



MR6273 | COMMUTE TRACKPANT | CHM/BLK



MR6365 | COMMUTE F SHORTS | BLK/BLK



MR6365 | COMMUTE F SHORTS | CHM/BLK



MA3642 | FLIGHT COMPRESSION TIGHTS | BLK/BLK



MA4417 | POWER RECOVERY COMPRESSION TIGHTS | BLK/NRO



MA4419 | REFRESH RECOVERY COMPRESSION TIGHTS | BLK/NRO

2XU

GOORE

GOOLLECT



ION

PROVEN PERFORMANCE

Developed from relentless testing and proven both on the field and in-market, these are the essential products to build your range around.



MA3849b / WA4173b
Core Compression
Tights

Lightweight & Flexible Support

Powerful, lightweight PWX fabric with circular knit 360-degree stretch, reduces muscle movement and damage whilst maintaining flexibility for ultimate sports performance.

Graduated Compression

Firm graduated compression boosts blood flow to muscles, improving performance, lowering risk of injury and speeding up recovery.

Athletic Waistband

Drawstring waistband provides adjustable secure fit.

Quick-Drying

High quality, durable, moisture-wicking yarns outlast the competition and keep the skin cool and dry.

Garment Features:

1. Full length compression tight
2. PWX highly powerful, lightweight and flexible compression fabric
3. Drawstring waistband for adjustable secure fit
4. Graduated compression for improved circulation
5. Signature X logo on thigh and calf
6. Flatlock seams to reduce chafe

	Men:	Women:
Best For:	Mild Weather	Mild Weather
Colours:	BLK/SIL, BLK/NRO	BLK/SIL, BLK/NRO
Size Range:	XXS, XS, S, ST, M, MT, L, LT, XL, XLT, XXL, XXLT, XXXL	XXS, XS, XST, S, ST, M, MT, L, LT, XL, XXL
Rise:	Regular	Regular
Waistband:	3.5cm covered elastic with drawstring	4cm covered elastic with drawstring
Fabric:	Front: PWX 70D. 72% Nylon, 28% Lycra Back: PWX 105D. 65% Nylon, 35% Lycra	Front: PWX 70D. 72% Nylon, 28% Lycra Back: PWX 160D. 65% Nylon, 35% Lycra

WA4174b
Core Compression
7/8 Tights

Garment Features:

1. 7/8 compression tight
2. PWX highly powerful, lightweight and flexible compression fabric
3. Drawstring waistband for adjustable secure fit
4. Signature X logo on thigh and calf
5. Flatlock seams to reduce chafe

Best For:	Mild Weather
Colours:	BLK/SIL
Size Range:	XXS, XS, XST, S, ST, M, MT, L, LT, XL, XXL
Rise:	Regular
Waistband:	4cm covered elastic with drawstring
Fabric:	Front: PWX 70D. 72% Nylon, 28% Lycra Back: PWX 160D. 65% Nylon, 35% Lycra

MA3850b / WA4175b
Core Compression
3/4 Tights

Garment Features:

1. 3/4 compression tight
2. PWX highly powerful, lightweight and flexible compression fabric
3. Drawstring waistband for adjustable secure fit
4. Signature X logo on thigh
5. Flatlock seams to reduce chafe

	Men:	Women:
Best For:	Mild Weather, Hot Weather	Mild Weather, Hot Weather
Colours:	BLK/SIL	BLK/SIL
Size Range:	XXS, XS, S, ST, M, MT, L, LT, XL, XLT, XXL, XXLT, XXXL	XXS, XS, XST, S, ST, M, MT, L, LT, XL, XXL
Rise:	Regular	Regular
Waistband:	3.5cm covered elastic with drawstring	4cm covered elastic with drawstring
Fabric:	Front: PWX 70D. 72% Nylon, 28% Lycra 2. Back: PWX 105D. 65% Nylon, 35% Lycra	Front: PWX 70D. 72% Nylon, 28% Lycra Back: PWX 160D. 65% Nylon, 35% Lycra



MA3851b / WA4176b
Core Compression
Shorts

Garment Features:

1. Compression short
2. PWX highly powerful, lightweight and flexible compression fabric
3. Drawstring waistband for adjustable secure fit
4. Signature X logo on thigh
5. Flatlock seams to reduce chafe



MA4508b
Core Compression
1/2 Shorts

Garment Features:

1. Compression 1/2 short
2. PWX highly powerful, lightweight and flexible compression fabric
3. Drawstring waistband for adjustable secure fit
4. Signature X logo on thigh
5. Flatlock seams to reduce chafe



WA4481b
Core Compression
5" Shorts

Garment Features:

1. Compression 5" short
2. PWX highly powerful, lightweight and flexible compression fabric
3. Drawstring waistband for adjustable secure fit
4. Signature X logo on thigh
5. Flatlock seams to reduce chafe



WA4480b
Core Compression 5" Game Day
Shorts

Garment Features:

1. Compression 5" short
2. PWX highly powerful, lightweight and flexible compression fabric
3. Drawstring waistband for adjustable secure fit
4. Discreet 2XU logo
5. Flatlock seams to reduce chafe

	Men:	Women:
Best For:	Hot Weather	Hot Weather
Colours:	BLK/SIL, BLK/NRO, BGE/SIL	BLK/SIL, BLK/NRO
Size Range:	XXS, XS, S, M, L, XL, XXL, XXXL	XXS, XS, S, M, L, XL, XXL
Rise:	Regular	Regular
Waistband:	3.5cm covered elastic with drawstring	4cm covered elastic with drawstring
Fabric:	Front: PWX 70D 72% Nylon, 28% Lycra Back: PWX 105D 65% Nylon, 35% Lycra	Front: PWX 70D 72% Nylon, 28% Lycra Back: PWX 105D 65% Nylon, 35% Lycra

Best For:	Hot Weather
Colours:	BLK/SIL, BLK/NRO, BGE/SIL
Size Range:	XXS, XS, S, M, L, XL, XXL, XXXL
Rise:	Regular
Waistband:	3.5cm covered elastic with drawstring
Fabric:	Front: PWX 70D 72% Nylon, 28% Lycra Back: PWX 105D 65% Nylon, 35% Lycra

Best For:	Hot Weather
Colours:	BLK/SIL
Size Range:	XXS, XS, S, M, L, XL, XXL
Rise:	Regular
Waistband:	4cm covered elastic with drawstring
Fabric:	Front: PWX 70D 72% Nylon, 28% Lycra Back: PWX 160D 65% Nylon, 35% Lycra

Best For:	Hot Weather
Colours:	BLK/SIL, BGE/SIL
Size Range:	XXS, XS, S, M, L, XL, XXL
Rise:	Regular
Waistband:	4cm covered elastic with drawstring
Fabric:	Front: PWX 70D 72% Nylon, 28% Lycra Back: PWX 160D 65% Nylon, 35% Lycra



MA6398a / WA6401a
Core Compression
Long Sleeve

Lightweight & Flexible Support

Powerful, lightweight PWX fabric with circular knit 360-degree stretch, reduces muscle movement and damage to the upper body whilst improving postural awareness, increasing performance and reducing risk of injury.

Stay Cool

PWX VENT panels through centre back and under arms improve air flow by almost 200%, increasing evaporation of your sweat to keep you at optimal performance temperature

Quick-Drying

High quality, durable, moisture-wicking yarns outlast the competition and keep the skin cool and dry.



Garment Features:

1. Compression long sleeve top
2. PWX highly powerful, lightweight and flexible compression fabric
3. Compression increases circulation for improved recovery and reduced muscle stiffness post-exercise
4. PWX Vent panels deliver greater breathability in key regions
5. Raglan sleeve construction for unrestricted movement
6. Signature X logo on arm
7. Flatlock seams to reduce chafe

	Men:	Women:
Best For:	Mild Weather	Mild Weather
Colours:	BLK/SIL	BLK/SIL
Size Range:	XS, S, M, L, XL, XXL, XXXL	XS, S, M, L, XL
Fabric:	PWX 70D. 72% Nylon 28% Lycra	PWX 70D. 72% Nylon 28% Lycra



MA6399a
Core Compression
Short Sleeve

Garment Features:

1. Compression short sleeve top
2. PWX highly powerful, lightweight and flexible compression fabric
3. PWX Vent panels deliver greater breathability in key regions
4. Raglan sleeve construction for unrestricted movement
5. Signature X logo on shoulder
6. Flatlock seams to reduce chafe

Best For:	Mild Weather, Hot Weather
Colours:	BLK/SIL
Size Range:	XS, S, M, L, XL, XXL, XXXL
Fabric:	PWX 70D. 72% Nylon 28% Lycra



MA6400a
Core Compression Sleeveless

Garment Features:

1. Compression sleeveless top
2. PWX highly powerful, lightweight and flexible compression fabric
3. PWX Vent panels deliver greater breathability in key regions
4. Flatlock seams to reduce chafe

Best For:	Hot Weather
Colours:	BLK/SIL
Size Range:	XS, S, M, L, XL, XXL, XXXL
Fabric:	PWX 70D. 72% Nylon 28% Lycra



CA2549b (Boys) / CA4158b (Girls)
Core Youth
Compression Tights

Lightweight & Flexible Support

Powerful, lightweight PWX fabric with circular knit 360-degree stretch, reduces muscle movement and damage whilst maintaining flexibility for ultimate sports performance.

Graduated Compression

Firm graduated compression boosts blood flow to muscles, improving performance, lowering risk of injury and speeding up recovery.

Athletic Waistband

Drawstring waistband provides adjustable secure fit.

Quick-Drying

High quality, durable, moisture-wicking yarns outlast the competition and keep the skin cool and dry.



Garment Features:

1. Youth compression tight
2. PWX highly powerful, lightweight and flexible compression fabric
3. Drawstring waistband for adjustable secure fit
4. Graduated compression for improved circulation
5. Signature X logo on thigh and calf
6. Flatlock seams to reduce chafe

	Boys:	Girls:
Best For:	Mild Weather	Mild Weather
Colours:	BLK/BLK, BLK/NRO	BLK/SIL, BLK/BLU, BLK/HPK, BLK/NRO
Size Range:	S, M, L, XL	S, M, L, XL
Rise:	Regular	Regular
Waistband:	3cm covered elastic with drawstring	3cm covered elastic with drawstring
Fabric:	PWX 70D. 72% Nylon 28% Lycra	PWX 70D. 72% Nylon 28% Lycra



CA2548b
Core Youth
Compression Shorts

Garment Features:

1. Youth compression short
2. PWX highly powerful, lightweight and flexible compression fabric
3. Drawstring waistband for adjustable secure fit
4. Signature X logo on thigh
5. Flatlock seams to reduce chafe

	Girls:
Best For:	Hot Weather
Colours:	BLK/BLK, BLK/NRO, BGE/BGE
Size Range:	S, M, L, XL
Rise:	Regular
Waistband:	3cm covered elastic with drawstring
Fabric:	PWX 70D. 72% Nylon 28% Lycra



CA2547b (Boys) / CA4804b (Girls)
Core Youth
Compression 1/2 Shorts

Garment Features:

1. Youth compression 1/2 short
2. PWX highly powerful, lightweight and flexible compression fabric
3. Drawstring waistband for adjustable secure fit
4. Flatlock seams to reduce chafe

	Boys:	Girls:
Best For:	Hot Weather	Hot Weather
Colours:	BLK/BLK, BGE/BGE	BLK/NRO, BLK/SIL, NRV/SIL
Size Range:	S, M, L, XL	S, M, L, XL
Rise:	Regular	Regular
Waistband:	3cm covered elastic with drawstring	3cm covered elastic with drawstring
Fabric:	PWX 70D. 72% Nylon 28% Lycra	PWX 70D. 72% Nylon 28% Lycra

CA6406a

Core Youth Compression Long Sleeve

Lightweight & Flexible Support

Powerful, lightweight PWX fabric with circular knit 360-degree stretch, reduces muscle movement and damage to the upper body whilst improving postural awareness, increasing performance and reducing risk of injury.

Quick-Drying

High quality, durable, moisture-wicking yarns outlast the competition and keep the skin cool and dry.

Garment Features:

1. Compression long sleeve top
2. PWX highly powerful, lightweight and flexible compression fabric
3. Compression increases circulation for improved recovery and reduced muscle stiffness post-exercise
4. Raglan sleeve construction for unrestricted movement
5. Flatlock seams to reduce chafe

Best For: Mild Weather

Colours: BLK/SIL

Size Range: S, M, L, XL

Fabric: PWX 70D. 72% Nylon 28% Lycra

PREPARE

PREP

REDUCE INJURY

Every athlete knows preparation is key for future performance and reducing the risk of injury. You are laying the foundation, building your body's durability and strength.



TRAINING

GO-TO-MARKET

COMPLEMENT YOUR WORKOUT THROUGH FREEDOM OF MOVEMENT, COMFORT AND DURABILITY WITHOUT COMPROMISE ON PERFORMANCE AND TREND.

CONSUMER PROFILE

Our training consumer are those looking to build a solid base for their endurance and running sports, they are seeking the same quality from their workout as they expect from their race day sessions. They understand the importance of quality over quantity and are willing to put the hard work in while no one is watching.

COLLECTIONS GUIDE

FORCE

Smash your goals at every workout with our strongest collection.

MOTION

Engineered to move with your body during the toughest workout.

CONTENDER

Unrivalled everyday comfort.

FORM

All day support, coverage and comfort.

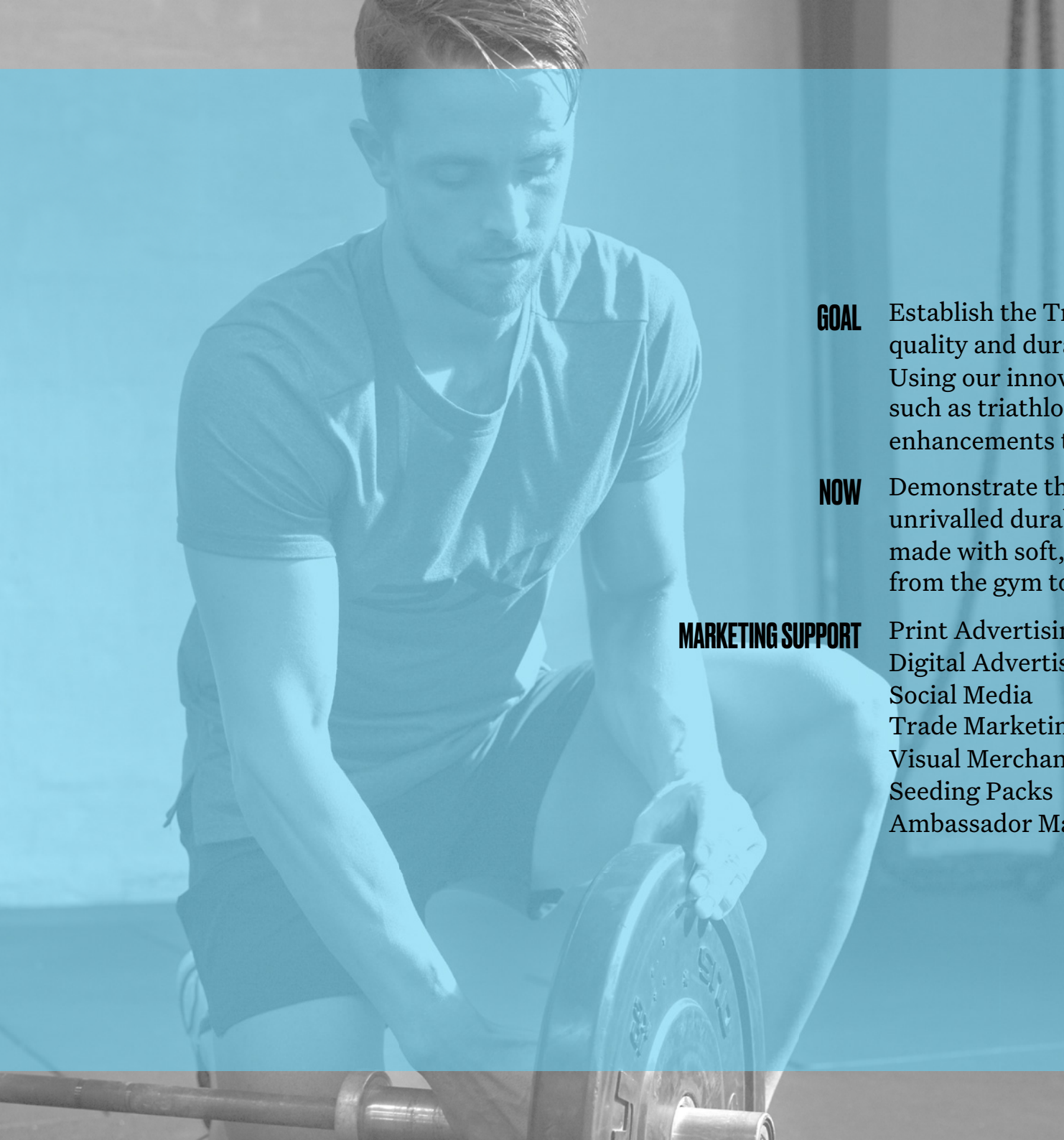

GOAL Establish the Training range to be the go-to for quality and durability, just like our compression. Using our innovations across performance sports such as triathlon and running to bring further enhancements to the range.

NOW Demonstrate the versatility within the range - unrivalled durability for the toughest of workouts made with soft, comfortable fabrics that take you from the gym to the street.

MARKETING SUPPORT

- Print Advertising
- Digital Advertising
- Social Media
- Trade Marketing
- Visual Merchandising
- Seeding Packs
- Ambassador Marketing

Force

The Force Compression Tights with revolutionary Muscle Containment Stamping (MCS) technology are developed with a detailed understanding of the key muscles and movements used during high-intensity training, reducing muscle movement, damage and fatigue so you can smash your goals at every workout.



MA5365b
Force Compression Tights

Garment Features:

1. Full length compression tight
2. Glute MCS
3. Hamstring MCS
4. Quadriceps MCS
5. Calf MCS
6. PWX highly powerful, lightweight and flexible compression fabric
7. Graduated compression for improved circulation
8. Flat jacquard elastic waistband for easy layering
9. Signature X logo on calf
10. Flatlock seams to reduce chafe

Best For:	Mild Weather
Colours:	BLK/GLD, BLK/NRO
Size Range:	XXS, XS, S, ST, M, MT, L, LT, XL, XLT, XXL, XXXL
Rise:	Regular
Waistband:	Jacquard elastic
Fabric:	Front: PWX 70D. 72% Nylon, 28% Lycra Back: PWX 105D. 65% Nylon, 35% Lycra (Power, Weight, Flexibility)



MA5366b
Force Compression Shorts

Garment Features:

1. Compression short
2. Glute MCS
3. Hamstring MCS
4. Quadriceps MCS
5. PWX highly powerful, lightweight and flexible compression fabric
6. Flat jacquard elastic waistband for easy layering
7. Flatlock seams to reduce chafe

Best For:	Hot Weather
Colours:	BLK/GLD
Size Range:	XXS, XS, S, M, L, XL, XXL, XXXL
Rise:	Regular
Waistband:	Jacquard elastic
Fabric:	Front: PWX 70D. 72% Nylon, 28% Lycra Back: PWX 105D. 65% Nylon, 35% Lycra (Power, Weight, Flexibility)

Muscle Containment Stamping (MCS)

Muscle Containment Stamping (MCS) traces glutes, to aid postural awareness for pelvic and lower back stability; hamstrings, to reduce muscle strain during lifts and squats; quadriceps, to lower impact during running, jumping and squatting; and calves, for injuries from accelerating and decelerating phases.

Designed To Be Layered

Flat jacquard elastic waistband delivers a smooth, secure feel and allows for easy layering beneath shorts or joggers if required.

Lightweight & Flexible Support

Powerful, lightweight PWX fabric with circular knit 360-degree stretch, reduces muscle movement and damage whilst maintaining flexibility for ultimate sports performance.

Graduated Compression

Firm graduated compression boosts blood flow to muscles, improving performance, lowering risk of injury and speeding up recovery.

Quick-Drying

High quality, durable, moisture-wicking yarns outlast the competition and keep the skin cool and dry.



WA5367b
Force Mid-Rise Compression
Tights

Garment Features:

1. Full length compression tight
2. Glute MCS
3. Hamstring MCS
4. Quadriceps MCS
5. Calf MCS
6. PWX highly powerful, lightweight and flexible compression fabric
7. Graduated compression for improved circulation
8. Mid-Rise bonded flat waistband for body sculpting secure fit
9. Signature X logo on calf
10. Flatlock seams to reduce chafe

Best For: Mild Weather

Colours: BLK/GLD, BLK/NRO

Size Range: XXS, XS, XST, S, ST, M, MT, L, LT, XL, XXL

Rise: Mid-Rise

Waistband: 8cm flat bonded

Fabric: Front: PWX 70D. 72% Nylon, 28% Lycra
Back: PWX 160D. 65% Nylon, 35% Lycra
(Power, Weight, Flexibility)



WA5368b
Force Mid-Rise Compression 3/4
Tights

Garment Features:

1. 3/4 compression tight
2. Glute MCS
3. Hamstring MCS
4. Quadriceps MCS
5. PWX highly powerful, lightweight and flexible compression fabric
6. Mid-Rise bonded flat waistband for body sculpting secure fit
7. Signature X logo on thigh
8. Flatlock seams to reduce chafe

Best For: Mild Weather,
Hot Weather

Colours: BLK/GLD, BLK/NRO

Size Range: XXS, XS, XST, S, ST, M, MT, L, LT, XL, XXL

Rise: Mid-Rise

Waistband: 8cm flat bonded

Fabric: Front: PWX 70D. 72% Nylon, 28% Lycra
Back: PWX 160D. 65% Nylon, 35% Lycra
(Power, Weight, Flexibility)

Motion

Engineered from flexible and lightweight fabrics, the Motion range is designed for the toughest of training sessions. With apparel featuring breathable ventilation zones to keep you dry, and compression made from 2XU's proprietary PWX fabric for muscle support, you'll be a step above the competition.

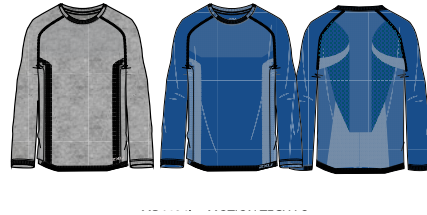

MR6486a
Motion Tech
Long Sleeve

Garment Features:

1. Raglan long sleeve crew
2. Flexible and lightweight moisture-wicking fabric
3. Engineered breathable panelling
4. Longer length for freedom of movement and coverage
5. Ribbed cuffs, hem and neck opening

Best For: Mild Weather
Colours: GRM/GRM, SAP/ECH
Size Range: XS, S, M, L, XL, XXL
Fabric: TBA: Nylon, Polyester, Spandex Blend

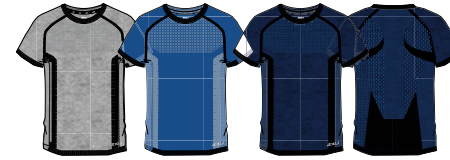

MR6487a
Motion
Tech Tee

Garment Features:

1. Raglan short sleeve
2. Flexible and lightweight moisture-wicking fabric
3. Engineered breathable panelling
4. Longer length for freedom of movement and coverage
5. Ribbed cuffs, hem and neck opening

Best For: Mild Weather, Hot Weather
Colours: GRM/GRM, NVM/NVM, SAP/ECH
Size Range: XS, S, M, L, XL, XXL
Fabric: TBA: Nylon, Polyester, Spandex Blend

Flexible

A longer length, relaxed neckline and forward shoulder seam, provide freedom of movement and coverage when bending and stretching.

Stay Dry

Moisture-wicking fabric that is quick to dry keeps you comfortable throughout the toughest training sessions.

Built To Last

Durable fabric and construction resists pilling and abrasion.



MR6477a
Motion Colour
Block Tee

Garment Features:

1. Raglan short sleeve
2. Durable moisture-wicking fabric
3. Relaxed fit and longer length
4. Bonded tape detail
5. Silicon logo patch

Best For: Mild Weather,
Hot Weather
Colours: AME/BLK, ALP/BLK
Size Range: XS, S, M, L, XL, XXL
Fabric: Solid colours: 87% Polyester
13% Spandex
Marle colours: 88% Polyester
12% Spandex



MR6475a
Motion
Tee

Garment Features:

1. Hybrid short sleeve
2. Durable moisture-wicking fabric
3. Underarm gusset
4. Relaxed fit and longer length
5. Bonded trim and logo detailing

Best For: Mild Weather,
Hot Weather
Colours: BLK/CRF, AME/BLK
Size Range: XS, S, M, L, XL, XXL
Fabric: Solid colours: 87% Polyester
13% Spandex
Marle colours: 88% Polyester
12% Spandex



MR6476a
Motion
Tank

Garment Features:

1. Tank
2. Durable moisture-wicking fabric
3. Forward shoulder seam
4. Relaxed fit and longer length
5. Bonded trim and logo detailing

Best For: Hot Weather
Colours: BLK/CRF, AME/BLK, ALP/BLK
Size Range: XS, S, M, L, XL, XXL
Fabric: Solid colours: 87% Polyester
13% Spandex
Marle colours: 88% Polyester
12% Spandex



MR6479b
Motion
8" Shorts

Lightweight & Flexible

Lightweight 4-way stretch woven fabric has a bonded hem with side splits to provide freedom of movement when bending and stretching.

Essential Storage

Front side pockets and a zip media pocket provide secure storage of your phone, cards or keys during any physical activity.

Total Comfort

Elastic waistband with internal drawcord provides a secure fit during high-paced activity whilst a sphere back texture on the woven fabric prevents cling.

Garment Features:

1. 8" inseam short
2. Lightweight 4-way stretch woven
3. Elastic waistband with internal drawcord
4. Contrast bonded side panels
5. Front side pockets
6. Zip pocket on right side
7. Bonded hem with side splits

Best For: Hot Weather

Colours: BLK/BLK, TRB/BLK, MDN/AME

Size Range: XS, S, M, L, XL, XXL

Fabric: 88% Polyester 12% Spandex



MR6478b
Motion
5" Shorts

Lightweight & Flexible

Lightweight 4-way stretch woven fabric has a bonded hem with side splits to provide freedom of movement when bending and stretching.

Essential Storage

Front side pockets and a zip media pocket provide secure storage of your phone, cards or keys during any physical activity.

Total Comfort

Elastic waistband with internal drawcord provides a secure fit during high-paced activity whilst a sphere back texture on the woven fabric prevents cling.

Garment Features:

1. 5" inseam short
2. Lightweight 4-way stretch woven
3. Elastic waistband with internal drawcord
4. Contrast bonded side panels
5. Front side pockets
6. Zip pocket on right side
7. Bonded hem with side splits

Best For: Hot Weather

Colours: BLK/BLK, TRB/BLK, MDN/AME

Size Range: XS, S, M, L, XL, XXL

Fabric: 88% Polyester 12% Spandex



MA6489b
Motion Comp
Tights

Garment Features:

1. Full length compression tight
2. PWX highly powerful, lightweight and flexible compression fabric
3. Graduated compression for improved circulation
4. Side pocket for phone, cards and keys
5. Flat jacquard elastic waistband for easy layering
6. Mesh gusset for improved breathability
7. Signature X logo on calf
8. Flatlock seams to reduce chafe

Best For: Mild Weather

Colours: BLK/NRO, MDN/NRO, BLK/CRF
Size Range: XXS, XS, S, ST, M, MT, L, LT, XL, XLT, XXL, XXXL
Rise: Regular
Waistband: Jacquard elastic
Fabric: Front: PWX 70D. 72% Nylon, 28% Lycra
 Back: PWX 105D. 65% Nylon, 35% Lycra
 (Power, Weight, Flexibility)



MA6488b
Motion Comp
Shorts

Garment Features:

1. Compression short
2. PWX highly powerful, lightweight and flexible compression fabric
3. Side pocket for phone, cards and keys
4. Flat jacquard waistband for comfort
5. Mesh gusset for improved breathability
6. Signature X logo on thigh
7. Flatlock seams to reduce chafe

Best For: Hot Weather

Colours: BLK/NRO, MDN/NRO, BLK/CRF
Size Range: XXS, XS, S, M, L, XL, XXL, XXXL
Rise: Regular
Waistband: Jacquard elastic
Fabric: Front: PWX 70D. 72% Nylon, 28% Lycra
 Back: PWX 105D. 65% Nylon, 35% Lycra
 (Power, Weight, Flexibility)

Contender

With a natural cotton-feel, this range is made from X-DRY fabric that is durable and quick to dry ensuring unrivaled everyday comfort.



MR6480a
Contender
Windbreaker

Wind Protection

With an adjustable 3 piece hood, the durable lightweight outer layer of this jacket keeps the wind at bay without feeling heavy.

Breathability

Back vent with power mesh lining to enhance breathability and ventilation.

Essential Storage

Front zip hand pockets for secure storage of your phone, cards or keys.

Garment Features:

1. Full zip jacket
2. Lightweight wind-resistant shell
3. Adjustable 3 piece hood
4. Back vent with power mesh lining
5. Front zip pockets
6. Silicon logo patch

Best For: Cold Weather
Mild Weather
Colours: TRB/BLK
Size Range: XS, S, M, L, XL, XXL
Fabric: Main: 100% Polyester
Lining: 80% Polyester
20% Spandex
Rib Trim: 96% Cotton
4% Spandex



MR6490a
Contender Colour
Block Crew

Garment Features:

1. Set-in long sleeve crew
2. Soft loopback fleece
3. 2XU graphic prints on front and back
4. Ribbed neckband, cuffs and hem

Best For: Cold Weather
Colours: SAP/LLT
Size Range: XS, S, M, L, XL, XXL
Fabric: Main: 70% Cotton 30% Polyester
Rib Trim: 96% Cotton 4% Spandex



MR6481a
Contender
Crew

Garment Features:

1. Set-in long sleeve crew
2. Soft loopback fleece
3. Silicon logo patch on chest
4. Ribbed neckband, cuffs and hem

Best For: Cold Weather
Colours: OAT/BLK
Size Range: XS, S, M, L, XL, XXL
Fabric: Main: 70% Cotton 30% Polyester
Rib Trim: 96% Cotton 4% Spandex

Stay Dry

Natural cotton feel X-DRY fabric is four times faster to dry than cotton and highly durable to outlast the toughest of gym sessions.

Total Comfort

A relaxed neckline, forward shoulder seams and longer length, provide freedom of movement and coverage when bending and stretching.



MR6483a
Contender
Tee

Garment Features:

1. Set in short sleeve with forward shoulder seams
2. Natural cotton hand-feel X-DRY fabric
3. Relaxed fit and longer length
4. Embroidery 2XU front chest logo

Best For: Mild Weather,
Hot Weather
Colours: BLK/BLK, WHT/WHT, RUS/RUS,
WHT/SAP
Size Range: XS, S, M, L, XL, XXL
Fabric: X-Dry 80% Polyester 15% Cotton
5% Spandex



MR6482a
Contender
Tank

Garment Features:

1. Tank
2. Natural cotton hand-feel X-DRY fabric
3. Relaxed fit and longer length
4. Silicon logo patch

Best For: Hot Weather
Colours: OAT/BLK, RUS/BLK, WHT/SAP
Size Range: XS, S, M, L, XL, XXL
Fabric: X-Dry 80% Polyester 15% Cotton
5% Spandex



No Distraction

With a unique elastic free design with minimal seams, the No Distraction range sculpts and provides enhanced support without bulk so you can tackle your workout with confidence.



WR6455a
No Distraction Crop

Medium Impact Support

Medium impact support with removable foam cups, a soft v-shaped front and u-shaped back and adjustable bonded hook and eye closure.

Fabric Support System

Leveraging the learnings of MCS technology, silicon bonding and patented 3D extrusion printing change the structure of the soft and stretchy fabric, providing luxurious flat bonded finish, support and chafe free seamless design.

Quick-Drying

Moisture-wicking fabric keeps you dry, comfortable and focused throughout the toughest gym, spin or HIIT sessions.

Garment Features:

1. Medium impact support crop
2. Removable foam cups
3. Soft V-shaped front
4. U-shaped back
5. Luxurious flat bonded finish
6. 3D extrusion print detailing
7. Adjustable hook and eye closure

Best For:	Cold Weather, Mild Weather, Hot Weather
Colours:	CBY/RST
Size Range:	XXS, XS, S, M, L, XL
Fabric:	PWX 105D, 65% Nylon 35% Lycra (Power, Weight, Flexibility)



WA6456b
No Distraction Hi-Rise Compression Tights

Minimal Seaming

No side seam construction ensures an uninterrupted smooth body sculpting fit.

Firm Muscle Support

Lightweight yet powerful PWX fabric reduces muscle movement and damage whilst graduated compression boosts blood flow to muscles, improving performance, lowering risk of injury and speeding up recovery.

Hi-Rise Waistband

Extra high figure flattering and secure waistband with a luxurious flat bonded finish and 3D extrusion print detailing provides supportive coverage and shaping you'll want to show off.

Total Comfort

High quality, durable, moisture-wicking yarns outlast the competition to provide squat proof coverage and keep the skin cool and dry.

Garment Features:

1. Full length compression tight
2. PWX highly powerful, lightweight and flexible compression fabric
3. Graduated compression for improved circulation
4. Hi-Rise figure flattering, slimming and secure fit waistband
5. Body sculpting no side seam construction
6. Luxurious flat bonded finish
7. 3D extrusion print detailing
8. Flatlock seams to reduce chafe

Best For:	Mild Weather
Colours:	CBY/RST
Size Range:	XXS, XS, XST, S, ST, M, MT, L, LT, XL, XXL
Rise:	Hi-Rise
Waistband:	12cm flat bonded
Fabric:	PWX 105D 65% Nylon 35% Lycra (Power, Weight, Flexibility)

Motion

Engineered from flexible and lightweight fabrics, the Motion range is designed for the toughest of training sessions. With apparel featuring breathable ventilation zones to keep you dry, and compression made from 2XU's proprietary PWX fabric for muscle support, you'll be a step above the competition.



WR6450a
Motion Tech
Long Sleeve

Flexible & Lightweight

Engineered from lightweight yarns, the Motion range provides freedom of movement and coverage when bending and stretching.

Stay Dry

Moisture-wicking fabric with engineered breathable ventilation zones, keeps you dry throughout the toughest training sessions.

Built To Last

Durable fabric and construction resists pilling and abrasion.

Garment Features:

1. Raglan long sleeve crew
2. Flexible and lightweight moisture-wicking fabric
3. Engineered breathable panelling
4. Longer length for freedom of movement and coverage
5. Ribbed cuffs, hem and neck opening

Best For: Mild Weather

Colours: GRM/GRM, SHE/RST
Size Range: XXS, XS, S, M, L, XL
Fabric: TBA: Nylon, Polyester, Spandex Blend



WR6451a
Motion Tech
Singlet

Garment Features:

1. Racerback singlet
2. Flexible and lightweight moisture-wicking fabric
3. Engineered breathable panelling
4. Longer length for freedom of movement and coverage

Best For: Hot Weather

Colours: GRM/GRM, SHE/RST
Size Range: XXS, XS, S, M, L, XL
Fabric: TBA: Nylon, Polyester, Spandex Blend



WR6471a
Motion
Tech Bra

Total Comfort

Durable and flexible engineered fabric with removable foam cups, thin multi-way adjustable straps, soft ribbed underbust band and adjustable hook and eye closure provide comfort without compromise.

Garment Features:

1. Engineered bra
2. Built in moulded foam cups
3. Soft ribbed underbust band
4. Thin multi-way adjustable straps
5. Hook and eye closure

Best For: Cold Weather, Mild Weather, Hot Weather

Colours: BLK/TRB, GRM/WHT
Size Range: XXS, XS, S, M, L, XL
Fabric: Main: TBA Nylon, Polyester, Spandex Blend
 Mesh Lining: 75% Nylon 25% Elastane



WR6472b
Motion
Tech Tights

Total Comfort

Durable and flexible engineered fabric with a figure slimming high ribbed waistband and jacquard print for breathability so you can stay comfortable all day.

Garment Features:

1. Full length engineered tight
2. Durable and flexible engineered
3. Hi-Rise ribbed figure slimming waistband
4. Jacquard print

Best For: Cold Weather, Mild Weather

Colours: BLK/TRB, GRM/WHT
Size Range: XXS, XS, S, M, L, XL
Fabric: Main: TBA Nylon, Polyester, Spandex Blend
 Mesh Lining: 75% Nylon 25% Elastane



WR6415a
Motion
Mesh Tee

Stay Dry

Super lightweight moisture-wicking fabric with breathable mesh paneling, keeps you dry throughout the toughest training sessions.

Total Comfort

Longer length provides freedom of movement and coverage when bending and stretching.

Built To Last

Durable fabric and construction resists pilling and abrasion.

No Smell

Yarn level anti-odour technology keeps you fresher for longer between washes, reducing your environmental footprint.

Garment Features:

1. Set in short sleeve tee
2. Durable moisture-wicking fabric
3. Breathable mesh panelling
4. Relaxed fit and longer length
5. Yarn level anti-odour technology

Best For: Mild Weather, Hot Weather
Colours: BLK/BLK, CBY/RST, BOT/MTN
Size Range: XXS, XS, S, M, L, XL
Fabric: Main: 76% Nylon 24% Elastane
 Mesh: 80% Nylon 20% Elastane

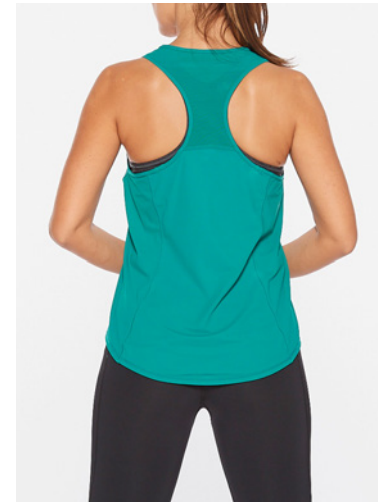

WR6416a
Motion
Mesh Tank

Garment Features:

1. Racerback tank
2. Durable moisture-wicking fabric
3. Breathable mesh panelling
4. Relaxed fit and longer length
5. Yarn level anti-odour technology

Best For: Hot Weather
Colours: BLK/BLK, CBY/RST, BOT/MTN
Size Range: XXS, XS, S, M, L, XL
Fabric: Main: 76% Nylon 24% Elastane
 Mesh: 80% Nylon 20% Elastane



WR6459a
Motion Racerback Crop

Designed to prevent bounce and keep you comfortable, the Motion Racerback Crop is ideal for short-distance running, spin classes and your next training session at the gym.

MEDIUM IMPACT SUPPORT

Medium impact support with removable foam cups and key hole back with adjustable hook and eye closure.

STAY DRY

Moisture-wicking fabric with power mesh back panel and centre-front splicing increases breathability and keeps you dry throughout the toughest workouts.

TOTAL COMFORT

Soft underband elastic with racerback design allows full range of motion.

Garment Features:

1. Medium impact support crop
2. Removable foam cups
3. Durable moisture-wicking fabric
4. Intricate flocked detailing
5. Racerback
6. Soft underband elastic
7. Key hole back with adjustable hook and eye closureing

Best For: Cold Weather, Mild Weather, Hot Weather
Colours: BLK/BOT, CBD/WHT, HRR/WHT, BLK/WHT, CBN/BLK
Size Range: XXS, XS, S, M, L, XL
Fabric: Main: 72% Nylon 28% Lycra
 Mesh: 80% Nylon 20% Elastane

Motion Compression

The Motion Compression range sculpts for a secure fit, keeping you covered whilst you move without getting in your way.

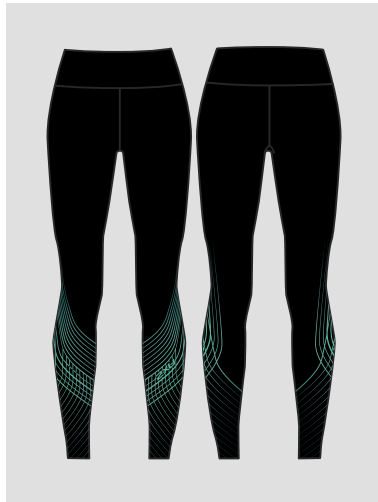

WA6460b
Motion Texture
Mid-Rise Comp Tights

Garment Features:

1. Full length compression tight
2. PWX highly powerful, lightweight and flexible compression fabric
3. Graduated compression for improved circulation
4. Mid-Rise power mesh waistband for body sculpting secure fit
5. Intricate flocked detailing
6. Flatlock seams to reduce chafe

Best For:	Mild Weather
Colours:	BLK/BOT
Size Range:	XXS, XS, XST, S, ST, M, MT, L, LT, XL, XXL
Rise:	Mid-Rise
Waistband:	8cm power mesh
Fabric:	Front: PWX 70D. 72% Nylon, 28% Lycra Back: PWX 160D. 65% Nylon, 35% Lycra (Power, Weight, Flexibility)

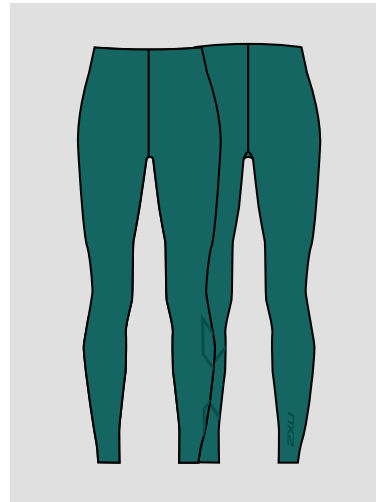

WA6465b
Motion Sculpt Hi-Rise
Comp Tights

Garment Features:

1. Full length compression tight
2. PWX highly powerful, lightweight and flexible compression fabric
3. Graduated compression for improved circulation
4. Hi-Rise figure flattering, slimming and secure fit waistband
5. Luxurious flat bonded finish
6. Body sculpting no side seam construction
7. Signature tonal X logo on calf
8. Flatlock seams to reduce chafe

Best For:	Mild Weather
Colours:	BOT/MTN
Size Range:	XXS, XS, XST, S, ST, M, MT, L, LT, XL, XXL
Rise:	Hi-Rise
Waistband:	12cm flat bonded
Fabric:	PWX 160D. 72% Nylon 28% Lycra (Power, Weight, Flexibility)



WA6357b
Motion Print Hi-Rise
Comp Tights

Garment Features:

1. Full length compression tight
2. PWX highly powerful, lightweight and flexible compression fabric
3. Hi-Rise figure flattering, slimming and secure fit waistband
4. Graduated compression for improved circulation
5. Signature X logo on calf
6. Flatlock seams to reduce chafe

Best For:	Mild Weather
Colours:	MDN/WHT, CBN/BLK
Size Range:	XXS, XS, XST, S, ST, M, MT, L, LT, XL, XXL
Rise:	Hi-Rise
Waistband:	12cm power mesh
Fabric:	Upper Front: PWX 70D. 72% Nylon, 28% Lycra Upper Back: PWX 160D. 65% Nylon, 35% Lycra Lower - PWX 105D. 65% Nylon, 35% Lycra (Power, Weight, Flexibility)



WA5380b
Motion Hi-Rise
Comp Tights

Garment Features:

1. Full length compression tight
2. PWX highly powerful, lightweight and flexible compression fabric
3. Hi-Rise figure flattering, slimming and secure fit waistband
4. Graduated compression for improved circulation
5. Signature X logo on calf
6. Flatlock seams to reduce chafe

Best For:	Mild Weather
Colours:	BLK/NRO, BLK/SXL
Size Range:	XXS, XS, XST, S, ST, M, MT, L, LT, XL, XXL
Rise:	Hi-Rise
Waistband:	12cm power mesh
Fabric:	Upper Front: PWX 70D. 72% Nylon, 28% Lycra Upper Back: PWX 160D. 65% Nylon, 35% Lycra Lower - PWX 105D. 65% Nylon, 35% Lycra (Power, Weight, Flexibility)



WA5378b
Motion Print Mid-Rise
Comp Tights

Garment Features:

1. Full length compression tight
2. PWX highly powerful, lightweight and flexible compression fabric
3. Mid-Rise power mesh waistband for body sculpting secure fit
4. Graduated compression for improved circulation
5. Signature X logo on calf
6. Flatlock seams to reduce chafe

Best For:	Mild Weather
Colours:	CBN/BLK
Size Range:	XXS, XS, XST, S, ST, M, MT, L, LT, XL, XXL
Rise:	Mid-Rise
Waistband:	8cm power mesh
Fabric:	Front: PWX 70D. 72% Nylon, 28% Lycra Back: PWX 160D. 65% Nylon, 35% Lycra (Power, Weight, Flexibility)



WA2864b
Motion Mid-Rise
Comp Tights

Garment Features:

1. Full length compression tight
2. PWX highly powerful, lightweight and flexible compression fabric
3. Mid-Rise power mesh waistband for body sculpting secure fit
4. Graduated compression for improved circulation
5. Signature dotted X logo on thigh and calf
6. Flatlock seams to reduce chafe

Best For:	Mild Weather
Colours:	BLK/CBY, BLK/CBD, BLK/DRF, BLK/DBK
Size Range:	XXS, XS, XST, S, ST, M, MT, L, LT, XL, XXL
Rise:	Mid-Rise
Waistband:	8cm power mesh
Fabric:	Front: PWX 70D. 72% Nylon, 28% Lycra Back: PWX 160D. 65% Nylon, 35% Lycra (Power, Weight, Flexibility)



WA3516b
Motion Mid-Rise
Comp 7/8 Tights

Garment Features:

1. 7/8 compression tight
2. PWX highly powerful, lightweight and flexible compression fabric
3. Mid-Rise power mesh waistband for body sculpting secure fit
4. Graduated compression for improved circulation
5. Signature dotted reflective X logo on thigh and calf
6. Flatlock seams to reduce chafe

Best For:	Mild Weather
Colours:	BLK/DRF, BLK/DBK
Size Range:	XXS, XS, XST, S, ST, M, MT, L, LT, XL, XXL
Rise:	Mid-Rise
Waistband:	8cm power mesh
Fabric:	Front: PWX 70D. 72% Nylon, 28% Lycra Back: PWX 160D. 65% Nylon, 35% Lycra (Power, Weight, Flexibility)



WA3027b
Motion Mid-Rise
Comp Short

Garment Features:

1. Compression short
2. PWX highly powerful, lightweight and flexible compression fabric
3. Mid-Rise power mesh waistband for body sculpting secure fit
4. Signature dotted X logo on thigh
5. Flatlock seams to reduce chafe

Best For:	Hot Weather
Colours:	BLK/DBK
Size Range:	XXS, XS, XST, S, ST, M, MT, L, LT, XL, XXL
Rise:	Mid-Rise
Waistband:	8cm power mesh
Fabric:	Front: PWX 70D. 72% Nylon, 28% Lycra Back: PWX 160D. 65% Nylon, 35% Lycra (Power, Weight, Flexibility)

Form

Designed for everyday comfort, the Form collection features soft, breathable fabrics that keep you supported all day long. Buttery, ultra-matte SLX fabric provides mild compression for a flattering fit, while cotton-feel X-DRY fabric keeps you dry during the toughest of training sessions.



WR6457a
Form
Jacket

Stay Warm

A stand up collar and cuffs with thumbholes that flip over to become mittens keep your neck and hands warm.

Total Comfort

Soft durable high-stretch fabric provides complete freedom of movement and coverage whilst strategically placed mesh panels let cool air in when you start to warm up.

Essential Storage

Invisible zip front pockets provide a secure location to keep your cards or keys while on the move.

Garment Features:

1. Full zip jacket
2. Soft durable high-stretch fabric
3. Stand up collar
4. Cuffs with thumbholes and flip over mittens
5. Strategically placed mesh panels
6. Invisible zip front pockets
7. Scooped back hem

Best For: Cold Weather, Mild Weather
Colours: BLK/BLK
Size Range: XXS, XS, S, M, L, XL
Fabric: 62% Polyamide 38% Elastane



WR6458a
Form Crop
Crew

Garment Features:

1. Set-in long sleeve crew
2. Soft loopback fleece
3. Cropped length
4. Embroidered logo patch on chest
5. Ribbed neckband, cuffs and hem

Best For: Cold Weather
Colours: OAT/OAT, BLK/HRR
Size Range: XXS, XS, S, M, L, XL
Fabric: Main: 70% Cotton 30% Polyester
 Rib Trim: 96% Cotton 4% Spandex



WR6466a
Form Crop
Tee

Garment Features:

1. Set-in long sleeve crew
2. Soft loopback fleece
3. Cropped length
4. Embroidered logo patch on chest
5. Ribbed neckband, cuffs and hem

Best For: Mild Weather,
Hot Weather
Colours: WHT/BLK, OAT/WHT, RST/SHE
Size Range: XXS, XS, S, M, L, XL
Fabric: X-Dry 80% Polyester 15% Cotton
5% Spandex



WR6452a
Form Singlet

Garment Features:

1. Strappy Y-back singlet
2. Natural cotton hand-feel X-DRY fabric
3. Square neckline
4. Scooped back hem
5. High gloss Two Times You print on chest

Best For: Hot Weather
Colours: BLK/BLK, ALP/BLK
Size Range: XXS, XS, S, M, L, XL
Fabric: X-Dry 80% Polyester 15% Cotton 5% Spandex



WR6470a
Form Tank

Garment Features:

1. Tank
2. Natural cotton hand-feel X-DRY fabric
3. Relaxed neckline
4. Low armholes
5. Scooped back hem
6. Embroidery 2XU front chest logo

Best For: Hot Weather
Colours: WHT/BLK, GRM/WHT
Size Range: XXS, XS, S, M, L, XL
Fabric: X-Dry 80% Polyester 15% Cotton 5% Spandex



WR6469a
Form Crop Tank

Garment Features:

1. Crop tank
2. Natural cotton hand-feel X-DRY fabric
3. High neckline
4. Low armholes
5. 2XU printed chest graphic

Best For: Hot Weather
Colours: WHT/WHT, CBD/CBD
Size Range: XXS, XS, S, M, L, XL
Fabric: X-Dry 80% Polyester 15% Cotton 5% Spandex



WR6467a
Form Strappy Crop

Garment Features:

1. Low impact support
2. Full front coverage
3. Soft underband elastic
4. Criss cross back strap design

Best For: Cold Weather, Mild Weather, Hot Weather
Colours: WHT/BLK, INR/BLK
Size Range: XXS, XS, S, M, L, XL
Fabric: 62% Polyamide 38% Elastane





WA6473b
Form Block Hi-Rise Comp Tights

Garment Features:

1. Full length compression tight
2. Ultra-matte, anti-pill SLX double knit fabric
3. Hi-Rise figure flattering, slimming and secure fit waistband
4. Graduated compression for improved circulation
5. Large side pocket for phone and essentials
6. Colour block lower leg and side stripe
7. 3D 2XU logo on lower leg
8. Flatlock seams to reduce chafe

Best For: Mild Weather

Colours: MDN/WHT, BLK/HRR
Size Range: XXS, XS, XST, S, ST, M, MT, L, LT, XL, XXL
Rise: Hi-Rise
Waistband: 12cm power mesh
Fabric: SLX (Sculpt, Luxe, FleXibility)
 62% Polyamide 38% Elastane



WA6468b
Form Spliced Hi-Rise Comp Tights

Garment Features:

1. Full length compression tight
2. Ultra-matte, anti-pill SLX double knit fabric
3. Hi-Rise figure flattering, slimming and secure fit waistband
4. Graduated compression for improved circulation
5. Side stripe with spliced print panel
6. Bonded overlay detailing
7. Flatlock seams to reduce chafe

Best For: Mild Weather

Colours: NR/RST
Size Range: XXS, XS, XST, S, ST, M, MT, L, LT, XL, XXL
Rise: Hi-Rise
Waistband: 12cm power mesh
Fabric: SLX (Sculpt, Luxe, FleXibility)
 62% Polyamide 38% Elastane



WA6453b
Form Lineup Hi-Rise Comp Tights

Garment Features:

1. Full length compression tight
2. Ultra-matte, anti-pill SLX double knit fabric
3. Hi-Rise figure flattering, slimming and secure fit waistband
4. Graduated compression for improved circulation
5. Large side pocket for phone and essentials
6. Side stripe with high gloss Two Times You print
7. Flatlock seams to reduce chafe

Best For: Mild Weather

Colours: BLK/BLK, ALP/BLK
Size Range: XXS, XS, XST, S, ST, M, MT, L, LT, XL, XXL
Rise: Hi-Rise
Waistband: 12cm power mesh
Fabric: SLX (Sculpt, Luxe, FleXibility)
 62% Polyamide 38% Elastane



WA6110b
Form Stash Hi-Rise Comp Tights

Garment Features:

1. Full length compression tight
2. Ultra-matte, anti-pill SLX double knit fabric
3. Hi-Rise figure flattering, slimming and secure fit waistband
4. Graduated compression for improved circulation
5. Large side pocket for phone and essentials
6. 3D 2XU logo on lower leg
7. Flatlock seams to reduce chafe

Best For: Mild Weather

Colours: BLK/WHT
Size Range: XXS, XS, XST, S, ST, M, MT, L, LT, XL, XXL
Rise: Hi-Rise
Waistband: 12cm power mesh
Fabric: SLX (Sculpt, Luxe, FleXibility)
 62% Polyamide 38% Elastane



WA5382b
Form Hi-Rise
Comp Tights

Garment Features:

1. Full length compression tight
2. Ultra-matte, anti-pill SLX double knit fabric
3. Hi-Rise figure flattering, slimming and secure fit waistband
4. Graduated compression for improved circulation
5. Flatlock seams to reduce chafe

Best For: Mild Weather
Colours: BLK/BLK
Size Range: XXS, XS, XST, S, ST, M, MT, L, LT, XL, XXL
Rise: Hi-Rise
Waistband: 12cm power mesh
Fabric: SLX (Sculpt, Luxe, FleXibility)
62% Polyamide 38% Elastane



WA5383b
Form Hi-Rise
Comp 7/8 Tights

Garment Features:

1. 7/8 compression tight
2. Ultra-matte, anti-pill Interlock double knit fabric
3. Hi-Rise figure flattering, slimming and secure fit waistband
4. Flatlock seams to reduce chafe
5. Antibacterial and anti-odour technology

Best For: Mild Weather
Colours: BLK/BLK
Size Range: XXS, XS, XST, S, ST, M, MT, L, LT, XL, XXL
Rise: Hi-Rise
Waistband: 12cm power mesh
Fabric: SLX (Sculpt, Luxe, FleXibility)
62% Polyamide 38% Elastane



WA6454b
Form Lineup Hi-Rise
Bike Shorts

Garment Features:

1. Compression bike short
2. Ultra-matte, anti-pill SLX double knit fabric
3. Hi-Rise figure flattering, slimming and secure fit waistband
4. Large side pocket for phone and essentials
5. Panels on side with high gloss Two Times You print
6. Flatlock seams to reduce chafe

Best For: Hot Weather
Colours: BLK/BLK
Size Range: XXS, XS, XST, S, ST, M, MT, L, LT, XL, XXL
Rise: Hi-Rise
Waistband: 12cm power mesh
Fabric: SLX (Sculpt, Luxe, FleXibility)
62% Polyamide 38% Elastane



WA6161b
Form Stash Hi-Rise
Bike Shorts

Garment Features:

1. Compression bike short
2. Ultra-matte, anti-pill SLX double knit fabric
3. Hi-Rise figure flattering, slimming and secure fit waistband
4. Large side pocket for phone and essentials
5. 3D 2XU logo on thigh
6. Flatlock seams to reduce chafe

Best For: Hot Weather
Colours: BLK/BLK
Size Range: XXS, XS, S, M, L, XL, XXL
Rise: Hi-Rise
Waistband: 12cm power mesh
Fabric: SLX (Sculpt, Luxe, FleXibility)
62% Polyamide 38% Elastane



WA5387b
Form Print Mid-Rise
Comp Tights

Garment Features:

1. Full length compression tight
2. Ultra-matte, anti-pill SLX double knit fabric
3. Graduated compression for improved circulation
4. Mid-Rise power mesh waistband for body sculpting secure fit
5. All over merged animal print
6. Flatlock seams to reduce chafe

Best For:	Mild Weather
Colours:	INR/BLK
Size Range:	XXS, XS, XST, S, ST, M, MT, L, LT, XL, XXL
Rise:	Mid-Rise
Waistband:	8cm power mesh
Fabric:	SLX (Sculpt, Luxe, FleXibility) 62% Polyamide 38% Elastane



WA6363b
Form Mid-Rise
Comp Tights

Garment Features:

1. Full length compression tight
2. Ultra-matte, anti-pill SLX double knit fabric
3. Graduated compression for improved circulation
4. Mid-Rise power mesh waistband for body sculpting secure fit
5. Flatlock seams to reduce chafe

Best For:	Mild Weather
Colours:	BLK/SIL
Size Range:	XXS, XS, XST, S, ST, M, MT, L, LT, XL, XXL
Rise:	Mid-Rise
Waistband:	8cm power mesh
Fabric:	SLX (Sculpt, Luxe, FleXibility) 62% Polyamide 38% Elastane



WA6364b
Form Mid-Rise Comp
7/8 Tights

Garment Features:

1. 7/8 compression tight
2. Ultra-matte, anti-pill SLX double knit fabric
3. Mid-Rise power mesh waistband for body sculpting secure fit
4. Flatlock seams to reduce chafe

Best For:	Mild Weather
Colours:	BLK/SIL
Size Range:	XXS, XS, XST, S, ST, M, MT, L, LT, XL, XXL
Rise:	Mid-Rise
Waistband:	8cm power mesh
Fabric:	SLX (Sculpt, Luxe, FleXibility) 62% Polyamide 38% Elastane



WA5386b
Form Mid-Rise Comp
3/4 Tights

Garment Features:

1. 3/4 compression tight
2. Ultra-matte, anti-pill SLX double knit fabric
3. Mid-Rise power mesh waistband for body sculpting secure fit
4. Flatlock seams to reduce chafe

Best For:	Mild Weather, Hot Weather
Colours:	BLK/SIL
Size Range:	XXS, XS, XST, S, ST, M, MT, L, LT, XL, XXL
Rise:	Mid-Rise
Waistband:	8cm power mesh
Fabric:	SLX (Sculpt, Luxe, FleXibility) 62% Polyamide 38% Elastane



WA4482b
Form Mid-Rise Comp
4" Shorts

Garment Features:

1. 4" compression short
2. Ultra-matte, anti-pill SLX double knit fabric
3. Mid-Rise power mesh waistband for body sculpting secure fit
4. Flatlock seams to reduce chafe

Best For:	Hot Weather
Colours:	BLK/SIL
Size Range:	XXS, XS, S, M, L, XL, XXL
Rise:	Mid-Rise
Waistband:	8cm power mesh
Fabric:	SLX (Sculpt, Luxe, FleXibility) 62% Polyamide 38% Elastane

Breeze

Stay cool when your workout heats up. The Breeze collection keeps you cool and supported during the most intense workouts.



WR6448a
Breeze
Mesh Crop

Medium Impact Support

Medium impact support with removable foam cups, higher neckline and a wide strapped racerback design to help hold you in.

Stay Cool

Striped mesh panelling through back lets air flow freely to keep you cool.

Total Comfort

High quality, durable, moisture-wicking yarns outlast the competition to provide 360 degree flexibility and keep the skin dry.

Garment Features:

1. Medium impact support crop
2. Removable foam cups
3. Racerback striped mesh panelling
4. Wide straps
5. Clean cut bonded finishing

Best For: Hot Weather, Cold Weather
Colours: BLK/BLK
Size Range: XXS, XS, S, M, L, XL
Fabric: Main: 72% Nylon 28% Elastane
 Mesh: 80% Nylon 20% Elastane



WR6447b
Breeze Mesh
Hi-Rise Tights

Stay Cool

Striped mesh waistband and mesh splicing at the back of legs lets air flow freely to keep you cool when your workout heats up.

Hi-Rise Waistband

Extra high figure flattering flat bonded secure waistband with internal pocket provides supportive coverage and shaping you'll want to show off.

Total Comfort

High quality, durable, moisture-wicking yarns outlast the competition to provide squat proof coverage and keep the skin cool and dry.

Garment Features:

1. Full length compression tight
2. PWX highly powerful, lightweight and flexible compression fabric
3. Hi-Rise figure flattering flat bonded secure waistband
4. Striped mesh waistband
5. Bonded pocket on internal waistband
6. Mesh splicing at back of legs
7. Flatlock seams to reduce chafe
8. Clean cut bonded finishing

Best For: Mild Weather, Hot Weather
Colours: BLK/BLK
Size Range: XXS, XS, XST, S, ST, M, MT, L, LT, XL, XXL
Rise: Hi-Rise
Waistband: 12cm flat bonded
Fabric: Front: PWX 70D. 72% Nylon, 28% Lycra
 Back: PWX 160D. 65% Nylon, 35% Lycra
 Mesh: 80% Nylon, 20% Elastane (Power, Weight, Flexibility)

Engineered

Durable and supportive, the Engineered range provides figure-flattering comfort without compromise.

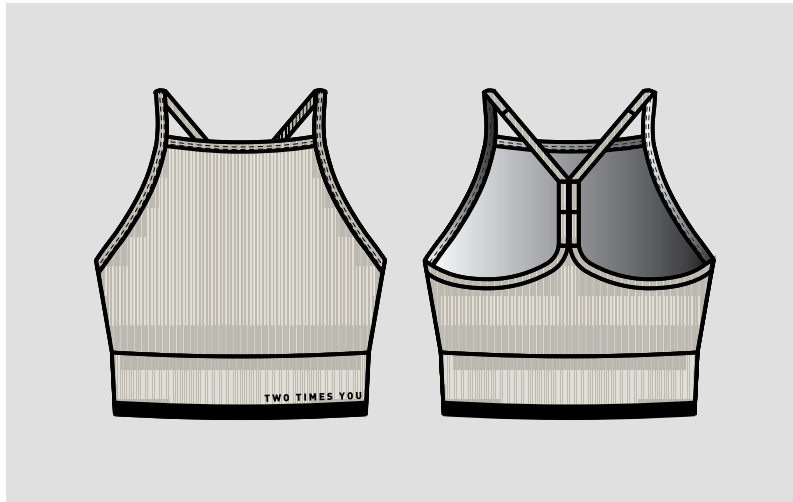

WR6462a
Engineered Longline Crop

Total Comfort

Durable and flexible engineered fabric with removable foam cups, thin multi-way adjustable straps, soft ribbed underbust band and adjustable hook and eye closure provide comfort without compromise.

Garment Features:

1. Engineered longline crop
2. Ribbed texture
3. Y-back design
4. Contrast hem
5. Two Times You knitted logo

Best For: Cold Weather, Mild Weather, Hot Weather
Colours: OAT/BLK
Size Range: XXS, XS, S, M, L, XL
Fabric: Main: TBA Nylon, Polyester, Spandex Blend
 Mesh Lining: 75% Nylon
 25% Elastane

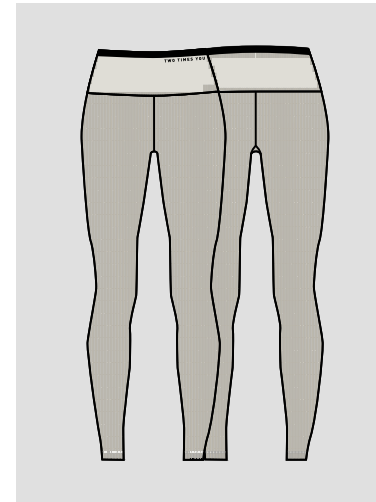

WR6464b
Engineered Tights

Total Comfort

Durable and flexible engineered fabric with a figure slimming high ribbed waistband and jacquard print for breathability so you can stay comfortable all day.

Garment Features:

1. Full length engineered tight
2. Ribbed texture
3. Hi-Rise figure slimming waistband
4. Contrast hem
5. Two Times You knitted logo

Best For: Cold Weather, Mild Weather
Colours: OAT/BLK
Size Range: XXS, XS, S, M, L, XL
Fabric: Main: TBA Nylon, Polyester, Spandex Blend
 Mesh Lining: 75% Nylon
 25% Elastane

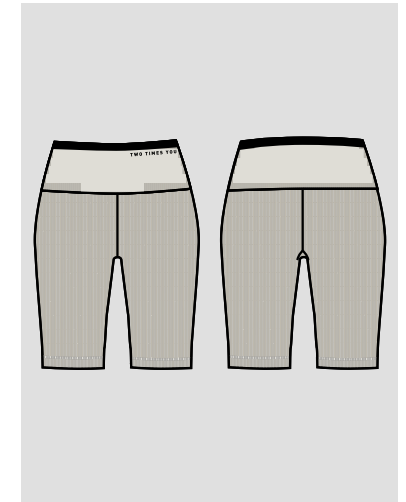

WR6463b
Engineered Shorts

Total Comfort

Durable and flexible engineered fabric with a figure slimming high ribbed waistband and jacquard print for breathability so you can stay comfortable all day.

Garment Features:

1. Engineered short
2. Ribbed texture
3. Hi-Rise figure slimming waistband
4. Contrast hem
5. Two Times You knitted logo

Best For: Mild Weather, Hot Weather
Colours: OAT/BLK
Size Range: XXS, XS, S, M, L, XL
Fabric: Main: TBA Nylon, Polyester, Spandex Blend
 Mesh Lining: 75% Nylon
 25% Elastane

PREFORMO

A woman is running on a track, seen from behind. The image is overlaid with a large, textured, golden-yellow 'BRM' logo. The background is a blurred outdoor setting with a car visible in the distance.

BRM

PERFORM BETTER

In training or in a race we all deep down look at performance. We constantly measure ourselves against personal records, competitors and yesterday. This is our measure, our sign of progress.

RUNNING

GO-TO-MARKET

**WHETHER IT'S A MARATHON, OR A SHORT RECOVERY RUN, RACE-DAY PERFORMANCE IS PARAMOUNT.
LEADING FABRIC TECHNOLOGY CAN PROVIDE AN EDGE OVER THE COMPETITION.**

CONSUMER PROFILE

Relentless in their pursuit of performance, our running consumer seeks the highest quality product for their run. They run on the road, track and trail in the heat and in the cold. They want to feel confident knowing their product won't let them down in any situation.

COLLECTIONS GUIDE

LIGHT SPEED

Versatility for unrivalled run comfort.

IGNITION

Stay warm, dry and protected.

WIND DEFENCE

Beat the elements with confidence.

AERO

Stay cool and on-track for every run everyday.



GOAL Innovation will be at the forefront of our running collections driving us to lead the market and become the go to technical running apparel brand.

NOW Utilize the strength of compression (Recovery and Performance) to grow running consumer base and introduce them to hero products.

MARKETING SUPPORT

- Print Advertising
- Digital Advertising
- Social Media
- Trade Marketing
- Visual Merchandising
- Seeding Packs
- Ambassador Marketing
- Athlete Marketing
- Community and Event Marketing

Ignition

The IGNITION range is designed to protect you from the harsh elements, allowing you to tailor your warmth to your environment and continue those ambitious pursuits with no distractions.



MR6510a / WR6580a
Ignition Insulation Jacket

Garment Features:

1. Full zip jacket
2. Stand collar
3. Stretch knit water-resistant downproof shell
4. Environmentally responsible C6 DWR surface treatment
5. Bonded insulation channels
6. 600 fill-power down insulation
7. Fleece-lined invisible front zip pockets
8. Internal chest zip pocket
9. Reflective front chest graphic and trims

Men:

Best For: Cold Weather, Wet Weather
Colours: BLK/BRF
Size Range: XS, S, M, L, XL, XXL
Fabric: Main: 100% Polyester
 Fill: 90% Down 10% Feather

Women:

Best For: Cold Weather, Wet Weather
Colours: BLK/BRF
Size Range: XXS, XS, S, M, L, XL
Fabric: Main: 100% Polyester
 Fill: 90% Down 10% Feather



MR6511a / WR6525a
Ignition Insulation Vest

Garment Features:

1. Full zip vest
2. Stand collar
3. Stretch knit water-resistant downproof shell
4. Environmentally responsible C6 DWR surface treatment
5. Bonded insulation channels
6. 600 fill-power down insulation
7. Laser cut ventilation down centre back
8. Fleece-lined invisible front zip pockets
9. Internal chest zip pocket
10. Reflective front chest graphic and trims

Men:

Best For: Cold Weather, Wet Weather
Colours: BLK/BRF
Size Range: XS, S, M, L, XL, XXL
Fabric: PWX Thermal (Power, LightWeight, Flexibility)
 Front: 100% Polyester
 Fill: 90% Down, 10% Feather
 Back: 65% Nylon/35% Lycra

Women:

Best For: Cold Weather, Wet Weather
Colours: BLK/BRF
Size Range: XXS, XS, S, M, L, XL
Fabric: PWX 70D Thermal (Power, LightWeight, Flexibility)
 Front: 100% Polyester
 Fill: 90% Down, 10% Feather
 Back: 65% Nylon/35% Lycra





MR6554a / WR6562a
Ignition
1/4 Zip

Stay warm

Recycled double-knit three-dimensional waffle construction creates small air pockets that trap body heat in, while cuffs with thumbholes flip over to become mittens to keep your hands warm.

Quick-Drying

Recycled double-knit three-dimensional waffle construction allows air to flow through the fabric, increasing breathability and speed to dry.

Essential Storage

A zip pocket on the arm offers a bounce-free solution for securing cards or keys while you run.

Be Seen

Reflective logos for greater visibility in low-light conditions.

Garment Features:

1. 1/4 zip long sleeve
2. Stand collar
3. Recycled double-knit waffle construction
4. Arm zip pocket
5. Cuffs with thumbholes and flip over mittens
6. Reflective logos and trims

	Men:	Women:
Best For:	Cold Weather	Cold Weather
Colours:	TRB/BRF, ALP/KRF, MDN/SRF	GRM/SRF, MDN/WRF, PCL/WRF
Size Range:	XS, S, M, L, XL, XXL	XXS, XS, S, M, L, XL
Fabric:	94% Recycled Polyester 6% Spandex	94% Recycled Polyester 6% Spandex

MR6340a / WR6342a
Ignition Base Layer
Long Sleeve

Stay warm

Revolutionary X-HEAT fabric with carbon nano technology warms you up quickly, while ceramic infused yarns maintain a comfortable temperature in cold conditions.

Quick-Drying

With zero static cling, X-HEAT fabric's structure and shape is designed to wick sweat from the skin's surface to keep you dry.

No Smell

X-HEAT fabric has a naturally occurring antibacterial and anti-odour technology keeps you fresher for longer between washes, reducing your environmental footprint.

Garment Features:

1. Long sleeve base layer
2. Ceramic-infused X-HEAT fabric
3. Naturally occurring antibacterial and anti-odour technology

	Men:	Women:
Best For:	Cold Weather	Cold Weather
Colours:	BLM/SRF	BLM/SRF
Size Range:	XS, S, M, L, XL, XXL	XXS, XS, S, M, L, XL
Fabric:	X-HEAT 62% Polyester 33% Rayon 5% Elastane	X-HEAT 62% Polyester 33% Rayon 5% Elastane

Ignition Compression

Cold-weather essentials for every runner, the Ignition Compression range protects you from the elements, keeping you warm and dry on the run.



MA6311b / WA6312b

Wind Defence Compression Tights

Stay Warm

Advanced 20k/20k waterproof stretch membrane panels on upper legs withstand rain and showers while soft brushed PWX Thermal fabric on lower legs create small pockets of air that trap body heat in.

Firm Muscle Support

Powerful, lightweight PWX fabric with circular knit 360-degree stretch, reduces muscle movement and damage whilst maintaining flexibility for ultimate sports performance.

Graduated Compression

Graduated compression boosts blood flow to muscles, improving performance, lowering risk of injury and speeding up recovery.

Quick-Drying

High quality, durable, moisture-wicking yarns outlast the competition and keep the skin cool and dry.

Be Seen

Reflective X logos for greater visibility in low-light conditions.

Men:

Best For:	Cold Weather, Wet Weather
Colours:	BLK/SSR
Size Range:	XXS, XS, S, ST, M, MT, L, LT, XL, XLT, XXL, XXLT, XXXL
Rise:	Regular
Waistband:	3.5cm covered elastic with drawstring
Fabric:	Upper front: Membrane 100% Polyester PWX Thermal 65% Nylon, 35% Lycra (Power, LightWeight, FleXibility)

Garment Features:

1. Full length compression tight
2. Upper leg 20k/20k waterproof membrane
3. Lower leg PWX Thermal highly powerful, lightweight and flexible compression fabric
4. Soft brushed internal construction for warmth
5. Graduated compression for improved blood flow
6. Drawstring waistband for a secure fit
7. Rear zip pocket for secure bounce-free storage
8. Signature reflective X on thigh and calf
9. Flatlock seams to reduce chafe

Women:

Best For:	Cold Weather, Wet Weather
Colours:	BLK/SSR
Size Range:	XXS, XS, XST, S, ST, M, MT, L, LT, XL, XXL
Rise:	Regular
Waistband:	3.5cm covered elastic with drawstring
Fabric:	Upper front: Membrane 100% Polyester PWX 105D Thermal 65% Nylon, 35% Lycra (Power, LightWeight, FleXibility)



MA6552b / WA6352b
Ignition Mid-Rise Compression Tights

Stay Warm

The soft brushed PWX Thermal fabric construction creates small air pockets that trap body heat in.

Firm Muscle Support

Powerful, lightweight PWX fabric with circular knit 360-degree stretch, reduces muscle movement and damage whilst maintaining flexibility for ultimate sports performance.

Graduated Compression

Graduated compression boosts blood flow to muscles, improving performance, lowering risk of injury and speeding up recovery.

Quick-Drying

High quality, durable, moisture-wicking yarns outlast the competition and keep the skin cool and dry.

Men:

Best For:	Cold Weather
Colours:	BLK/NRO
Size Range:	XXS, XS, XST, S, ST, M, MT, L, LT, XL, XXL
Rise:	Mid-Rise
Waistband:	8cm power mesh
Fabric:	PWX 70D Thermal (Power, Weight, Flexibility) 75% Nylon 25% Lycra



MA6404a / WA6405a
Ignition Compression Long Sleeve

Stay Warm

The soft brushed PWX THERMAL fabric construction creates small air pockets that traps body heat in and PWX VENT fabric under arms allow for thermoregulation.

Firm Muscle Support

Lightweight yet powerful PWX Thermal fabric reduces muscle movement whilst compression boosts blood flow to muscles, improving performance, lowering risk of injury and speeding up recovery.

Quick-Drying

High quality, durable, moisture-wicking yarns outlast the competition and keep the skin cool and dry.

Garment Features:

1. Full length compression tight
2. PWX highly powerful, lightweight and flexible compression fabric
3. Soft brushed thermal interior
4. Graduated compression boosts blood flow to muscles
5. Mid-Rise power mesh waistband for body sculpting secure fit
6. Signature tonal X on calf
7. Flatlock seams to reduce chafe

Women:

Best For:	Cold Weather
Colours:	BLK/NRO
Size Range:	XXS, XS, S, ST, M, MT, L, LT, XL, XLT, XXL, XXLT, XXXL
Rise:	Regular
Waistband:	Jacquard elastic
Fabric:	PWX Thermal (Power, Weight, Flexibility) 75% Nylon 25% Lycra

Garment Features:

1. Long sleeve compression top
2. Stand collar
3. PWX Thermal, highly powerful, lightweight and flexible compression fabric
4. Soft brushed internal construction for warmth
5. Compression support for reduced muscle damage
6. PWX Vent splicing under the arms
7. Flatlock seams to reduce chafe

Men:

Best For:	Cold Weather	Cold Weather
Colours:	BLK/SIL	BLK/SIL
Size Range:	XS, S, M, L, XL, XXL	XXS, XS, S, M, L, XL
Fabric:	PWX Thermal PWX Vent (Power, Weight, LightWeight, Flexibility) 75% Nylon 25% Lycra	PWX 70D Thermal (Power, Weight, Flexibility) 75% Nylon 25% Lycra

Light Speed

Run in near-weightless performance apparel. Super lightweight X-LITE fabric features a puffed construction so you never lose your cool, while minimalist design removes distractions so you can focus on your run.



MR6499a / WR6513a
Light Speed WP Jacket



MR6555a / WR6563a
Light Speed 1/2 Zip



Stay Dry

Advanced 20k/50k waterproof stretch membrane with adjustable hood and fully taped seams offers serious protection from rain whilst still remaining breathable.

Lightweight & Flexible

Lightweight articulated sleeves, an adjustable hood and hem and a full front zip with snap tab provides maximum movement and allows you to adjust airflow to your liking when the weather changes.

Packable Pocket

A chest zip pocket offers a bounce-free solution for securing phone, cards or keys while you run and place to pack your jacket when you are not wearing it.

Be Seen

Reflective logos and trims on arms and back provide 360 visibility in low-light conditions.

Garment Features:

1. Full zip packable jacket
2. 20,000mm waterproof / 50,000gm2 breathable 2.5L membrane
3. Environmentally responsible C6 DWR surface treatment
4. Fully taped seams
5. Adjustable hood with rear collar button storage
6. Chest pocket (jacket stow)
7. Signature reflective X on sleeve

	Men:	Women:
Best For:	Wet Weather	Wet Weather
Colours:	BLK/SRF, AME/ARF	BLK/SRF, CBY/CBF
Size Range:	XS, S, M, L, XL, XXL	XXS, XS, S, M, L, XL
Fabric:	100% Nylon with PU Membrane	100% Nylon with PU Membrane

Flexible Versatility

Ribbed raglan sleeves provide maximum movement, a 1/2 zip design lets you adjust exposure to the elements to your liking while thumbholes at sleeve cuffs provide extra warmth and coverage on cooler days.

Quick-Drying

Quick dry, lightweight moisture-wicking fabric pulls sweat away from the skin while mesh panels across back allow air to flow freely.

Be Seen

Reflective logos and colour hit through ribbed shoulder provide visibility in low-light conditions.

Best For:	Mild Weather
Colours:	BLK/SRF, TRB/SRF, AME/BRF
Size Range:	XS, S, M, L, XL, XXL
Fabric:	Single Jersey: 88% Polyester 12% Spandex Mesh: 92% Polyester 8% Spandex Rib: 90% Polyester 10% Spandex

Garment Features:

1. 1/2 zip long sleeve
2. Stand collar
3. Lightweight moisture-wicking jersey on front and arms
4. Mesh back panel
5. Two-tone ribbed shoulders
6. Thumbholes at sleeve cuffs
7. Reflective logos and trims

Best For:	Mild Weather
Colours:	BLK/SRF, CBY/BRF, MDN/WRF
Size Range:	XXS, XS, S, M, L, XL
Fabric:	Single Jersey: 88% Polyester 12% Spandex Mesh: 92% Polyester 8% Spandex Rib: 90% Polyester 10% Spandex



MR6503a / WR6517a
Light Speed
Tech Tee

Ultimate Cooling

Mesh ventilation zones are engineered into the chest and centre back, keeping you cool where you need it the most.

Lightweight

Super lightweight X-LITE fabric uses a puffed construction for a near-weightless performance.

Quick-Drying

High-filament polyester yarn blocks UV and provides rapid moisture dispersal to keep you cool and dry.

Be Seen

Reflective logos and trims provide 360 visibility in low-light conditions.

Garment Features:

1. Set in short sleeve tee
2. Near-weightless 96gsm X-LITE fabric
3. Mesh ventilation zones engineered into chest, centre back and underarm.
4. Reflective logos and trims

	Men:	Women:
Best For:	Mild Weather, Hot Weather	Mild Weather, Hot Weather
Colours:	BLK/BRF, ECH/BRF	BLK/BRF, CBD/SRF
Size Range:	XS, S, M, L, XL, XXL	XXS, XS, S, M, L, XL
Fabric:	X-Lite 100% Polyester	X-Lite 100% Polyester



MR6501a / WR6515a
Light Speed
Tech Singlet

Ultimate Cooling

Mesh ventilation zones are engineered into the chest and centre back, keeping you cool where you need it the most.

Lightweight

Super lightweight X-LITE fabric uses a puffed construction for a near-weightless performance.

Quick-Drying

High-filament polyester yarn blocks UV and provides rapid moisture dispersal to keep you cool and dry.

Be Seen

Reflective logos and trims provide 360 visibility in low-light conditions.

Garment Features:

1. Singlet
2. Near-weightless 96gsm X-LITE fabric
3. Mesh ventilation zones engineered into chest and centre back.
4. Reflective logos and trims

	Men:	Women:
Best For:	Hot Weather	Hot Weather
Colours:	BLK/BRF, ECH/BRF	BLK/BRF, CBD/SRF
Size Range:	XS, S, M, L, XL, XXL	XXS, XS, S, M, L, XL
Fabric:	X-Lite 100% Polyester	X-Lite 100% Polyester



WR6214a
Light Speed
Hi-Impact Bra

Garment Features:

1. Breathable moulded foam cups
2. Internal underwire and stabilisers
3. Durable moisture-wicking fabric
4. Comfortable brushed underband elastic
5. 3-way adjustable padded shoulder straps
6. Centre back hook and eye closure

	Men:	Women:
Best For:	Cold Weather, Mild Weather, Hot Weather	Cold Weather, Mild Weather, Hot Weather
Colours:	BLK/BLK, ALP/PCL	BLK/BLK, ALP/PCL
Size Range:	32A,32B,32C,34A,34B,34C,36B,36C,36D,38B,38C,38D,40B,40C,40D	32A,32B,32C,34A,34B,34C,36B,36C,36D,38B,38C,38D,40B,40C,40D
Fabric:	Main: 80% Polyamide, 20% Elastane Liner: 82% Polyester, 8% Elastane Power Mesh: 62% Polyamide, 38% Elastane	Main: 80% Polyamide, 20% Elastane Liner: 82% Polyester, 8% Elastane Power Mesh: 62% Polyamide, 38% Elastane



MR6502a / WR6516a
Light Speed
Tee

Lightweight

Super lightweight X-LITE fabric uses a puffed construction for a near-weightless performance.

Moisture Wicking

High-filament polyester yarn blocks UV and provides rapid moisture dispersal to keep you cool and dry.

Be Seen

Reflective logos and trims provide 360 visibility in low-light conditions.

Garment Features:

1. Set in short sleeve tee
2. Near-weightless 96gsm X-LITE fabric
3. Reflective logos and trims

Men:

Best For: Mild Weather, Hot Weather
Colours: LGA/BRF, DCT/BRF
Size Range: XS, S, M, L, XL, XXL
Fabric: X-Lite 100% Polyester

Women:

Best For: Mild Weather, Hot Weather
Colours: INC/BRF, ELS/WRF
Size Range: XXS, XS, S, M, L, XL
Fabric: X-Lite 100% Polyester



MR6500a / WR6514a
Light Speed
Singlet

Lightweight

Super lightweight X-LITE fabric uses a puffed construction for a near-weightless performance.

Moisture Wicking

High-filament polyester yarn blocks UV and provides rapid moisture dispersal to keep you cool and dry.

Be Seen

Reflective logos and trims provide 360 visibility in low-light conditions.

Garment Features:

1. Singlet
2. Near-weightless 96gsm X-LITE fabric
3. Reflective logos and trims

Men:

Best For: Hot Weather
Colours: LGA/BRF, DCT/BRF
Size Range: XS, S, M, L, XL, XXL
Fabric: X-LITE 100% Polyester

Women:

Best For: Hot Weather
Colours: INC/BRF, ELS/WRF
Size Range: XXS, XS, S, M, L, XL
Fabric: X-LITE 100% Polyester



MR6507b / WR6521b
Light Speed
Jogger

Lightweight & Flexible

A lightweight, breathable 4-way stretch woven upper with inner leg gusset, has a sphere back texture to prevent cling and is combined with a PWX knit lower for ultimate flexibility in motion and moisture-wicking comfort.

Waistband Storage

A bonded waistband with internal drawcord ensures a secure fit while three back pockets providing storage for phone, cards and keys as well as gels.

Be Seen

Reflective logos and trims provide visibility in low-light conditions.



Garment Features:

1. Tapered jogger
2. Lightweight, breathable 4-way stretch woven upper
3. PWX highly powerful, lightweight and flexible compression fabric lower
4. Bonded waistband with internal draw cord
5. Inner leg gusset
6. Back zip pocket
7. Nutrition gel pockets
8. Reflective logos and trims

	Men:	Women:
Best For:	Mild Weather, Cold Weather	Cold Weather, Mild Weather
Colours:	BLK/BRF	BLK/BR, ALP/BRF
Size Range:	XS, S, M, L, XL, XXL	XXS, XS, S, M, L, XL
Fabric:	VAPOR+ PWX 70D Main: 82% Polyester 18% Spandex Lower Leg: 79% Nylon 21% Elastane	VAPOR+ PWX 70D Main: 82% Polyester 18% Spandex Lower Leg: 79% Nylon 21% Elastane



MR6504b / WR6518b
Light Speed
3" Shorts

Lightweight & Flexible

Lightweight, breathable 4-way stretch woven outer and inner brief liner combine for ultimate flexibility in motion and comfort.

Waistband Storage

A bonded waistband with internal drawcord ensures a secure fit while a centre back zip pocket lets you safely store phone, cards or keys and a hidden internal gel pocket provides space for your nutrition.

Be Seen

Reflective logos and trims provide 360 visibility in low-light conditions.



Garment Features:

1. 3" inseam short
2. Lightweight, breathable 4-way stretch woven outer
3. Brief liner
4. Bonded waistband with internal drawcord
5. Back zip pocket
6. Hidden internal gel pocket
7. Bonded hems
8. Reflective logo and trims

	Men:	Women:
Best For:	Hot Weather	Hot Weather
Colours:	BLK/BRF, DCT/BRF	BLK/BRF
Size Range:	XS, S, M, L, XL, XXL	XXS, XS, S, M, L, XL
Fabric:	Main: 86% Recycled Polyester 14% Elastane Liner: 88% Polyester 12% Spandex	Main: 86% Recycled Polyester 14% Elastane Liner: 88% Polyester 12% Spandex



MR6505b
Light Speed 7"
Cover Shorts

Garment Features:

1. 7" inseam short
2. Lightweight, breathable 4-way stretch woven outer
3. Inner leg gusset
4. Elasticised sides
5. Internal silicon grip print
6. Reflective logo and trims
7. Flatlock seams to reduce chafe

	Men:	Women:
Best For:	Hot Weather	Hot Weather
Colours:	BLK/BRF	BLK/BRF
Size Range:	XS, S, M, L, XL, XXL	XS, S, M, L, XL, XXL
Fabric:	79% Polyamide 21% Elastane	79% Polyamide 21% Elastane

Light Speed Compression

Light Speed Compression, with revolutionary Muscle Containment Stamping (MCS) technology, has been developed with a detailed understanding of the impact running has on the legs, reducing muscle movement, damage and fatigue for your best run yet.



MA5305b
Light Speed Compression Tights

Garment Features:

1. PWX highly powerful, lightweight and flexible compression fabric
2. MCS on Calf & Quadriceps
3. Drawstring waistband for adjustable secure fit
4. Graduated compression for improved blood flow, aiding faster warm-up and recovery
5. Large pocket for phone
6. Zip pocket for cards and keys
7. Mesh pocket for gels and other items
8. Signature reflective X logos on thigh and calf
9. Flatlock seams to reduce chafe

Best For: Mild Weather

Colours: BLK/GRF, BLK/BRF, BLK/ARF

Size Range: XXS, XS, S, ST, M, MT, L, LT, XL, XLT, XXL, XXXL

Rise: Regular

Waistband: 3.5cm covered elastic with drawstring

Fabric: Front: PWX Flex 70D 72% Nylon, 28% Lycra
Back: PWX Weight 105D 65% Nylon, 35% Lycra (Power, Weight, Flexibility)



WA6523b
Light Speed Mid-Rise Compression Tights

Garment Features:

1. Full length compression tight
2. PWX highly powerful, lightweight and flexible compression fabric
3. Quadriceps MCS
4. Calf MCS
5. Mid-Rise power mesh waistband for body sculpting secure fit
6. Graduated compression for improved circulation
7. Large pocket for phone
8. Zip pocket for cards and keys
9. Mesh pocket for gels
10. Reflective X logos for greater visibility
11. Flatlock seams to reduce chafe

Best For: Mild Weather

Colours: BLK/BRF, BLK/GRF, BLK/CBF

Size Range: XXS, XS, XST, S, ST, M, MT, L, LT, XL, XXL

Rise: Mid-Rise

Waistband: 8cm power mesh

Fabric: Front: PWX 70D. 72% Nylon, 28% Lycra
Back: PWX 160D. 65% Nylon, 35% Lycra (Power, Weight, Flexibility)



WA6528b
Light Speed Mid-Rise Compression 3/4 Tights

Garment Features:

1. 3/4 compression tight
2. PWX highly powerful, lightweight and flexible compression fabric
3. Quadriceps MCS
4. Mid-Rise power mesh waistband for body sculpting secure fit
5. Large pocket for phone
6. Zip pocket for cards and keys
7. Mesh pocket for gels
8. Reflective X logo for greater visibility
9. Flatlock seams to reduce chafe

Best For: Mild Weather, Hot Weather

Colours: BLK/BRF, BLK/GRF, BLK/CBF

Size Range: XXS, XS, XST, S, ST, M, MT, L, LT, XL, XXL

Rise: Mid Rise

Waistband: 8cm power mesh

Fabric: Front: PWX 70D. 72% Nylon, 28% Lycra
Back: PWX 160D. 65% Nylon, 35% Lycra (Power, Weight, Flexibility)



MA5331b
Light Speed
Compression Shorts

Garment Features:

1. PWX highly powerful, lightweight and flexible compression fabric
2. Quadriceps MCS
3. Drawstring waistband for adjustable secure fit
4. Large pocket for phone
5. Zip pocket for cards and keys
6. Mesh pocket for gels and other items
7. Signature reflective X logo on thigh
8. Flatlock seams to reduce chafe

Best For: Hot Weather

Colours: BLK/GRF, BLK/BRF, BLK/ARF

Size Range: XXS, XS, S, M, L, XL, XXL, XXXL

Rise: Regular

Waistband: 3.5cm covered elastic with drawstring

Fabric: Front: PWX Flex 70D 72% Nylon, 28% Lycra
Back: PWX Weight 105D 65% Nylon, 35% Lycra
(Power, Weight, Flexibility)



WA6593b
Light Speed Mid-Rise Compression
Shorts

Garment Features:

1. Compression short
2. PWX highly powerful, lightweight and flexible compression fabric
3. Quadriceps MCS
4. Mid-Rise power mesh waistband for body sculpting secure fit
5. Large pocket for phone
6. Zip pocket for cards and keys
7. Mesh pocket for gels
8. Reflective X logo for greater visibility
9. Flatlock seams to reduce chafe

Best For: Hot Weather

Colours: BLK/GRF

Size Range: XXS, XS, S, M, L, XL, XXL

Rise: Mid Rise

Waistband: 8cm power mesh

Fabric: Front: PWX 70D. 72% Nylon, 28% Lycra
Back: PWX 160D. 65% Nylon, 35% Lycra
(Power, Weight, Flexibility)

Aero

Stay cool and on track throughout every run. Featuring X-VENT fabric technology, the AERO range wicks away sweat while aiding ventilation, keeping you dry and cool so you can perform in comfort.



MR6537a / WR6538a

Aero Jacket

Stay Dry

Stretch woven shell with adjustable 3 piece hood and environmentally responsible C6 DWR treatment to withstand rain and showers.

Stay Cool

Back vent with power mesh lining to enhance breathability and ventilation.

Essential Storage

Front zip hand pockets for storing cards or keys while you run.

Be Seen

Reflective logos and trims provide 360 visibility in low-light conditions.



Garment Features:

1. Full zip jacket
2. Stretch woven water-resistant shell
3. Environmentally responsible C6 DWR surface treatment
4. Adjustable 3 piece hood
5. Back vent with power mesh lining
6. Front zip pockets
7. Reflective logos and trims

	Mens:	Womens:
Best For:	Wet Weather, Mild Weather	Wet Weather, Mild Weather
Colours:	BLK/SRF, ALP/KRF, ELY/BRF	BLK/SRF, PCL/ORF, ELY/BRF
Size Range:	XS, S, M, L, XL, XXL	XXS, XS, S, M, L, XL
Fabric:	100% Polyester	100% Polyester



MR6556a / WR6564a

Aero Long Sleeve Tee

Stay Cool

Lightweight mesh back panel engineered to enhance breathability and ventilation.

Quick-Drying

Double-knit constructed main panel leverages an inner layer to transport sweat away from skin and an outer layer to disperse moisture on surface, delivering rapid moisture management.

Be Seen

Reflective logos and trims on front, arms and back provide 360 visibility in low-light conditions.



Garment Features:

1. Raglan long sleeve top
2. Double-knit moisture-wicking fabric main panel
3. Lightweight breathable mesh back panel
4. Reflective logos and trims

	Mens:	Womens:
Best For:	Mild Weather	Mild Weather
Colours:	BLK/SRF, RUS/BRF	WHT/SRF, ALP/SRF
Size Range:	XS, S, M, L, XL, XXL	XXS, XS, S, M, L, XL
Fabric:	X-VENT Main: 100% Polyester Mesh: 100% Polyester	X-VENT Main: 100% Polyester Mesh: 100% Polyester



MR6557a / WR6565a
Aero Short Sleeve Tee

Stay Cool

Lightweight mesh back panel engineered to enhance breathability and ventilation.

Quick-Drying

Double-knit constructed main panel leverages an inner layer to transport sweat away from skin and an outer layer to disperse moisture on surface, delivering rapid moisture management.

Be Seen

Reflective logos and trims on front, arms and back provide 360 visibility in low-light conditions.



Garment Features:

1. Raglan short sleeve tee
2. Double-knit moisture-wicking fabric main panel
3. Lightweight breathable mesh back panel
4. Reflective logos and trims

	Mens:	Womens:
Best For:	Mild Weather, Hot Weather	Mild Weather, Hot Weather
Colours:	BLK/SRF, WHT/SRF, ALP/KRF, OAT/BRF, RUS/BRF	BLK/SRF, WHT/SRF, ALP/SRF, PCL/WRF, LLT/SRF
Size Range:	XS, S, M, L, XL, XXL	XXS, XS, S, M, L, XL
Fabric:	X-VENT Main: 100% Polyester Mesh: 100% Polyester	X-VENT Main: 100% Polyester Mesh: 100% Polyester



MR6559a / WR6566a
Aero Singlet

Stay Cool

Lightweight mesh back panel engineered to enhance breathability and ventilation.

Quick-Drying

Double-knit constructed main panel leverages an inner layer to transport sweat away from skin and an outer layer to disperse moisture on surface, delivering rapid moisture management.

Be Seen

Reflective logos and trims on front, arms and back provide 360 visibility in low-light conditions.



Garment Features:

1. Singlet
2. Double-knit moisture-wicking fabric main panel
3. Lightweight breathable mesh back panel
4. Reflective logos and trims

	Mens:	Womens:
Best For:	Hot Weather	Hot Weather
Colours:	BLK/SRF, RUS/BRF, ALP/KRF	BLK/SRF, WHT/SRF, ALP/SRF, PCL/WRF, LLT/SRF
Size Range:	XS, S, M, L, XL, XXL	XXS, XS, S, M, L, XL
Fabric:	X-VENT Main: 100% Polyester Mesh: 100% Polyester	X-VENT Main: 100% Polyester Mesh: 100% Polyester



MR6558a
Aero Tank

Garment Features:

1. Tank
2. Double-knit moisture-wicking fabric main panel
3. Lightweight breathable mesh back panel
4. Reflective logos and trims

	Mens:	Womens:
Best For:	Hot Weather	Hot Weather
Colours:	BLK/SRF, WHT/SRF, ALP/KRF, OAT/BRF, RUS/BRF	BLK/SRF, WHT/SRF, ALP/KRF, OAT/BRF, RUS/BRF
Size Range:	XS, S, M, L, XL, XXL	XS, S, M, L, XL, XXL
Fabric:	X-VENT Main: 100% Polyester Mesh: 100% Polyester	X-VENT Main: 100% Polyester Mesh: 100% Polyester



WR6347a
Aero Medium
Impact Bra

Garment Features:

1. Medium impact support bra
2. Supportive moulded cups
3. Adjustable wide elastic straps
4. Breathable perforated fabric
5. Centre back hook and eye closure



Firm Muscle Support

Lightweight yet powerful PWX fabric inner, reduces muscle movement lowering risk of injury whilst ensuring optimal positioning to improve performance.

Lightweight & Flexible

Perforated lightweight stretch woven outer enhances ventilation to keep you cool.

Essential Storage

Easy-access phone pocket on compression inner, plus a zip pocket to secure valuables.

Be Seen

Reflective logos and trims on front and back hem provide 360 visibility in low-light conditions.

Best For: Cold Weather, Mild Weather, Hot Weather
Colours: BLK/BLK, CBY/CBY
Size Range: XXS, XS, S, M, L, XL
Fabric: Main: 77% Nylon 23% Elastane
 Mesh: 71% Polyamide 29% Elastane



MR6536b
Aero 2-In-1
7" Shorts

Garment Features:

1. Perforated 7" inseam, stretch woven short
2. Inner PWX compression short
3. Flat elastic waistband with internal drawcord
4. Side zip pocket
5. Phone pocket on internal compression liner
6. Reflective logos and trims

Best For: Hot Weather

Colours: BLK/SRF, TRB/SRF
Size Range: XS, S, M, L, XL, XXL
Fabric: PWX 70D (Power, Weight, Flexibility)
 Outer: 100% Polyester
 Inner: 72% Nylon 28% Lycra



MR6535b
Aero 2-In-1
5" Shorts

Garment Features:

1. Perforated 5" inseam, stretch woven short
2. Inner PWX compression short
3. Flat elastic waistband with internal drawcord
4. Side zip pocket
5. Phone pocket on internal compression liner
6. Reflective logos and trims

Best For: Hot Weather

Colours: BLK/SRF, TRB/SRF
Size Range: XS, S, M, L, XL, XXL
Fabric: PWX 70D (Power, Weight, Flexibility)
 Outer: 100% Polyester.
 Inner: 72% Nylon 28% Lycra



WR6533b
Aero 2-In-1
3" Shorts

Garment Features:

1. 3" inseam stretch woven short
2. Inner PWX short liner
3. Comfortable stretch waistband
4. Back zip pocket
5. Reflective logos and trims

Best For: Hot Weather

Colours: BLK/SRF, OAT/ORF
Size Range: XXS, XS, S, M, L, XL
Fabric: PWX 70D (Power, Weight, Flexibility)
 Outer: 100% Polyester
 Inner: 72% Nylon 28% Lycra



MR6531b
Aero 7"
Shorts

Garment Features:

1. 7" inseam short
2. Lightweight stretch woven
3. Brief liner
4. Elastic waistband with internal drawcord
5. Back zip pocket
6. Reflective logo and trims

Best For:	Hot Weather
Colours:	BLK/SRF, MDN/SRF, ALP/KRF, OAT/BRF
Size Range:	XS, S, M, L, XL, XXL
Fabric:	100% Polyester



MR6532b
Aero 5"
Shorts

Garment Features:

1. 5" inseam short
2. Lightweight stretch woven
3. Brief liner
4. Elastic waistband with internal drawcord
5. Back zip pocket
6. Reflective logo and trims

Best For:	Hot Weather
Colours:	BLK/SRF, MDN/SRF, ALP/KRF, OAT/BRF
Size Range:	XS, S, M, L, XL, XXL
Fabric:	100% Polyester



WR6534b
Aero
4" Shorts

Garment Features:

1. 4" inseam short
2. Lightweight stretch woven
3. Brief liner
4. Comfortable knit waistband
5. Back zip pocket
6. Reflective logo and trims

Best For:	Hot Weather
Colours:	BLK/SRF, ALP/SRF, PCL/WRF
Size Range:	XXS, XS, S, M, L, XL
Fabric:	100% Polyester

Lightweight & Flexible

Lightweight stretch woven fabric is flexible and moisture-wicking for ultimate comfort.

Essential Storage

A back zip pockets lets you safely store phone, cards or keys.

Be Seen

Reflective logos and trims on front and back hem provide 360 visibility in low-light conditions.



MR6508b
Aero Woven
Jogger

Stay Cool

Lightweight stretch woven fabric delivers rapid moisture-wicking whilst strategically placed perforations behind the back of the knees provide ventilation to keep you cool.

Total Comfort

Elastic waistband with internal drawcord provides a secure fit while ankle zips help adjust level of cooling and allow joggers to be easily removed over shoes.

Essential Storage

Side pockets and a zip media pocket on the centre-back provide ample storage to secure your valuables.

Be Seen

Reflective logos and trims on the thigh and back of knees provide 360 visibility in low-light conditions.

Garment Features:

1. Tapered jogger
2. Lightweight stretch woven
3. Elastic waistband with internal drawcord
4. Side pockets
5. Zip media pocket on the centre-back
6. Laser cut perforations at back of knees
7. Ankle zips
8. Reflective logos and trims

Best For:	Mild Weather
Colours:	BLK/SRF, TRB/SRF
Size Range:	XS, S, M, L, XL, XXL
Fabric:	82% Polyester 18% Spandex



WA6413b
Aero Reflect Hi-Rise
Comp Tights

Be Seen

All over tonal reflective print, provides 360 visibility in low-light conditions.

Firm Muscle Support

Lightweight yet powerful PWX fabric reduces muscle movement and damage whilst compression boosts blood flow to muscles, improving performance, lowering risk of injury and speeding up recovery.

Multiple Pockets

Extra high figure flattering, slimming and secure waistband includes a zip back pocket and side pockets, providing ample bounce-free secure storage for phone, cards and keys.

Total Comfort

High quality, durable, moisture-wicking yarns outlast the competition to provide squat proof coverage and keep the skin cool and dry.



Garment Features:

1. Full length compression tight
2. PWX highly powerful, lightweight and flexible compression fabric
3. Graduated compression for improved circulation
4. Hi-Rise figure flattering, slimming and secure fit waistband
5. All over subtle tonal reflective print
6. Rear zip pocket
7. Side pockets
8. Signature reflective X logo
9. Flatlock seams to reduce chafe

Best For:	Mild Weather
Colours:	IRF/SRF
Size Range:	XXS, XS, XST, S, ST, M, MT, L, LT, XL, XXL
Rise:	Hi-Rise
Waistband:	12cm power mesh
Fabric:	Front: PWX 70D. 72% Nylon, 28% Lycra Back: PWX 160D. 65% Nylon, 35% Lycra (Power, Weight, Flexibility)



WA6522b
Aero Reflect Hi-Rise
Comp Shorts

Garment Features:

1. Compression short
2. PWX highly powerful, lightweight and flexible compression fabric
3. Hi-Rise figure flattering, slimming and secure fit waistband
4. All over subtle tonal reflective print
5. Rear zip pocket
6. Side pockets
7. Signature reflective X logo
8. Flatlock seams to reduce chafe

Best For:	Hot Weather
Colours:	IRF/SRF
Size Range:	XXS, XS, XST, S, ST, M, MT, L, LT, XL, XXL
Rise:	Hi-Rise
Waistband:	12cm power mesh
Fabric:	Front: PWX 70D. 72% Nylon, 28% Lycra Back: PWX 160D. 65% Nylon, 35% Lycra (Power, Weight, Flexibility)



WA6527b
**Aero Sculpt Hi-Rise
 Comp Tights**

Minimal Seaming

No side seam construction ensures an uninterrupted smooth body sculpting fit.

Firm Muscle Support

Lightweight yet powerful PWX fabric reduces muscle movement and damage whilst graduated compression boosts blood flow to muscles, improving performance, lowering risk of injury and speeding up recovery.

Waistband Storage

Extra high figure flattering, slimming and secure waistband includes a zip back pocket providing bounce-free secure storage for phone, cards and keys.

Total Comfort

High quality, durable, moisture-wicking yarns outlast the competition to provide squat proof coverage and keep the skin cool and dry.

Garment Features:

1. Full length compression tight
2. PWX highly powerful, lightweight and flexible compression fabric
3. Graduated compression for improved circulation
4. Hi-Rise figure flattering, slimming and secure fit waistband
5. Body sculpting no side seam construction
6. Rear zip pocket
7. Contrast striped plastisol print across thigh and calf
8. Flatlock seams to reduce chafe

Best For:	Mild Weather
Colours:	MDN/ELS
Size Range:	XXS, XS, XST, S, ST, M, MT, L, LT, XL, XXL
Rise:	Hi-Rise
Waistband:	12cm power mesh
Fabric:	PWX Weight 105D (Power, Weight, Flexibility) 65% Nylon, 35% Lycra

Aero Vent

Designed to alleviate overheating whilst running, the Aero Compression Tights feature PWX VENT panels to improve air flow and keep you cool when your run heats up.



MA6529b
Aero Vent
Compression Tights

Garment Features:

1. Full length compression tights
2. Upper leg PWX highly powerful, lightweight and flexible compression fabric
3. Lower leg PWX VENT panels increase airflow
4. Graduated compression for improved circulation
5. Drawstring waistband for adjustable secure fit
6. Rear zip pocket for secure bounce-free storage
7. Signature reflective X logo on thigh
8. Flatlock seams to reduce chafe

Best For: Mild Weather, Hot Weather
Colours: BLK/SRF
Size Range: XXS, XS, S, ST, M, MT, L, LT, XL, XLT, XXL, XXXL
Rise: Regular
Waistband: 3.5cm covered elastic with drawstring
Fabric: Upper front: PWX 70D. 75% Nylon, 25% Lycra
 Upper back: PWX 105D. 65% Nylon, 35% Lycra
 Lower leg: PWX VENT. 65% Nylon, 35% Lycra (Power, Weight, Flexibility)



WA6519b
Aero Vent Mid-Rise Compression
Tights

Garment Features:

1. Full length compression tights
2. Lower leg ventilated PWX Dash Mesh panels
3. PWX highly powerful, lightweight and flexible compression fabric upper leg panels
4. Graduated compression for improved circulation
5. Mid-Rise power mesh waistband for body sculpting secure fit
6. Rear zip pocket for secure bounce-free storage
7. Signature reflective X logo on thigh
8. Flatlock seams to reduce chafe

Best For: Mild Weather, Hot Weather
Colours: BLK/SRF
Size Range: XXS, XS, XST, S, ST, M, MT, L, LT, XL, XXL
Rise: Mid-Rise
Waistband: 8cm power mesh
Fabric: Upper front: PWX Flex 70D
 75% Nylon, 25% Lycra
 Upper back: PWX Weight 160D
 65% Nylon, 35% Lycra
 Lower leg: PWX Dash mesh 105D
 65% Nylon, 35% Lycra
 (Power, Weight, Flexibility)



WA6520b
Aero Vent Mid-Rise Compression
3/4 Tights

Garment Features:

1. 3/4 compression tights
2. Lower leg ventilated PWX Dash Mesh panels
3. PWX highly powerful, lightweight and flexible compression fabric upper leg panels
4. Mid-Rise power mesh waistband for body sculpting secure fit
5. Rear zip pocket for secure bounce-free storage
6. Signature reflective X logo on thigh
7. Flatlock seams to reduce chafe

Best For: Hot Weather
Colours: BLK/SRF
Size Range: XXS, XS, XST, S, ST, M, MT, L, LT, XL, XXL
Rise: Mid-Rise
Waistband: 8cm power mesh
Fabric: Upper front: PWX Flex 70D
 75% Nylon, 25% Lycra
 Upper back: PWX Weight 160D
 65% Nylon, 35% Lycra
 Lower leg: PWX Dash mesh 105D
 65% Nylon, 35% Lycra
 (Power, Weight, Flexibility)

Stay Cool

Lower leg PWX VENT panels provide support whilst improving air flow by almost 200%, increasing evaporation of your sweat to keep you at optimal performance temperature.

Lightweight & Flexible Support

Powerful, lightweight PWX fabric with circular knit 360-degree stretch, reduces muscle movement and damage whilst maintaining flexibility for ultimate sports performance.

Graduated Compression

Firm graduated compression boosts blood flow to muscles, improving performance, lowering risk of injury and speeding up recovery.

Quick-Drying

High quality, durable, moisture-wicking yarns outlast the competition and keep the skin cool and dry.

Be Seen

Signature reflective X logo on thigh provides visibility in low-light conditions.



MA6108b
**Aero Vent
Compression Shorts**

Garment Features:

1. Compression short
2. Upper leg PWX highly powerful, lightweight and flexible compression
3. Lower leg PWX VENT panels increase airflow
4. Drawstring waistband for adjustable secure fit
5. Rear zip pocket for secure bounce-free storage
6. Signature reflective X logo on thigh
7. Flatlock seams to reduce chafe

Best For: Hot Weather

Colours: BLK/SRF

Size Range: XXS, XS, S, M, L, XL, XXL, XXXL

Rise: Regular

Waistband: 3.5cm covered elastic with drawstring

Fabric: Upper front: PWX 70D. 75% Nylon, 25% Lycra
Upper back: PWX 105D. 65% Nylon, 35% Lycra
Lower thigh: PWX VENT. 65% Nylon, 35% Lycra
(Power, Weight, Flexibility)



WA6182b
**Aero Vent Mid-Rise Compression
Shorts**

Garment Features:

1. Compression short
2. Ventilated PWX Dash Mesh panels
3. PWX highly powerful, lightweight and flexible compression fabric upper leg panels
4. Mid-Rise power mesh waistband for body sculpting secure fit
5. Rear zip pocket for secure bounce-free storage
6. Signature reflective X logo on thigh
7. Flatlock seams to reduce chafe

Best For: Hot Weather

Colours: BLK/SRF

Size Range: XXS, XS, XST, S, ST, M, MT, L, LT, XL, XXL

Rise: Mid-Rise

Waistband: 8cm power mesh

Fabric: Upper front: PWX Flex 70D
75% Nylon, 25% Lycra
Upper back: PWX Weight 160D
65% Nylon, 35% Lycra
Lower thigh: PWX Dash mesh 105D
65% Nylon, 35% Lycra
(Power, Weight, Flexibility)

ENDURANCE

GO-TO-MARKET

SERVING THE MOST DEMANDING ATHLETES WITH THE HIGHEST PERFORMING PRODUCT FROM THE START TO FINISH LINE.

CONSUMER PROFILE

The original misfits, endurance athletes are all shapes and sizes, all abilities and all ages. They are all chasing the finish line, some are after Olympic Gold or World Championships, others, just celebrating with their team at the local race. They all seek comfort and performance, no matter their level.

COLLECTIONS GUIDE

COMPRESSION

The ultimate weapon for racing at all distances.

PERFORM

Stand-out performance across long and short course racing.

ACTIVE

Take your race day to the next level.

PROPEL

Speed, buoyancy and performance in the water.



MARKETING SUPPORT

GOAL Lead and drive the market with innovations across triathlon and wetsuits, breaking records and setting new boundaries.

NOW Re-establishing our market strength through connecting with community and being the first-choice endurance brand on the market.

Print Advertising
Digital Advertising
Social Media
Trade Marketing
Visual Merchandising
Seeding Packs
Ambassador Marketing
Athlete Marketing
Community and Event Marketing

Compression Tri

Designed in accordance with RMIT University research, the Compression Tri range features the latest in triathlon innovation, delivering big on performance - think superior muscle stabilization, heat-beating technology and unrivaled aerodynamics.

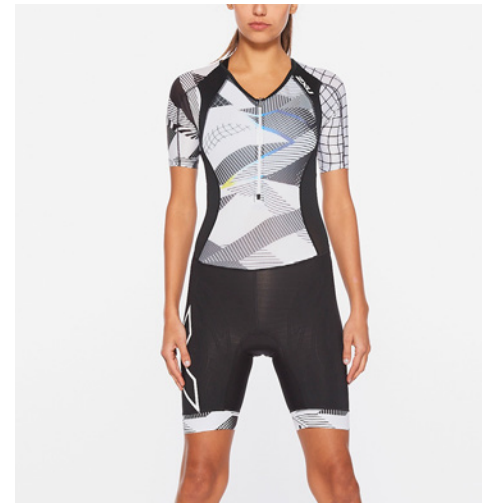
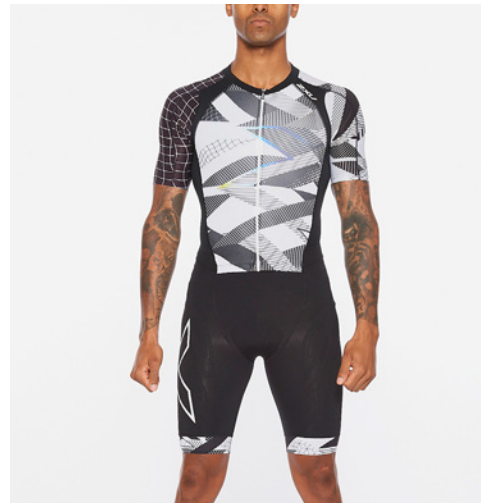

MT5516d / WT5521d
Compression Full Zip Sleeved Trisuit

Ultimate Cooling

PWX VENT lower body provides support whilst improving air flow by almost 200% whilst Swiss COLDBLACK® on upper body reduces absorption of heat rays and provides UV protection to keep you at optimal performance temperature.

Muscle Containment Stamping (Mcs)

Muscle Containment Stamping (MCS) traces quadriceps, dissipating the load transfer on the knee joint during running.

Lightweight & Flexible Support

Powerful, lightweight PWX fabric with circular knit 360-degree stretch, reduces muscle movement and prevents fatigue.

Unrivaled Aerodynamics

The 3D mesh structure of premium Italian SBR VENT through upper body provides exceptional aerodynamics and is ergonomically engineered to fit to your body like a second skin.

Pro Ld Chamois

Made from low profile 90 density 6mm high impact perforated foam, this chamois provides support in the aero position and is quick-drying for less bulk on the run.

Essential Storage

Easily accessible rear pockets provide adequate storage for your race-day essentials.

Garment Features:

1. Sleeved trisuit
2. Ergonomically engineered panelling
3. Powerful, lightweight PWX VENT lower body
4. Quadriceps Muscle Containment Stamping (MCS)
5. Premium Italian SBR VENT upper body
6. Advanced Swiss COLDBLACK® upper body and back yoke
7. Premium Italian-engineered silicone leg grippers
8. Low profile Pro LD chamois
9. Full length semi-auto lock zip
10. Easily accessible rear pockets

Men:

Best For: Mild Weather, Hot Weather
Colours: BLK/CRO, BLK/GLD
Size Range: XS, S, M, L, XL, XXL
Fabric: Swiss Vent, 105 PWX Compression, 105D PWX Power Mesh, SBR Vent.
 Solid Swiss Vent: 80% Nylon / 13% Polyester / 7% Elastane, Printed Swiss Vent: 90% Polyester / 10% Lycra, 105D PWX Compression: 65% Nylon / 35% Lycra, 105D PWX Power Mesh: 68% Nylon / 32% Lycra, SBR Vent: 81% Microfibre Polyester / 6% Polyester / 13% Elastane

Women:

Best For: Mild Weather, Hot Weather
Colours: BLK/CRO, BLK/GLD
Size Range: XXS, XS, S, M, L, XL
Fabric: Swiss Vent, 105 PWX Compression, 105D PWX Power Mesh, SBR Vent. Solid Swiss Vent: 80% Nylon / 13% Polyester / 7% Elastane, Printed Swiss Vent: 90% Polyester / 10% Lycra, 105D PWX Compression: 65% Nylon / 35% Lycra, 105D PWX Power Mesh: 68% Nylon / 32% Lycra, SBR Vent: 81% Microfibre Polyester / 6% Polyester / 13% Elastane



MT5517d / WT5522d
Compression Full Zip
Trisuit

Garment Features:

1. Sleeveless trisuit
2. Ergonomically engineered panelling
3. Powerful, lightweight PWX VENT lower body
4. Quadriceps Muscle Containment Stamping (MCS)
5. Premium Italian SBR VENT upper body

6. Advanced Swiss COLDBLACK® upper body and back yoke
7. Premium Italian-engineered silicone leg grippers
8. Low profile Pro LD chamois
9. Full length semi-auto lock zip
10. Easily accessible rear pockets

Best For: Mild Weather, Hot Weather
Colours: BLK/CRO, BLK/GLD
Size Range: XS, S, M, L, XL, XXL
Fabric: Swiss Vent, 105 PWX Compression, 105D PWX Power Mesh, SBR Vent. Solid Swiss Vent: 80% Nylon / 13% Polyester / 7% Elastane, Printed Swiss Vent: 90% Polyester / 10% Lycra, 105D PWX Compression: 65% Nylon / 35% Lycra, 105D PWX Power Mesh: 68% Nylon / 32% Lycra, SBR Vent: 81% Microfibre Polyester / 6% Polyester / 13% Elastane

Best For: Mild Weather, Hot Weather
Colours: BLK/CRO, BLK/GLD
Size Range: XXS, XS, S, M, L, XL
Fabric: Swiss Vent, 105 PWX Compression, 105D PWX Power Mesh, SBR Vent. Solid Swiss Vent: 80% Nylon / 13% Polyester / 7% Elastane, Printed Swiss Vent: 90% Polyester / 10% Lycra, 105D PWX Compression: 65% Nylon / 35% Lycra, 105D PWX Power Mesh: 68% Nylon / 32% Lycra, SBR Vent: 81% Microfibre Polyester / 6% Polyester / 13% Elastane

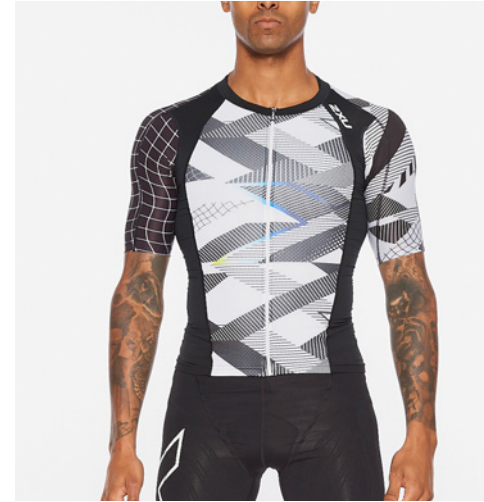

MT5518a / WT6058a
Compression Sleeved
Top

Ultimate Cooling

Swiss COLDBLACK® reduces absorption of heat rays and provides UV protection to keep you at optimal performance temperature.

Unrivalled Aerodynamics

The 3D mesh structure of premium Italian SBR VENT through upper body provides exceptional aerodynamics and is ergonomically engineered to fit to your body like a second skin.

Essential Storage

Easily accessible rear pockets provide adequate storage for your race-day essentials.

Garment Features:

1. Sleeved tri top
2. Ergonomically engineered panelling
3. Premium Italian SBR VENT upper body
4. Advanced Swiss COLDBLACK® upper body and back yoke
5. Full length semi-auto lock zip
6. Easily accessible rear pockets

Best For: Mild Weather, Hot Weather
Colours: BLK/CRO, BLK/GLD
Size Range: XS, S, M, L, XL, XXL
Fabric: Swiss Vent, SBR Vent. Solid Swiss Vent: 80% Nylon / 13% Polyester / 7% Elastane, Printed Swiss Vent: 90% Polyester / 10% Lycra, SBR Vent: 81% Microfibre Polyester / 6% Polyester / 13% Elastane

Best For: Mild Weather, Hot Weather
Colours: BLK/GLD
Size Range: XXS, XS, S, M, L, XL
Fabric: Swiss Vent, SBR Vent. Solid Swiss Vent: 80% Nylon / 13% Polyester / 7% Elastane, Printed Swiss Vent: 90% Polyester / 10% Lycra, SBR Vent: 81% Microfibre Polyester / 6% Polyester / 13% Elastane

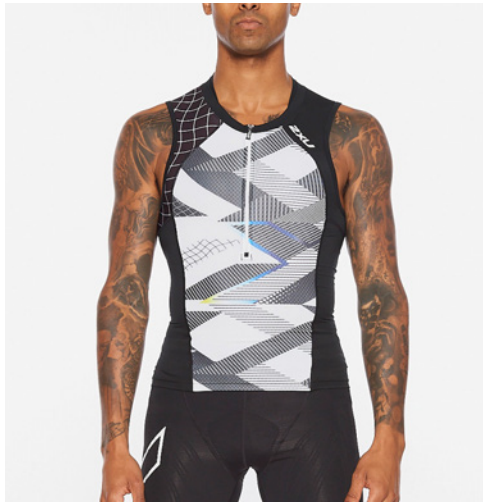

MT5519a / WT5523a
Compression
Tri Singlet

Ultimate Cooling

Swiss COLDBLACK® reduces absorption of heat rays and provides UV protection to keep you at optimal performance temperature.

Unrivalled Aerodynamics

The 3D mesh structure of premium Italian SBR VENT through upper body provides exceptional aerodynamics and is ergonomically engineered to fit to your body like a second skin.

Essential Storage

Easily accessible rear pockets provide adequate storage for your race-day essentials.

Men:

Best For: Mild Weather, Hot Weather
Colours: BLK/CRO, BLK/GLD
Size Range: XS, S, M, L, XL, XXL
Fabric: Swiss Vent, SBR Vent. Solid Swiss Vent: 80% Nylon / 13% Polyester / 7% Elastane, Printed Swiss Vent: 90% Polyester / 10% Lycra, SBR Vent: 81% Microfibre Polyester / 6% Polyester / 13% Elastane

Garment Features:

1. Tri singlet
2. Ergonomically engineered panelling
3. Premium Italian SBR VENT upper body
4. Advanced Swiss COLDBLACK® upper body and back yoke
5. 1/4 length semi-auto lock zip
6. Easily accessible rear pockets

Women:

Best For: Mild Weather, Hot Weather
Colours: BLK/CRO, BLK/GLD
Size Range: XXS, XS, S, M, L, XL
Fabric: Swiss Vent, SBR Vent. Solid Swiss Vent: 80% Nylon / 13% Polyester / 7% Elastane, Printed Swiss Vent: 90% Polyester / 10% Lycra, SBR Vent: 81% Microfibre Polyester / 6% Polyester / 13% Elastane



MT5520b / WT5524b
Compression
Tri Short

Ultimate Cooling

PWX VENT lower body provides support whilst improving air flow by almost 200% to keep you at optimal performance temperature.

Muscle Containment Stamping (MCS)

Muscle Containment Stamping (MCS) traces quadriceps; dissipating the load transfer on the knee joint during running.

Lightweight & Flexible Support

Powerful, lightweight PWX fabric with circular knit 360-degree stretch, reduces muscle movement and prevents fatigue.

Pro Ld Chamois

Made from low profile 90 density 6mm high impact perforated foam, this chamois provides support in the aero position and is quick-drying for less bulk on the run.

Essential Storage

Easily accessible rear pockets provide adequate storage for your race-day essentials.

Garment Features:

1. Men: 9" inseam tri shorts
2. Women: 7" inseam tri shorts
3. Ergonomically engineered panelling
4. Powerful, lightweight PWX VENT lower body
5. Quadriceps Muscle Containment Stamping (MCS)
6. Premium Italian-engineered silicone leg grippers
7. Low profile Pro LD chamois
8. Easily accessible rear pockets

Men:

Best For: Mild Weather, Hot Weather
Colours: BLK/WHT, BLK/GLD
Size Range: XS, S, M, L, XL, XXL
Fabric: 105D PWX Compression, 105 PWX Power Mesh, Italian Leg Gripper. 105D PWX Compression: 65% Nylon / 35% Lycra, 105 PWX Power Mesh: 68% Nylon / 32% Lycra, Italian Leg Gripper: 80% Polyester / 20% Elastane

Women:

Mild Weather, Hot Weather
 BLK/WHT, BLK/GLD
 XXS, XS, S, M, L, XL
 105D PWX Compression, 105 PWX Power Gripper. 105D PWX Compression: 65% Nylon / 35% Lycra, 105 PWX Power Mesh: 68% Nylon / 32% Lycra, Italian Leg Gripper: 80% Polyester / 20% Elastane
 Two Times You



WT6059a
**Compression
 Tri Crop**

Lightweight & Flexible Support

Powerful, lightweight PWX fabric with circular knit 360-degree stretch, reduces muscle movement and prevents fatigue.

Stay Cool

Leveraging a hydrophilic nylon-LYCRA® fibre matrix, SENSOR MESH panelling provides enhanced moisture and air flow management.

Garment Features:

1. Tri racerback crop
2. Ergonomically engineered panelling
3. Powerful, lightweight PWX body
4. Moisture managing SENSOR MESH across shoulders and back

Best For: Mild Weather, Hot Weather
Colours: BLK/GLD
Size Range: XXS, XS, S, M, L, XL
Fabric: 105D PWX Power Mesh, SBR Vent, Sensor Mesh X. 105D PWX Power Mesh: 68% Nylon / 32% Lycra , SBR Vent: 81% Microfibre Polyester / 6% Polyester / 13% Elastane, Sensor Mesh X: 83% Nylon / 17% Elastane

Perform Tri

For stand-out performance across long and short course racing, the Perform Tri range delivers unrivalled aerodynamics and industry-leading ventilation for the seasoned triathlete.



MT5525d / WT6060d
Perform Full Zip Sleeved Trisuit



Men:

Best For: Mild Weather, Hot Weather

Colours: MDN/FMB, BLK/FOM, BLK/SDW

Size Range: XS, S, M, L, XL, XXL

Fabric: 105D PWX Power Mesh, SBR Vent, Sensor Mesh X. Solid SBR Vent: 81% Microfibre Polyester / 6% Polyester / 13% Elastane, Printed SBR Vent: 79% Microfibre Polyester / 6% Polyester / 15% Elastane, SBR Power: 68% Nylon / 32% Elastane, Solid Sensor Mesh X: 83% Nylon / 17% Elastane, Printed Sensor Mesh X: 80% Polyester / 20% Elastane

Garment Features:

1. Sleeved trisuit
2. Ergonomically engineered panelling
3. Powerful, durable SBR POWER lower body
4. Premium Italian SBR VENT upper body
5. Moisture managing SENSOR MESH shoulders
6. Premium Italian-engineered silicone leg grippers
7. High density LD chamois
8. Full length semi-auto lock zip
9. Easily accessible rear pockets

Women:

Best For: Mild Weather, Hot Weather

Colours: BLK/SDW

Size Range: XXS, XS, S, M, L, XL

Fabric: 105D PWX Power Mesh, SBR Vent, Sensor Mesh X. Solid SBR Vent: 81% Microfibre Polyester / 6% Polyester / 13% Elastane, Printed SBR Vent: 79% Microfibre Polyester / 6% Polyester / 15% Elastane, SBR Power: 68% Nylon / 32% Elastane, Solid Sensor Mesh X: 83% Nylon / 17% Elastane, Printed Sensor Mesh X: 80% Polyester / 20% Elastane



MT5526d / WT5533d
Perform Front Zip Trisuit

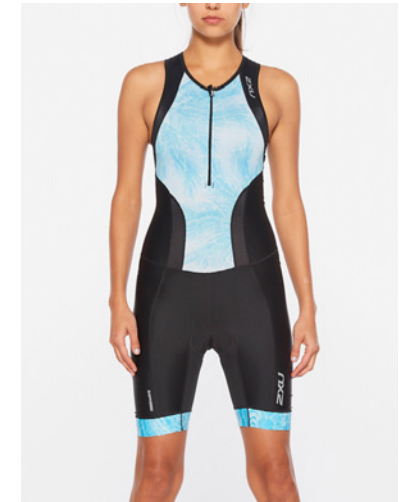

Garment Features:

1. Sleeveless trisuit
2. Ergonomically engineered panelling
3. Powerful, durable SBR POWER lower body
4. Premium Italian SBR VENT upper body
5. Moisture managing SENSOR MESH shoulders
6. Premium Italian-engineered silicone leg grippers
7. High density LD chamois
8. 1/4 length semi-auto lock zip
9. Easily accessible rear pockets

Men:

Best For: Mild Weather, Hot Weather

Colours: MDN/FMB, BLK/FOM, BLK/SDW

Size Range: XS, S, M, L, XL, XXL

Fabric: 105D PWX Power Mesh, SBR Vent, Sensor Mesh X. Solid SBR Vent: 81% Microfibre Polyester / 6% Polyester / 13% Elastane, Printed SBR Vent: 79% Microfibre Polyester / 6% Polyester / 15% Elastane, SBR Power: 68% Nylon / 32% Elastane, Solid Sensor Mesh X: 83% Nylon / 17% Elastane, Printed Sensor Mesh X: 80% Polyester / 20% Elastane

Women:

Best For: Mild Weather, Hot Weather

Colours: BLK/SDW, BLK/AQR

Size Range: XXS, XS, S, M, L, XL

Fabric: 105D PWX Power Mesh, SBR Vent, Sensor Mesh X. Solid SBR Vent: 81% Microfibre Polyester / 6% Polyester / 13% Elastane, Printed SBR Vent: 79% Microfibre Polyester / 6% Polyester / 15% Elastane, SBR Power: 68% Nylon / 32% Elastane, Solid Sensor Mesh X: 83% Nylon / 17% Elastane, Printed Sensor Mesh X: 80% Polyester / 20% Elastane

Powerful & Durable Support

Powerful and durable SBR POWER lower body, reduces muscle movement through legs and core to prevent fatigue.

Unrivalled Aerodynamics

The 3D mesh structure of premium Italian SBR VENT through upper body provides exceptional aerodynamics and is ergonomically engineered to fit to your body like a second skin.

Stay Cool

Leveraging a hydrophilic nylon-LYCRA® fibre matrix, SENSOR MESH panelling provides enhanced moisture and air flow management.

Ld Chamois

Quick-drying long course triathlon chamois fused onto a high density, hydrophobic foam base to manage moisture provides able support for bike while remaining discreet for the run.

Essential Storage

Easily accessible rear pockets provide adequate storage for your race-day essentials.



MT5530a / WT5536a
**Perform
Tri Singlet**

Unrivalled Aerodynamics

The 3D mesh structure of premium Italian SBR VENT through upper body provides exceptional aerodynamics and is ergonomically engineered to fit to your body like a second skin.

Stay Cool

Leveraging a hydrophilic nylon-LYCRA® fibre matrix, SENSOR MESH panelling provides enhanced moisture and air flow management.

Essential Storage

Easily accessible rear pockets provide adequate storage for your race-day essentials.

Men:

Best For: Mild Weather, Hot Weather
Colours: MDN/FMB, BLK/FOM, BLK/SDW
Size Range: XS, S, M, L, XL, XXL
Fabric: SBR Vent, Sensor Mesh X, Solid SBR Vent: 81% Microfibre Polyester / 6% Polyester / 13% Elastane , Printed SBR Vent: 79% Microfibre Polyester / 6% Polyester / 15% Elastane, Solid Sensor Mesh X: 83% Nylon / 17% Elastane, Printed Sensor Mesh X: 80% Polyester / 20% Elastane

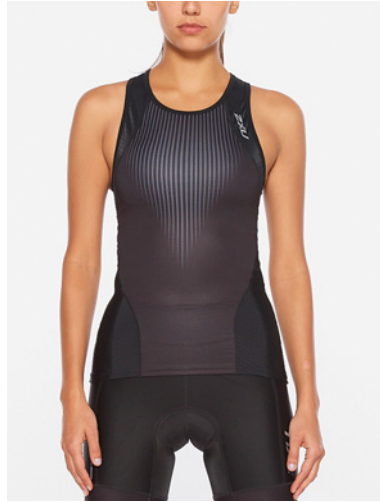

MT5532b
**Perform 9"
Tri Short**

Garment Features:

1. 9" inseam tri short
2. Ergonomically engineered panelling
3. Powerful, durable SBR POWER
4. Premium Italian-engineered silicone leg grippers
5. High density LD chamois
6. Easily accessible rear pockets

Best For: Mild Weather, Hot Weather
Colours: MDN/FBL, BLK/BLK
Size Range: XS, S, M, L, XL, XXL
Fabric: SBR Power, Sensor Mesh X, Italian Leg Gripper. SBR Power: 68% Nylon / 32% Elastane , Sensor Mesh X: 83% Nylon / 17% Elastane, Italian Leg Gripper: 70% Polyester / 30% Elastane

Women:

Best For: Mild Weather, Hot Weather
Colours: BLK/SDW, BLK/AQR
Size Range: XXS, XS, S, M, L, XL
Fabric: SBR Vent, Sensor Mesh X, Solid SBR Vent: 81% Microfibre Polyester / 6% Polyester / 13% Elastane , Printed SBR Vent: 79% Microfibre Polyester / 6% Polyester / 15% Elastane, Solid Sensor Mesh X: 83% Nylon / 17% Elastane, Printed Sensor Mesh X: 80% Polyester / 20% Elastane



MT5531b / WT5539b
**Perform 7"
Tri Short**

Garment Features:

1. 7" inseam tri short
2. Ergonomically engineered panelling
3. Powerful, durable SBR POWER
4. Premium Italian-engineered silicone leg grippers
5. High density LD chamois
6. Easily accessible rear pockets

Best For: Mild Weather, Hot Weather
Colours: MDN/FBL, BLK/BLK
Size Range: XS, S, M, L, XL, XXL
Womens: XXS, XS, S, M, L, XL
Fabric: SBR Power, Sensor Mesh X, Italian Leg Gripper. SBR Power: 68% Nylon / 32% Elastane , Sensor Mesh X: 83% Nylon / 17% Elastane, Italian Leg Gripper: 70% Polyester / 30% Elastane



WT5538b
**Perform 4.5"
Tri Short**

Garment Features:

1. 4.5" inseam tri short
2. Ergonomically engineered panelling
3. Powerful, durable SBR POWER
4. Premium Italian-engineered silicone leg grippers
5. High density LD chamois
6. Easily accessible rear pockets

Best For: Mild Weather, Hot Weather
Colours: BLK/BLK, BLK/AQR
Size Range: XXS, XS, S, M, L, XL
Fabric: SBR Power, Sensor Mesh X, Italian Leg Gripper. SBR Power: 68% Nylon / 32% Elastane , Sensor Mesh X: 83% Nylon / 17% Elastane, Italian Leg Gripper: 70% Polyester / 30% Elastane

Active Tri

Take your race day to a new level with the Active Tri range. Featuring all the tech you need to get you to the finish line, nothing will be holding you back.

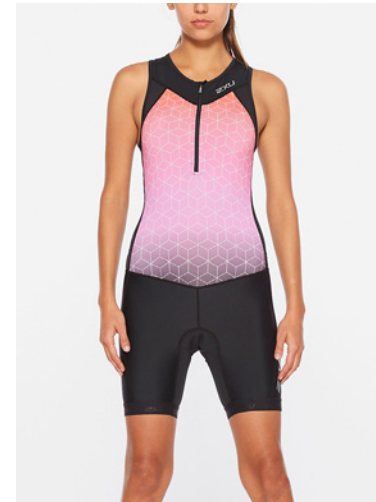

MT5540d / WT5546d

Active Trisuit

Flexible Support

With excellent stretch and recovery memory, SBR SKIN reduces muscle movement through lower body to prevent fatigue whilst SBR SKIN LITE provides lightweight and breathable support to the core.

Stay Cool

Leveraging a hydrophilic nylon-LYCRA® fibre matrix, SENSOR MESH panelling through back provides enhanced moisture and air flow management.

Speedline Chamois

Quick-drying long course triathlon chamois fused onto a high-density, hydrophobic foam base to manage moisture provides ample support for bike while remaining discreet for the run.

Essential Storage

Easily accessible rear pockets provide adequate storage for your race-day essentials.

Garment Features:

1. Sleeveless trisuit
2. Ergonomically engineered panelling
3. Flexible SBR SKIN lower body
4. Lightweight SBR SKIN LITE upper body
5. Moisture managing SENSOR MESH back
6. Y-elastic leg grippers with low-profile silicone
7. Quick-drying LD chamois
8. 1/4 length semi-auto lock zip
9. Easily accessible rear pockets

Best For: Mild Weather, Hot Weather
Colours: MDN/BTN, BLK/BLK
Size Range: XS, S, M, L, XL, XXL
Fabric: SBR Skin, SBR Skin Lite, Sensor Mesh X. SBR Skin: 79% Nylon / 21% Elastane, Solid SBR Skin Lite: 83% Nylon / 17% Elastane, Printed SBR Skin Lite: 83% Polyester / 17% Elastane, Sensor Mesh X: 83% Nylon / 17% Elastane

Best For: Mild Weather, Hot Weather
Colours: BLK/BLK, BLK/STO
Size Range: XXS, XS, S, M, L, XL
Fabric: SBR Skin, SBR Skin Lite, Sensor Mesh X. SBR Skin: 79% Nylon / 21% Elastane, Solid SBR Skin Lite: 83% Nylon / 17% Elastane, Printed SBR Skin Lite: 83% Polyester / 17% Elastane, Sensor Mesh X: 83% Nylon / 17% Elastane



MT5541a / WT5547a
Active Tri Singlet

Flexible Support

SBR SKIN LITE provides lightweight and breathable support to the core.

Stay Cool

Leveraging a hydrophilic nylon-LYCRA® fibre matrix, SENSOR MESH panelling through back provides enhanced moisture and air flow management.

Essential Storage

Easily accessible rear pockets provide adequate storage for your race-day essentials.

Best For: Mild Weather, Hot Weather
Colours: MDN/BTN, BLK/BLK
Size Range: XS, S, M, L, XL, XXL
Fabric: SBR Skin, SBR Skin Lite, Sensor Mesh X. SBR Skin: 79% Nylon / 21% Elastane, Solid SBR Skin Lite: 83% Nylon / 17% Elastane, Printed SBR Skin Lite: 83% Polyester / 17% Elastane, Sensor Mesh X: 83% Nylon / 17% Elastane



Garment Features:

1. Tri singlet
2. Ergonomically engineered panelling
3. Lightweight SBR SKIN LITE upper body
4. Moisture managing SENSOR MESH back
5. 1/4 length semi-auto lock zip
6. Easily accessible rear pockets

Best For: Mild Weather, Hot Weather
Colours: BLK/BLK, BLK/STO
Size Range: XXS, XS, S, M, L, XL
Fabric: SBR Skin, SBR Skin Lite, Sensor Mesh X. SBR Skin: 79% Nylon / 21% Elastane, Solid SBR Skin Lite: 83% Nylon / 17% Elastane, Printed SBR Skin Lite: 83% Polyester / 17% Elastane, Sensor Mesh X: 83% Nylon / 17% Elastane



MT4864b
Active Tri Short

Garment Features:

1. 9" inseam tri short
2. Ergonomically engineered panelling
3. Flexible SBR SKIN
4. Y-elastic leg grippers with low-profile silicone
5. Quick-drying LD chamois
6. Easily accessible rear pockets

Best For: Mild Weather, Hot Weather
Colours: MDN/MDN, BLK/BLK
Size Range: XS, S, M, L, XL, XXL
Fabric: SBR Skin Lite, Leg Gripper. SBR Skin Lite: 83% Nylon / 17% Elastane, Leg Gripper: Nylon / Polyester / Spandex



WT4868b
Active Tri 7" Short

Garment Features:

1. 7" inseam tri short
2. Ergonomically engineered panelling
3. Flexible SBR SKIN
4. Y-elastic leg grippers with low-profile silicone
5. Quick-drying LD chamois
6. Easily accessible rear pockets

Best For: Mild Weather, Hot Weather
Colours: BLK/BLK, BLK/STO
Size Range: XXS, XS, S, M, L, XL
Fabric: SBR Skin Lite, Leg Gripper. SBR Skin Lite: 83% Nylon / 17% Elastane, Leg Gripper: Nylon / Polyester / Spandex



WT4867b
Active Tri 4.5" Short

Garment Features:

1. 4.5" inseam tri short
2. Ergonomically engineered panelling
3. Flexible SBR SKIN
4. Y-elastic leg grippers with low-profile silicone
5. Quick-drying LD chamois
6. Easily accessible rear pockets

Best For: Mild Weather, Hot Weather
Colours: BLK/BLK, BLK/STO
Size Range: XXS, XS, S, M, L, XL
Fabric: SBR Skin Lite, Leg Gripper. SBR Skin Lite: 83% Nylon / 17% Elastane, Leg Gripper: Nylon / Polyester / Spandex



CT5543d
Active Youth
Trisuit

Garment Features:

1. Youth sleeveless trisuit
2. Ergonomically engineered panelling
3. Flexible SBR SKIN lower body
4. Lightweight SBR SKIN LITE upper body
5. Moisture managing SENSOR MESH back
6. Y-elastic leg grippers with low-profile silicone
7. Quick-drying fleece chamois
8. 1/4 length semi-auto lock zip
9. Easily accessible rear pockets

Best For: Mild Weather, Hot Weather
Colours: BLK/SPL, BLK/BLK
Size Range: S, M, L, XL
Fabric: SBR Skin, SBR Skin Lite, Sensor Mesh X. SBR Skin: 79% Nylon / 21% Elastane, Solid SBR Skin Lite: 83% Nylon / 17% Elastane, Printed SBR Skin Lite: 83% Polyester / 17% Elastane, Sensor Mesh X: 83% Nylon / 17% Elastane



CT5544a
Active Youth
Tri Singlet

Garment Features:

1. Youth tri singlet
2. Ergonomically engineered panelling
3. Lightweight SBR SKIN LITE upper body
4. Moisture managing SENSOR MESH back
5. 1/4 length semi-auto lock zip
6. Easily accessible rear pockets

Best For: Mild Weather, Hot Weather
Colours: BLK/BLK
Size Range: S, M, L, XL
Fabric: SBR Skin, SBR Skin Lite, Sensor Mesh X. SBR Skin: 79% Nylon / 21% Elastane, Solid SBR Skin Lite: 83% Nylon / 17% Elastane, Printed SBR Skin Lite: 83% Polyester / 17% Elastane, Sensor Mesh X: 83% Nylon / 17% Elastane



CT4871b
Active Youth
Tri Short

Garment Features:

1. Youth 5" inseam tri short
2. Ergonomically engineered panelling
3. Flexible SBR SKIN
4. Y-elastic leg grippers with low-profile silicone
5. Quick-drying fleece chamois
6. Easily accessible rear pockets

Best For: Mild Weather, Hot Weather
Colours: BLK/BLK
Size Range: S, M, L, XL
Fabric: SBR Skin Lite, Leg Gripper. SBR Skin Lite: 83% Nylon / 17% Elastane, Leg Gripper: Nylon / Polyester / Spandex

Propel Pro

The Propel Pro Wetsuit features the latest in wetsuit technology and design innovation to ensure natural swimmers have ultimate flexibility and minimal water resistance for their best time yet.

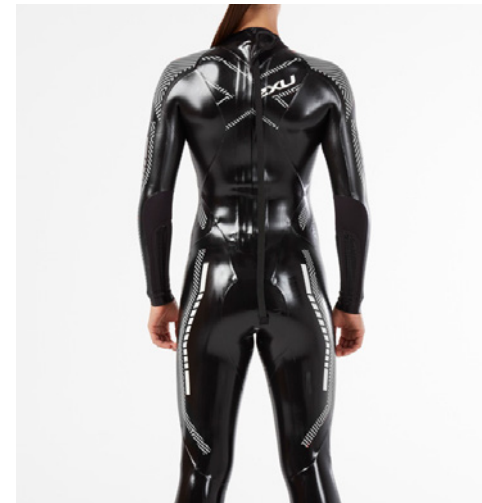

MW5124c / WW5125c

Propel:Pro Wetsuit

Ultimate Flexibility

Premium Japanese Yamamoto 45 Cell seamless shoulder and arm neoprene provides ultimate flexibility.

Minimal Water Resistance

Nano Super Composite Skin (SCS) hydrodynamic coating reduces surface drag for more speed and improved durability whilst Velocity Strakes provide hydrodynamic stability in choppy water and assist you swim in a straight line.

Optimal Bouyancy

Premium Japanese Yamamoto 39 Cell neoprene is bouyant but still flexible and varies in thickness throughout the core of the wetsuit, moving your centre of bouyancy lower, preventing sinky legs and putting you in perfect horizontal swimming position.

Enhanced Power & Efficiency

Embossed concave water entrapment zone on arm sleeve, enhances power and feel of water whilst the floating zip panel provides unrestricted movement for improved distance per stroke.

Improved Rotation

Rollbar technology ensures less bouyancy on perimeter of wetsuit, allowing snappier side-to-side rotation and eliminating dead spots in your freestyle.

Inner Comfort & Support

Our neck panel eliminates seams to improve comfort and reduce chafing whilst the often-overlooked internal liner is engineered for 520% stretch to ensure comfort and low absorption.

Garment Features:

1. Full tri wetsuit
2. Nano SCS hydrodynamic coating
3. Shoulder and arm premium Japanese Yamamoto 45 Cell flexible neoprene
4. Body premium Japanese Yamamoto 39 Cell bouyant neoprene
5. Arm sleeve embossed concave water entrapment zone
6. Chest seamless bouyancy inserts
7. Velocity Strakes on front body
8. Floating zip panel
9. Core Intermediate Stretch Zone (ISZ) panels
10. Rollbar technology
11. Lower leg propulsion panel
12. Quick release ankle Transition Panel
13. 520% internal stretch lining
14. Two-year warranty

Men:

Best For: Cold Weather, Wet Weather, Mild Weather, Hot Weather
Colours: BLK/SIL
Size Range: XS, S, ST, SM, M, MT, MS, L, LT, XL, XLT, XXL, XXXL
Fabric: Neoprene 100% Sponge Rubber Nylon Laminated

Women:

Best For: Cold Weather, Wet Weather, Mild Weather, Hot Weather
Colours: BLK/SIL
Size Range: XS, S, ST, SM, M, MT, MS, L, LT, XL, XLT, XXL, XXXL
Fabric: Neoprene 100% Sponge Rubber Nylon Laminated

Propel 2

Winner of Triathlete Magazine Buyer's Guide 'Best In Class', the Propel P:2 Wetsuit is loaded with world-leading technology to provide the progressive swimmer with optimal buoyancy and flexibility to power to the finish line.

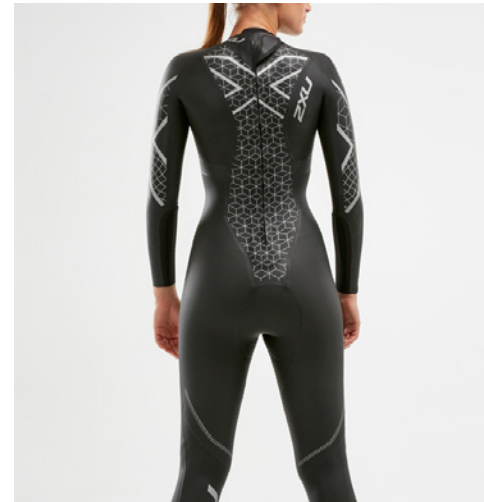

MW4990c / WW4993c

Propel:2 Wetsuit

Ultimate Buoyancy & Flexibility

Premium Japanese Yamamoto 39 Cell neoprene is buoyant but still flexible and varies in thickness throughout the body of the wetsuit, moving your centre of buoyancy lower, preventing sinky legs and putting you in perfect horizontal swimming position.

Reduced Water Resistance

Super Composite Skin (SCS) hydrodynamic coating reduces surface drag for more speed.

Enhanced Power & Efficiency

Embossed concave water entrapment zone on arm sleeve, enhances power and feel of water whilst the floating zip panel increases movement for improved distance per stroke.

Improved Rotation

Rollbar technology ensures less buoyancy on perimeter of wetsuit, allowing snappier side-to-side rotation and eliminating dead spots in your freestyle.

Inner Comfort & Support

Our neck panel eliminates seams to improve comfort and reduce chafing whilst the often-overlooked internal liner is engineered for 520% stretch to ensure comfort and low absorption.=

Garment Features:

1. Full tri wetsuit
2. SCS hydrodynamic coating
3. Full body premium Japanese Yamamoto 39 Cell bouyant and flexible neoprene
4. Arm sleeve embossed concave water entrapment zone
5. Floating zip panel
6. Core Intermediate Stretch Zone (ISZ) panels
7. Rollbar technology
8. Lower leg propulsion panel
9. Quick release ankle Transition Panel
10. 520% internal stretch lining
11. Two-year warranty

Men:

Best For: Cold Weather, Wet Weather, Mild Weather, Hot Weather
Colours: BLK/XGO, BLK/FZZ
Size Range: XS, S, ST, SM, M, MT, MS, L, LT, XL, XLT, XXL, XXXL
Fabric: Neoprene 100% Sponge Rubber Nylon Laminated

Women:

Best For: Cold Weather, Wet Weather, Mild Weather, Hot Weather
Colours: BLK/XGO
Size Range: XS, S, ST, SM, M, MT, MS, L, LT, XL, XLT, XXL, XXXL
Fabric: Neoprene 100% Sponge Rubber Nylon Laminated

Propel 1

The Propel P:1 Wetsuit is an all-round performer equipped with many of the technical features to give aspiring swimmers a winning edge.

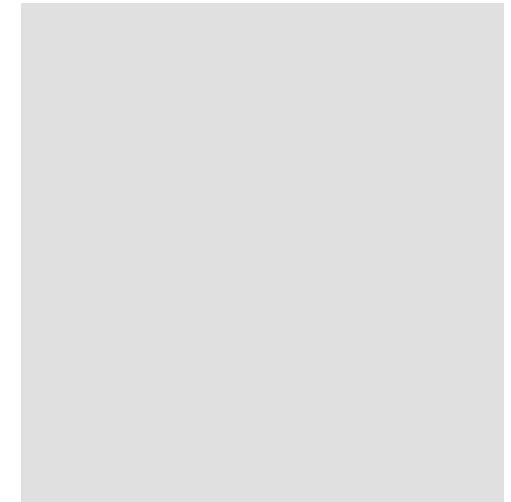
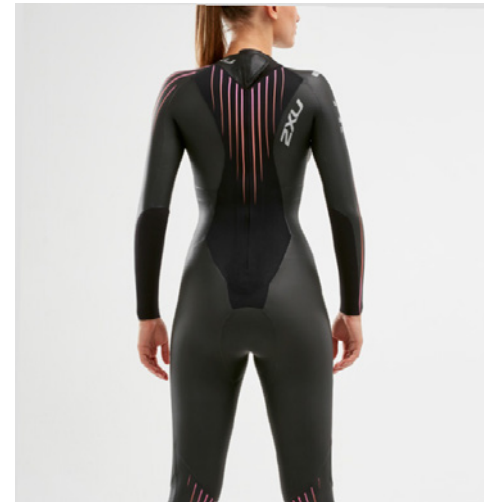

MW4991c / WW4994c

Propel:1 Wetsuit

Garment Features:

1. Full tri wetsuit
2. SCS hydrodynamic coating
3. Front body premium Japanese Yamamoto 39 Cell bouyant and flexible neoprene
4. Back panel premium Japanese Yamamoto 39 Cell nylon laminated durable neoprene
5. Floating zip panel
6. Rollbar technology
7. Lower leg propulsion panel
8. Quick release ankle Transition Panel
9. 520% internal stretch lining
10. Two-year warranty

Men:

Best For: Cold Weather, Wet Weather, Mild Weather, Hot Weather
Colours: BLK/SSW, BLK/BRE
Size Range: XS, S, ST, SM, M, MT, MS, L, LT, XL, XLT, XXL, XXXL
Fabric: Neoprene 100% Sponge Rubber Nylon Laminated

Women:

Best For: Cold Weather, Wet Weather, Mild Weather, Hot Weather
Colours: BLK/SOM
Size Range: XS, S, ST, SM, M, MT, MS, L, LT, XL, XLT, XXL, XXXL
Fabric: Neoprene 100% Sponge Rubber Nylon Laminated

CW6569c

Propel: Youth Wetsuit

Garment Features:

1. Full youth wetsuit
2. Premium Japanese Yamamoto 39 Cell bouyant and flexible neoprene
3. 520% internal stretch lining
4. Two-year warranty

Best For: Cold Weather, Wet Weather, Mild Weather, Hot Weather
Colours: BLK/OAS
Size Range: S, M, L
Fabric: Neoprene 100% Sponge Rubber Nylon Laminated

Bouyant & Flexible

Premium Japanese Yamamoto 39 Cell neoprene is bouyant but still flexible and varies in thickness throughout the body of the wetsuit, moving your centre of bouyancy lower, preventing sinky legs and putting you in perfect horizontal swimming position.

Reduced Water Resistance

Super Composite Skin (SCS) hydrodynamic coating reduces surface drag for more speed.

Enhanced Efficiency

Floating zip panel increases movement for improved distance per stroke.

Improved Rotation

Rollbar technology ensures less bouyancy on perimeter of wetsuit, allowing snappier side-to-side rotation and eliminating dead spots in your freestyle.

Inner Comfort & Support

Often-overlooked internal liner is engineered for 520% stretch to ensure comfort and low absorption.



MW5477c / WW5478c
SWIMRUN: PRO
WETSUIT

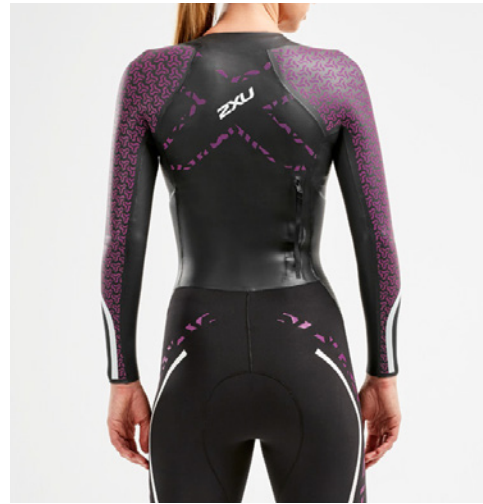

MW5479c / WW5480c
SWIMRUN: 1
WETSUIT



Ultimate Flexibility

Premium Japanese Yamamoto 1.5mm shoulder and underarm neoprene ensure you get most out of your strokes in water whilst flexible hip and pelvis panels allow you to run freely.

Reduced Water Resistance

Super Composite Skin (SCS) hydrodynamic coating reduces surface drag for more speed.

Maximum Bouyancy

Premium Japanese Yamamoto neoprene is as thick as 8mm in upper legs to ensure you have the bouyancy to carry what you need and maintain a horizontal swimming position without sinking legs.

Improved Rotation

Rollbar technology ensures less bouyancy on perimeter of wetsuit, allowing snappier side-to-side rotation and eliminating dead spots in your freestyle.

Comfort & Support

Front zip provides increased ventilation without having to remove during run whilst the often-overlooked internal liner is engineered for 520% stretch to ensure comfort and low absorption.

Essential Storage

Internal front and zipped rear pocket provides adequate storage for your race-day essentials whilst a front whistle pocket ensures safety.

Garment Features:

1. SwimRun wetsuit
2. SCS hydrodynamic coating
3. Full body premium Japanese Yamamoto bouyant and flexible neoprene
4. Front full body zipper
5. Hyperflex 1.5mm shoulder and underarm panels
6. Rollbar technology
7. Flexible hip and pelvis panels
8. 8mm upper leg bouyancy inserts
9. Abrasion resistant rear double-sided nylon panel
10. Internal front and zip rear pockets
11. Whistle for safety
12. 520% internal stretch lining

	Men:	Women:
Best For:	Cold Weather, Wet Weather, Mild Weather, Hot Weather	Cold Weather, Wet Weather, Mild Weather, Hot Weather
Colours:	BLK/FSC	BLK/WYG
Size Range:	S, M, L, XL, XXL	XS, S, M, L, XL
Fabric:	Neoprene 100% Sponge Rubber Nylon Laminated	Neoprene 100% Sponge Rubber Nylon Laminated

Bouyant & Durable

Premium Japanese Yamamoto Limestone neoprene is bouyant and durable to ensure you get most out of your strokes in water whilst remaining tough for climbing out of it.

Flexible

Hyperflex 1.5mm shoulder and underarm panels provide unrivalled swim flexibility and hip and pelvis panels are designed for freedom of movement on the run.

Improved Rotation

Rollbar technology ensures less bouyancy on perimeter of wetsuit, allowing snappier side-to-side rotation and eliminating dead spots in your freestyle.

Comfort & Support

Front zip provides increased ventilation without having to remove during run whilst the often-overlooked internal liner is engineered for stretch to ensure comfort and low absorption.

Essential Storage

Zipped rear pocket provides adequate storage for your race-day essentials.

Garment Features:

1. SwimRun wetsuit
2. Full body premium Japanese Yamamoto bouyant and durable Limestone neoprene
3. Front full body zipper
4. Hyperflex 1.5mm shoulder and underarm panels
5. Rollbar technology
6. Flexible hip and pelvis panels
7. Abrasion resistant
8. Rear zip pocket

	Men:	Women:
Best For:	Cold Weather, Wet Weather, Mild Weather, Hot Weather	Cold Weather, Wet Weather, Mild Weather, Hot Weather
Colours:	BLK/BSG	BLK/ARG
Size Range:	S, M, L, XL, XXL	XS, S, M, L, XL
Fabric:	Neoprene 100% Sponge Rubber Nylon Laminated	Neoprene 100% Sponge Rubber Nylon Laminated

BREED

RECOVER

RECOVER FASTER

Recovery is training. Most of the time it is overlooked but it forms a vital part in preparing for the next race or session. Whether in transit or resting on the couch, there is always a time for the body to be working.

RECOVERY

GO-TO-MARKET

RECOVERY IS THE MOST IMPORTANT PILLAR OF THE ATHLETE CYCLE. OUR PRODUCT, THROUGH INNOVATION AND PRACTICALITY, ALLOWS THE ATHLETE TO BE READY TO GO FOR THEIR NEXT SESSION.

CONSUMER PROFILE

Athletes want to be working when they are resting. The demands of today's high-level athlete is such that time between training and races has become shorter and shorter. Athletes are seeking out new ways to speed up recovery, making each day less taxing on their bodies.

COLLECTIONS GUIDE

POWER

Work extra hard while recovering from the hardest of sessions.

REFRESH

Everyday recovery to keep the body fresh.

FLIGHT

Protection from long and short haul flights.



GOAL

Utilise our renowned recovery compression to drive other category growth. Advance recovery technology and innovation.

NOW

Be the home of recovery, in-store, at events and online. Be known for recovery and the versatility of the recovery range across sports.

MARKETING SUPPORT

Print Advertising
Digital Advertising
Social Media
Trade Marketing
Visual Merchandising
Seeding Packs
Ambassador Marketing
Athlete Marketing
Community and Event Marketing

Power Recovery

Featuring graduated stamping technology and powerful over-foot compression, the Power Recovery Compression Tights will help you return to your peak in the fastest possible time.



MA4417b / WA4418b
Power Recovery
Compression Tights

Graduated Stamping

Leveraging the learnings of MCS technology, graduated stamping on the external surface precisely controls the compression profile, ensuring maximum boosting of blood flow for faster recovery.

Over-Foot Stirrup

Starting at the ball of the foot, an over-foot stirrup provides targeted compression relief from the furthest extremity for entire lower body relief.

Graduated Compression

Extra firm PWX fabric with circular knit 360-degree stretch, reduces muscle movement whilst a graduated compression profile boosts blood flow to muscles speeding up recovery.

Designed To Be Layered

Flat jacquard elastic waistband delivers a smooth, secure feel and allows for easy layering beneath shorts or joggers if required.

Quick-Drying

High quality, durable, moisture-wicking yarns outlast the competition and keep the skin cool and dry.

Garment Features:

1. Full length compression tight
2. PWX highly powerful and flexible compression fabric
3. Graduated compression for improved circulation
4. External graduated stamping
5. Over-foot stirrup
6. Flat jacquard elastic waistband for easy layering
7. Signature X logo on calf
8. Flatlock seams to reduce chafe

Men:

Best For: Cold Weather, Mild Weather, Hot Weather
Colours: BLK/NRO
Size Range: XXS, XS, S, ST, M, MT, L, LT, XL, XLT, XXL, XXLT, XXXL
Rise: Regular
Waistband: 5cm brushed inward facing elastic
Fabric: PWX 105D. 65% Nylon, 35% Lycra

Women:

Best For: Cold Weather, Mild Weather, Hot Weather
Colours: BLK/NRO
Size Range: XXS, XS, XST, S, ST, M, MT, L, LT, XL, XXL
Rise: Regular
Waistband: 5cm brushed inward facing elastic
Fabric: PWX 105D. 65% Nylon, 35% Lycra

Refresh Recovery

With extra-firm graduated compression to stabilise muscles and promote blood flow for faster recovery, the Refresh Recovery Compression Tights guarantee fresher legs after intense training or competition.



MA4419b / WA4420b
Refresh Recovery Compression Tights

Graduated Compression

Extra firm PWX fabric with circular knit 360-degree stretch, reduces muscle movement whilst a graduated compression profile boosts blood flow to muscles speeding up recovery.

Designed To Be Layered

Flat jacquard elastic waistband delivers a smooth, secure feel and allows for easy layering beneath shorts or joggers if required.

Quick-Drying

High quality, durable, moisture-wicking yarns outlast the competition and keep the skin cool and dry.

Garment Features:

1. Full length compression tight
2. PWX highly powerful and flexible compression fabric
3. Graduated compression for improved circulation
4. Flat jacquard elastic waistband for easy layering
5. Signature X logo on thigh
6. Flatlock seams to reduce chafe

Men:

Best For: Cold Weather, Mild Weather, Hot Weather
Colours: BLK/NRO
Size Range: XXS, XS, S, ST, M, MT, L, LT, XL, XLT, XXL, XXLT, XXXL
Rise: Regular
Waistband: 5cm 2XU jacquard elastic
Fabric: PWX 105D. 65% Nylon, 35% Lycra

Women:

Best For: Cold Weather, Mild Weather, Hot Weather
Colours: BLK/NRO
Size Range: XXS, XS, XST, S, ST, M, MT, L, LT, XL, XXL
Rise: Regular
Waistband: 5cm 2XU jacquard elastic
Fabric: PWX 105D. 65% Nylon, 35% Lycra



UA4427a
Recovery Flex
Arm Sleeves

Garment Features:

1. Compression arm sleeves
2. Support for the forearms, elbows, and biceps
3. Graduated fit to promote increased circulation for a faster recovery
4. Flexible articulated elbow zone for greater comfort
5. Low-profile design that can be easily pulled on or off as required

Best For: Cold Weather, Mild Weather, Hot Weather
Colours: BLK/NRO
Size Range: XS, XS, S, M, L, XL, XXL
Fabric: 80% Nylon, 20% Lycra



UA4425b
Recovery Flex
Leg Sleeves

Garment Features:

1. Compression leg sleeves
2. Support to the quadricep, hamstring and calf muscles
3. Graduated fit to promote increased circulation for faster recovery
4. Flexible articulated knee zone for greater comfort
5. Low-profile design that can be easily pulled on or off as required

Best For: Cold Weather, Mild Weather, Hot Weather
Colours: BLK/NRO
Size Range: XS, XS, S, M, L, XL, XXL
Fabric: 80% Nylon, 20% Lycra



UA5691e
Compression
Socks For Recovery

Garment Features:

1. Full length sock
2. Graduated fit to promote blood flow for faster muscle repair and recovery
3. Anatomical design
4. Padded zones to the heels and balls of the feet for maximum comfort
5. Seamless linked toe cage for greater comfort
6. Vented toe panel for breathability

Best For: Cold Weather, Mild Weather, Hot Weather
Colours: BLK/GRY
Size Range: S, M1, M2, L1, L2, XL
Fabric: 80% Micro Fibre Nylon, 20% Elastane

Maternity

Stay active and feel supported throughout your pregnancy. Designed specifically for growing bellies, the Prenatal Compression range boosts blood flow to alleviate tired and swollen legs, while a breathable seam-free stomach panel grows with you. After birth, the Postnatal Compression range provides abdominal protection and lower back support to ease recovery.



WA3595b
Prenatal
Active Tights

Seamless Stomach Panel

Non-compression yet supportive seam-free stomach panel grows with you during your pregnancy.

Lightweight & Flexible Support

Powerful, lightweight PWX fabric with circular knit 360-degree stretch and Power Mesh reduces muscle movement and provide support to the lower back.

Graduated Compression

Firm graduated compression to assist circulation and reduce swelling in the ankles and feet.

Quick-Drying

High quality, durable, moisture-wicking yarns outlast the competition and keep the skin cool and dry.

Garment Features:

1. Full length compression tight
2. PWX highly powerful, lightweight and flexible compression fabric
3. Non-compression, breathable, seamless stomach panel
4. Power mesh supportive lower back panel
5. Graduated compression to assist circulation and reduce swelling in the ankles and feet
6. Signature tonal X logos on thigh and calf
7. Flatlock seams to reduce chafe
8. Recommended from 26 weeks+

Best For:	Cold Weather, Mild Weather
Colours:	BLK/NRO
Size Range:	XS, S, M, L, XL
Rise:	Under Bust
Waistband:	4cm covered elastic
Fabric:	Front - PWX 70D Back - PWX 160D Gusset - PWX 105D 72% Nylon, 28% Lycra



WA3598b
Postnatal
Active Tights

Seamless Stomach Panel

Non-compression yet supportive seam-free stomach panel works to assist abdominal muscle recovery.

Lightweight & Flexible Support

Powerful, lightweight PWX fabric with circular knit 360-degree stretch and Power Mesh reduces muscle movement and provide support to the lower back.

Graduated Compression

Firm graduated compression to assist circulation and reduce swelling in the ankles and feet.

Quick-Drying

High quality, durable, moisture-wicking yarns outlast the competition and keep the skin cool and dry.

Garment Features:

1. Full length compression tight
2. PWX highly powerful, lightweight and flexible compression fabric
3. Non-compression, breathable, seamless stomach panel
4. Power mesh supportive lower back panel
5. Graduated compression to assist circulation and reduce swelling in the ankles and feet
6. Signature tonal X logos on thigh and calf
7. Flatlock seams to reduce chafe

Best For:	Cold Weather, Mild Weather
Colours:	BLK/NRO
Size Range:	XS, S, M, L, XL
Rise:	Under Bust
Waistband:	4cm covered elastic
Fabric:	Front - PWX 70D Back - PWX 160D Gusset - PWX 105D 72% Nylon, 28% Lycra



WA3597b
Prenatal
Active Shorts

Seamless Stomach Panel

Non-compression yet supportive seam-free stomach panel grows with you during your pregnancy.

Lightweight & Flexible Support

Powerful, lightweight PWX fabric with circular knit 360-degree stretch and Power Mesh reduces muscle movement and provide support to the lower back.

Graduated Compression

Firm graduated compression to assist circulation and reduce swelling in the ankles and feet.

Quick-Drying

High quality, durable, moisture-wicking yarns outlast the competition and keep the skin cool and dry.

Garment Features:

1. Compression short
2. PWX highly powerful, lightweight and flexible compression fabric
3. Non-compression, breathable, seamless stomach panel
4. Power mesh supportive lower back panel
5. Signature tonal X logos on thigh
6. Flatlock seams to reduce chafe
7. Recommended from 26 weeks+

Best For:	Cold Weather, Mild Weather
Colours:	BLK/NRO
Size Range:	XS, S, M, L, XL
Rise:	Under Bust
Waistband:	4cm covered elastic
Fabric:	Front - PWX 70D Back - PWX 160D Gusset - PWX 105D 72% Nylon, 28% Lycra



WA3600b
Postnatal
Active Shorts

Seamless Stomach Panel

Non-compression yet supportive seam-free stomach panel works to assist abdominal muscle recovery.

Lightweight & Flexible Support

Powerful, lightweight PWX fabric with circular knit 360-degree stretch and Power Mesh reduces muscle movement and provide support to the lower back.

Graduated Compression

Firm graduated compression to assist circulation and reduce swelling in the ankles and feet.

Quick-Drying

High quality, durable, moisture-wicking yarns outlast the competition and keep the skin cool and dry.

Garment Features:

1. Compression short
2. 2PWX highly powerful, lightweight and flexible compression fabric
3. Non-compression, breathable, seamless stomach panel
4. Power mesh supportive lower back panel
5. Signature tonal X logos on thigh
6. Flatlock seams to reduce chafe

Best For:	Cold Weather, Mild Weather
Colours:	BLK/NRO
Size Range:	XS, S, M, L, XL
Rise:	Under Bust
Waistband:	4cm covered elastic
Fabric:	Front - PWX 70D Back - PWX 160D Gusset - PWX 105D 72% Nylon, 28% Lycra

TRANSIT

GO-TO-MARKET

TRANSIT BETWEEN SESSIONS, BETWEEN RACES, BETWEEN THE GYM AND WORK WITH DURABILITY AND COMFORT.

CONSUMER PROFILE

Athletes want the same performance from their everyday wear as they get from their performance gear, they want durability, they want comfort. They like travelling in style and they don't mind showcasing that they are an athlete.

COLLECTIONS GUIDE

UTILITY

Durability for even the toughest trips.

COMMUTE

Everyday to and from apparel.

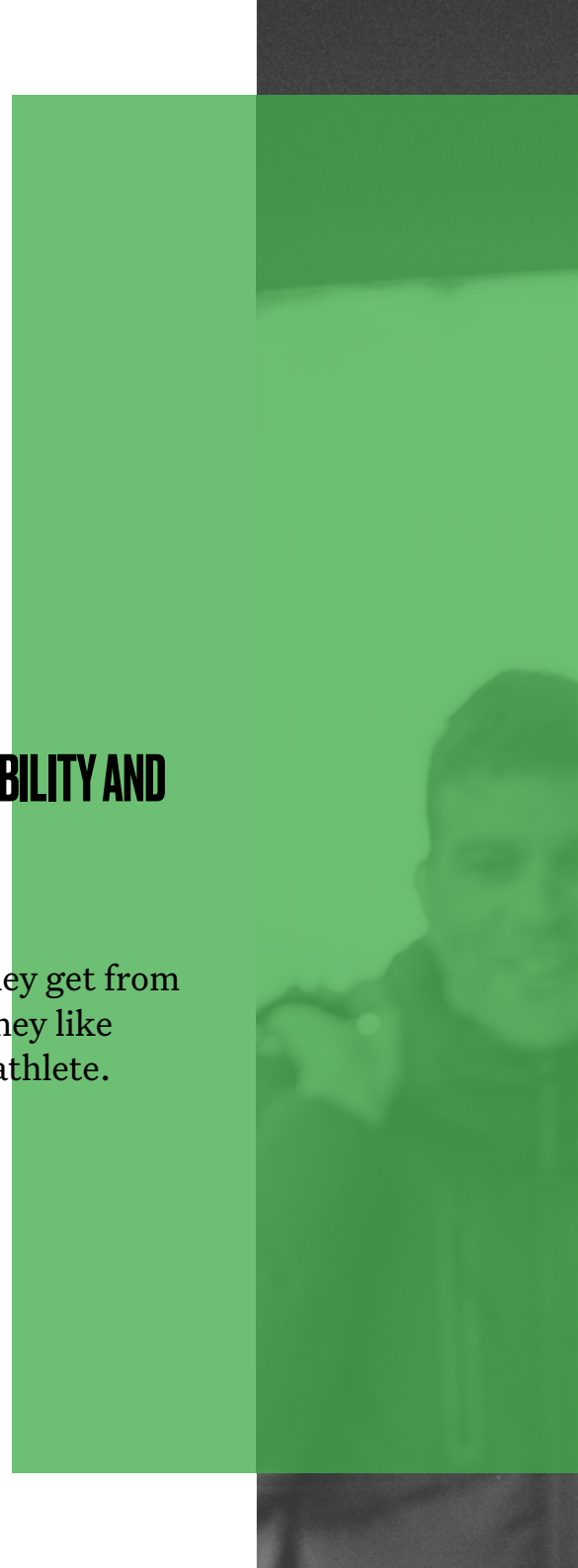

GOAL Transit is the most sought-after travel wear in the market. It's comfort, durability and on-trend design allows the travelling athlete to arrive in style.

NOW Focus on hero products, develop the range as everyday comfort and classics yet incorporating performance elements.

MARKETING SUPPORT

Print Advertising
Digital Advertising
Social Media
Trade Marketing
Visual Merchandising
Seeding Packs
Ambassador Marketing
Athlete Marketing

Utility

Combat cold and wet conditions with the Utility Insulation range. Featuring lightweight 3M™ Thinsulate Featherless Insulation for ultimate warmth, and environmentally responsible C6 DWR treatment to withstand rain and showers, you'll stay warm and dry to and from training.



MR6265a
Utility Insulation Jacket

Garment Features:

1. Full zip jacket
2. Double-weave downproof water-resistant shell
3. Environmentally responsible C6 DWR surface treatment
4. 3M™ Thinsulate™ Featherless Insulation
5. Removable hood to customise your style
6. Thermo-reflective inner back panel
7. Fleece-lined front side zip pockets
8. Waterproof chest zip pocket
9. Internal pocket

Best For: Cold Weather, Wet Weather
Colours: BLK/BLK, CRH/BLK
Size Range: XS, S, M, L, XL, XXL
Fabric: Outer Shell: 100% Polyester
 Lining: 100% Nylon
 Thermo Reflective Lining: 100% Polyester
 Insulation: 100% Polyester



WR6284a
Utility Insulation Longline Jacket

Garment Features:

1. Full zip longline jacket
2. Water-resistant downproof shell
3. 3M™ Thinsulate™ Featherless Insulation
4. Removable hood to style your way
5. Thermo-reflective inner back panel
6. Fleece-lined front side zip pockets
7. Internal pocket

Best For: Cold Weather, Wet Weather
Colours: BLK/BLK, WHT/BLK
Size Range: XXS, XS, S, M, L, XL
Fabric: Outer Shell: 100% Polyester
 Lining: 100% Nylon
 Thermo Reflective Lining: 100% Polyester
 Insulation: 100% Polyester



WR6283a
Utility Insulation Jacket

Garment Features:

1. Full zip jacket
2. Water-resistant downproof shell
3. 3M™ Thinsulate™ Featherless Insulation
4. Removable hood to style your way
5. Thermo-reflective inner back panel
6. Fleece-lined front side zip pockets
7. Internal pocket

Best For: Cold Weather, Wet Weather
Colours: BLK/BLK, WHT/BLK
Size Range: XXS, XS, S, M, L, XL
Fabric: Outer Shell: 100% Polyester
 Lining: 100% Nylon
 Thermo Reflective Lining: 100% Polyester
 Insulation: 100% Polyester

Commute

Experience performance from the street to the gym with the Commute range. Featuring soft, stretchy, double-knit fleece, the Commute range is perfect for a quick winter workout or a day on the move.



MR6268a / WR6285a

Commute Full Zip Hoodie

Stay Warm

Double-knit fleece construction creates small air pockets that trap your body heat in.

Total Comfort

With a streamlined fit, the soft & stretchy fleece features ribbed cuffs and hem detailing and moisture-wicking properties for all day comfort.

Essential Storage

Front pockets to store your essentials.

Garment Features:

1. Full zip hooded jacket
2. Double-knit moisture-wicking fleece
3. Front pockets
4. Bonded logos, bartack and stripe detailing
5. Articulated sleeves
6. Ribbed cuffs and hem

Men:

Best For: Cold Weather

Colours: BLK/BLK, CHM/BLK

Size Range: XS, S, M, L, XL, XXL

Fabric: 80% Cotton 20% Polyester

Women:

Best For: Cold Weather

Colours: BLK/BLK, NVM/BLK

Size Range: XXS, XS, S, M, L, XL

Fabric: 80% Cotton 20% Polyester

MR6269a / WR6287a

Commute Crew

Stay Warm

Double-knit fleece construction creates small air pockets that trap your body heat in.

Total Comfort

With a streamlined fit, the soft & stretchy fleece features ribbed cuffs and hem detailing and moisture-wicking properties for all day comfort.

Essential Storage

Front pockets to store your essentials.

Garment Features:

1. Set-in long sleeve crew
2. Double-knit moisture-wicking fleece
3. Front pockets
4. Bonded logos, bartack and stripe detailing
5. Ribbed neckband, cuffs and hem

Men:

Best For: Cold Weather

Colours: BLK/BLK, CHM/BLK

Size Range: XS, S, M, L, XL, XXL

Fabric: 80% Cotton 20% Polyester

Women:

Best For: Cold Weather

Colours: BLK/BLK, NVM/BLK

Size Range: XXS, XS, S, M, L, XL

Fabric: 80% Cotton 20% Polyester



MR6366b
Commute
9" Shorts

Stay Dry

Double-knit breathable, moisture-wicking fleece keeps you dry.

Total Comfort

With a streamlined, modern fit and adjustable drawcord waistband, the soft, stretchy fleece is breathable and has moisture-wicking properties for all day comfort.

Essential Storage

Slanted side pockets and back pocket to store your essentials.

Garment Features:

1. 9" inseam, fleece short
2. Double-knit breathable, moisture-wicking fleece
3. Drawcord waistband
4. Slanted side pockets
5. Back pocket
6. Bonded logos and bartack detailing

Best For: Mild Weather

Colours: BLK/BLK, CHM/BLK
Size Range: XS, S, M, L, XL, XXL
Fabric: 80% Cotton 20% Polyester



MR6273b / WR6291b
Commute
Trackpant

Stay Warm

Double-knit fleece construction creates small air pockets that trap the body heat in.

Total Comfort

With a streamlined, modern fit and adjustable waistband for a secure fit, the soft, stretchy fleece has ribbed cuff detailing for secure fit and moisture-wicking properties for all day comfort.

Essential Storage

Back pocket and side pockets to store your essentials.

Men:

Best For: Cold Weather

Colours: BLK/BLK, CHM/BLK
Size Range: XS, S, M, L, XL, XXL
Fabric: 80% Cotton 20% Polyester



Garment Features:

1. Tapered trackpant
2. Double-knit moisture-wicking fleece
3. Drawcord waistband
4. Side pockets, one with zip
5. Back pocket
6. Bonded logos, bartack and stripe detailing
7. Ribbed cuffs

Women:

Best For: Cold Weather

Colours: BLK/BLK, NVM/BLK
Size Range: XXS, XS, S, M, L, XL
Fabric: 80% Cotton 20% Polyester

Flight

Arrive ready to hit the ground running with the Flight collection. Made from a cotton-blend brushed fabric for ultimate comfort, and featuring graduated compression for boosted circulation & reduced swelling in the air, you'll land fresh and ready for the day ahead.



MA5642b / WA5643b

Flight Compression Tights

Graduated Compression

Maintains healthy circulation, minimising swelling and stiffness on long-haul flights.

Improved Circulation

Boosted venous return and lymphatic drainage lowers the risk of DVT and swelling.

Ultimate Comfort

Cotton-blend brushed fabric is soft against the skin and ensures body maintains a comfortable temperature in the air.

Designed To Be Layered

Flat jacquard elastic waistband delivers a smooth, secure feel and allows for easy layering beneath shorts or joggers if required.



UA5689e

Flight Compression Socks Ultra Light

Garment Features:

1. Full length sock
2. Light brushed cotton blend compression fabric
3. Graduated compression to help reduce swelling and risk of DVT
4. Anatomical design
5. 1.25mm ultralight cushioning for easy fit in shoes
6. Seamless linked toe cage for greater comfort
7. Vented toe panel for breathability

Best For: Mild Weather, Hot Weather

Colours: BLK/BLK

Size Range: XS, S, M, L, XL

Fabric: Nylon 73%, Lycra 15%, Cotton 12%



UA5688e

Flight Compression Socks

Garment Features:

1. Full length sock
2. Light brushed cotton blend compression fabric
3. Graduated compression to help reduce swelling and risk of DVT
4. Anatomical design
5. 2.5mm light cushioning for maximum comfort
6. Seamless linked toe cage for greater comfort
7. Vented toe panel for breathability

Best For: Cold Weather, Mild Weather

Colours: BLK/BLK

Size Range: XS, S, M, L, XL

Fabric: Nylon 73%, Lycra 15%, Cotton 12%

2XU

ACCESSO

DRIES

COMPLETE THE SYSTEM

Enhance your performance even further with a range of accessories across socks, headwear, bags and more that allow the athlete to complete the system.

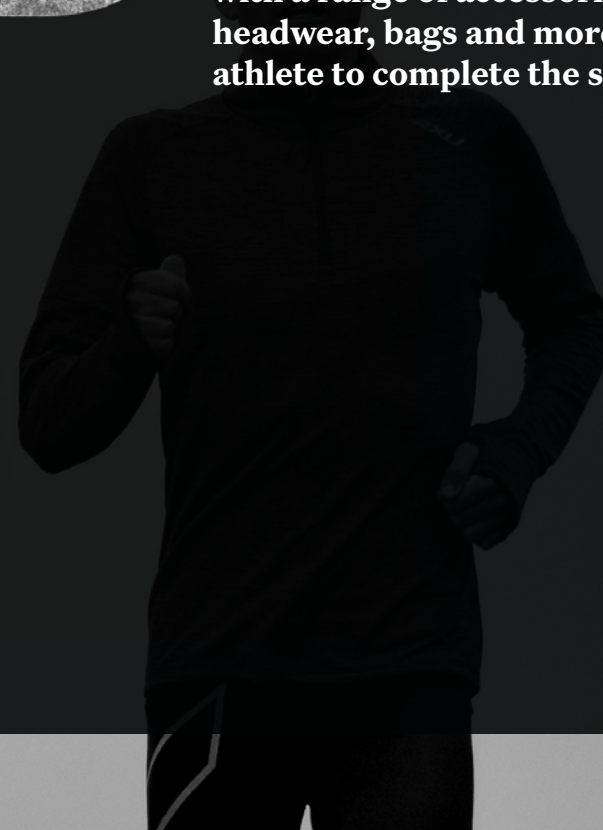
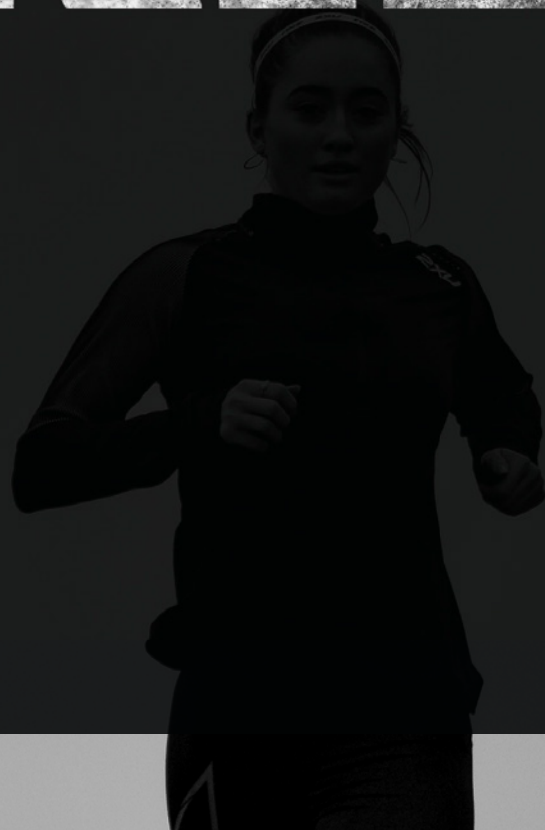



UA5041e
Vectr Ultralight No Show Socks

Garment Features:

1. No show sock
2. X-LOCK technology feature
3. Anatomical design
4. 1.25mm ultralight cushioning
5. Anti-abrasion seamless toe construction
6. Zoned mesh ventilation for increased breathability

Recommended Activities Hot Weather

Colours: BLK/TTM, TTM/BLK, WHT/GRY, ECH/MDN, ALP/BLK, CBY/BLK

Size Range: S, M, L, XL

Fabric: 45% Olefin 43% Nylon 12% Lycra



UA5046e
Vectr Ultralight 1/4 Crew Sock

Garment Features:

1. 1/4 crew sock
2. X-LOCK technology feature
3. Anatomical design
4. 1.25mm ultralight cushioning
5. Anti-abrasion seamless toe construction
6. Zoned mesh ventilation for increased breathability

Best For: Hot Weather

Colours: BLK/TTM, WHT/GRY, ECH/MDN, ALP/BLK

Size Range: S, M, L, XL

Fabric: 45% Olefin 43% Nylon 12% Lycra



UA5051e
Vectr Ultralight Crew Socks

Garment Features:

1. Crew sock
2. X-LOCK technology feature
3. Anatomical design
4. 1.25mm ultralight cushioning
5. Anti-abrasion seamless toe construction
6. Zoned mesh ventilation for increased breathability

Best For: Hot Weather

Colours: BLK/TTM, WHT/GRY

Size Range: S, M, L, XL

Fabric: 45% Olefin 43% Nylon 12% Lycra



UA5042e
Vectr Lightcushion No Show Sock

Garment Features:

1. No show sock
2. X-LOCK technology feature
3. Anatomical design
4. 2.5mm light cushioning
5. Anti-abrasion seamless toe construction
6. Zoned mesh ventilation for increased breathability

Best For: Mild Weather, Hot Weather

Colours: BLK/TTM, MAG/LGY, VBB/GRY, WHT/GRY

Size Range: S, M, L, XL

Fabric: 88% Nylon, 12% Lycra



UA5047e
Vectr Light Cush 1/4 Crew Sock

Garment Features:

1. 1/4 crew sock
2. X-LOCK technology feature
3. Anatomical design
4. 2.5mm light cushioning
5. Anti-abrasion seamless toe construction
6. Zoned mesh ventilation for increased breathability

Best For: Mild Weather, Hot Weather

Colours: BLK/TTM, WHT/GRY

Size Range: S, M, L, XL

Fabric: 88% Nylon, 12% Lycra



UA5052e
Vectr Light Cushion Crew Socks

Garment Features:

1. Crew sock
2. X-LOCK technology feature
3. Anatomical design
4. 2.5mm light cushioning
5. Anti-abrasion seamless toe construction
6. Zoned mesh ventilation for increased breathability

Recommended Activities: Mild Weather, Hot Weather
Colours: BLK/TTM, WHT/GRY, WHT/PCL, ALP/KWI, WHT/MDN, ECH/TRB
Size Range: S, M, L, XL
Fabric: 88% Nylon, 12% Lycra



UA5155e
Vectr Light Cushion Full Length Socks

Garment Features:

1. Full length sock
2. Graduated compression for improved circulation
3. X-LOCK technology feature
4. Anatomical design
5. 2.5mm light cushioning
6. Anti-abrasion seamless toe construction
7. Zoned mesh ventilation for increased breathability

Best For: Mild Weather
Colours: BLK/TTM, WHT/GRY, TTM/BLK, HPK/GRY
Size Range: S, M1, M2, L1, L2, XL
Fabric: 88% Nylon, 12% Lycra



UA6539e
Vectr Light Cushion Reflective Socks

Garment Features:

1. Full length sock
2. Graduated compression for improved circulation
3. X-LOCK technology feature
4. Anatomical design
5. 2.5mm light cushioning
6. Anti-abrasion seamless toe construction
7. Zoned mesh ventilation for increased breathability

Best For: Mild Weather
Colours: BLK/SRF
Size Range: S, M1, M2, L1, L2, XL
Fabric: 88% Nylon, 12% Lycra



UA5156e
Vectr Cushion Full Length Sock

Garment Features:

1. Full length sock
2. Graduated compression for improved circulation
3. X-LOCK technology feature
4. Anatomical design
5. 3.25mm cushioning
6. Anti-abrasion seamless toe construction
7. Zoned mesh ventilation for increased breathability

Best For: Cold Weather, Mild Weather
Colours: BLK/TTM, WHT/GRY
Size Range: S, M1, M2, L1, L2, XL
Fabric: 88% Nylon, 12% Lycra



UA5044e
Vectr Merino Light No Show Sock

Garment Features:

1. No show sock
2. X-LOCK technology feature
3. Anatomical design
4. 2.5mm light cushioning
5. Merino yarns for improved temperature regulation
6. Anti-abrasion seamless toe construction
7. Zoned mesh ventilation for increased breathability

Best For: Cold Weather, Mild Weather
Colours: BLK/TTM, GRY/GRY
Size Range: S, M, L, XL
Fabric: 21% Merino, 24% Acrylic, 44% Nylon, 11% Lycra



UA5049e
Vectr Merino Light Cushion 1/4 Crew Sock

Garment Features:

1. 1/4 crew sock
2. X-LOCK technology feature
3. Anatomical design
4. 2.5mm light cushioning
5. Merino yarns for improved temperature regulation
6. Anti-abrasion seamless toe construction
7. Zoned mesh ventilation for increased breathability

Best For: Cold Weather, Wet Weather
Colours: BLK/TTM, GRY/GRY
Size Range: S, M, L, XL
Fabric: 21% Merino, 24% Acrylic, 44% Nylon, 11% Lycra



UA5054e
Vectr Merino Light Cushion Crew Socks

Garment Features:

1. Crew sock
2. X-LOCK technology feature
3. Anatomical design
4. 2.5mm light cushioning
5. Merino yarns for improved temperature regulation
6. Anti-abrasion seamless toe construction
7. Zoned mesh ventilation for increased breathability

Best For: Cold Weather, Wet Weather
Colours: BLK/TTM, GRY/GRY
Size Range: S, M, L, XL
Fabric: 21% Merino, 24% Acrylic, 44% Nylon, 11% Lycra



UA5157e
Vectr Merino Light Cushion Full Length Sock

Garment Features:

1. Full length sock
2. Graduated compression for improved circulation
3. X-LOCK technology feature
4. Anatomical design
5. 2.5mm light cushioning
6. Merino yarns for improved temperature regulation
7. Anti-abrasion seamless toe construction
8. Zoned mesh ventilation for increased breathability

Best For: Cold Weather, Wet Weather
Colours: BLK/TTM, GRY/GRY
Size Range: S, M1, M2, L1, L2, XL
Fabric: 21% Merino, 24% Acrylic, 44% Nylon, 11% Lycra



UA5393e
Vectr Alpine Compression Socks

Garment Features:

1. Full length sock
2. Graduated compression for improved circulation
3. X-LOCK technology feature
4. Anatomical design
5. 2.5mm light cushioning
6. Merino yarns for improved temperature regulation
7. Lightly padded front shin section for protection under boots
8. Anti-abrasion seamless toe construction
9. Zoned mesh ventilation for increased breathability

Best For: Cold Weather, Wet Weather
Colours: BLK/TTM, TTM/MOS
Size Range: S, M1, M2, L1, L2, XL
Fabric: 21% Merino, 24% Acrylic, 44% Nylon, 11% Lycra



UA5043e

Vectr Cushion No Show Socks

Garment Features:

1. No show sock
2. X-LOCK technology feature
3. Anatomical design
4. 3.25mm cushioning
5. Anti-abrasion seamless toe construction
6. Zoned mesh ventilation for increased breathability

Best For: Cold Weather, Mild Weather
Colours: BLK/TTM, WHT/GRY, BSL/GRY, DYP/GRY
Size Range: S, M, L, XL
Fabric: 88% Nylon, 12% Lycra



UA5048e

Vectr Cushion 1/4 Crew Socks

Garment Features:

1. 1/4 crew sock
2. X-LOCK technology feature
3. Anatomical design
4. 3.25mm cushioning
5. Anti-abrasion seamless toe construction
6. Zoned mesh ventilation for increased breathability

Best For: Cold Weather, Mild Weather
Colours: BLK/TTM, WHT/GRY
Size Range: S, M, L, XL
Fabric: 88% Nylon, 12% Lycra



UA5053e

Vectr Cushion Crew Socks

Garment Features:

1. Crew sock
2. X-LOCK technology feature
3. Anatomical design
4. 3.25mm cushioning
5. Anti-abrasion seamless toe construction
6. Zoned mesh ventilation for increased breathability

Best For: Cold Weather, Mild Weather
Colours: BLK/TTM, WHT/GRY, BLK/WHT, WHT/BLK
Size Range: S, M, L, XL
Fabric: 88% Nylon, 12% Lycra



UA5690e
24/7 Compression Socks

Garment Features:

1. Full length sock
2. Light brushed cotton blend compression fabric
3. Graduated compression to promot increased blood flow and help prevent blood pooling
4. Padded zones on heels and balls of feet for maximum cushioning
5. Seamless linked toe cage for greater comfort
6. Vented toe panel for breathability

Recommended Activities Cold Weather, Mild Weather, Hot Weather
Colours: BLK/BLK
Size Range: XS, S, M, L, XL
Fabric: PWX 140D. 25% Nylon, 57% Cotton, 18% Elastane

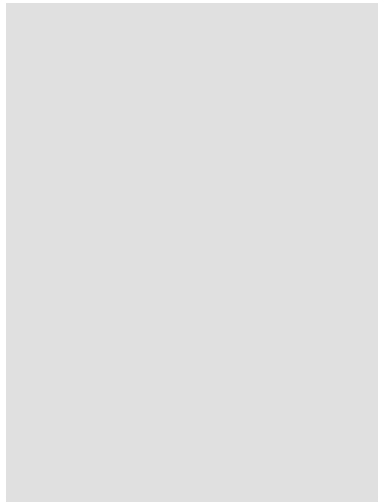

UQ6550e
Invisible Sock
3 Pack

Garment Features:

1. Invisible sock 3 pack
2. Quick-drying moisture wicking fabric
3. Heel, ball and toe cushioning
4. Air flow panelling
5. Seamless toe cage

Best For: Cold Weather, Mild Weather, Hot Weather
Colours: TRE/COL, WHT/BLK, BLK/WHT
Size Range: TBC
Fabric: Nylon/Polyester/Elastane

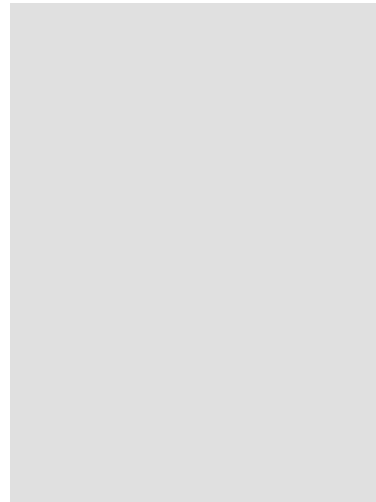

UQ6551e
3 Pack
Ankle Socks

Garment Features:

1. Ankle sock 3 pack
2. Quick-drying moisture wicking fabric
3. Heel, ball and toe cushioning
4. Air flow panelling
5. Seamless toe cage

Best For: Cold Weather, Mild Weather, Hot Weather
Colours: TRE/COL, WHT/BLK, BLK/WHT
Size Range: TBC
Fabric: Nylon/Polyester/Elastane



UA3513a
MCS Elite Comp
Arm Guards

Garment Features:

1. Compression arm guards (pair)
2. Quick-drying PWX highly powerful and flexible compression fabric
3. Forearm MCS for targeted reduction of muscle oscillation
4. Graduated fit promotes an efficient warm-up pre-exercise and faster recovery post-exercise
5. Signature X logo
6. Flatlock comfot seams to reduce chafe

Best For: Mild Weather, Hot Weather
Colours: BLK/GLD, BLK/NRO
Size Range: XXS, XS, S, M, L, XL, XXL
Fabric: PWX 70D. 72% Nylon, 28% Lycra



UA3196a
Compression
Arm Guard (Single)

Garment Features:

1. Single compression arm guard
2. Quick-drying PWX highly powerful, lightweight and flexible compression support to protect and stabilise the forearm, elbow and biceps and reduce muscle fatigue
3. Graduated fit promotes an efficient warm-up pre-exercise and faster recovery post-exercise
4. Signature X logo
5. Flatlock comfot seams to reduce chafe

Best For: Mild Weather, Hot Weather
Colours: BLK/SIL, WHT/SIL
Size Range: XXS, XS, S, M, L, XL, XXL
Fabric: PWX 70D. 72% Nylon, 28% Lycra



UA4009a
Flex Run Comp Arm Sleeves

Garment Features:

1. Compression seamless arm sleeves (pair)
2. Powerful and flexible knitted compression support to protect and stabilise the forearm, elbow and biceps and reduce muscle fatigue
3. Flexible, articulated elbow for greater freedom of movement
4. Graduated fit helps promote an efficient warm-up pre-exercise and faster recovery post-exercise
5. Signature X logo

Recommended Activities: Cold Weather

Colours: BLK/GRY, WHT/GRY
Size Range: XS, XS, S, M, L, XL, XXL
Fabric: 80% Nylon, 20% Lycra



UA3567a
Comp Flex Arm Sleeve (Single)

Garment Features:

1. Compression seamless arm sleeve (single)
2. Powerful and flexible knitted compression support to protect and stabilise the forearm, elbow and biceps and reduce muscle fatigue
3. Flexible, articulated elbow for greater freedom of movement
4. Graduated fit helps promote an efficient warm-up pre-exercise and faster recovery post-exercise
5. Signature X logo

Best For: Cold Weather

Colours: BLK/GRY, WHT/GRY
Size Range: XXS, XS, S, M, L, XL, XXL
Fabric: 80% Nylon, 20% Lycra



UA3064b
Elite Mcs Comp Calf Guards

Garment Features:

1. Compression calf guards (pair)
2. Quick-drying PWX highly powerful and flexible compression fabric
3. Calf MCS for targeted reduction of muscle oscillation
4. Graduated fit promotes an efficient warm-up pre-exercise and faster recovery post-exercise
5. Low profile design that can be worn on its own, with your favourite socks or even under your wetsuit for faster transition times in triathlon
6. Signature X logo
7. Flatlock comfort seams to reduce chafe

Best For: Mild Weather, Hot Weather

Colours: BLK/GLD, BLK/NRO
Size Range: XXS, XS, S, M, L, XL, XXL
Fabric: PWX 70D. 72% Nylon, 28% Lycra



UA1987b
Compression Calf Guards

Garment Features:

1. Compression calf guards (pair)
2. Quick-drying PWX highly powerful and flexible compression fabric
3. Graduated fit promotes an efficient warm-up pre-exercise and faster recovery post-exercise
4. Low profile design that can be worn on its own, with your favourite socks or even under your wetsuit for faster transition times in triathlon
5. Signature X logo
6. Flatlock comfort seams to reduce chafe

Best For: Warm Weather, Wet Weather

Colours: BLK/BLK, WHT/WHT, ALP/BLK, MDN/ECH
Size Range: XXS, XS, S, M, L, XL, XXL
Fabric: PWX 70D. 72% Nylon, 28% Lycra



UA5458b
X Compression Calf Sleeves

Garment Features:

1. 1ompression seamless calf sleeves (pair)
2. Powerful and flexible knitted compression support to protect and stabilise the lower leg to reduce muscle damage and shin splints
3. Graduated fit promotes an efficient warm-up pre-exercise and faster recovery post-exercise
4. Zoned ventilation for breathability
5. Seamless construction for greater comfort
6. Can be worn on its own or with your favourite socks

Best For: Cold Weather

Colours: BLK/BLK, TTM/BLK, WHT/WHT, VBB/GRY, MAG/LGY
Size Range: S, M, L, XL
Fabric: 80% Nylon, 20% Lycra



UQ6581f
**Multiply
Cap**

Garment Features:

1. 6-panel cap
2. Semi-curved brim
3. Stretch sweatband
4. Matte gunmetal signature X logo
5. Embroidered 2XU logo

Recommended Activities: Mild Weather, Hot Weather
Colours: BLK/SIL
Size Range: OSFA
Fabric: 65% Cotton 32% Nylon 3% Spandex

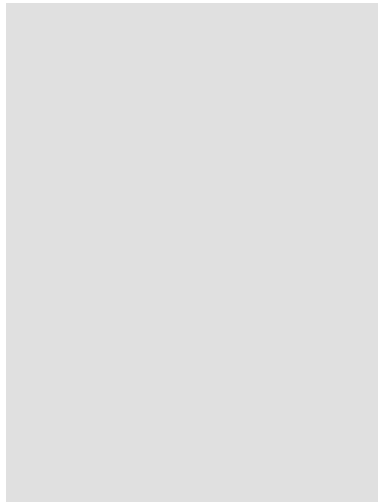

UQ6541f
**Packable Run
Cap**

Garment Features:

1. Lightweight 7-panel run cap
2. Semi-curved foldable binded brim
3. Moisture wicking sweatband
4. Reflective 2XU logo
5. Adjustable hook and loop closure
6. Reflective back strip with signature X logo

Recommended Activities: Mild Weather, Hot Weather
Colours: BLK/SRF
Size Range: OSFA
Fabric: 100% Polyester



UQ6542f
**Light Speed
Trucker**

Garment Features:

1. Lightweight run trucker
2. Soft EVA flat binded brim
3. Moisture wicking sweatband
4. Silicon logo patch on front panel
5. Open mesh ventilation
6. Adjustable tech buckle closure
7. Signature X logo tab on back

Recommended Activities: Mild Weather, Hot Weather
Colours: BLK/FLW
Size Range: OSFA
Fabric: 100% Polyester

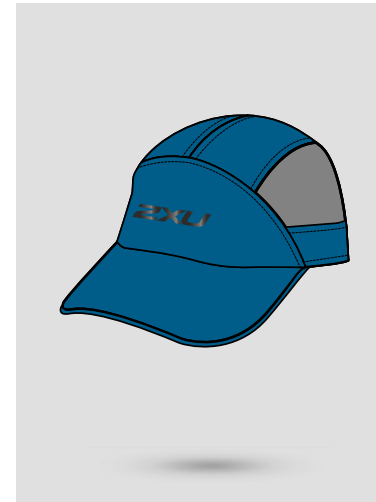

UQ6540f
**Light Speed
Cap**

Garment Features:

1. Lightweight 7-panel run cap
2. Semi-curved brim
3. Moisture wicking sweatband
4. Reflective 2XU logo on front panel
5. Laser cut perforation ventilation
6. Adjustable hook and loop closure
7. Reflective stripe on hook and loop closure
8. with signature X logo

Recommended Activities: Mild Weather, Hot Weather
Colours: CBY/BLK, CDB/MDN, AME/BLK, TRB/ECH
Size Range: OSFA
Fabric: 100% Polyester



UQ5685f
**Run
Cap**

Garment Features:

1. Lightweight 6-panel run cap
2. Semi-curved brim
3. Moisture wicking sweatband
4. 2XU logo on front panel and brim
5. Mesh ventilation panels
6. Adjustable hook and loop closure with silicon tab
7. 2XU logo on hook and loop closure

Recommended Activities: Mild Weather, Hot Weather
Colours: BLK/BLK, WHT/WHT, PCL/WHT, ALP/BLK, MDN/WHT, RUS/BLK
Size Range: OSFA
Fabric: 100% Nylon

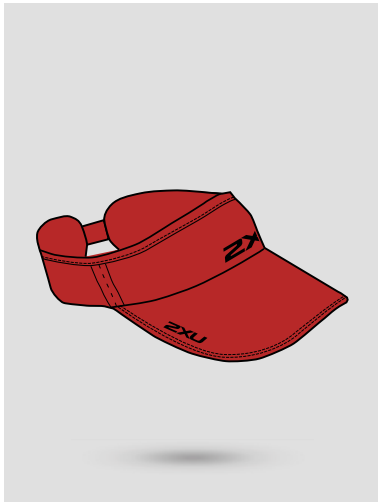

UQ5686f
Run
Visor

Garment Features:

1. Lightweight run visor
2. Semi-curved brim
3. Moisture wicking sweatband
4. 2XU logo on front panel and brim
5. Adjustable hook and loop closure with silicon tab
6. 2XU logo on hook and loop closure

Recommended Activities: Mild Weather, Hot Weather
Colours: BLK/BLK, WHT/WHT, PCL/WHT, ALP/BLK, MDN/WHT, RUS/BLK
Size Range: OSFA
Fabric: 100% Nylon



UQ6165f
Performance
Visor

Garment Features:

1. Lightweight run visor
2. Semi-curved brim
3. Moisture wicking forehead sweatband
4. 2XU logo on front panel and brim
5. Secure fit jaquard elastic headband with 2XU logo

Best For: Mild Weather, Hot Weather
Colours: BLK/BLK, WHT/WHT, PCL/WHT, ALP/BLK, MDN/WHT, RUS/BLK
Size Range: OSFA
Fabric: 100% Nylon



UQ3577f
Run
Beanie

Garment Features:

1. Skullcap beanie
2. Stretch brushed thermal fabric
3. Moisture-wicking technology
4. Reflective 2XU logo and trims

Best For: Cold Weather
Colours: BLK/BLK
Size Range: OSFA
Fabric: 88% Polyester 12% Spandex



UQ5352f
Thermal
Headband

Garment Features:

1. Thermal headband
2. Ceramic-infused X-HEAT fabric
3. Zero static cling and moisture-wicking
4. Naturally occurring antibacterial and anti-odour technology
5. Reflective 2XU logo

Best For: Cold Weather
Colours: BLK/BLK
Size Range: OSFA
Fabric: X-HEAT 58% Polyester 32% Viscose 10% Elastane



UQ6549f
Ignition
Headwear

Garment Features:

1. Headband
2. Recycled double-knit waffle construction
3. Moisture-wicking and quick-drying
4. Reflective 2XU logo

Best For: Cold Weather
Colours: TRB/BRF, GRM/SRF, ALP/KRF, PCL/WRF
Size Range: OSFA
Fabric: 94% Recycled Polyester 6% Spandex



UQ5692f
Skinny Headband
2 Pack

Garment Features:

1. 2 skinny headbands
2. Durable stretch elastic
3. Silicon strip for secure fit
4. 2XU logo

Best For: Hot Weather

Colours: BLK/WHT

Size Range: OSFA

Fabric: TBC



US1355f
Silicone Swim
Cap

Garment Features:

1. Silicone swim cap
2. Engineered from premium grade silicone for up-most strength and durability
3. Ergonomically designed for unparalleled comfort and security
4. Keeps head and hair dry
5. Ideal for latex intolerant athletes

Best For: Cold Weather, Wet Weather, Mild Weather, Hot Weather
BLK/BLK, SIL/SIL WHT/WHT

Colours: BLK/BLK, SIL/SIL WHT/WHT

Size Range: OSFA

Fabric: 100% Silicone



UQ4023k
Rival Goggle -
Mirror

Garment Features:

1. Mirrored swim goggle
2. Anatomical fit for comfort
3. Low profile design to reduce drag
4. Anti-fog lens coating for clear vision
5. Mirror lens for high glare conditions
6. Panoramic lenses for wider view
7. Durable adjustable strap for secure fit

Best For: Cold Weather, Wet Weather, Mild Weather, Hot Weather
SIL/BLK

Colours: SIL/BLK

Size Range: OSFA

Fabric: Lense: 100% Polycarbonate Plastic
Nose Bridge: 100% Nylon
Gasket: 100% Thermoplastic Rubber
Head Strap: 100% Silicone
Clip: 100% Polycarbonate Plastic



UQ3977k
Rival Goggle -
Smoke

Garment Features:

1. Smoke swim goggle
2. Anatomical fit for comfort
3. Low profile design to reduce drag
4. Anti-fog lens coating for clear vision
5. Smoked lenses for true depth perception in high glare conditions
6. Panoramic lenses for wider view
7. Durable adjustable strap for secure fit

Best For: Cold Weather, Wet Weather, Mild Weather, Hot Weather
BLK/CLR

Colours: BLK/CLR

Size Range: OSFA

Fabric: Lense: 100% Polycarbonate Plastic
Nose Bridge: 100% Nylon
Gasket: 100% Thermoplastic Rubber
Head Strap: 100% Silicone
Clip: 100% Polycarbonate Plastic



UQ3976k
Rival Goggle -
Clear

Garment Features:

1. Clear swim goggle
2. Anatomical fit for comfort
3. Low profile design to reduce drag
4. Anti-fog lens coating for clear vision
5. Clear lenses let in maximum amount of light in low-light conditions
6. Panoramic lenses for wider view
7. Durable adjustable strap for secure fit

Best For: Cold Weather, Wet Weather, Mild Weather, Hot Weather
CLR/BLU

Colours: CLR/BLU

Size Range: OSFA

Fabric: Lense: 100% Polycarbonate Plastic
Nose Bridge: 100% Nylon
Gasket: 100% Thermoplastic Rubber
Head Strap: 100% Silicone
Clip: 100% Polycarbonate Plastic



UQ3805g
Transition
Bag

Garment Features:

1. Triathlon backpack
2. Ultra-durable shell
3. Padded shoulder straps
4. Contoured back panel
5. Hip belt and chest strap
6. Helmet stow
7. Side water bottle holders
8. Waterproof pouch
9. Multiple zipped organiser pockets
10. Reflective logo and trims
11. 35L capacity

Recommended Activities: Cold Weather, Wet Weather, Mild Weather, Hot Weather
Colours: BLK/BLK
Size Range: OSFA
Fabric: Outer: 100% Nylon
 Lining: 100% Polyester



UQ3803g
Distance
Backpack

Garment Features:

1. Everyday backpack
2. Ultra-durable shell
3. Padded shoulder straps
4. Contoured back panel
5. Hip belt and chest strap
6. Secure laptop compartment
7. Side water bottle holders
8. Multiple zipped organiser pockets
9. Reflective logo and trims
10. 22L capacity

Best For: Cold Weather, Wet Weather, Mild Weather, Hot Weather
Colours: BLK/BLK
Size Range: OSFA
Fabric: Outer: 100% Nylon
 Lining: 100% Polyester



UQ3804g
Gym
Bag

Garment Features:

1. Gym duffel bag
2. Ultra-durable shell
3. Removable adjustable shoulder strap with padded cover
4. Base protection studs
5. Multiple zipped organiser pockets
6. Side water bottle holder
7. Inner shoe compartment
8. 30L capacity

Best For: Cold Weather, Wet Weather, Mild Weather, Hot Weather
Colours: BLK/BLK
Size Range: OSFA
Fabric: Outer: 100% Nylon
 Lining: 100% Polyester



UQ5462g
Run
Arm Band

Garment Features:

1. Mobile phone arm band
2. Snap seal closure
3. Showerproof
4. Fits up to iPhone 6+ or Samsung Note 7
5. Reflective 2XU logo for low-light visibility
6. Comfortable stretch fabric with hook and loop fastening

Best For: Cold Weather, Wet Weather, Mild Weather, Hot Weather
Colours: BLK/BLK
Size Range: OSFA
Fabric: Polyester Silicone



UQ5340h
Run
Glove

Garment Features:

1. Skullcap beanie
2. Stretch brushed thermal fabric
3. Touch screen compatible finger tips
4. Moisture-wicking and quick-drying
5. Reflective 2XU logo
6. Button snap to keep them together

Best For: Cold Weather
Colours: BLK/SIL
Size Range: S - L
Fabric: 88% Polyester 12% Spandex



UQ5360g
Run
Belt

Garment Features:

1. Run belt
2. Adjustable elastic clip belt for comfort
3. Sits flat against body to eliminate flapping
4. Zip pocket for secure storage of phone or keys
5. Reflective 2XU logo for low-light visibility

Best For: Cold Weather, Wet Weather, Mild Weather, Hot Weather
Colours: BLK/BLK
Size Range: OSFA
Fabric: 87% Polyester 13% Spandex



UQ3800g
Nutrition Race
Belt

Garment Features:

1. Triathlon race belt
2. Safe and secure design - clear display of race details
3. Low profile for a comfortable feel against the hips
4. Fully adjustable
5. Quick-release toggle

Best For: Mild Weather, Hot Weather
Colours: BLK/BLK
Size Range: OSFA
Fabric: 85% Polyester 15% Elastane



UQ3799g
Timing Chip
Strap

Garment Features:

1. Ankle timing strap
2. Nylon and neoprene construction
3. Adjustable hook and loop strap for secure fit
4. Comfortable design with low chafing

Best For: Mild Weather, Hot Weather
Colours: BLK/BLK
Size Range: OSFA
Fabric: 100% Nylon

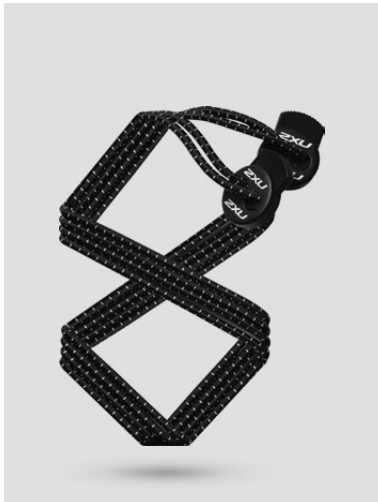

UA1855g
Performance
Locked Laces

Garment Features:

1. Race tested, lightweight, secure and reliable
2. Ergonomic 'quick release/retain' lace locks for the fastest transitions
3. Includes laces
4. Suitable for all footwear
5. Lightweight and low profile

Recommended Activities: Cold Weather, Wet Weather, Mild Weather, Hot Weather
Colours: BLK/BLK, WHT/WHT
Size Range: OSFA
Fabric: 30% Polyester 70% Spandex



UQ4812g
220z
Waterbottle

Garment Features:

1. 22oz waterbottle
2. BPA-free to ensure no bad taste
3. Soft poppet with wide channel for increased water flow
4. Engineered leak-proof lid
5. Screw top lid is easy to open

Best For: Cold Weather, Wet Weather, Mild Weather, Hot Weather
Colours: BLK/BLK, CLR/BLX
Size Range: OSFA
Fabric: 100% Polyethylene



UQ4813g
260z
Waterbottle

Garment Features:

1. 26oz waterbottle
2. BPA-free to ensure no bad taste
3. Soft poppet with wide channel for increased water flow
4. Engineered leak-proof lid
5. Screw top lid is easy to open

Best For: Cold Weather, Wet Weather, Mild Weather, Hot Weather
Colours: BLK/BLK, CLR/BLX
Size Range: OSFA
Fabric: 100% Polyethylene

SIZE GUIDE



QUAD SLEEVES

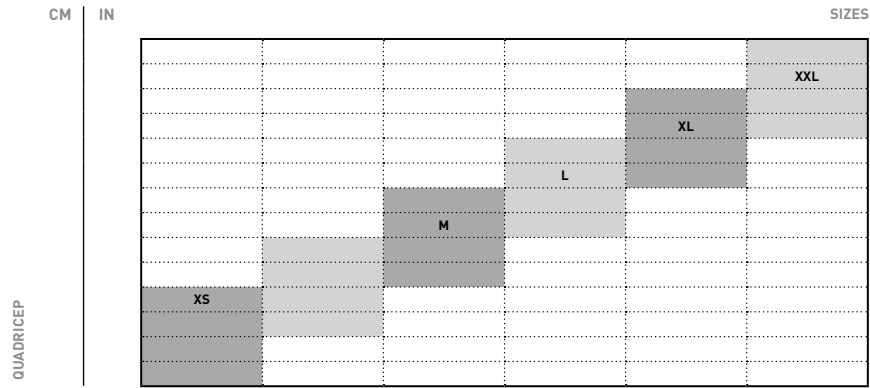

LEG SLEEVES

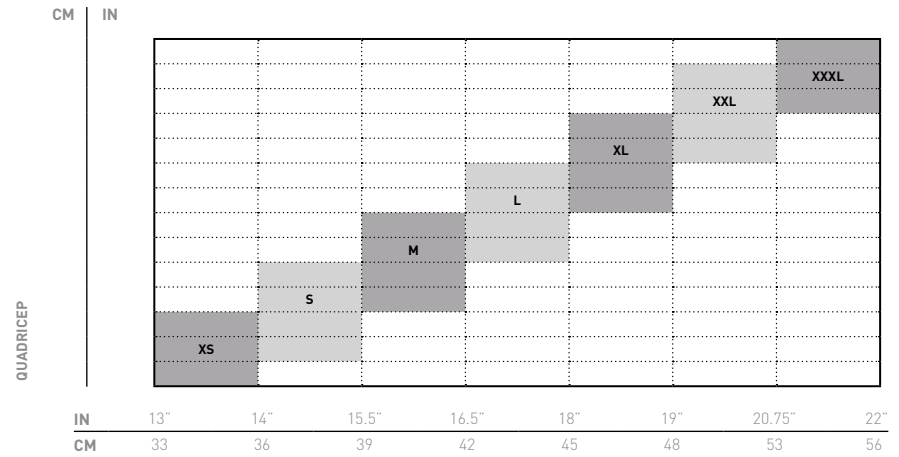

ARM GUARD / SLEEVES

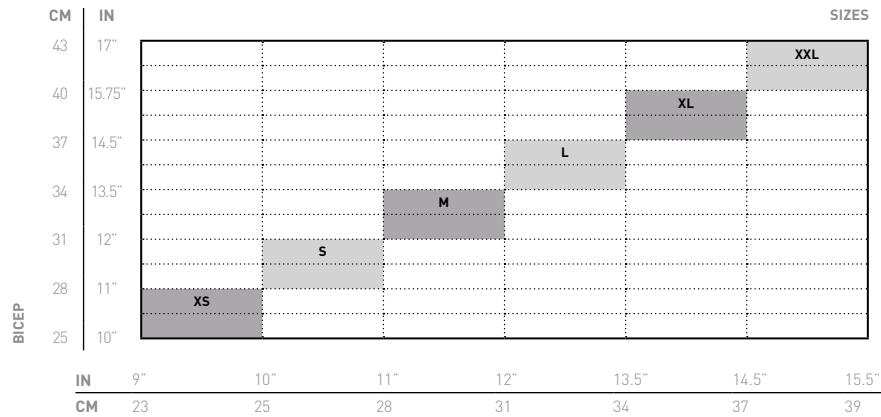

CALF GUARD / SLEEVES

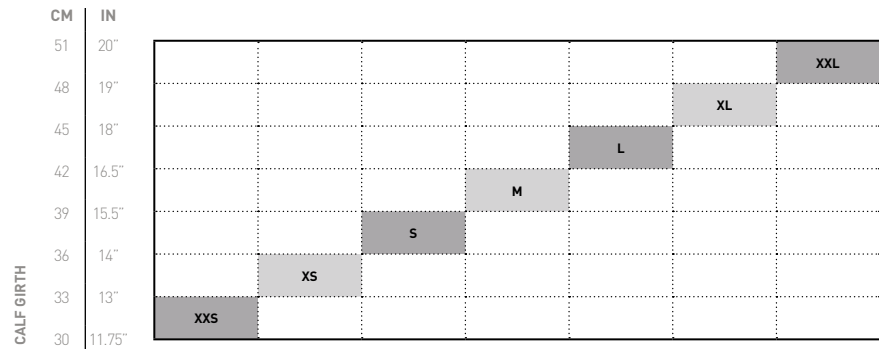

*Double extra large only available for calf guards

QUAD SLEEVES

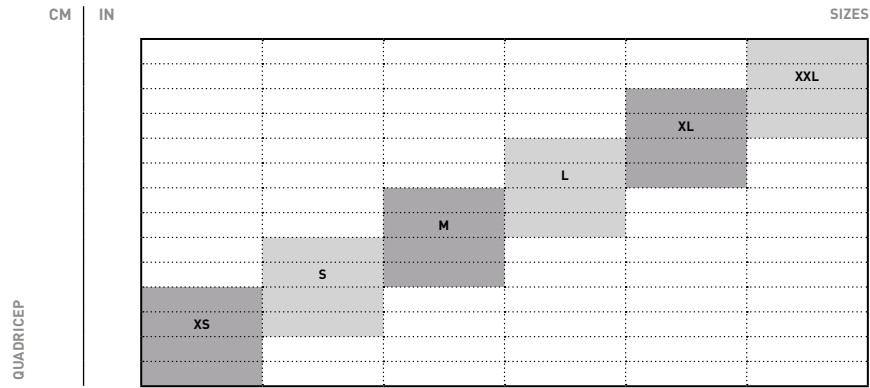

LEG SLEEVES

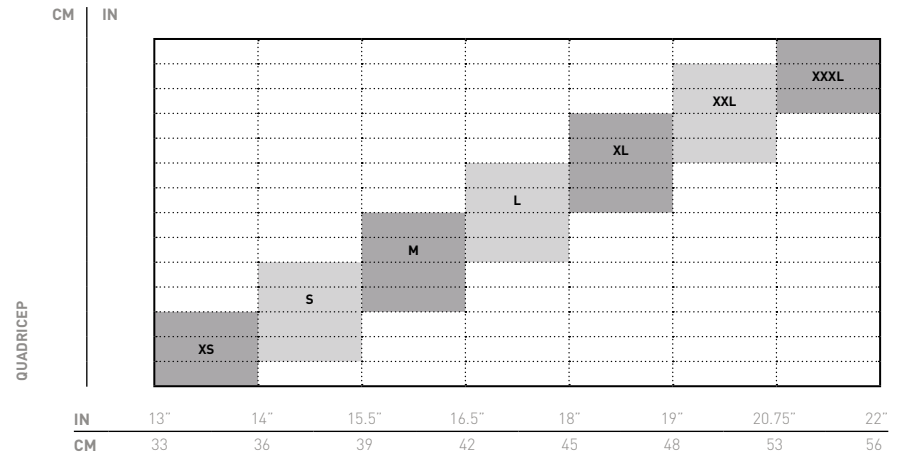

ARM GUARD / SLEEVES

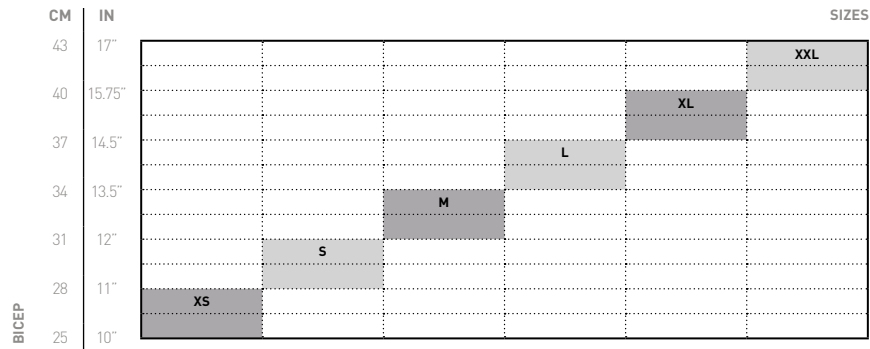

CALF GUARD / SLEEVES

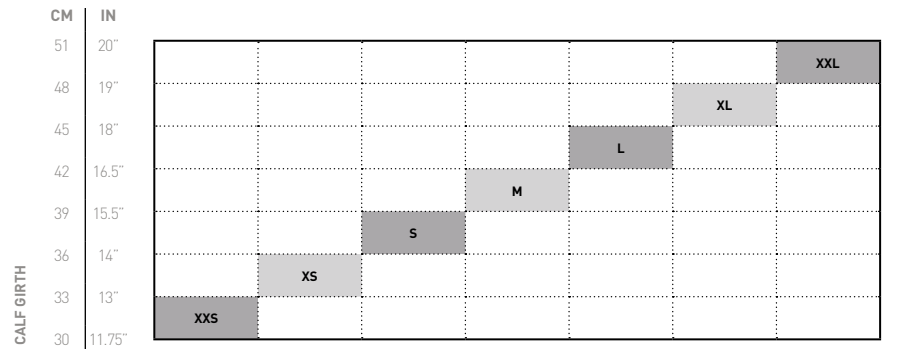

VECTR SOCKS - LOWER LENGTH

	SMALL	MEDIUM	LARGE	X-LARGE
EU	35 – 37.5	38 – 41.5	42 – 46	46.5 – 48.5
US-M	3.5 – 5.5	6 – 8	9 – 12	12.5 – 14
US-W	5 – 7	7.5 – 9.5	10 – 13	14 – 15.5

VECTR SOCKS - FULL LENGTH

SHOE SIZE		SMALL	MEDIUM-1	MEDIUM-2	LARGE-1	LARGE-2	X-LARGE
	EU		35 – 37.5	38 – 41.5	38 – 41.5	42 – 46	42 – 46
US-M		3.5 – 5.5	6 – 8	6 – 8	9 – 12	9 – 12	12.5 – 14
US-W		5 – 7	7.5 – 9.5	7.5 – 9.5	10 – 13	10 – 13	14 – 15.5
CALF SIZE	CM	30 – 37	32 – 37	38 – 43	36 – 40	41 – 46	43 – 50
	INCH	11.75 – 14.5	12.5 – 14.5	15 – 17	14 – 15.75	16 – 18	17 – 19.75

GLOSSARY

105D Power Mesh PWX Compression

The latest 105D Power Mesh PWX Compression technology offers incredible stabilisation for greater power output and reduced muscle movement to minimise fatigue. Powerful mesh construction delivers increased ventilation to keep the body cool, as well as aerodynamic, dimpled air flow technology for enhanced speed and moisture management.

39 Cell Neoprene

The most buoyant neoprene available, with a thickness ranging from 1mm to 5mm (5mm is the maximum permitted).

45 Cell Neoprene

Flexible material with a 1mm thickness, applied mainly to sleeves for ultimate flexibility, comfort and freedom of movement.

X-Lite

Super lightweight 96gsm fabric for a near-weightless performance. This lightweight fabric offers superior breathability and cooling for maximum performance gains. With a revolutionary knit structure this fabric offers unrivaled moisture management. Hyper Stretch Double-Sided Nylon For durability and flexibility.

Interlock Compression

Engineered with 40+40D nylon and latest elastomeric fibres, this 2XU fabric delivers strength, power, flexibility and durability with superior hand feel. Interlock is body sculpting and super flexible, with impressive muscle support and definition.

LD Chamois

Quick-drying long course triathlon chamois fused onto a high-density, hydrophobic foam base to manage moisture and deliver the comfort required to go the distance. Offers ample support for the bike while remaining discreet on the run.

Muscle Containment Stamping (MCS)

A revolutionary fabric support system traced over key muscle, tendon and fascia groups with targeted compression technology to wrap precise areas to further reduce muscle oscillation and damage. The advanced engineering provides greater compression power without excessive bulk.

Pro LD Chamois

Italian designed and made, this multi-layered chamois is exclusive to 2XU. Includes 80-density low-water absorption foam for added support in the aero position, and soft edging for less bulk on the run. Extremely comfortable and low profile, while still providing the cushioning required for long distance racing.

PWX Compression

2XU's proprietary PWX compression fabric has been developed for sport using medical technology. Developed at the yarn level, a compression fabric that is highly powerful but also lightweight and flexible. This is an oxymoron that no other brand has achieved. 2XU's proprietary knit fabrication uses highly durable high filament nylon yarns and the most powerful and long lasting elastane yarns to ensure our compression fabric retains consistent power, shape and comfort with repeat usage.

PWX 70D

Our most flexible and breathable compression fabric. Light yet offering powerful compression and multidirectional stretch. Combining nylon and Invista Lycra yarns for greater durability. Moisture wicking, antibacterial and UPF 50+ sun protection.

PWX 105D

Powerful yet still light, this fabric is engineered for sports. Offering powerful compression and multi-directional stretch. Combining nylon and Invista Lycra yarns for greater durability. Moisture wicking, antibacterial and UPF 50+ sun protection.

PWX 105D+

This latest PWX fabric offers powerful compression in a mid weight for greater coverage. Multidirectional stretch for consistent power. Combining nylon and INVISTA Lycra yarns for greater durability. Moisture wicking, antibacterial and UPF 50+ sun protection.

Sensor Mesh X

Utilising high filament Nylon Lycra® blend, this durable water repellent fabric offers optimal air flow and moisture management.

SBR Power

Built from 70D elastane, SBR POWER offers unmatched power, durability and strength. Featuring high-denier Nylon yarn for impressive support and moisture management, plus mid-level gauge for muscle stabilisation.

SBR Skin

Powerful 70D elastane delivers muscle support and enhanced performance. Excellent stretch and recovery memory allows the garment to move with the body from start to finish.

SBR Vent

This Italian fabric delivers extreme cooling properties and exceptional aerodynamics. Low-denier construction, 3D mesh structure and cross-section yarns ensure this fabric keeps your body cool, dry and comfortable.

Speedline Chamois

Quick drying and low profile, this chamois is designed for moisture management and support in the saddle, while remaining incredibly lightweight and discreet on the run.

Swiss Vent

Industry-leading fabric engineered by the world's premier Swiss fabric mill. High-ventilation matrix knit, Coldblack heatblocking technology, X-Cross polyester yarns and fine denier properties combine to create the world's leading heat beating triathlon fabric. Tested and proven by the world's best. Vapor Featuring micro-filament polyester yarn with hydrophobic properties, this fabric offers supreme comfort and drape. A lower denier (finer) yarn on the outside wicks moisture from the higher denier (thicker) yarn on the inside to keep the wearer comfortable and dry. Zero cling to the body.

Yamamoto Limestone Neoprene

The world's most flexible swim neoprene, manufactured in Japan from ecological limestone rather than oil-based materials. A patented closed-cell neoprene rubber with an expansion ratio seven times greater than conventional wetsuit materials, delivering enhanced comfort and an unprecedented range of movement.

Yamamoto SCS Coated Neoprene

Unique patented material that features a specifically processed coating applied over a patented closed-cell neoprene rubber. This coating results in a micellar surface that repels water when in contact with air and exhibits hydrophilic properties when under water, ensuring ultra-low resistance in competitive conditions for enhanced comfort and reduced water resistance, with complete freedom of movement. Features an expansion ratio seven times greater than conventional wetsuit materials for easy wear in all conditions.



2XU

SEASONAL
LOOKBOOK

H2 2020

2XU

HUMAN PERFORMANCE. MULTIPLIED.



THE COMPLETE ATHLETE CYCLE

There are no shortcuts to improving performance and the most effective thing you can do to maximise your performance occurs well before you step foot onto the field, court, track, stage or pool.

By looking at the complete athlete cycle, 2XU delivers product that performs across all facets of the process, leading to greater performance, no matter our finish line.

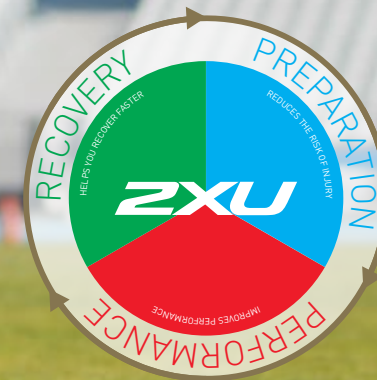

THE WORLD'S BEST. TESTED. PROVEN. FACT.

2XU is the global leader in converting scientific, evidence-based research into the world's best performance-enhancing compression garments.

We have scientifically engineered the **LIGHTEST, MOST POWERFUL** and **MOST FLEXIBLE** compression fabric in the world, which retains its strength and integrity well beyond our competitors. Our garments are independently tested at every stage of development to give athletes the ultimate edge in training, performance and recovery. But don't take our word for it - more than a decade of research by the world's leading independent research institutes shows the true biomechanical and physiological benefits of 2XU compression.

#1 POWER BALANCE & RESIDUAL STRETCH

WEFT & WARP STRETCH (%)

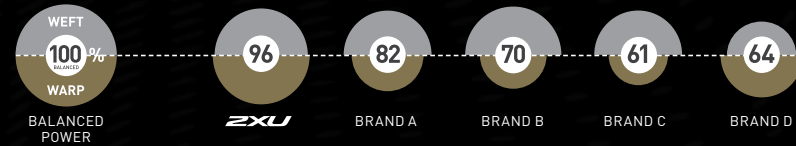

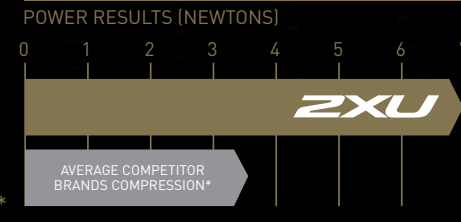

MORE THAN TWICE THE COMPRESSION POWER OF OTHER BRANDS*





*BASED ON AVERAGE NEWTONS MEASURED FOR 8 COMPETITOR COMPRESSION BRANDS

PERFORMANCE

GAINS OF UP TO **10.6**⁽³⁾ 
SECONDS
 OVER A 5KM RUN

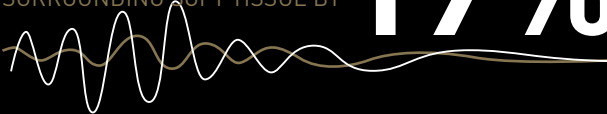
5%⁽⁶⁾ 
 PEAK POWER GAINS
18%⁽⁷⁾ 
 BLOOD FLOW INCREASE TO THE QUADS

REDUCES OSCILLATORY PROPERTIES⁽⁴⁾
 OF QUADRICEPS, CALVES AND SURROUNDING SOFT TISSUE BY **19%**

REDUCES HEART RATE ⁽⁵⁾
 BY UP TO 2.5% FOR EXERCISE BOUTS LASTING UP TO 15mins

LOWERS MARKERS ⁽⁸⁾
 UP TO **18%**
 OF BLOOD CLOTTING IN A MARATHON

POWER IMPROVEMENT⁽⁹⁾ OF UP TO 1.4% FOR EXERCISE BOUTS UP TO 30 MINUTES
 EVEN IMPROVEMENT OF THIS MAGNITUDE MAY INFLUENCE COMPETITION SUCCESS 

REDUCES LEG SORENESS BY 47% 
 WHEN WORN BETWEEN REPEATED MAXIMAL RUNNING BOUTS ⁽¹⁰⁾

LOWERS HEART RATE 
 WHEN WORN DURING ⁽¹¹⁾ REPEATED-SPRINT EXERCISE

INCREASES CALF MUSCLE OXYGENATION ⁽¹²⁾
BY 6.9%

RECOVERY

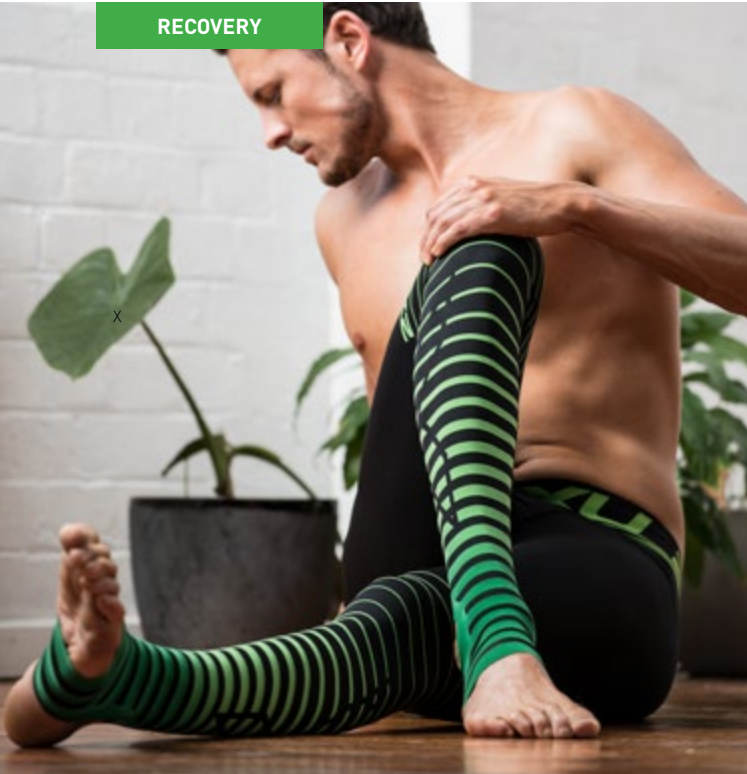

REDUCES MUSCLE SORENESS

2.5 TIMES IN THE 24 HOURS AFTER DAMAGING EXERCISE AND 3.8 TIMES AFTER 48 HOURS

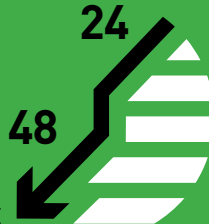

[16]

4.8% INCREASE IN BLOOD LACTATE REMOVAL

IN A 60 MINUTE RECOVERY PERIOD



[13]

REDUCES MUSCLE SORENESS

FROM POST-MARATHON TO 24 HOURS POST-MARATHON



BY 91%

[15]

REDUCES SWELLING



TO THE THIGH BY 1.1cm TO THE CALF BY 0.6cm BASED ON GIRTH MEASUREMENT WHEN WORN IN A 60 MINUTE RECOVERY PERIOD

X

[14]



POWER IMPROVEMENTS OF UP TO 2%

WHEN WORN FOR RECOVERY BETWEEN REPEAT BOUTS OF EXERCISE

[17]

FIELDS OF PLAY

To drive increased consumer appeal within our 'Fields of Play' strategy, we aim to use our Elite, Perform & Active segmentation to create product that caters to athletes of all levels, while also taking into account the complete athlete cycle of Preparation, Performance & Recovery.

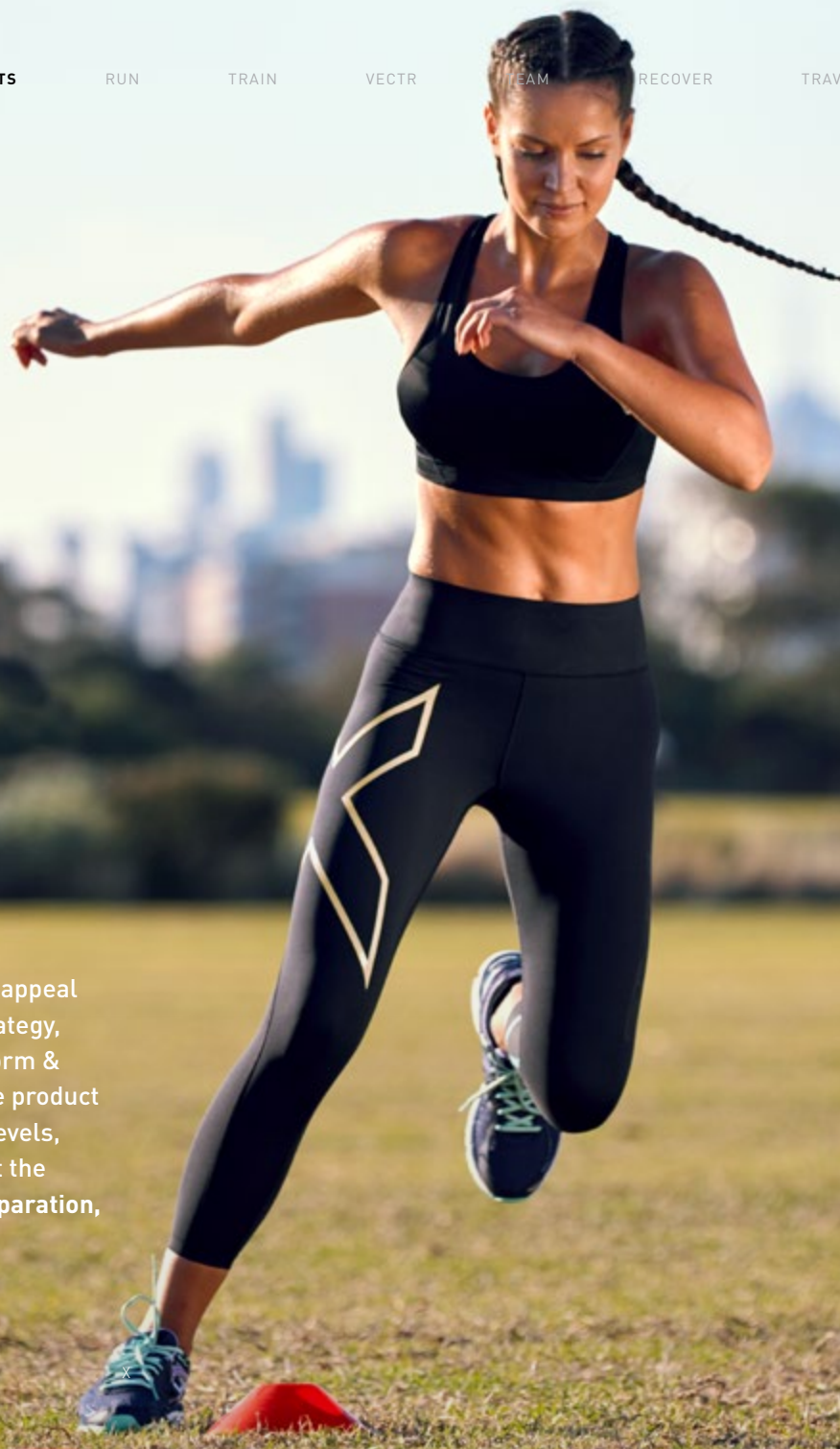

RUN-
NING / TECHNICAL
PERFORMANCE
COMFORT

MEN'S
TRAIN-
ING / COMFORT
PERFORMANCE
VERSATILITY

WOMEN'S
TRAIN-
ING / COMFORT
PERFORMANCE
VERSATILITY

MULTI-
SPORT / HERITAGE
& ENDURANCE PERFORMANCE
INNOVATION

CONSUMER NEEDS

RUNNING

MEN'S TRAINING

WOMEN'S TRAINING

MULTI-SPORT / ENDURANCE

TWO TIMES YOU

ELITE

Highly committed and competitive runners focused on winning or beating their personal best. They are most often part of a run club and are training towards key events from 10K, Half Marathon and Marathon+ distance.

With multiple training sessions each week, they are looking for the performance and recovery benefits that 2XU provides.

ELITE

They are serious about their training, attending sessions 5+ times per week. Most likely they are attending high intensity or functional training sessions where the focus is on developing strength and improving aerobic capacity.

They are seeking products that provide support to push their limits in these sessions.

ELITE

They are serious about their training, attending sessions 5+ times per week. Most likely they are attending high intensity or functional training sessions where the focus is on developing strength and improving aerobic capacity.

They are seeking products that help them perform at their peak and back it all up again for the next session.

ELITE

Highly committed and competitive athletes focused on winning or beating their personal best. They are most often part of a Triathlon club and are training towards key events (Olympic distance – Ironman).

With multiple training sessions each week, they are looking for the performance and recovery benefits that 2XU provides to keep them performing at their peak.

PERFORM

A regular runner, running multiple times per week they are focused on achievement be that a new distance, faster time or the completion of a mass participation event.

They are looking for products that help them achieve their best and eliminate soreness or injury post-run.

PERFORM

Committed to improving their health and physical appearance, they are part of a gym or studio that they attend 2-3 times per week. Functional training will be a staple as will be some low impact studio sessions.

They choose products that make them feel good when working out, through providing coverage and support as well as looking their best.

PERFORM

Focused on improving their physical performance, they regularly 'hit the gym' or attend functional classes aiming to increase muscle and reduce excess weight.

They look for products that help them work out free from distractions whilst looking good.

PERFORM

Whilst not necessarily describing themselves as a Triathlete, they are incredibly fit and take part in a number of triathlon events each season as a means of staying fit and achieving physical goals.

They want to look the part and have products that help them train and race to their full potential.

ACTIVE

They don't consider themselves a 'runner' but are committed to getting out and going for a run or jog. More often than not these are people looking to improve their health and physical fitness with running being the easiest way to get moving.

They are looking for products that help them run easier and eliminate the pain they feel post-run.

ACTIVE

With a primary focus on staying 'fit', these women see training as a means to an end - both from a physical and well-being point of view. They may be a member of a gym or studio, have a PT, and workout 1-2 times per week.

They are seeking products that provide comfort and support in the areas they need it.

ACTIVE

These guys are working out to get themselves back in shape and stay on top of their current weight. It is most likely that their training is a mixture of weights and cardio activity designed to improve their physical appearance.

ACTIVE

New to the sport of triathlon, they have completed one or more 'enticer' triathlons and have now committed to competing more frequently.

They are looking for products that help them perform and enjoy the experience.

X

X

PRODUCT SOLUTIONS

TWO TIMES YOU

x

RUN

TRAINING

TEAM SPORTS

RECOVERY

MATERNITY

ELITE	GHST	MCS RUN WIND DEFENCE	MCS X-TRAINING			POWER RECOVERY	
PERFORM	XVENT	CORE/TEAM RUN DASH THERMAL PWX	XCTRL	CORE/TEAM ACCELERATE	CORE/TEAM CUSTOM COMPRESSION AND APPAREL	REFRESH RECOVERY	PRENATAL POSTNATAL
ACTIVE	ACCESSORIES	ASPIRE	ACCESSORIES	ASPIRE	ASPIRE		

x

x

CONSUMER GROWTH TRENDS

TWO TIMES YOU

PERFORMANCE MATTERS

INSIGHTS: Continued growth in mass participation events across Running and Triathlon with participants looking to push their performance and achieve a new personal best.

The mass take up of wearable technology and performance tracking apps such as Strava highlight the desire to track, share and improve personal performance

IMPLICATIONS: 2XU performance positioning enables consumers to prepare, perform and recover like never before and achieve their personal best.

THE GREAT OUTDOORS

INSIGHTS: Recreational and competitive running continues to grow on the back of increased number of organised outdoor running events such as Park Run.

Training is also moving outdoor to complement traditional gym workouts.

IMPLICATIONS: 2XU performance fabrics with proven breathability, cooling and moisture management technology assists training and competing in a broad range of outdoor environment

TRAINING TO TRAIN

INSIGHTS: Rapid global growth in functional training across all consumer groups shows no signs of slowing.

Training also underpins majority of other activities (team sports, running and triathlon) to build strength and functional fitness

IMPLICATIONS: 2XU Compression enables consumers to increase their power for their best workout and aid their recovery so they can back it up again the next day.

ACTIVE RECOVERY

INSIGHTS: Broad understanding for the role that recovery plays for athletes of all levels to not only prevent injury but aid performance.

IMPLICATIONS: 2XU Recovery range is proven to aid recovery to keep consumers performing day in, day out.

x

x

x

MAJOR EVENTS DRIVING CONSUMER DEMAND

TWO TIMES YOU

x

2020	JUL	AUG	SEP	OCT	NOV	DEC
MAJOR EVENTS	TOKYO OLYMPICS	TOKYO PARALYMPICS				
RUNNING	RUN MELBOURNE		BERLIN MARATHON MOSCOW MARATHON	MELBOURNE MARATHON AMSTERDAM MARATHON	NEW YORK MARATHON	SINGAPORE MARATHON
TRIATHLON	CHALLENGE ROTH	ITU WORLD CHAMPIONSHIP EDMONTON		TRIATHLON WORLD CHAMPIONSHIP KONA	TRIATHLON 70.3 WORLD CHAMPIONSHIP TAUPO	

x

x

INSIGHTS / 10

CORE & SEASONAL COLOURS

MEN

CORE COLOURS



SEASONAL COLOURS



REFLECTIVE COLOURS



MARLE/HEATHER COLOURS

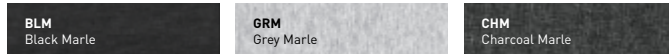

PATTERN COLOURS



WOMEN

CORE COLOURS



SEASONAL COLOURS

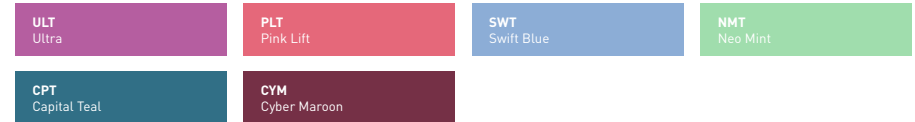

REFLECTIVE COLOURS



MARLE/HEATHER COLOURS

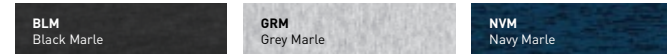

PATTERN COLOURS

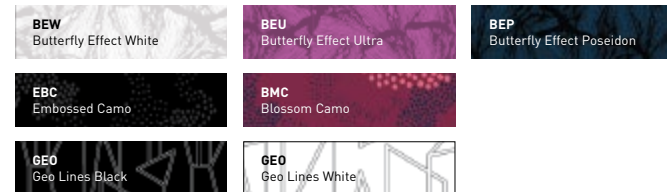

PATTERN COLOURS



X

X

X



2XU

INSIGHTS

RUN

TRAIN

VECTP

TEAM

RECOVER

TRAI

MATERN

ACCESSORIES

PRODUCT INFO

TWO TIMES YOU

X

X

TWENTY / 2

X

COLOUR STORIES: CHERRY BLOSSOM CAMO

INSIGHTS / 12

2XU

INSIGHTS

RUN

TRAIN

VECTR

TEAM

RECOVER

TRAVEL

MATERNITY

ACCESSORIES

PRODUCT INFO

TWO TIMES YOU

COLOUR STORIES:
BUTTERFLY
EFFECT



X

X



NEW SEASON LOOKS



1. MR6275a XCTRL Short Sleeve Tee SLE/BLK, MA6386b Accelerate Compression Shorts BLK/NRO, MR6279b XCTRL 5" Shorts BLK/BLK.

2. MR6210a GHST 55 Tee MXX/SRF, GHST 3" Shorts BLK/BRF, U05693F Vented Run Cap MXX/BRF, UA9092e Vectr Light Cushion Crew Socks UAQ/TRB.

3. WR6283a Utility Insulation Jacket WHT/BLK, WR6297a Contender Singlet BLK/BLK, WA6110b Fitness New Heights Compression Tights EBC/BOL.

x

RUN COMPRESSION & APPAREL

As one of the world's largest participation sports, running encompasses athletes of all abilities.

From the highly committed, to the everyday active, the runner's body remembers how difficult it is to start, but their mind loves the challenge of beating yesterday's best.

Designed to beat the elements, the 2XU RUN collection helps you focus on your finish line, whatever it may be.

x



PURSUIT INSULATION JACKET

Built with a water-resistant shell and lightweight down insulation, the Pursuit Insulation Jacket allows you to attack your run, regardless of the weather.

1/ STAY WARM

Lightweight and compressible 600 fill-power down insulation provides a cocoon of warmth.

3/ ESSENTIAL STORAGE

Chest and front zipped pockets provide adequate safe storage for your phone, cards or keys during any physical activity.

4/ NO SMELL

Antibacterial and anti-odour technology on lining keeps you fresher for longer between washes, reducing your environmental footprint.

Product Code MR6223a / WR6225a

Recommended Activities
Cold & Wet Weather Running.

Colours Available

Men: BLK/UAQ, Women: BLK/PLT.

2/ STAY DRY

Stretch knit, downproof shell with environmentally responsible C6 DWR treatment to withstand rain and showers.

4/ BE SEEN

Reflective logos and colour panel on chest for greater visibility in low-light conditions.

Size Range

Men: XS, S, M, L, XL, XXL. Women: XXS, XS, S, M, L, XL

Fabric Main Double Weave: 100% POLYESTER,
Main Single Weave: 100% Polyester,
Fill: 90% Down, 10% Feather



TWO TIMES YOU



FOUR / 16



MR6231a / WR6233a

PURSUIT THERMAL
1/4 ZIP
LONG SLEEVE TOP



1/ STAY WARM

Recycled Polyester double-knit waffle construction traps body heat in, while cuffs flip over to become mittens, keeping you warmer.

2/ BE SEEN

Reflective logos for greater visibility in low-light conditions.

3/ ESSENTIAL STORAGE

A zip pocket on the arm offers a bounce-free solution for securing cards or keys while you run.

4/ NO SMELL

Antibacterial and anti-odour technology keeps you fresher for longer between washes, reducing your environmental footprint.

Recommended Activities Cold Weather Running.

Colours Available Men: GRM/SRF, POS/SRF. Women: GRM/SRF, PLT/SRF.

Size Range Men: XS, S, M, L, XL, XXL. Women: XXS, XS, S, M, L, XL, XL.

Fabric 94% Recycled Polyester, 6% Spandex.

GARMENT FEATURES

- 1/4 zip long sleeve
- Stand collar
- Recycled double-knit waffle construction
- Arm zip pocket
- Cuffs with thumb-holes and flip over mittens
- Reflective logos and trims
- Antibacterial and anti-odour technology



MR6340a / WR6342a

HEAT
BASE LAYER
LONG SLEEVE TOP



1/ STAY WARM

Revolutionary ceramic-infused BIO-HEAT X fabric warms up with you to combat the cold.

2/ STAY DRY

BIO-HEAT X fabric wicks sweat from the skin's surface to keep you dry, with zero static cling.

3/ NO SMELL

Antibacterial and anti-odour technology keeps you fresher for longer between washes, reducing your environmental footprint.

Recommended Activities Cold Weather Running.

Colours Available BLM/SRF.

Size Range Men: XS, S, M, L, XL, XXL. Women: XXS, XS, S, M, L, XL, XL.

Fabric 62% Polyester, 33% Rayon, 5% Elastane.

GARMENT FEATURES

- Long sleeve base layer
- Ceramic-infused Bio-Heat X fabric
- Antibacterial and anti-odour technology



MA5394b

THERMAL
ACCELERATE
COMPRESSION
TIGHTS



1/ POWERFUL MUSCLE SUPPORT

PWX compression improves power and endurance, while reducing muscle damage and fatigue.

2/ STAY WARM

Lightweight yet powerful brushed PWX fabric for greater warmth.

3/ TOTAL COMFORT

2XU jacquard waistband and premium, durable moisture-wicking yarns outlast the competition to keep the skin dry.

4/ NO SMELL

Antibacterial and anti-odour technology keeps you fresher for longer between washes, reducing your environmental footprint.

Recommended Activities Cold Weather Running or Team Sports.

Colours Available BLK/NRO.

Size Range XXS, XS, S, ST, M, MT, L, LT, XL, XLT, XXL, XXLT, XXXL.

Rise Regular. **Waistband** 5cm 2XU jacquard elastic.

Fit FIRM: 20-25 mmhg*

Fabric Front: PWX 70D Thermal: 75% Nylon, 25% Lycra.



WA6352b

THERMAL
MID-RISE
COMPRESSION
TIGHTS



1/ POWERFUL MUSCLE SUPPORT

PWX compression improves power and endurance, while reducing muscle damage and fatigue.

2/ STAY WARM

Lightweight yet powerful brushed PWX 70D Thermal fabric for greater warmth.

3/ TOTAL COMFORT

Mid-Rise power mesh waistband and premium, durable moisture-wicking yarns outlast the competition and keep the skin dry.

4/ NO SMELL

Antibacterial and anti-odour technology keeps you fresher for longer between washes, reducing your environmental footprint.

Recommended Activities Cold Weather Running or Team Sports.

Colours Available BLK/NRO.

Size Range XXS, XS, XST, S, ST, M, MT, L, LT, XL, XXL.

Rise Mid-Rise **Waistband** 8cm wide waistband.

Fit FIRM: 20-25 mmhg*

Fabric PWX 70D Thermal: 75% Nylon, 25% Lycra.

X

X

X



MA3021a / WA3022a

**THERMAL
COMPRESSION
LONG SLEEVE
TOP**



1/ POWERFUL MUSCLE SUPPORT

PWX compression improves power and endurance, while reducing muscle damage and fatigue.

2/ STAY WARM

Lightweight yet powerful brushed PWX fabric for greater warmth.

3/ TOTAL COMFORT

Premium, durable moisture-wicking yarns outlast the competition to keep the skin dry & comfortable.

4/ NO SMELL

Antibacterial and anti-odour technology keeps you fresher for longer between washes, reducing your environmental footprint.

Recommended Activities Cold Weather Running or Team Sports.

Colours Available BLK/BLK.

Size Range Men: XS, S, M, L, XL, XXL.

Women: XXS, XS, S, M, L, XL.

Fabric PWX 70D Thermal: 75% Nylon, 25% Lycra.

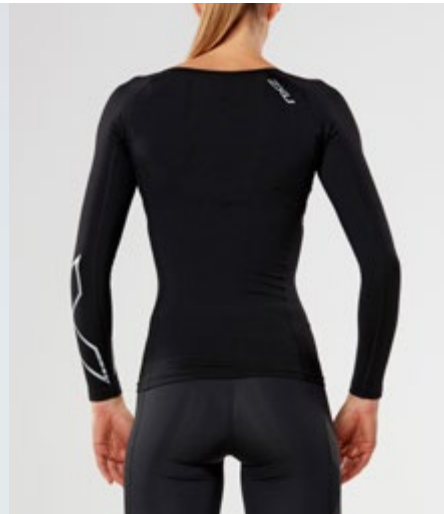

MA6311b / WA6312b

**WIND
DEFENCE
COMPRESSION
TIGHTS**



1/ STAY DRY

Advanced 20k/20k waterproof stretch membrane panels to withstand rain and showers.

2/ STAY WARM

Lightweight yet powerful brushed PWX 70D Thermal fabric for flexibility and greater warmth.

3/ ESSENTIAL STORAGE

Large rear zip pocket for phone storage.

4/ BE SEEN

Reflective logos for greater visibility in low-light conditions.

5/ NO SMELL

Antibacterial and anti-odour technology keeps you fresher for longer between washes, reducing your environmental footprint.

Recommended Activities Cold & Wet Weather Running.

Colours Available BLK/SSR.

Size Range Men: XXXS, XS, S, ST, M, MT, L, LT, XL, XLT, XXL, XXLT, XXXL.

Women: XXS, XS, XST, S, ST, M, MT, L, LT, XL, XXL.

Rise Regular. **Waistband** 3.5cm covered elastic with drawstring. **Fit FIRM:** 20-25 mmhg*

Fabric Front Membrane: 100% Polyester. Front/Rear: PWX 105D Thermal: 65% Nylon, 35% Lycra.

GHST WATERPROOF JACKET

Engineered from a lightweight waterproof stretch membrane, the GHST Waterproof Jacket provides serious protection from all the elements.

1/ STAY DRY

Advanced 20k/10k membrane with adjustable hood and taped seams offers serious protection from rain whilst still remaining breathable.

2/ TOTAL COMFORT

Raglan sleeves, adjustable hem & cuffs and a full front zip allow you to adjust airflow when the weather changes.

3/ ESSENTIAL STORAGE

Front zip hand pockets for storing cards or keys while you run.

4/ BE SEEN

Reflective logos / trims on arms and back provide 360 visibility in low-light conditions.

Product Code MR6204a / WR6205a

Recommended Activities Wet Weather Running.

Colours Available

Men: BLK/GRF, MXB/SRF. Women: BEW/WHT, BLK/GRF.

Size Range

Men: XS, S, M, L, XL, XXL. Women: XXS, XS, S, M, L, XL.

Fabric

Outer: 79% Nylon, 21% Elastane.

Internal: PU 2.5 Layer.



TWO TIMES YOU



RUN / 20



MR6206a / WR6207a

GHST
1/2 ZIP
LONG SLEEVE
TOP

1/ TOTAL COMFORT

Ribbed raglan sleeves provide maximum movement, a 1/2 zip design lets you adjust airflow, while slit thumb-holes on cuffs provide extra warmth on cooler days.

2/ STAY COOL

Quick-dry, lightweight moisture-wicking fabric pulls sweat away from the skin while mesh panels across back allow air to flow freely.

3/ BE SEEN

Reflective logos and colour hit through ribbed shoulder provide visibility in low-light conditions.

4/ NO SMELL

Antibacterial and anti-odour technology keeps you fresher for longer between washes, reducing your environmental footprint.

Recommended Activities Running.

Colours Available Men: BLK/WHT, POS/UAQ.

Women: BLK/WHT, ULT/WHT.

Size Range Men: XS, S, M, L, XL, XXL. Women: XXS, XS, S, M, L, XL.

Fabric Single Jersey: 88% Polyester, 12% Spandex. Mesh: 92% Polyester, 8% Spandex. Rib: 90% Polyester, 10% Spandex.

GARMENT FEATURES

- 1/2 zip long sleeve
- Stand collar
- Lightweight moisture-wicking jersey on front and arms
- Mesh back panel
- Two-tone ribbed shoulders
- Thumb-holes at sleeve cuffs
- Reflective logos and trims
- Antibacterial and anti-odour technology



MR6210a / WR6212a

GHST
SHORT SLEEVE
TEE

1/ ULTIMATE COOLING

Puffed high-filament polyester yarn blocks UV and provides rapid moisture dispersal to keep you cool and dry.

2/ TOTAL COMFORT

Super lightweight fabric and construction for a near-weightless performance.

3/ BE SEEN

Reflective logos & trims provide 360 visibility in low-light conditions.

4/ NO SMELL

Antibacterial and anti-odour technology keeps you fresher for longer between washes, reducing your environmental footprint.

Recommended Activities Running.

Colours Available

Men: BLK/GRF, MXA/BRF, MXB/SRF.

Women: BEU/WRF, BEW/WHT, BLK/GRF.

Size Range Men: XS, S, M, L, XL, XXL. Women: XXS, XS, S, M, L, XL.

Fabric X Lite Pro: 100% Polyester.

GARMENT FEATURES

- Set-in short sleeve tee
- Near-weightless 96gsm X LITE PRO fabric
- Reflective logos and trims
- Antibacterial and anti-odour technology

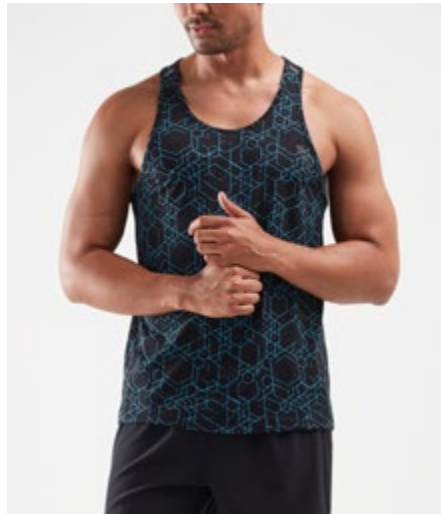

MR6211b / WR6213a

GHST SINGLET

1/ ULTIMATE COOLING

Puffed high-filament polyester yarn blocks UV and provides rapid moisture dispersal to keep you cool and dry.

2/ TOTAL COMFORT

Super lightweight fabric and construction for a near-weightless performance.

3/ BE SEEN

Reflective logos & trims provide 360 visibility in low-light conditions.

4/ NO SMELL

Antibacterial and anti-odour technology keeps you fresher for longer between washes, reducing your environmental footprint.

Recommended Activities Running.

Colours Available

Men: BLK/GRF, MXA/BRF, MXB/SRF.

Women: BEU/WRP, BEW/WHT, BLK/GRF.

Size Range Men: XS, S, M, L, XL, XXL. Women: XXS, XS, S, M, L, XL.

Fabric X Lite Pro: 100% Polyester.



MR6215b / WR6220b

GHST 3" SHORTS

1/ TOTAL COMFORT

Lightweight, breathable 4-way stretch knit outer and inner brief liner combine for ultimate flexibility in motion and comfort.

2/ ESSENTIAL STORAGE

A back zip pocket lets you safely store your phone, cards or keys.

3/ BE SEEN

Reflective logos & trims provide 360 visibility in low-light conditions.

4/ NO SMELL

Antibacterial and anti-odour technology keeps you fresher for longer between washes, reducing your environmental footprint.

Recommended Activities Running.

Colours Available BLK/BRF.

Size Range

Men: XS, S, M, L, XL, XXL.

Women: XXS, XS, S, M, L, XL.

Fabric 86% Polyester, 14% Spandex.

GARMENT FEATURES

- 3" short
- 4-way stretch knit outer
- Brief liner
- Jacquard elastic waistband with internal draw-cord
- Back zip pocket
- Bonded hems
- Reflective logo and trims
- Antibacterial and anti-odour technology on brief liner

X

X

MCS RUN COMPRESSION

The MCS Run Compression Collection is developed with a detailed understanding of the impact running has on the legs. Constructed with revolutionary Muscle Containment Stamping (MCS), muscle damage, movement & fatigue is minimised for your best run yet.

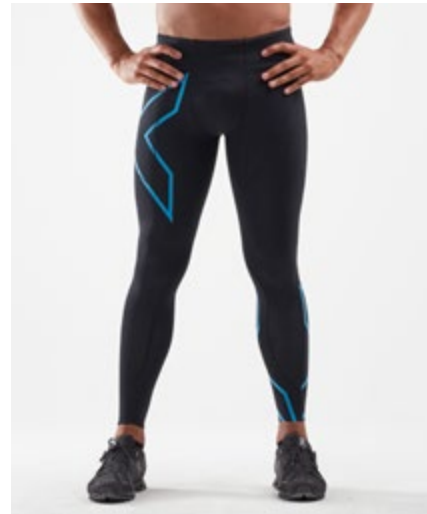

MA5305b / WA5332b
MCS RUN COMPRESSION TIGHTS

GARMENT FEATURES

- Full length compression tight
- Thigh/Quadriceps MCS reduces impact and dissipates the load transfer on the knee joint
- Calf/gastrocnemius MCS reduces muscle strain, especially during the toe phase of running, and reduced oscillation of the calf muscles
- PWX Flex 70D front panels and PWX Weight 105D back panels
- Drawstring waistband for adjustable secure fit
- Graduated compression for improved circulation
- Large pocket for phone and zip pocket for cards & keys
- Mesh pocket for gels and other items
- Reflective logos for greater visibility
- Flatlock seams to reduce chafe
- Antibacterial and anti-odour technology

Recommended Activities Running. **Colours Available** Men: BLK/BRF, BLK/GRF, BLK/UAF. Women: BLK/BRF, BLK/GRF, BLK/URF. **Size Range** Men: XXS-XXXL. Women: XXS-XXL. **Rise Regular** **Waistband** Men: 3.5cm covered elastic with drawstring. Women: 4cm covered elastic with drawstring. **Fit FIRM:** 20-30 mmhg* **Fabric** Front: Men: PWX 70D: 72% Nylon, 28% Lycra. Back: PWX 105D 65% Nylon, 35% Lycra. Women: PWX 70D: 72% Nylon, 28% Lycra. Back: PWX 160D 65% Nylon, 35% Lycra.

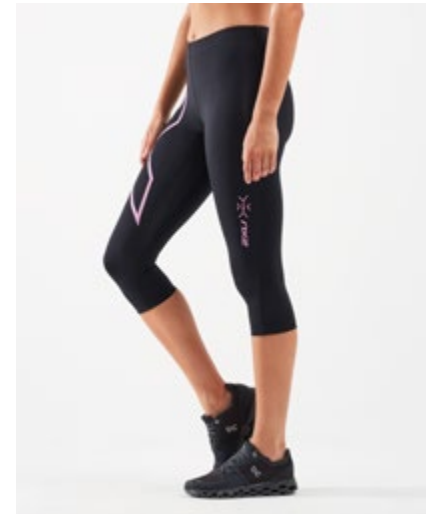

WA5333b
MCS RUN COMPRESSION 3/4 TIGHTS

GARMENT FEATURES

- 3/4 compression tight
- Thigh/Quadriceps MCS reduces impact and dissipates the load transfer on the knee joint
- PWX Flex 70D front panels and PWX Weight 160D back panels
- Drawstring waistband for adjustable secure fit
- Large pocket for phone
- Zip pocket for cards and keys
- Mesh pocket for gels and other items
- Reflective logos for greater visibility
- Flatlock seams to reduce chafe
- Antibacterial and anti-odour technology

Recommended Activities Running. **Colours Available** BLK/BRF, BLK/GRF, BLK/URF. **Size Range** XXS, XS, XST, S, ST, M, MT, L, LT, XL, XXL. **Rise Regular** **Waistband** 4cm covered elastic with drawstring. **Fit FIRM:** 20-25 mmhg* **Fabric** Front: PWX 70D 72% Nylon, 28% Lycra. Back: PWX 160D 65% Nylon, 35% Lycra.

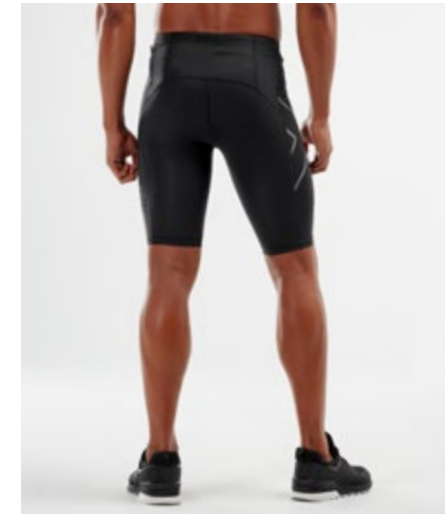

MA5331b / WA5334b
MCS RUN COMPRESSION SHORTS

GARMENT FEATURES

- Compression short
- Thigh/Quadriceps MCS reduces impact and dissipates the load transfer on the knee joint
- PWX Flex 70D front panels and PWX Weight 105D back panels
- Drawstring waistband for adjustable secure fit
- Large pocket for phone
- Zip pocket for cards and keys
- Mesh pocket for gels and other items
- Reflective logos for greater visibility
- Flatlock seams to reduce chafe
- Antibacterial and anti-odour technology

Recommended Activities Running. **Colours Available** Men: BLK/BRF, BLK/GRF, BLK/UAF. Women: BLK/GRF. **Size Range** Men: XXS, XS, S, M, L, XL, XXL, XXXL. Women: XXS, XS, S, M, L, XL, XXL. **Rise Regular** **Waistband** Men: 3.5cm covered elastic with drawstring. Women: 4cm covered elastic with drawstring. **Fit FIRM:** 20-25 mmhg* **Fabric** Men: Front: PWX 70D 72% Nylon, 28% Lycra. Back: PWX 105D 65% Nylon, 35% Lycra. Women: Front: PWX 70D 72% Nylon, 28% Lycra. Back: PWX 160D 65% Nylon, 35% Lycra.

X

X

X

XVENT DWR JACKET

Constructed from a water-resistant stretch woven fabric, the XVENT Durable Water Resistant Jacket has all the protection you need for those cooler runs at dawn or dusk.

1/ STAY DRY

Stretch woven shell with adjustable 3 piece hood and environmentally responsible C6 DWR treatment to withstand rain and showers.

2/ STAY COOL

Back vent with power mesh lining to enhance breathability and ventilation.

3/ ESSENTIAL STORAGE

Front zip hand pockets for storing cards or keys while you run.

4/ BE SEEN

Reflective logos / trims on shoulders provide 360 visibility in low-light conditions.

Product Code MR6235a / WR6309a

Recommended Activities Running.

Colours Available

Men: BLK/SRF, CHC/TRB.

Women: BLK/SRF, WHT/POS.

Size Range

Men: XS, S, M, L, XL, XXL.

Women: XXS, XS, S, M, L, XL.

Fabric

86% Polyester, 14% Spandex.



TWO TIMES YOU



RUN / 24



MR6372a / WR6374a

XVENT G2
LONG SLEEVE
TOP

1/ STAY COOL

Lightweight mesh fabric back panel engineered to enhance breathability and ventilation.

2/ STAY DRY

Moisture-wicking double-knit fabric delivers rapid moisture wicking to keep you dry.

3/ BE SEEN

Reflective logos & trims on shoulders, arms and back provide 360 visibility in low-light conditions.

4/ NO SMELL

Antibacterial and anti-odour technology keeps you fresher for longer between washes, reducing your environmental footprint.

Recommended Activities Running.

Colours Available

Men: BLK/SRF, CHC/SRF.

Women: BLK/SRF, PLT/SRF.

Size Range Men: XS, S, M, L, XL, XXL. Women: XXS, XS, S, M, L, XL.

Fabric Main: 47% Polyester, 53% Nylon. Mesh: 100% Polyester.

GARMENT FEATURES

- Long sleeve top
- Double-knit moisture-wicking fabric on front and arms
- Lightweight mesh back panel
- Reflective logos and trims
- Antibacterial and anti-odour technology



MR6373a / WR6375a

XVENT G2
SHORT SLEEVE
TEE

1/ STAY COOL

Lightweight mesh fabric back panel engineered to enhance breathability and ventilation.

2/ STAY DRY

Moisture-wicking double-knit fabric delivers rapid moisture wicking to keep you dry.

3/ BE SEEN

Reflective logos & trims on shoulders, arms and back provide 360 visibility in low-light conditions.

4/ NO SMELL

Antibacterial and anti-odour technology keeps you fresher for longer between washes, reducing your environmental footprint.

Recommended Activities Running.

Colours Available

Men: BLK/SRF, CHC/SRF, DSG/SRF, TRB/SRF, WHT/SRF.

Women: BLK/SRF, NMT/SRF, PLT/SRF, POS/SRF, WHT/SRF.

Size Range Men: XS, S, M, L, XL, XXL. Women: XXS, XS, S, M, L, XL.

Fabric Main: 47% Polyester, 53% Nylon. Mesh: 100% Polyester.

GARMENT FEATURES

- Short sleeve tee
- Double-knit moisture-wicking fabric on front and arms
- Lightweight mesh back panel
- Reflective logos and trims
- Antibacterial and anti-odour technology



MR6362a

**XVENT G2
TANK**

1/ STAY COOL

Lightweight mesh fabric back panel engineered to enhance breathability and ventilation.

2/ STAY DRY

Moisture-wicking double-knit fabric delivers rapid moisture wicking to keep you dry.

3/ BE SEEN

Reflective logos & trims on front and back provide 360 visibility in low-light conditions.

4/ NO SMELL

Antibacterial and anti-odour technology keeps you fresher for longer between washes, reducing your environmental footprint.

Recommended Activities Running.

Colours Available

BLK/SRF, CHC/SRF, DSG/SRF, TRB/SRF, WHT/SRF.

Size Range XS, S, M, L, XL, XXL.

Fabric Main: 47% Polyester, 53% Nylon. Mesh: 100% Polyester.

GARMENT FEATURES

- Tank
- Double-knit moisture-wicking fabric on front
- Lightweight mesh back panel
- Reflective logos and trims
- Antibacterial and anti-odour technology



WR6353a

**XVENT G2
SINGLET**

1/ STAY COOL

Lightweight mesh fabric back panel engineered to enhance breathability and ventilation.

2/ STAY DRY

Moisture-wicking double-knit fabric delivers rapid moisture wicking to keep you dry.

3/ BE SEEN

Reflective logos & trims on front and back provide 360 visibility in low-light conditions.

4/ NO SMELL

Antibacterial and anti-odour technology keeps you fresher for longer between washes, reducing your environmental footprint.

Recommended Activities Running.

Colours Available

BLK/SRF, NMT/SRF, PLT/SRF, POS/SRF, WHT/SRF.

Size Range XXS, XS, S, M, L, XL.

Fabric Main: 47% Polyester, 53% Nylon. Mesh: 100% Polyester.

GARMENT FEATURES

- Singlet
- Double-knit moisture-wicking fabric on front
- Lightweight mesh back panel
- Reflective logos and trims
- Antibacterial and anti-odour technology



MR6218b / WR6222b

XVENT
WOVEN
JOGGER

1/ STAY DRY

Lightweight stretch woven fabric delivers rapid moisture-wicking to keep you dry.

2/ TOTAL COMFORT

Ankle zips help adjust level of cooling and allow joggers to be easily removed over shoes.

3/ ESSENTIAL STORAGE

Zip pockets for storing cards or keys while you run.

4/ BE SEEN

Reflective logos/trims on the thigh and back of knees provide 360 visibility in low-light conditions.

Recommended Activities Running.
Colours Available BLK/SRF.
Size Range
Men: XS, S, M, L, XL, XXL.
Women: XXS, XS, S, M, L, XL.
Fabric 86% Polyester, 14% Spandex.



MR6241b

XVENT
2-IN-1
7" SHORT

1/ POWERFUL MUSCLE SUPPORT

PWX compression inner improves power and endurance, and reduces muscle damage and fatigue.

2/ STAY COOL

Lightweight stretch woven outer provides extra breathability.

3/ ESSENTIAL STORAGE

Easy-access phone pocket on compression inner, plus a zip pocket to secure valuables.

4/ NO SMELL

Antibacterial and anti-odour technology keeps you fresher for longer between washes, reducing your environmental footprint.

Recommended Activities Running.
Colours Available BLK/SRF.
Size Range
XS, S, M, L, XL, XXL.
Fabric Outer: 86% Polyester, 14% Spandex.
Inner: 72% Nylon, 28% Lycra.



MR6240b

XVENT
2-IN-1
5" SHORT

1/ POWERFUL MUSCLE SUPPORT

PWX compression inner improves power and endurance, and reduces muscle damage and fatigue.

2/ STAY COOL

Lightweight stretch woven outer provides extra breathability.

3/ ESSENTIAL STORAGE

Easy-access phone pocket on compression inner, plus a zip pocket to secure valuables.

4/ NO SMELL

Antibacterial and anti-odour technology keeps you fresher for longer between washes, reducing your environmental footprint.

Recommended Activities Running.
Colours Available BLK/SRF.
Size Range
XS, S, M, L, XL, XXL.
Fabric Outer: 86% Polyester, 14% Spandex.
Inner: 72% Nylon, 28% Lycra.



WR6221b

XVENT
2-IN-1
3" SHORT

1/ TOTAL COMFORT

Lightweight stretch woven fabric is flexible and moisture-wicking for ultimate comfort.

2/ ESSENTIAL STORAGE

A back zip pocket lets you safely store phone, cards or keys.

3/ BE SEEN

Reflective logos / trims on front and back hem provide 360 visibility in low-light conditions.

4/ NO SMELL

Antibacterial and anti-odour technology on brief liner keeps you fresher for longer between washes, reducing your environmental footprint.

Recommended Activities Running.
Colours Available BLK/SRF.
Size Range
XXS, XS, S, M, L, XL.
Fabric Outer: 86% Polyester, 14% Spandex.
Inner: 72% Nylon, 28% Lycra.

X

X

X

XVENT RUN SHORTS

Designed to be lightweight and flexible, the XVENT Run Short collection keeps you dry and cool so you can concentrate on your run.



MR6239b
XVENT
7" SHORT

GARMENT FEATURES

- 7" inseam
- Lightweight stretch woven
- Brief liner
- Elastic waistband with internal draw cord
- Back zip pocket
- Reflective logo and trims
- Antibacterial and anti-odour technology on brief liner

Recommended Activities Running.
Colours Available BLK/SRF, DSG/SRF, TRB/SRF.
Size Range XS, S, M, L, XL, XXL.
Fabric 86% Polyester, 14% Spandex.

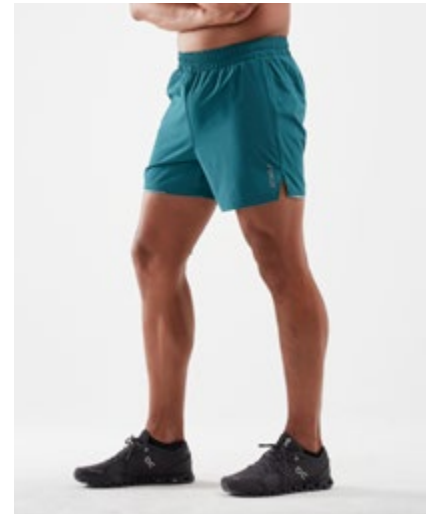

MR6238b
XVENT
5" SHORT

GARMENT FEATURES

- 5" inseam
- Lightweight stretch woven
- Brief liner
- Elastic waistband with internal draw cord
- Back zip pocket
- Reflective logo and trims
- Antibacterial and anti-odour technology on brief liner

Recommended Activities Running.
Colours Available BLK/SRF, DSG/SRF, TRB/SRF.
Size Range XS, S, M, L, XL, XXL.
Fabric 86% Polyester, 14% Spandex.



WR6219b
XVENT
4" SHORT

GARMENT FEATURES

- 4" inseam short
- Lightweight stretch woven
- Brief liner
- Comfortable knit waistband
- Back zip pocket
- Reflective logo and trims
- Antibacterial and anti-odour technology on brief liner

Recommended Activities Running.
Colours Available BLK/SRF, POS/SRF, TRB/SRF.
Size Range XXS, XS, S, M, L, XL.
Fabric 86% Polyester, 14% Spandex.

X

X

X



MA6067b / WA5988b

RUN DASH COMPRESSION TIGHTS

1/ GRADUATED COMPRESSION MESH

Boosts blood flow to muscles, improving performance, reducing risk of injury and speeding up recovery whilst PWX Mesh panels improve breathability to keep you at optimal performance temperature.

2/ ESSENTIAL STORAGE

Back pocket provide storage for phone, cards and keys.

3/ BE SEEN

Reflective logos on thigh and calf provide 360 visibility in low-light conditions.

4/ TOTAL COMFORT

High quality, durable, moisture-wicking yarns outlast the competition and keep the skin cool and dry.

5/ NO SMELL

Antibacterial and anti-odour technology keeps you fresher for longer between washes, reducing your environmental footprint.

Recommended Activities Running. **Colours Available** BLK/SRF.

Size Range Men: XXS, XS, S, ST, M, MT, L, LT, XL, XLT, XXL, XXLT, XXXL. Women: XXS, XS, XST, S, ST, M, MT, L, LT, XL, XXL.

Rise Men: Regular. Women: Mid-Rise. **Waistband** Men: 3.5cm covered elastic with drawstring. Women: 8cm wide waistband.

Fit Men: FIRM: 20-30 mmhg*. Women: FIRM: 20-25mmhg*. **Fabric** Men: Front: PWX Flex 70D: 75% Nylon, 25% Lycra. Back: PWX Weight 105D: 65% Nylon, 35% Lycra. Leg Panels: PWX Mesh 105D: 65% Nylon, 35% Lycra. Women: Front: PWX Flex 70D: 72% Nylon, 28% Lycra. Back: PWX Weight 160D: 65% Nylon, 35% Lycra. Leg Panels: PWX Mesh 105D: 65% Nylon, 35% Lycra.



WA5313b

RUN MID-RISE COMPRESSION 3/4 TIGHTS

GARMENT FEATURES

- 3/4 compression tight
- PWX Flex 70D front panels and PWX Weight 160D back panels
- Mid-rise power mesh waistband for body sculpting secure fit
- Large pocket for phone, cards and keys
- Reflective logos for greater visibility
- Flatlock seams to reduce chafe
- Antibacterial and anti-odour technology

Recommended Activities Running. **Colours Available** BLK/SRF.

Size Range XXS, XS, XST, S, ST, M, MT, L, LT, XL, XXL.

Rise Mid-Rise. **Waistband** 8cm wide waistband. **Fit** FIRM: 20-25mmhg*.

Fabric Front: PWX Flex 70D: 72% Nylon, 28% Lycra. Back: PWX Weight 160D: 65% Nylon, 35% Lycra.



MA6108b / WA6182b

RUN DASH COMPRESSION SHORTS

GARMENT FEATURES

- Compression short
- Ventilated PWX Mesh panels
- PWX Flex 70D upper front panels and PWX Weight 105D upper back panels
- Drawstring waistband for adjustable secure fit
- Large pocket for phone, cards and keys
- Reflective logos for greater visibility
- Flatlock seams to reduce chafe
- Antibacterial and anti-odour technology

Recommended Activities Running. **Colours Available** BLK/SRF. **Size Range**

Men: XS, S, M, L, XL, XXL, XXXL. Women: XXS, XS, S, M, L, XL. **Rise** Men: Regular. Women: Mid-Rise. **Waistband** Men: 3.5CM Covered Elastic with Drawstring. Women: 8CM Wide Waistband. **Fit** Men: Firm: 20-30 Mmhg*. Women: Firm: 20-25Mmhg*. **Fabric** Men: Front: PWX Flex 70D: 75% Nylon, 25% Lycra. Back: PWX Weight 105D: 65% Nylon, 35% Lycra. Leg Panels: PWX Mesh 105D: 65% Nylon, 35% Lycra. Women: Front: PWX Flex 70D: 72% Nylon, 28% Lycra. Back: PWX Weight 160D: 65% Nylon, 35% Lycra. Leg Panels: PWX Mesh 105D: 65% Nylon, 35% Lycra.

X

X

PERFORATED MEDIUM IMPACT BRA

Engineered to offer the ultimate in comfort and support during the toughest of workouts, the fully adjustable Perforated Medium Impact Bra ensures a fit for every fit.

1/ SUPPORT

Moulded cups provide coverage and support, no matter what the day throws at you.

2/ TOTAL COMFORT

Adjustable elastic straps and hook & eye closure on back ensures the perfect fit.

3/ STAY DRY

Breathable perforated fabric provides ventilation where you need it most.

Product Code WR6347a

Recommended Activities Training, HIIT, Spin.

Colours Available BLK/BLK, PLT/PLT.

Size Range XXS, XS, S, M, L, XL.

Fabric Main: 77% Nylon, 23% Spandex.

Power Mesh: 71% Polyamide, 29% Elastane.

Liner: 82% Polyester, 8% Elastane

PERFORM MEDIUM IMPACT CROP

Offering all-over support and coverage, the Perform Medium Impact Crop is an essential in any active wear set, providing everyday comfort, performance & style.

1/ MEDIUM IMPACT SUPPORT

Medium impact support with removable foam cups and key hole back with adjustable hook and eye closure.

2/ TOTAL COMFORT

Soft, elastic underbust band with racer back design allows full range of motion.

3/ STAY DRY

Moisture-wicking fabric with power mesh back panel and centre front splicing, increases breathability and keeps you dry throughout the toughest running, HIIT or spin sessions.

4/ NO SMELL

Antibacterial and anti-odour technology keeps you fresher for longer between washes, reducing your environmental footprint.

Product Code WR6376a

Recommended Activities Training, HIIT, Spin.

Colours Available BEP/POS, BLK/BLK.

Size Range XXS, XS, S, M, L, XL.

Fabric

BLK/BLK Main: 62% Polyamide, 38% Elastane.

Power Mesh: 71% Polyamide, 29% Elastane.

Liner: 88% Polyester, 12% Spandex.

BEP/POS Main: 72% Nylon, 28% Lycra.

Power Mesh: 71% Polyamide, 29% Elastane.

Liner: 88% Polyester, 12% Spandex.



TWO TIMES YOU



RUN / 31



WA5378b

**PRINT MID-RISE
COMPRESSION
TIGHTS**

1/ POWERFUL MUSCLE SUPPORT

Lightweight yet powerful PWX Flex 70D front panels heighten flexibility, whilst PWX Weight 160D back panels provide squat proof coverage.

2/ GRADUATED COMPRESSION

Boosts blood flow to muscles, improving performance, reducing risk of injury and speeding up recovery.

3/ TOTAL COMFORT

Durable, moisture-wicking yarns and power mesh waistband outlast the competition and keep the skin cool & dry.

4/ NO SMELL

Antibacterial and anti-odour technology keeps you fresh and odour free so you can wear more, wash less and reduce your environmental footprint.

Recommended Activities Running, Training, HIIT, Spin.

Colours Available BEP/NRO, CBN/BLK. **Size Range** XXS, XS, XST, S, ST, M, MT, L, LT, XL, XXL.

Rise Mid-Rise **Waistband** 8cm Power Mesh Comfort Band. **Fit** FIRM: 20-25 mmhg*

Fabric Front: PWX 70D 72% Nylon, 28% Lycra. Back: PWX 160D 65% Nylon, 35% Lycra.



WA2864b

**MID-RISE
COMPRESSION
TIGHTS**

GARMENT FEATURES

- Full length compression tight
- PWX Flex 70D front panels and PWX Weight 160D back panels
- Mid-rise power mesh waistband for body sculpting secure fit
- Graduated compression for improved circulation
- Flatlock seams to reduce chafe
- Antibacterial and anti-odour technology

Recommended Activities Running, Training, HIIT, Spin.

Colours Available BLK/DBK, BLK/DPL, BLK/DRF BLK/DSB, BLK/ZCX.

Size Range XXS, XS, XST, S, ST, M, MT, L, LT, XL, XXL.

Rise Mid-Rise **Waistband** 8cm Power Mesh Comfort Band.

Fit FIRM: 20-25 mmhg* **Fabric** Front: PWX 70D 72% Nylon, 28% Lycra. Back: PWX 160D 65% Nylon, 35% Lycra.



WA5660b

**PRINT MID-RISE
COMPRESSION
3/4 TIGHTS**

GARMENT FEATURES

- 3/4 length compression tight
- PWX Flex 70D front panels and PWX Weight 160D back panels
- Mid-rise power mesh waistband for body sculpting secure fit
- Flatlock seams to reduce chafe
- Antibacterial and anti-odour technology

Recommended Activities Running, Training, HIIT, Spin.

Colours Available BEP/NRO.

Size Range XXS, XS, XST, S, ST, M, MT, L, LT, XL, XXL.

Rise Mid-Rise **Waistband** 8cm Power Mesh Comfort Band.

Fit FIRM: 20-25 mmhg* **Fabric** Front: PWX 70D 72% Nylon, 28% Lycra. Back: PWX 160D 65% Nylon, 35% Lycra.

X

X

TRAINING COMPRESSION & APPAREL

Training isn't for one sole purpose. For many, it's the tool they use to be the best version of themselves. They know when their body is strong, their mind is strong. That strength allows them to make the most of each day.

Designed to withstand the toughest of workouts, The 2XU TRAIN collection is there to support you on your journey, no matter your finish line.



WR6258a

XCTRL
LONG SLEEVE
TOP

1/ STAY DRY

Moisture-wicking fabric with perforated back panel, keeps you dry throughout the toughest training sessions.

2/ TOTAL COMFORT

A relaxed neckline, raglan sleeves, longer length and side splits, provide freedom of movement and coverage when bending and stretching.

3/ BUILT TO LAST

Durable fabric and construction resists pilling and abrasion.

4/ NO SMELL

Antibacterial and anti-odour technology keeps you fresher for longer between washes, reducing your environmental footprint.

Recommended Activities Training, HIIT.

Colours Available

BLK/BLK, SWT/SWT.

Size Range XXS, XS, S, M, L, XL.

Fabric 88% Polyester, 12% Spandex.

GARMENT FEATURES

- Set in long sleeve top
- Durable moisture-wicking fabric on front and arms
- Perforate back panel
- Relaxed fit and longer length
- Antibacterial and anti-odour technology



MR6275a / WR6257a

XCTRL
SHORT SLEEVE
TEE

1/ STAY DRY

Moisture-wicking fabric with perforated back panel, keeps you dry throughout the toughest training sessions.

2/ TOTAL COMFORT

A relaxed neckline, raglan sleeves, longer length and side splits, provide freedom of movement and coverage when bending and stretching.

3/ BUILT TO LAST

Durable fabric and construction resists pilling and abrasion.

4/ NO SMELL

Antibacterial and anti-odour technology keeps you fresher for longer between washes, reducing your environmental footprint.

Recommended Activities Training, HIIT.

Colours Available

Men: GRM/BLK, POS/BLK, SLE/BLK. Women: BLK/BLK, SWT/SWT, ULT/ULT.

Size Range Men: XS, S, M, L, XL, XXL. Women: XXS, XS, S, M, L, XL.

Fabric Mens: 88% Polyester, 12% Spandex.

GARMENT FEATURES

- Raglan short sleeve
- Durable moisture-wicking fabric on front and arms
- Perforate back panel
- Relaxed fit and longer length
- Bonded bartacks
- Side splits at hem
- Antibacterial and anti-odour technology



MR6274a
XCTRL
TANK

1/ STAY DRY

Moisture-wicking fabric with perforated back panel, keeps you dry throughout the toughest training sessions.

2/ TOTAL COMFORT

A relaxed neckline, raglan sleeves, longer length and side splits, provide freedom of movement and coverage when bending and stretching.

3/ BUILT TO LAST

Durable fabric and construction resists pilling and abrasion.

4/ NO SMELL

Antibacterial and anti-odour technology keeps you fresher for longer between washes, reducing your environmental footprint.

Recommended Activities Training, HIIT.

Colours Available

GRM/BLK, POS/BLK, SLE/BLK.

Size Range XS, S, M, L, XL, XXL.

Fabric 88% Polyester, 12% Spandex.

GARMENT FEATURES

- Tank
- Durable moisture-wicking fabric on front
- Perforate back panel
- Relaxed fit and longer length
- Bonded bartacks
- Side splits at hem
- Antibacterial and anti-odour technology



WR6256a
XCTRL
MESH
SINGLET

1/ STAY DRY

Moisture-wicking fabric with perforated back panel, keeps you dry throughout the toughest training sessions.

2/ TOTAL COMFORT

A relaxed neckline and longer length provides freedom of movement and coverage when bending and stretching.

3/ BUILT TO LAST

Durable fabric and construction resists pilling and abrasion.

4/ NO SMELL

Antibacterial and anti-odour technology keeps you fresher for longer between washes, reducing your environmental footprint.

Recommended Activities Training, HIIT.

Colours Available

BLK/BLK, SWT/SWT, ULT/ULT.

Size Range XXS, XS, S, M, L, XL.

Fabric 88% Polyester, 12% Spandex.

GARMENT FEATURES

- Singlet
- Durable moisture-wicking perforated fabric
- Relaxed fit and longer length
- Antibacterial and anti-odour technology

ACTIVE MEDIUM IMPACT CROP

Ideal for short-distance running, training and yoga, the Active Medium Impact Crop is designed to support, keeping you comfortable.

1/ TOTAL COMFORT

Power Mesh for ventilation and comfort.

2/ MILD SUPPORT

Interlock fabric provides coverage and support.

3/ BUILT TO LAST

Durable Nylon yarn resists pilling and abrasion.

4/ NO SMELL

Antibacterial and anti-odour technology keeps you fresher for longer between washes, reducing your environmental footprint.

Product Code WR6407a

Recommended Activities

Running and Training

Colours Available

BLK/TCL, BLK/ZCX.

Size Range

XXS, XS, S, M, L, XL.

Fabric

PWX: 72% Nylon, 28% Lycra.

Power Mesh: 71% Polyamide FD, 29% Elastane.



TWO TIMES YOU

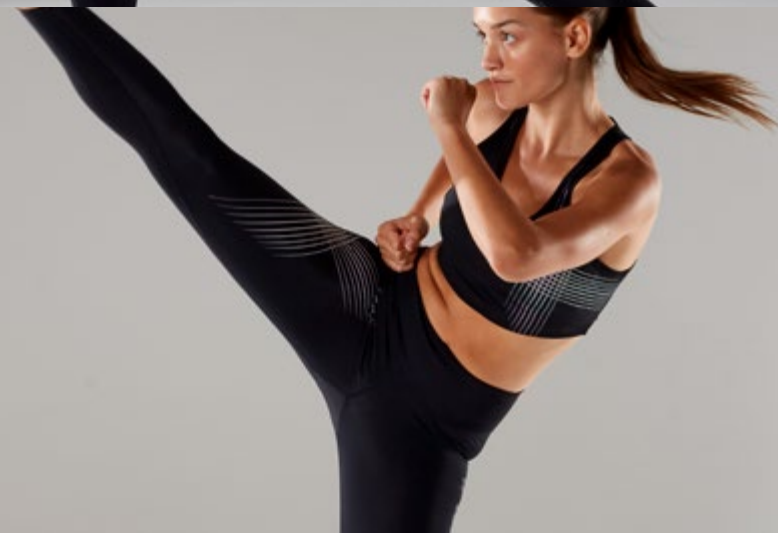

TRAINING / 36

MCS X-TRAIN COMPRESSION

The MCS Cross Training compression range is the ultimate training partner. Developed with a detailed understanding of the key muscles and movements used during high-intensity training, these tights reduce muscle movement, damage and fatigue so you can smash your goals at every workout.



MA5365b / WA5367b
MCS X-TRAIN COMPRESSION TIGHTS

GARMENT FEATURES

- MCS mapping targets the glutes, hamstrings, quadriceps and calves to reduce strain and muscle soreness
- Compression support to entire leg with PWX Flex 70D front panels and PWX Weight 105D back panels for coverage in the right places
- Graduated compression increases circulation for improved recovery and reduced muscle stiffness post-exercise
- Flexible waistband for comfort and extended wear
- Flatlock seams to reduce chafe
- Moisture-wicking to keep you cool and dry
- Antibacterial and anti-odour

Recommended Activities Training, HIIT.
Colours Available BLK/GLD, BLK/NRO. **Size Range** Men: XXS, XS, S, ST, M, MT, L, LT, XL, XLT, XXL, XXLT, XXXL. Women: XXS, XS, S, ST, M, MT, L, LT, XL, XL. **Rise** Men: Regular. Women: Mid-Rise. **Waistband** Men: 5CM 2XU Jacquard Elastic. Women: 8CM bonded flat waistband. **Fit FIRM:** 20-30 mmhg* **Fabric** Men: Front: PWX 70D 72% Nylon, 28% Elastane (Invista Lycra®). Back: PWX 105D 65% Nylon, 35% (Invista Lycra®). Women: Front: PWX 70D 72% Nylon, 28% Elastane (Invista Lycra®). Back: PWX 160D 72% Nylon, 28% (Invista Lycra®).



WA5368b
MCS X-TRAIN MID RISE COMPRESSION 3/4 TIGHTS

GARMENT FEATURES

- MCS mapping targets the glutes, hamstrings and quadriceps to help reduce strain and muscle soreness
- PWX 70D front panel for heightened flexibility and PWX 160D back panel for greater coverage
- Sleek, bonded waistband
- Flatlock seams to reduce chafe
- Moisture-wicking to keep you cool and dry
- Antibacterial and anti-odour

Recommended Activities Training, HIIT.
Colours Available BLK/GLD, BLK/NRO.
Size Range XXS, XS, XST, S, ST, M, MT, L, LT, XL, XXL
Rise Mid-Rise **Waistband** 8CM bonded flat waistband.
Fit FIRM: 20-30 mmhg* **Fabric** Front: PWX 70D 72% Nylon, 28% Elastane (Invista Lycra®). Back: PWX 160D 72% Nylon, 28% (Invista Lycra®).



MA5366b
MCS X-TRAIN COMPRESSION SHORTS

GARMENT FEATURES

- MCS mapping targets the glutes, hamstrings and quadriceps to help reduce strain and muscle soreness
- Compression support to upper leg with PWX Flex 70D front panels and PWX Weight 105D back panels
- 2XU jacquard waistband for greater comfort when worn as a base layer
- Flatlock seams to reduce chafe
- Moisture-wicking to keep you cool and dry
- Antibacterial and anti-odour

Recommended Activities Training, HIIT.
Colours Available BLK/GLD.
Size Range XXS, XS, S, M, L, XL, XXL, XXXL.
Rise Regular **Waistband** 5CM 2XU Jacquard elastic.
Fabric Front: PWX 70D 72% Nylon, 28% Elastane (Invista Lycra®). Back: PWX 105D 65% Nylon, 35% Elastane (Invista Lycra®).

X

X

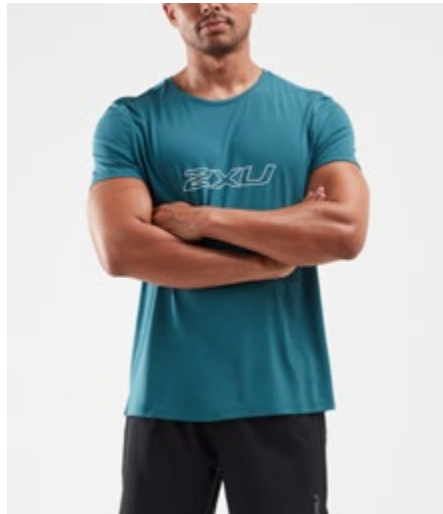

MR6243a / WR6296a

**CONTENDER
SHORT SLEEVE
TEE**

1/ STAY DRY

Quick-drying technology keeps you dry throughout the toughest training sessions.

2/ TOTAL COMFORT

A relaxed neckline, forward shoulder seams, longer length and side splits, provide freedom of movement and coverage when bending and stretching.

3/ NO SMELL

Antibacterial and anti-odour technology keeps you fresher for longer between washes, reducing your environmental footprint.

Recommended Activities Training, HIIT, Cold Weather Activity.

Colours Available Men: BLK/WHT, DSG/WHT, WHT/BLK.

Women: BLK/BLK, PLT/BMC, GRM/GEO.

Size Range Men: XS, S, M, L, XL, XXL. Women: XXS, XS, S, M, L, XL.

Fabric 62% Viscose, 33% Polyester, 5% Spandex.



MR6245a

**CONTENDER
TANK**

1/ STAY DRY

Quick-drying technology keeps you dry throughout the toughest training sessions.

2/ TOTAL COMFORT

A relaxed neckline, forward shoulder seams, longer length and side splits, provide freedom of movement and coverage when bending and stretching.

3/ NO SMELL

Antibacterial and anti-odour technology keeps you fresher for longer between washes, reducing your environmental footprint.

Recommended Activities Training, HIIT.

Colours Available BLK/WHT, DSG/WHT, WHT/BLK.

Size Range XS, S, M, L, XL, XXL.

Fabric 62% Viscose, 33% Polyester, 5% Spandex.

X

X

X



WR6297a

**CONTENDER
SINGLET**

1/ STAY DRY

Quick-drying technology keeps you dry throughout the toughest training sessions.

2/ TOTAL COMFORT

A relaxed neckline, forward shoulder seams, longer length and side splits, provide freedom of movement and coverage when bending and stretching.

3/ NO SMELL

Antibacterial and anti-odour technology keeps you fresher for longer between washes, reducing your environmental footprint.

Recommended Activities Training, HIIT, Spin.
Colours Available BLK/BLK, PLT/BMC, GRM/GEO.
Size Range XS, S, M, L, XL.
Fabric 62% Viscose, 33% Polyester, 5% Spandex.

GARMENT FEATURES

- Relaxed singlet fit
- Natural cotton hand feel fabric with quick-dry technology
- Side splits at hem
- 2XU front chest graphic



WR6259a

**CONTENDER
CROP TANK**

1/ STAY DRY

Quick-drying technology keeps you dry throughout the toughest training sessions.

2/ TOTAL COMFORT

A relaxed neckline, forward shoulder seams, longer length and side splits, provide freedom of movement and coverage when bending and stretching.

3/ NO SMELL

Antibacterial and anti-odour technology keeps you fresher for longer between washes, reducing your environmental footprint.

Recommended Activities Training, HIIT, Spin.
Colours Available BLK/BLK, PLT/BMC, GRM/GEO.
Size Range XS, S, M, L, XL.
Fabric 62% Viscose, 33% Polyester, 5% Spandex.

GARMENT FEATURES

- Relaxed tank fit
- Natural cotton hand feel fabric with quick-dry technology
- Side splits at hem
- 2XU front chest graphic

X

X



WA6357b

**PRINT HI-RISE
COMPRESSION
TIGHTS**

1/ POWERFUL MUSCLE SUPPORT

Lightweight yet powerful PWX Flex 70D front panels heighten flexibility, whilst PWX Weight 160D back panels provide squat proof coverage.

2/ GRADUATED COMPRESSION

Boosts blood flow to muscles, improving performance, reducing risk of injury and speeding up recovery.

3/ TOTAL COMFORT

Extra high figure flattering, slimming and secure waistband combined with high quality, durable, moisture-wicking yarns outlast the competition and keep the skin cool and dry.

4/ NO SMELL

Antibacterial and anti-odour technology keeps you fresh and odour free so you can wear more, wash less and reduce your environmental footprint.

Recommended Activities Training, HIIT, Spin.

Colours Available CBN/BLK.

Size Range XXS, XS, XST, S, ST, M, MT, L, LT, XL, XXL.

Rise Hi-Rise. **Waistband** 12CM Waistband.

Fit FIRM: 20-25 mmHg*.

Fabric Front: PWX 70D 72% Nylon, 28% Lycra.

Back: PWX 160D 72% Nylon, 28% Lycra.

GARMENT FEATURES

- Full length compression tight
- PWX Flex 70D front panels and PWX Weight 160D back panels
- Hi-rise figure flattering, slimming and secure fit waistband
- Graduated compression for improved circulation
- Flatlock seams to reduce chafe
- Antibacterial and anti-odour technology



WA5380b

**HI-RISE
COMPRESSION
TIGHTS**

1/ POWERFUL MUSCLE SUPPORT

Lightweight yet powerful PWX Flex 70D front panels heighten flexibility, whilst PWX Weight 160D back panels provide squat proof coverage.

2/ GRADUATED COMPRESSION

Boosts blood flow to muscles, improving performance, reducing risk of injury and speeding up recovery.

3/ TOTAL COMFORT

Extra high figure flattering, slimming and secure waistband combined with high quality, durable, moisture-wicking yarns outlast the competition and keep the skin cool and dry.

4/ NO SMELL

Antibacterial and anti-odour technology keeps you fresh and odour free so you can wear more, wash less and reduce your environmental footprint.

Recommended Activities Training, HIIT, Spin.

Colours Available BLK/TCL, BLK/NRO.

Size Range XXS, XS, XST, S, ST, M, MT, L, LT, XL, XXL.

Rise Hi-Rise. **Waistband** 12CM Waistband.

Fit FIRM: 20-25 mmHg*.

Fabric Front: PWX 70D 72% Nylon, 28% Lycra.

Back: PWX 160D 72% Nylon, 28% Lycra.

X

X

X



WA5378b

**PRINT MID-RISE
COMPRESSION
TIGHTS**

1/ POWERFUL MUSCLE SUPPORT

Lightweight yet powerful PWX Flex 70D front panels heighten flexibility, whilst PWX Weight 160D back panels provide squat proof coverage.

2/ GRADUATED COMPRESSION

Boosts blood flow to muscles, improving performance, reducing risk of injury and speeding up recovery.

3/ TOTAL COMFORT

Mid-rise power mesh waistband for body sculpting secure fit combined with high quality, durable, moisture-wicking yarns outlast the competition and keep the skin cool and dry.

4/ NO SMELL

Antibacterial and anti-odour technology keeps you fresh and odour free so you can wear more, wash less and reduce your environmental footprint.

Recommended Activities Running, Training, HIIT.

Colours Available BEP/NRO, CBN/BLK.

Size Range XXS, XS, XST, S, ST, M, MT, L, LT, XL, XXL.

Rise Mid-Rise. **Waistband** 8CM Comfort Band with Powermesh.

Fit FIRM: 20-25 mmhg*. **Fabric** Front: PWX 70D 72% Nylon, 28% Lycra. Back: PWX 160D 72% Nylon, 28% Lycra.

GARMENT FEATURES

- Full length compression tight
- PWX Flex 70D front panels and PWX Weight 160D back panels
- Mid-rise power mesh waistband for body sculpting secure fit
- Graduated compression for improved circulation
- Flatlock seams to reduce chafe
- Antibacterial and anti-odour technology



WA2864b

**MID-RISE
COMPRESSION
TIGHTS**

1/ POWERFUL MUSCLE SUPPORT

Lightweight yet powerful PWX Flex 70D front panels heighten flexibility, whilst PWX Weight 160D back panels provide squat proof coverage.

2/ GRADUATED COMPRESSION

Boosts blood flow to muscles, improving performance, reducing risk of injury and speeding up recovery.

3/ TOTAL COMFORT

Mid-rise power mesh waistband for body sculpting secure fit combined with high quality, durable, moisture-wicking yarns outlast the competition and keep the skin cool and dry.

4/ NO SMELL

Antibacterial and anti-odour technology keeps you fresh and odour free so you can wear more, wash less and reduce your environmental footprint.

Recommended Activities Running, Training, HIIT.

Colours Available BLK/DBK, BLK/DPL, BLK/DRF, BLK/DSB, BLK/ZCX.

Size Range XXS, XS, XST, S, ST, M, MT, L, LT, XL, XXL.

Rise Mid-Rise. **Waistband** 8CM Comfort Band With Powermesh.

Fit FIRM: 20-25 mmhg*. **Fabric** Front: PWX 70D 72% Nylon, 28% Lycra. Back: PWX 160D 72% Nylon, 28% Lycra.

X

X

X



WA3516b

**MID-RISE
COMPRESSION
7/8 TIGHTS**

1/ POWERFUL MUSCLE SUPPORT

Lightweight yet powerful PWX Flex 70D front panels heighten flexibility, whilst PWX Weight 160D back panels provide squat proof coverage.

2/ MORE WEAR, LESS TEAR:

Durable yarns that outlast the competition

3/ TOTAL COMFORT:

Mid-rise power mesh waistband for body sculpting secure fit combined with high quality, durable, moisture-wicking yarns outlast the competition and keep the skin cool and dry.

4/ NO SMELL

Antibacterial and anti-odour technology keeps you fresh and odour free so you can wear more, wash less and reduce your environmental footprint.

Recommended Activities Running, Training, HIIT.

Colours Available BLK/DBK, BLK/DRF.

Size Range XXS, XS, XST, S, ST, M, MT, L, LT, XL, XXL.

Rise Mid-Rise. **Waistband** 8CM Comfort Band with Powermesh.

Fit FIRM: 20-25 mmhg*. **Fabric** Front: PWX 70D 72% Nylon, 28% Lycra. Back: PWX 160D 72% Nylon, 28% Lycra.

GARMENT FEATURES

- 7/8 compression tight
- PWX Flex 70D front panels and PWX Weight 160D back panels
- Mid-rise power mesh waistband for body sculpting secure fit
- Flatlock seams to reduce chafe
- Antibacterial and anti-odour technology

WA3027b

**MID-RISE
COMPRESSION
SHORTS**

1/ POWERFUL MUSCLE SUPPORT

Lightweight yet powerful PWX Flex 70D front panels heighten flexibility, whilst PWX Weight 160D back panels provide squat proof coverage.

2/ MORE WEAR, LESS TEAR:

Durable yarns that outlast the competition

3/ TOTAL COMFORT:

Mid-rise power mesh waistband for body sculpting secure fit combined with high quality, durable, moisture-wicking yarns outlast the competition and keep the skin cool and dry.

4/ NO SMELL

Antibacterial and anti-odour technology keeps you fresh and odour free so you can wear more, wash less and reduce your environmental footprint.

Recommended Activities Running, Training, HIIT.

Colours Available BLK/DBK.

Size Range XXS, XS, XST, S, ST, M, MT, L, LT, XL, XXL.

Rise Mid-Rise. **Waistband** 8CM Comfort Band with Powermesh.

Fabric Front: PWX 70D 72% Nylon, 28% Lycra.

Back: PWX 160D 72% Nylon, 28% Lycra.

X

X

X



MR6280b

XCTRL
7" SHORTS

1/ TOTAL COMFORT

Lightweight stretch woven with splits at side hem and adjustable elastic waistband provides freedom of movement and maximum comfort.

2/ STAY DRY

Perforated moisture-wicking fabric keeps you dry throughout the toughest training sessions.

3/ ESSENTIAL STORAGE

Front side pockets for secure storage.

4/ NO SMELL

Antibacterial and anti-odour technology keeps you fresher for longer between washes, reducing your environmental footprint.

Recommended Activities Training, HIIT.

Colours Available BLK/BLK, POS/BLK.

Size Range XS, S, M, L, XL, XXL.

Fabric 86% Polyester, 14% Spandex

GARMENT FEATURES

- 7" short
- Perforated lightweight stretch woven
- Elastic waistband with internal draw cord
- Front side pockets
- Bonded bartacks detailing



MR6279b

XCTRL
5" SHORTS

1/ TOTAL COMFORT

Lightweight stretch woven with splits at side hem and adjustable elastic waistband provides freedom of movement and maximum comfort.

2/ STAY DRY

Perforated moisture-wicking fabric keeps you dry throughout the toughest training sessions.

3/ ESSENTIAL STORAGE

Front side pockets for secure storage.

4/ NO SMELL

Antibacterial and anti-odour technology keeps you fresher for longer between washes, reducing your environmental footprint.

Recommended Activities Training, HIIT.

Colours Available BLK/BLK, POS/BLK.

Size Range XS, S, M, L, XL, XXL.

Fabric 86% Polyester, 14% Spandex

GARMENT FEATURES

- 5" short
- Perforated lightweight stretch woven
- Elastic waistband with internal draw cord
- Front side pockets
- Bonded bartacks detailing

X

X



MA5684b

**ACCELERATE
COMPRESSION
TIGHTS**

1/POWERFUL MUSCLE SUPPORT

Lightweight yet powerful PWX fabric reduces muscle movement, damage and fatigue.

2/ GRADUATED COMPRESSION:

Boosts blood flow to muscles, improving performance, reducing risk of injury and speeding up recovery.

3/ TOTAL COMFORT

Mesh gusset for improved breathability when layered under shorts and flat jacquard waistband combined with high quality, durable, moisture-wicking yarns outlast the competition and keep the skin cool and dry.

4/ ESSENTIAL STORAGE

A side pocket on the thigh offers a bounce-free solution for securing cards, keys or phone.

5/ NO SMELL

Antibacterial and anti-odour technology keeps you fresher for longer between washes, reducing your environmental footprint.

Recommended Activities Training, HIIT.

Colours Available BLK/NRO, TRB/NRO.

Size Range XS, S, ST, M, MT, L, LT, XL, XLT, XXL, XXXL.

Rise Regular **Waistband** 5cm 2XU Jacquard Elastic. **Fit** FIRM: 20-25 mmhg*

Fabric Front: PWX 70D 72% Nylon, 28% Elastane (Invista Lycra®).

Back: PWX 105D 65% Nylon, 35% Elastane (Invista Lycra®).

GARMENT FEATURES

- Full length compression tight
- PWX Flex 70D front panels and PWX Weight 105D back panels
- Flat jacquard waistband
- Graduated compression for improved circulation
- Mesh gusset for improved breathability
- Side pocket for phone, cards and keys
- Flatlock seams to reduce chafe
- Antibacterial and anti-odour technology



MA6356b

**ACCELERATE
COMPRESSION
SHORTS**

1/ POWERFUL MUSCLE SUPPORT

Lightweight yet powerful PWX fabric reduces muscle movement, damage and fatigue.

2/ TOTAL COMFORT

Mesh gusset for improved breathability when layered under shorts and flat jacquard waistband combined with high quality, durable, moisture-wicking yarns outlast the competition and keep the skin cool and dry.

3/ ESSENTIAL STORAGE

A side pocket on the thigh offers a bounce-free solution for securing cards, keys or phone.

4/ NO SMELL

Antibacterial and anti-odour technology keeps you fresher for longer between washes, reducing your environmental footprint.

Recommended Activities Training, HIIT.

Colours Available BLK/NRO, TRB/NRO.

Size Range XS, S, ST, M, MT, L, LT, XL, XLT, XXL, XXXL.

Rise Regular **Waistband** 5cm 2XU Jacquard Elastic.

Fabric Front: PWX 70D 72% Nylon, 28% Elastane (Invista Lycra®).

Back: PWX 105D 65% Nylon, 35% Elastane (Invista Lycra®).

GARMENT FEATURES

- Compression short
- PWX Flex 70D front panels and PWX Weight 105D back panels
- Flat jacquard waistband
- Mesh gusset for improved breathability
- Side pocket for phone, cards and keys
- Flatlock seams to reduce chafe
- Antibacterial and anti-odour technology

ACTIVE LONGLINE MEDIUM IMPACT CROP

Lightweight, breathable and flexible, the Active Medium Impact Crop provides all-over coverage and light support. Ideal for yoga, jogging and low impact training.

1/ LOW IMPACT SUPPORT

Low impact support with removable foam cups and full-coverage front.

2/ TOTAL COMFORT

Longline design with criss cross back strap provides freedom of movement, support and coverage for all-day wear.

3/ STAY DRY

Moisture-wicking fabric and open back design keeps you dry.

4/ NO SMELL

Antibacterial and anti-odour technology keeps you fresher for longer between washes, reducing your environmental footprint.

Product Code WR6299a

Recommended Activities Training, Ball Sports, Running.

Colours Available GEO/WHT, BMC/POS.

Size Range XXS, XS, S, M, L, XL.

Fabric Main: 62% Polyamide, 38% Elastane.

Power Mesh: 71% Polyamide, 29% Elastane.



TWO TIMES YOU



TRAINING / 45



WA6310b

**FITNESS
HI-RISE STRIDE
COMPRESSION
TIGHTS**

1/ LUXE FEEL

Ultra matte, anti-pill fabric smooths and sculpts for a luxe look every time.

2/ GRADUATED COMPRESSION

Mild graduated compression fit for improved circulation and recovery.

3/ TOTAL COMFORT

Barely-there feel, and supportive high waistband allows you to stay comfortable all day.

4/ NO SMELL

Antibacterial and anti-odour technology keeps you fresher for longer between washes, reducing your environmental footprint.

Recommended Activities Training, Ball Sports, Running.

Colours Available POS/BMC.

Size Range XXS, XS, XST, S, ST, M, MT, L, LT, XL, XXL.

Rise Hi-Rise **Waistband** 12CM Waistband. **Fit** MODERATE: 15-20 mmhg*

Fabric Interlock 62% Polyamide, 38% Elastane.

GARMENT FEATURES

- Mild compression support with comfortable fit for all-day wear.
- Graduated compression increases blood circulation for improved performance.
- 12CM comfort wide waistband.
- Contoured panels for a flattering shape.
- Body-sculpting full-coverage fabric for a smooth streamlined fit.
- Flatlock seams to reduce chafe.
- Antibacterial and anti-odour technology



WA6110b

**FITNESS
NEW HEIGHTS
COMPRESSION
TIGHTS**

1/ LUXE FEEL

Ultra matte, anti-pill fabric smooths and sculpts for a luxe look every time.

2/ GRADUATED COMPRESSION

Mild graduated compression fit for improved circulation and recovery.

3/ TOTAL COMFORT

Barely-there feel, and supportive high waistband allows you to stay comfortable all day.

4/ NO SMELL

Antibacterial and anti-odour technology keeps you fresher for longer between washes, reducing your environmental footprint.

Recommended Activities Yoga, Pilates, Gym

Colours Available BLK/WHT, CYM/WHT, EBC/BOL.

Size Range XXS, XS, XST, S, ST, M, MT, L, LT, XL, XXL.

Rise Hi-Rise **Waistband** 12CM waistband. **Fit** MODERATE: 15-20 mmhg*

Fabric Interlock 62% Polyamide, 38% Elastane.

GARMENT FEATURES

- Mild compression support with comfortable fit for all-day wear.
- Graduated compression increases blood circulation for improved performance.
- 12CM comfort wide waistband.
- Contoured panels for a flattering shape.
- Body-sculpting full-coverage fabric for a smooth streamlined fit.
- Flatlock seams to reduce chafe.
- Antibacterial and anti-odour technology



WA5657b

**PRINT
FITNESS HI-RISE
COMPRESSION
TIGHTS**

1/ LUXE FEEL

Ultra matte, anti-pill fabric smooths and sculpts for a luxe look every time.

2/ GRADUATED COMPRESSION

Mild graduated compression fit for improved circulation and recovery.

3/ TOTAL COMFORT

Barely-there feel, and supportive high waistband allows you to stay comfortable all day.

4/ NO SMELL

Antibacterial and anti-odour technology keeps you fresher for longer between washes, reducing your environmental footprint.

Recommended Activities Yoga, Pilates, Gym.

Colours Available BMC/POS.

Size Range XXS, XS, XST, S, ST, M, MT, L, LT, XL, XXL.

Rise Hi-Rise **Waistband** 12CM comfort waistband.

Fit MODERATE: 15-20 mmhg*

Fabric Interlock 62% Polyamide, 38% Elastane.



WA5382b

**FITNESS HI-RISE
COMPRESSION
TIGHTS**

GARMENT FEATURES

- Mild compression support with comfortable fit for all-day wear.
- Graduated compression increases blood circulation for improved performance.
- 12CM comfort wide waistband.
- Contoured panels for a flattering shape.
- Body-sculpting full-coverage fabric for a smooth streamlined fit.
- Flatlock seams to reduce chafe.
- Antibacterial and anti-odour technology

Recommended Activities Yoga, Pilates, Gym.

Colours Available BLK/BLK.

Size Range XXS, XS, XST, S, ST, M, MT, L, LT, XL, XXL.

Rise Hi-Rise **Waistband** 12CM comfort waistband.

Fit MODERATE: 15-20 mmhg*

Fabric Interlock 62% Polyamide, 38% Elastane.



WA5383b

**FITNESS HI-RISE
COMPRESSION
7/8 TIGHTS**

GARMENT FEATURES

- Mild compression support with comfortable fit for all-day wear.
- 12CM comfort wide waistband.
- Contoured panels for a flattering shape.
- Body-sculpting full-coverage fabric for a smooth streamlined fit.
- Flatlock seams to reduce chafe.
- Antibacterial and anti-odour technology

Recommended Activities Yoga, Pilates, Gym.

Colours Available BLK/BLK.

Size Range XXS, XS, XST, S, ST, M, MT, L, LT, XL, XXL.

Rise Hi-Rise **Waistband** 12CM comfort waistband.

Fit MODERATE: 15-20 mmhg*

Fabric Interlock 62% Polyamide, 38% Elastane.

X

X

X



WA6161b

**FITNESS
NEW HEIGHTS
COMPRESSION
BIKE SHORTS**

1/ LUXE FEEL

Ultra matte, anti-pill fabric smooths and sculpts for a luxe look every time.

2/ TOTAL COMFORT

Barely-there feel, and supportive high waistband allows you to stay comfortable all day.

3/ NO SMELL

Antibacterial and anti-odour technology keeps you fresher for longer between washes, reducing your environmental footprint.

Recommended Activities Training, Ball Sports, Running.

Colours Available BLK/BLK, CYM/CYM, EBC/BOL.

Size Range XXS, XS, S, M, L, XL, XXL.

Rise Hi-Rise **Waistband** 12CM comfort waistband.

Fabric Interlock 62% Polyamide, 38% Elastane.

GARMENT FEATURES

- Mild compression support with comfortable fit for all-day wear.
- Large side pocket for phone and essentials.
- 12CM comfort wide waistband.
- Contoured panels for a flattering shape.
- Body-sculpting full-coverage fabric for a smooth streamlined fit.
- 3D 2XU logo detail.
- Flatlock seams to reduce chafe.
- Antibacterial and anti-odour technology

WA5989b

**FITNESS
MID-RISE LINE UP
COMPRESSION
TIGHTS**

1/ LUXE FEEL

Ultra matte, anti-pill fabric smooths and sculpts for a luxe look every time.

2/ GRADUATED COMPRESSION

Mild graduated compression fit for improved circulation and recovery.

3/ TOTAL COMFORT

Barely-there feel, and supportive waistband allows you to stay comfortable all day.

4/ NO SMELL

Antibacterial and anti-odour technology keeps you fresher for longer between washes, reducing your environmental footprint.

Recommended Activities Training, HIIT.

Colours Available BLK/GEO.

Size Range XXS, XS, XST, S, ST, M, MT, L, LT, XL, XXL.

Rise Mid Rise. **Waistband** 8CM comfort waistband.

Fit Moderate: 15-20 Mmhg*.

Fabric Interlock 62% Polyamide, 38% Elastane.

GARMENT FEATURES

- Mild compression support with comfortable fit for all-day wear.
- Graduated compression increases blood circulation for improved performance.
- Comfortable 8CM wide waistband for extended wear.
- Contoured panels for a flattering shape.
- Body-sculpting full-coverage fabric for a smooth streamlined fit.
- Antibacterial and anti-odour technology

X

X



WA4177b

**FITNESS
COMPRESSION
TIGHTS**

GARMENT FEATURES

- Mild compression support with comfortable fit for all-day wear.
- Graduated compression increases blood circulation for improved performance.
- Comfortable 8CM wide waistband for extended wear.
- Contoured panels for a flattering shape.
- Body-sculpting full-coverage fabric for a smooth streamlined fit.
- Antibacterial and anti-odour technology

Recommended Activities Training, HIIT.
Colours Available BLK/SIL.
Size Range XXS, XS, XST, S, ST, M, MT, L, LT, XL, XXL.
Rise Mid Rise. **Waistband** 8CM comfort waistband.
Fit Moderate: 15-20 Mmhg*.
Fabric Interlock 62% Polyamide, 38% Elastane.



WA4178b

**FITNESS
COMPRESSION
7/8 TIGHTS**

GARMENT FEATURES

- Mild compression support with comfortable fit for all-day wear.
- Comfortable 8CM wide waistband for extended wear.
- Contoured panels for a flattering shape.
- Body-sculpting full-coverage fabric for a smooth streamlined fit.
- Antibacterial and anti-odour technology

Recommended Activities Training, HIIT.
Colours Available BLK/SIL.
Size Range XXS, XS, XST, S, ST, M, MT, L, LT, XL, XXL.
Rise Mid Rise. **Waistband** 8CM comfort waistband.
Fit Moderate: 15-20 Mmhg*.
Fabric Interlock 62% Polyamide, 38% Elastane.



WA5386b

**FITNESS
COMPRESSION
3/4 TIGHTS**

GARMENT FEATURES

- Mild compression support with comfortable fit for all-day wear.
- Comfortable 8CM wide waistband for extended wear.
- Contoured panels for a flattering shape.
- Body-sculpting full-coverage fabric for a smooth streamlined fit.
- Antibacterial and anti-odour technology

Recommended Activities Training, HIIT.
Colours Available BLK/SIL.
Size Range XXS, XS, XST, S, ST, M, MT, L, LT, XL, XXL.
Rise Mid Rise. **Waistband** 8CM comfort waistband.
Fit Moderate: 15-20 Mmhg*.
Fabric Interlock 62% Polyamide, 38% Elastane.



WA4482b

**FITNESS
COMPRESSION
4" SHORTS**

GARMENT FEATURES

- Mild compression support with comfortable fit for all-day wear.
- Comfortable 8CM wide waistband for extended wear.
- Contoured panels for a flattering shape.
- Body-sculpting full-coverage fabric for a smooth streamlined fit.
- Antibacterial and anti-odour technology

Recommended Activities Training, HIIT.
Colours Available BLK/SIL.
Size Range XXS, XS, S, M, L, XL, XXL.
Rise Mid Rise. **Waistband** 8CM comfort waistband.
Fit Moderate: 15-20 Mmhg*.
Fabric Interlock 62% Polyamide, 38% Elastane.

X

X

X

ASPIRE COMPRESSION

From training to game day, the Aspire Compression range, supports key muscles and delivers freedom of movement so you can aim higher and train stronger than ever before.



MA5860b / WA5862b
**ASPIRE
COMPRESSION
TIGHTS**

GARMENT FEATURES

- Full length compression tight
- Moisture-wicking fabric
- Drawstring waistband
- Graduated compression for improved circulation
- Flatlock seams to reduce chafe

Recommended Activities Training, Team Sports, Running.
Colours Available BLK/SIL.
Size Range Men: XS, S, M, L, XL, XXL, XXXL. Women: XS, S, M, L, XL.
Rise Regular Waistband Men: 3.5cm covered elastic with drawstring. Women: 4cm comfort waistband. **Fit** MODERATE: 15-20 mmhg*
Fabric 75% Nylon, 25% Elastane.



WA5863b
**ASPIRE
COMPRESSION
3/4 TIGHTS**

GARMENT FEATURES

- Compression 3/4 tight
- Moisture-wicking fabric
- Drawstring waistband
- Flatlock seams to reduce chafe

Recommended Activities Training, Team Sports, Running.
Colours Available BLK/SIL.
Size Range XS, S, M, L, XL.
Rise Regular Waistband 4cm comfort waistband.
Fit MODERATE: 15-20 mmhg*
Fabric 75% Nylon, 25% Elastane.



MA5861b / WA5864b
**ASPIRE
COMPRESSION
SHORTS**

GARMENT FEATURES

- Compression short
- Moisture-wicking fabric
- Drawstring waistband
- Flatlock seams to reduce chafe

Recommended Activities Training, Team Sports, Running.
Colours Available BLK/SIL.
Size Range Men: XS, S, M, L, XL, XXL, XXXL. Women: XS, S, M, L, XL.
Rise Regular Waistband Men: 3.5cm covered elastic with drawstring. Women: 4cm comfort waistband. **Fit** MODERATE: 15-20 mmhg*
Fabric 75% Nylon, 25% Elastane.

X

X

X

UTILITY LONGLINE INSULATION JACKET

With a water-resistant shell, 3M featherless fill for sustainable warmth and waterproof storage, the Utility Longline Insulation Jacket protects you from the elements when you're in transit.

1/ STAY WARM

Lightweight 3M™ Thinsulate™ Featherless Insulation is fast to dry and mimics the performance of 600 fill-power natural down even when wet, whilst a thermo-reflective inner back panel retains body heat for added warmth.

2/ STAY DRY

Double-weave, downproof shell with environmentally responsible C6 DWR treatment withstands rain and showers.

3/ ESSENTIAL STORAGE

Fleece-lined front side pockets with zip closure for warmth, plus an internal pocket and waterproof zip pocket on the chest for valuables.

4/ NO SMELL

Antibacterial and anti-odour technology keeps you fresher for longer between washes, reducing your environmental footprint.

Product Code WR6284b

Recommended Activities Transit, Casual.

Colours Available BLK/BLK, WHT/BLK.

Size Range XXS, XS, S, M, L, XL.

Fabric Outer Shell: 100% Polyester. Lining: 100% Nylon.

Thermo Reflective Lining: 100% Polyester. Insulation: 100% Polyester.



TWO THINGS YOU



TRAINING / 51



MR6265a / WR6283b

UTILITY
INSULATION JACKET

1/ STAY WARM

Lightweight 3M™ Thinsulate™ Featherless Insulation is fast to dry and mimics the performance of 600 fill-power natural down even when wet, whilst a thermo-reflective inner back panel retains body heat for added warmth.

2/ STAY DRY

Double-weave, downproof shell with environmentally responsible C6 DWR treatment withstands rain and showers.

3/ ESSENTIAL STORAGE

Fleece-lined front side pockets with zip closure for warmth, plus an internal pocket and waterproof zip pocket on the chest for valuables.

4/ NO SMELL

Antibacterial and anti-odour technology on lining keeps you fresher for longer between washes, reducing your environmental footprint.

Recommended Activities Transit, Casual.

Colours Available Men: BLK/BLK, CRH/BLK. Women: BLK/BLK, WHT/BLK.

Size Range Men: XS, S, M, L, XL, XXL. Women: XXS, XS, S, M, L, XL.

Fabric Outer Shell: 100% Polyester. Lining: 100% Nylon.

Thermo Reflective Lining: 100% Polyester. Insulation: 100% Polyester.



X

X

VECTR COMPRESSION SOCKS

VECTR is the ultimate sports performance sock, built for every sport and every shoe. Anatomically designed to provide advanced plantar fascia and arch support, X.LOCK compression technology locks the foot in place to reduce blistering. VECTR socks promote natural toe splay during impact, while zoned mesh ventilation ensures breathability and comfort.

1/ X.LOCK TECHNOLOGY

Under-foot Compression promotes greater blood flow.

2/ ANTI-BLISTER

Anti-blister & anatomical left/right design for improved fit and reduced friction.

3/ ULTIMATE COMFORT

Seamless toe construction for ultimate comfort.

4/ STAY DRY

Mesh panels to increase air flow and reduce sweat.

5/ NO SMELL

Antibacterial and anti-odour technology keeps you fresher for longer between washes, reducing your environmental footprint.

Product Code MR6204a / WR6205a

Recommended Activities Wet Weather Running.

Colours Available

Men: BLK/GRF, MXB/SRF. Women: BEW/WHT, BLK/GRF.

Size Range S, M, L, XL.

Fabric Outer: 79% Nylon,

21% Elastane.

Internal: PU 2.5 Layer.



TWO TIMES YOU

VECTR / 53

X



UA5041e / UA5046e / UA5051e

**VECTR
ULTRALIGHT
COMPRESSION
SOCKS**

GARMENT FEATURES

- X.LOCK system for arch, ankle and plantar fascia support
- Anatomical, anti-blister design for a secure fit and reduced friction
- Ergonomic left/right foot for an improved fit
- 1.25mm ultralight cushioning for greater comfort inside tight-fitting sports shoes
- Anti-abrasion seamless toe construction for comfort
- Zoned mesh ventilation for increased breathability
- Antibacterial and anti-odour technology keeps you fresher for longer between washes, reducing your environmental footprint
- Available in three lengths; No-Show, 1/4 Crew and Crew

Recommended Activities Training, Ball Sports, Running.

Colours Available

UA5041e: BLK/TTM, TTM/BLK, WHT/GRY. UA5046e: BLK/TTM, WHT/GRY. UA5051e: BLK/TTM, WHT/GRY.

Size Range S, M, L, XL. **Fit** MODERATE: 15-20 mmhg* at base of foot.

Fabric 45% Olefin, 43% Nylon, 12% Lycra.

X



UA5042e / UA5047e / UA5052e / UA5155e

**VECTR
LIGHT CUSHION
COMPRESSION
SOCKS**

GARMENT FEATURES

- X.LOCK system for arch, ankle and plantar fascia support
- Anatomical, anti-blister design for a secure fit and reduced friction
- Ergonomic left/right foot for an improved fit
- 2.5mm light cushioning for added protection without the bulk
- Anti-abrasion seamless toe construction for comfort
- Zoned mesh ventilation for increased breathability
- Antibacterial and anti-odour technology keeps you fresher for longer between washes, reducing your environmental footprint
- Available in four lengths; No-Show, 1/4 Crew, Crew and Full-Length

Recommended Activities Training, Ball Sports, Athletics.

Colours Available UA5042e: BLK/TTM, MAG/LGY, VBB/GRY, WHT/BLK.

UA5047e: BLK/TTM, WHT/GRY. UA5052e: BLK/TTM, UAQ/TRB, ULT/TRB, WHT/GRY.

UA5155e: BLK/TTM, HPK/GRY, TTM/BLK, WHT/GRY.

Size Range S, M, L, XL. **Fit** MODERATE: 15-20 mmhg* at base of foot (20-30 mmhg* at ankle - full length only).

Fabric 88% Nylon, 12% Lycra.

TWO TIMES YOU

VECTR / 54



UA5043e / UA5048e / UA5053e / UA5156e

**VECTR
CUSHION
COMPRESSION
SOCKS**

GARMENT FEATURES

- X.LOCK system for arch, ankle and plantar fascia support
- Anatomical, anti-blister design for a secure fit and reduced friction
- Ergonomic left/right foot for an improved fit
- 3.25mm maximum cushioning to support forefoot impact, push-off and heel impact
- Anti-abrasion seamless toe construction for comfort
- Zoned mesh ventilation for increased breathability
- Antibacterial and anti-odour technology keeps you fresher for longer between washes, reducing your environmental footprint
- Available in four lengths; No-Show, 1/4 Crew, Crew and Full-Length

Recommended Activities Running, Ball Sports, Training.

Colours Available

UA5043e: BLK/TTM, BSL/GRY, DYP/GRY, WHT/GRY. UA5048e: BLK/TTM, WHT/GRY.

UA5053e: BLK/TTM, BLK/WHT, WHT/BLK, WHT/GRY, WHT/ULT. UA5156e: BLK/TTM, WHT/GRY.

Size Range S, M, L, XL. **Fit** MODERATE: 15-20 mmhg* at base of foot. (20-30 mmhg* at ankle - full length only).

Fabric 88% Nylon, 12% Lycra.



UA5044e / UA5049e / UA5054e / UA5157e

**VECTR
MERINO LIGHT CUSHION
COMPRESSION
SOCKS**

GARMENT FEATURES

- X.LOCK system for arch, ankle and plantar fascia support
- Anatomical, anti-blister design for a secure fit and reduced friction
- Ergonomic left/right foot for an improved fit
- 2.5mm light cushioning for added protection without the bulk
- Anti-abrasion seamless toe construction for comfort
- Zoned mesh ventilation for increased breathability
- Antibacterial and anti-odour technology keeps you fresher for longer between washes, reducing your environmental footprint
- Available in four lengths; No-Show, 1/4 Crew, Crew and Full-Length

Recommended Activities Ball Sports, Team Sports, Running, Winter Sports.

Colours Available BLK/TTM, GRY/GRY.

Full Length Size Range S, M1, M2, L1, L2, XL. **Size Range** S, M, L, XL.

Fit MODERATE: 15-20 mmhg* at base of foot. (20-30 mmhg* at ankle - full length only).

Fabric 21% Merino, 24% Acrylic, 44% Nylon, 11% Lycra.

X

X

TWO TIMES YOU

VECTR / 55



UA5393e

VECTR ALPINE COMPRESSION SOCKS

GARMENT FEATURES

- X.LOCK system for arch, ankle and plantar fascia support
- Powerful compression support to calves, shins and tendons
- Graduated compression from the foot to the calf for greater venous return
- Lightly padded front shin section for protection and comfort under boots
- Cushioned footbed for comfort and wool yarns for warmth
- Linked seamless toe cage for added comfort
- Antibacterial and anti-odour technology keeps you fresher for longer between washes, reducing your environmental footprint
- Available in Full-Length only

Recommended Activities Skiing, Snowboarding, Hiking.

Colours Available BLK/TTM, TTM/MOS.

Size Range S, M, L, XL.

Fit MODERATE: 15-20 mmhg* at base of foot. (20-30 mmhg* at ankle - full length only).

Fabric 21% Merino, 24% Acrylic, 44% Nylon, 11% Lycra.



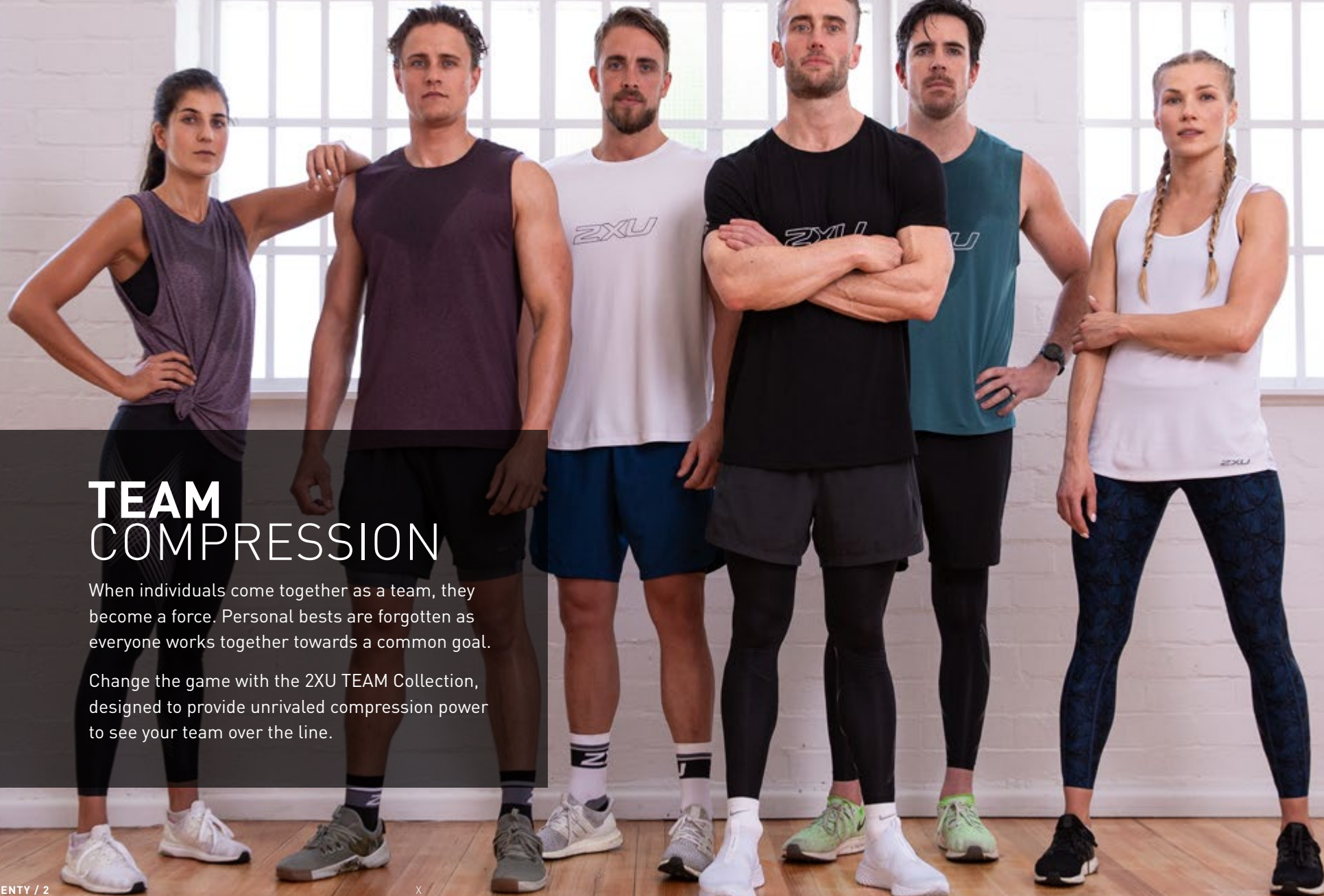

TEAM COMPRESSION

When individuals come together as a team, they become a force. Personal bests are forgotten as everyone works together towards a common goal.

Change the game with the 2XU TEAM Collection, designed to provide unrivaled compression power to see your team over the line.



MA3849b / WA4173b

COMPRESSION TIGHTS

1/ POWERFUL MUSCLE SUPPORT:

Lightweight yet powerful PWX fabric.

2/ GRADUATED COMPRESSION

Boosts blood flow to muscles, reducing muscle soreness and swelling (full-length tights only).

3/ MORE WEAR, LESS TEAR

Durable yarns that outlast the competition.

4/ TOTAL COMFORT:

Moisture-wicking yarns to keep the skin cool and dry.

5/ NO SMELL

Antibacterial and anti-odour technology keeps you fresher for longer between washes, reducing your environmental footprint.

Recommended Activities Training, HIIT.

Colours Available Men: BLK/NRO, BLK/SIL. Women: BLK/FLP, BLK/NRO, BLK/SIL.

Size Range Men: XXS-XXXL Women: XXS-XXL.

Rise Regular **Waistband** Men: 3.5CM Covered elastic with drawstring. Women: 4CM Covered elastic with drawstring.

Fit Firm: 20-25 Mmhg* **Fabric** Front: PWX 70D 72% Nylon, 28% Lycra.

Back: Mens: PWX 105D 65% Nylon, 35% Lycra. Womens: PWX 160D 72% Nylon, 28% Lycra.



WA4174b

COMPRESSION 7/8 TIGHTS

GARMENT FEATURES

- Compression support to the adductors, glutes, quadriceps, hamstrings and calves to reduce muscle vibration
- PWX 70D front panel for heightened flexibility and PWX 160D back panel for greater coverage
- Flatlock seams to reduce chafe
- Antibacterial and anti-odour

Recommended Activities Training, Ball Sports, Running.

Colours Available BLK/SIL.

Size Range XXS, XS, XST, S, ST, M, MT, L, LT, XL, XXL.

Rise Regular **Waistband** 4CM Covered elastic with drawstring.

Fabric Front: PWX 70D 72% Nylon, 28% Lycra.

Back: PWX 160D 72% Nylon, 28% Lycra.



MA3850b / WA4175b

COMPRESSION 3/4 TIGHTS

GARMENT FEATURES

- Compression support to the adductors, glutes, quadriceps and hamstrings to reduce muscle vibration
- PWX 70D front panel for heightened flexibility and PWX 105D [Mens] or PWX160D [Womens] back panel for greater coverage
- Flatlock seams to reduce chafe
- Antibacterial and anti-odour

Recommended Activities Training, Ball Sports, Running.

Colours Available BLK/SIL.

Size Range Men: XXS-XXXL Women: XXS-XXL.

Rise Regular **Waistband** Men: 3.5CM Covered elastic with drawstring.

Women: 4CM Covered elastic with drawstring. **Fabric** Front: PWX 70D

72% Nylon, 28% Lycra. Back: Mens: PWX 105D 65% Nylon, 35% Lycra. Womens: PWX 160D 72% Nylon, 28% Lycra.

X

X



MA3851b / WA4176b

COMPRESSION SHORTS

1/ POWERFUL MUSCLE SUPPORT

Lightweight yet powerful PWX fabric.

2/ MORE WEAR, LESS TEAR

Durable yarns that outlast the competition.

3/ TOTAL COMFORT

Moisture-wicking yarns to keep the skin cool and dry.

4/ NO SMELL

Antibacterial and anti-odour technology keeps you fresher for longer between washes, reducing your environmental footprint.

GARMENT FEATURES

- Compression support to the adductors, glutes, quadriceps and hamstrings to reduce muscle vibration
- PWX 70D front panel for heightened flexibility and PWX 105D (Mens) or PWX160D (Womens) back panel for greater coverage
- Flatlock seams to reduce chafe
- Antibacterial and anti-odour

Recommended Activities Training, Ball Sports, Running.

Colours Available Men: BGE/SIL, BLK/NRO, BLK/SIL. Women: BLK/NRO, BLK/SIL.

Size Range Men: XS, S, M, L, XL, XXL, XXXL. Women: XXS, XS, S, M, L, XL.

Rise Regular. **Waistband** Men: 3.5CM covered elastic with drawstring. Women: 4CM covered elastic with drawstring. **Fabric** Front: PWX 70D 72% Nylon, 28% Lycra. Back: Mens: PWX 105D 65% Nylon, 35% Lycra. Womens: PWX 160D 72% Nylon, 28% Lycra.

MA4508b

COMPRESSION 1/2 SHORTS

GARMENT FEATURES

- Compression support to the adductor and glute muscles
- PWX 70D front panel for heightened flexibility and PWX 105D back panel for greater coverage
- Low-profile for a discreet feel when worn as a base layer or under a uniform
- Drawstring waistband for a secure fit
- Flatlock seams to reduce chafe
- Antibacterial and anti-odour

Recommended Activities Training, Ball Sports, Running.

Colours Available Men: BGE/SIL, BLK/NRO, BLK/SIL.

Size Range XS, S, M, L, XL, XXL, XXXL.

Rise Regular. **Waistband** 3.5CM covered elastic with drawstring. **Fabric** Front: PWX 70D 72% Nylon, 28% Lycra. Back: PWX 105D 65% Nylon, 35% Lycra.

WA4481b

COMPRESSION 5" SHORTS

GARMENT FEATURES

- 4" compression short
- Compression support to the adductors, glutes, quadriceps and hamstrings to reduce muscle vibration
- PWX 70D front panel for heightened flexibility and PWX160D back panel for greater coverage
- Flatlock seams to reduce chafe
- Antibacterial and anti-odour

Recommended Activities Medium-Impact Training

Colours Available BLK/SIL.

Size Range XXS-XXL.

Rise Regular **Waistband** 4CM covered elastic with drawstring. **Fabric** Front: PWX 70D 72% Nylon, 28% Lycra. Back: PWX 160D 72% Nylon, 28% Lycra.

X

X



MA2308a / WA2270a

**COMPRESSION
LONG SLEEVE
TOP**

1/ POWERFUL MUSCLE SUPPORT:

Lightweight yet powerful PWX fabric.

2/ GRADUATED COMPRESSION

Boosts blood flow to muscles, reducing muscle soreness and swelling.

3/ MORE WEAR, LESS TEAR

Durable yarns that outlast the competition.

4/ TOTAL COMFORT

Moisture-wicking yarns to keep the skin cool and dry.

5/ NO SMELL

Antibacterial and anti-odour technology keeps you fresher for longer between washes, reducing your environmental footprint.

Recommended Activities

Low-Impact Training.

Colours Available Men: BLK/SIL. Women: BLK/BLK.

Size Range Men: XS-XXXL. Women: XS-XL.

Fit MODERATE: 12-16 mmhg*

Fabric PWX 70D 72% Nylon, 28% Lycra.



MA2307a / WA2269a

**COMPRESSION
SHORT SLEEVE
TOP**

GARMENT FEATURES

- PWX 70D fabric supports the biceps, triceps, deltoids and core stomach muscles and pulls the shoulders back for greater postural awareness
- Power Mesh panels deliver ventilation where you need it most
- Raglan sleeve construction for unrestricted movement
- Flatlock seams to reduce chafe
- Antibacterial and anti-odour

Recommended Activities

Low-Impact Training.

Colours Available Men: BLK/SIL. Women: BLK/BLK.

Size Range Men: XS-XXXL. Women: XS-XL.

Fabric PWX 70D 72% Nylon, 28% Lycra.

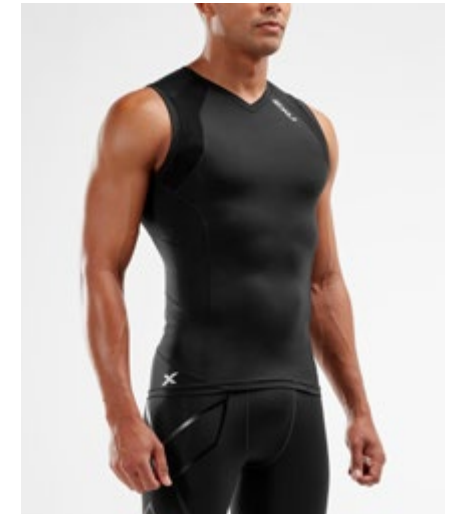

MA2306a

**COMPRESSION
SLEEVELESS
TOP**

GARMENT FEATURES

- PWX 70D fabric supports the biceps, triceps, deltoids and core stomach muscles and pulls the shoulders back for greater postural awareness
- Power Mesh panels deliver ventilation where you need it most
- Raglan sleeve construction for unrestricted movement
- Flatlock seams to reduce chafe
- Antibacterial and anti-odour

Recommended Activities

Low-Impact Training.

Colours Available BLK/BLK.

Size Range XS-XXXL.

Fabric PWX 70D 72% Nylon, 28% Lycra.

X

X



CA2546a

**YOUTH
COMPRESSION L/S TOP**

1/ POWERFUL MUSCLE SUPPORT:
Lightweight yet powerful PWX fabric.

2/ GRADUATED COMPRESSION
Boosts blood flow to muscles, reducing muscle soreness and swelling.

3/ MORE WEAR, LESS TEAR
Durable yarns that outlast the competition.

4/ TOTAL COMFORT
Moisture-wicking yarns to keep the skin cool and dry.

5/ NO SMELL
Antibacterial and anti-odour technology keeps you fresher for longer between washes, reducing your environmental footprint.

Recommended Activities Team Sports, Ball Sports, Athletics.
Colours Available BLK/BLK.
Size Range S, M, L, XL.
Fabric 80% Nylon, 20% Elastane (Invista Lycra®).

GARMENT FEATURES

- Compression support to the triceps, biceps, pectorals and deltoids
- Flatlock seams to reduce chafe
- Antibacterial and anti-odour

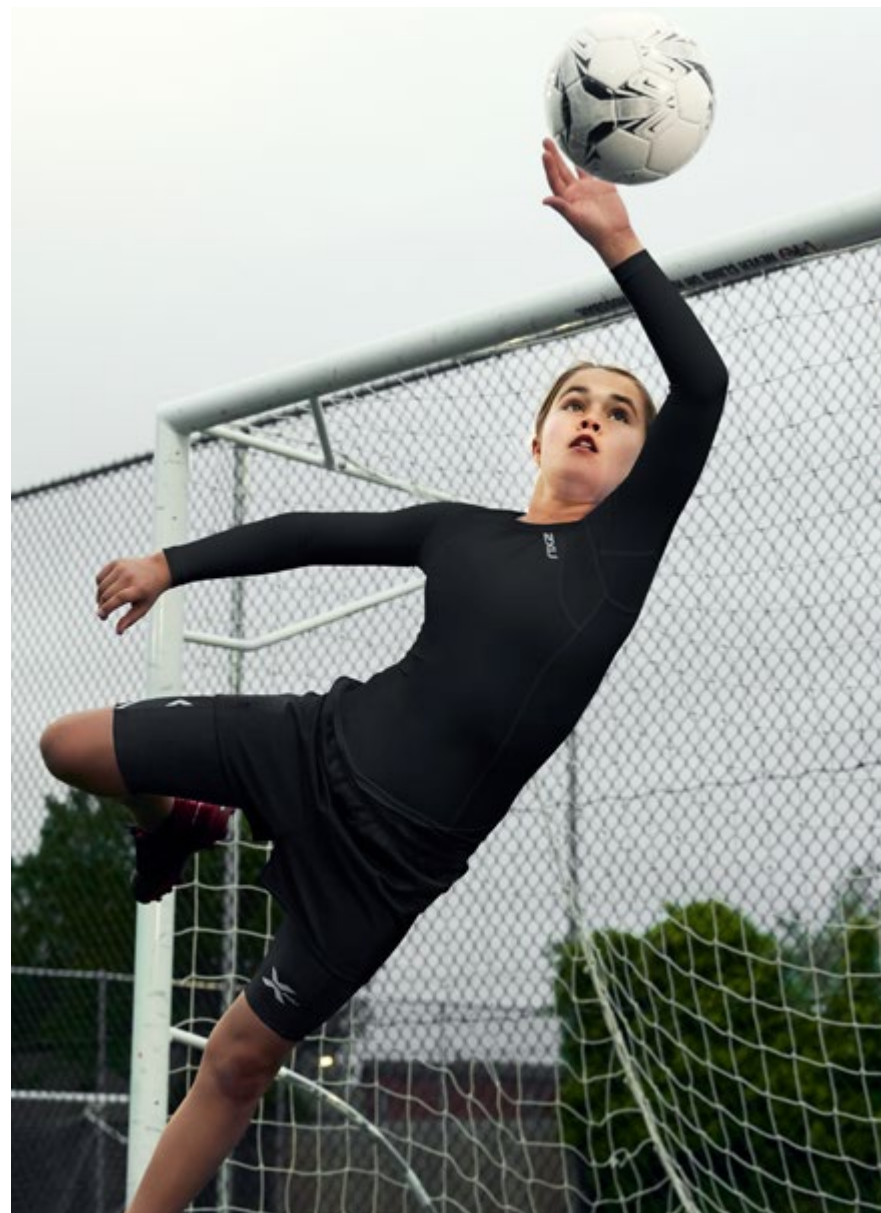



CA2549b (Boy's) / CA4158b (Girl's)

**YOUTH
COMPRESSION
TIGHTS**

1/ POWERFUL MUSCLE SUPPORT:
Lightweight yet powerful PWX fabric.

2/ GRADUATED COMPRESSION
Boosts blood flow to muscles, reducing muscle soreness and swelling.

3/ MORE WEAR, LESS TEAR
Durable yarns that outlast the competition.

4/ TOTAL COMFORT
Moisture-wicking yarns to keep the skin cool and dry.

5/ NO SMELL
Antibacterial and anti-odour technology keeps you fresher for longer between washes, reducing your environmental footprint.

Recommended Activities Team Sports, Ball Sports, Athletics.

Colours Available

Boys: BLK/BLK, BLK/NRO. Girls: BLK/BLU, BLK/HPK, BLK/NRO, BLK/SIL.

Size Range S, M, L, XL.

Rise Regular. **Waistband** 3CM covered elastic with drawstring.

Fabric 72% Nylon, 28% Lycra.



CA2548b

**YOUTH
COMPRESSION
SHORTS**

GARMENT FEATURES

- Compression support to the adductors, glutes, quadriceps and hamstrings
- Drawstring waistband for a secure fit
- Flatlock seams to reduce chafe
- Antibacterial and anti-odour

Recommended Activities Team Sports, Ball Sports, Athletics.

Colours Available

BGE/BGE, BLK/BLK, BLK/NRO.

Size Range S, M, L, XL.

Rise Regular. **Waistband** 3CM covered elastic with drawstring.

Fabric 72% Nylon, 28% Lycra.

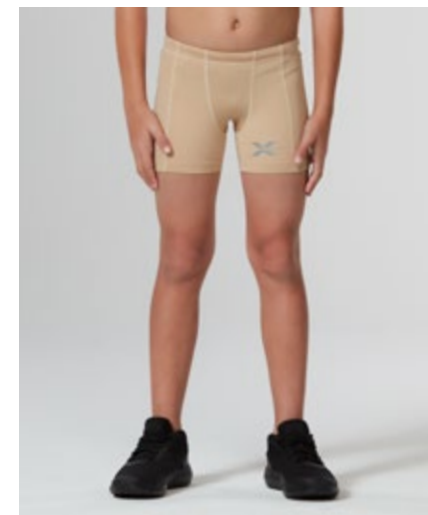

CA2547b (Boy's) / CA4804b (Girl's)

**YOUTH
COMPRESSION
1/2 SHORTS**

GARMENT FEATURES

- Compression support to the adductors, glutes, quadriceps and hamstrings
- Drawstring waistband for a secure fit
- Flatlock seams to reduce chafe
- Antibacterial and anti-odour

Recommended Activities Team Sports, Ball Sports, Athletics.

Colours Available

Boys: BLK/BLK, BGE/BGE, Girls: BLK/NRO, BLK/SIL, NVY/SIL.

Size Range S, M, L, XL.

Rise Regular. **Waistband** 3CM covered elastic with drawstring.

Fabric 72% Nylon, 28% Lycra.

X

X

X

RECOVERY COMPRESSION

Recovery is training. Even in your downtime, your choices can impact tomorrow's performance.

The 2XU RECOVERY collection is designed to accelerate your recovery so you can bounce back stronger.

POWER RECOVERY COMPRESSION TIGHTS

2XU's Power Recovery Compression Tights help you return to your peak in the fastest possible time. Featuring graduated stamping technology and powerful over-foot compression for improved blood flow and muscle repair, these tights are ideal after rigorous training or competition to reduce muscle soreness and swelling.

1/ GRADUATED STAMPING COMPRESSION

Increases blood flow for faster muscle repair and reduced swelling.

2/ OVER-FOOT COMPRESSION

For powerful, targeted relief to the entire lower body.

3/ TOTAL COMFORT

Comfort waistband and flat lock seams reduce chafe.

4/ STAY DRY

Moisture wicking yarns keep the skins surface cool and dry.

5/ NO SMELL

Anti-bacterial and anti-odour technology keeps you fresher for longer between washes, reducing your environmental footprint.

Product Code MA4417b / WA4418b

Recommended Activities

Recovery from: Strength Training, Ball Sports, Running.

Colours Available BLK/NRO.

Size Range

XXS, XS, S, ST, M, MT, L, LT, XL, XLT, XXL, XXLT, XXXL.

Rise Regular.

Waistband 5CM Brushed Inward Facing Elastic

Fit FIRM: 25-30 mmhg*.

Fabric PWX 105D: 65% Nylon, 35% Lycra.



TWO TIMES YOU



RECOVERY / 64



MA4419b / WA4420b

**REFRESH
RECOVERY
COMPRESSION
TIGHTS**

1/ GRADUATED COMPRESSION

Increases blood flow for faster muscle repair and reduced swelling.

2/ TOTAL COMFORT

Comfort waistband and flat lock seams reduce chafe.

3/ STAY DRY

Moisture wicking yarns keep the skin's surface cool and dry.

4/ NO SMELL

Anti-bacterial and anti-odour technology keeps you fresher for longer between washes, reducing your environmental footprint.

GARMENT FEATURES

- PWX 105D supports leg muscles to reduce muscle stiffness and swelling post-exercise
- Graduated fit to promote blood flow for faster muscle repair and recovery
- Comfort waistband for extended wear
- Moisture wicking to keep the skin's surface cool and dry
- Flatlock seams to reduce chafe
- Antibacterial and anti-odour technology

Recommended Activities Recovery from: Strength Training, Ball Sports, Running. **Colours Available** BLK/NRO.

Size Range XXS, XS, S, ST, M, MT, L, LT, XL, XLT, XXL, XXLT, XXXL.

Rise Regular. **Waistband** 5CM 2XU Jacquard Elastic.

Fit FIRM: 20-25 mmHg*.

Fabric PWX 105D: 65% Nylon, 35% Lycra.

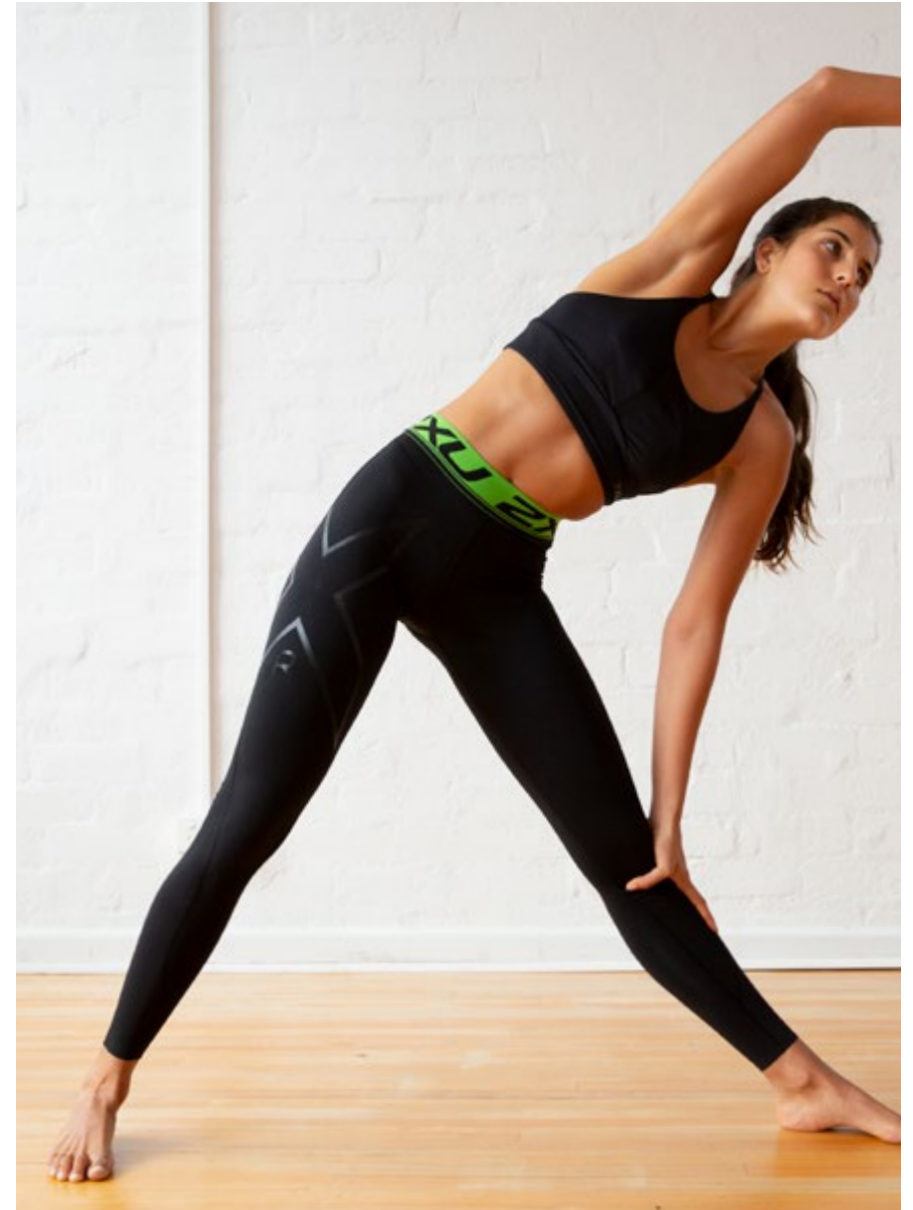

X

X

X



UA4427a

**RECOVERY
FLEX
ARM SLEEVES**

GARMENT FEATURES

- Lightweight yet powerful compression support to the forearms, elbows and biceps.
- Graduated fit to promote increased circulation for faster recovery.
- Flexible articulated elbow zone for greater comfort.
- Low-profile design that can be easily pulled on or off as required.

Recommended Activities Recovery from: Strength Training, Racquet Sports, Bat Sports, Rowing, Golf, Climbing, Motocross.
Colours Available BLK/NRO.
Size Range XXS, XS, S, M, L, XL.
Fit FIRM: 20-25 mmHg*.
Fabric 80% Nylon, 20% Lycra.



UA4425a

**RECOVERY
FLEX
LEG SLEEVES**

GARMENT FEATURES

- Lightweight yet powerful compression support to the quadriceps, hamstring and calf muscles.
- Graduated fit to promote increased circulation for faster recovery.
- Flexible articulated elbow zone for greater comfort.
- Low-profile design that can be easily pulled on or off as required.

Recommended Activities Recovery from: Any Lower Leg Activities.
Colours Available BLK/NRO.
Size Range XXS, XS, S, M, L, XL, XXL.
Fit FIRM: 25-35 mmHg*.
Fabric 80% Nylon, 20% Lycra.



UA5691a

**COMPRESSION
SOCKS FOR
RECOVERY**

GARMENT FEATURES

- Graduated fit to promote blood flow for faster muscle repair and recovery.
- Padded zones to the heels and balls of the feet for maximum comfort.
- Seamless linked toe cage for greater comfort.
- Vented toe panel for breathability.

Recommended Activities Recovery from: Strength Training, Ball Sports, Running.
Colours Available BLK/GRY.
Size Range S, M1, M2, L1, L2, XL.
Fit FIRM: 25-30 mmHg*.
Fabric 80% Micro Fibre Nylon, 20% Elastane.

X

X

x

TRAVEL COMPRESSION

x

Designed to keep you comfortable and supported in the air, the 2XU Travel range gives you the comfort and recovery edge. With graduated compression to reduce swelling and stiffness on long-haul flights, and soft breathable fabrics for comfort, you'll arrive fresh and ready to hit the ground running.



MA5642b / WA5643b

**FLIGHT
COMPRESSION
TIGHTS**

1/ GRADUATED COMPRESSION:

Maintains healthy blood flow, minimising swelling and stiffness on long-haul flights.

2/ ULTIMATE COMFORT

Soft, cotton-feel brushed fabric keeps you comfortable in the air.

3/ IMPROVED CIRCULATION

Boosted venous return and lymphatic drainage lowers the risk of DVT and swelling.

4/ NO SMELL

Antibacterial and anti-odour technology keeps you fresher for longer between washes, reducing your environmental footprint.

Recommended Activities Travel.

Colours Available BLK/BLK.

Size Range XXS, XS, S, ST, M, MT, L, LT, XL, XLT, XXL, XXLT, XXXL.

Rise Regular. **Waistband** 5CM 2XU Jacquard elastic.

Fit Moderate: 15-20 mmhg*. **Fabric** Tencel Blend: 47%Nylon, 34% Tencel, 19% Spandex. Crotch Panel: 94% Polyester, 6% Spandex.

GARMENT FEATURES

- 2XU jacquard waistband for ultimate comfort on a long-haul flight
- Light brush fabric on the inside for a soft feel against the skin
- Subtle branding
- Cotton blend for added comfort.
- Graduated compression to help reduce the risk of DVT and swelling
- 3D mesh crotch for better breathability and extra comfort (Men's only)
- Antibacterial and anti-odour



UA5689e

**FLIGHT
ULTRALIGHT
COMPRESSION
SOCKS**

GARMENT FEATURES

- Graduated compression increases circulation for less swelling
- Reduced long-haul fatigue and muscle stiffness
- Cotton blend and padded zones in the footbed for greater comfort
- Seamless linked toe cage
- Vented toe panel for greater breathability
- Anatomical left and right sock for improved fit

Recommended Activities Travel.

Colours Available BLK/BLK, TTM/TTM.

Size Range XS, S, M, L, XL.

Fit Moderate: 15-20 mmhg*.

Fabric Nylon 73%, Lycra 15%, Cotton 12%.



UA5688e

**FLIGHT
COMPRESSION
SOCKS**

GARMENT FEATURES

- Graduated compression increases circulation for less swelling
- Reduced long-haul fatigue and muscle stiffness
- Cotton blend and padded zones in the footbed for greater comfort
- Seamless linked toe cage
- Vented toe panel for greater breathability
- Anatomical left and right sock for improved fit

Recommended Activities Travel.

Colours Available BLK/BLK, TTM/TTM.

Size Range XS, S, M, L, XL.

Fit MODERATE: 15-20 mmhg*.

Fabric Nylon 67%, Lycra 15%, Cotton 18%.

X

X

X

MATERNITY ACTIVWEAR

Stay fit, active and supported throughout your pregnancy with the 2XU Maternity range. Graduated leg compression aids circulation to alleviate swollen legs and feet, while a breathable seam-free stomach panel is engineered for maximum comfort and support.





WA3595b

PRENATAL ACTIVE TIGHTS

1/ MAXIMUM SUPPORT

PWX and Power Mesh fabrics to support the lower back.

2/ REDUCE SWELLING

Graduated leg compression to boost circulation and reduce swelling in the ankles and feet.

3/ ULTIMATE COMFORT

Non-compression, breathable, seam-free stomach panel that grows with you during your pregnancy.

Recommended Activities

Pre-Natal Exercises as advised by a health care professional.

Colours Available BLK/NRO.

Size Range XS, S, M, L, XL.

Rise Under Bust. **Waistband** 4CM covered elastic. **Fit FIRM:** 20-25 mmhg*.

Fabric 72% Nylon, 28% Lycra.



WA3596b

PRENATAL ACTIVE 3/4 TIGHTS

GARMENT FEATURES

- Non-compression, breathable, seam-free stomach panel that grows with you during your pregnancy
- Powerful PWX 105D gusset for greater support
- Graduated leg compression to assist circulation and reduce swelling in the ankles and feet
- PWX and Power Mesh fabrics to support the lower back
- Flatlock seams to reduce chafe
- Recommended from 26 weeks+

Recommended Activities

Pre-Natal Exercises as advised by a health care professional.

Colours Available BLK/NRO.

Size Range XS, S, M, L, XL.

Rise Under Bust. **Waistband** 4CM covered elastic.

Fabric 72% Nylon, 28% Lycra.



WA3597b

PRENATAL ACTIVE SHORTS

GARMENT FEATURES

- Non-compression, breathable, seam-free stomach panel that grows with you during your pregnancy
- Powerful PWX 105D gusset for greater support
- PWX and Power Mesh fabrics to support the lower back
- Flatlock seams to reduce chafe
- Recommended from 26 weeks+

Recommended Activities

Pre-Natal Exercises as advised by a health care professional.

Colours Available BLK/NRO.

Size Range XS, S, M, L, XL.

Rise Under Bust. **Waistband** 4CM covered elastic.

Fabric 72% Nylon, 28% Lycra.

X

X

X



WA3598b

**POSTNATAL
ACTIVE
TIGHTS**

1/ MAXIMUM SUPPORT

PWX and Power Mesh fabrics to support the lower back.

2/ REDUCE SWELLING

Graduated leg compression to boost circulation and reduce swelling in the ankles and feet.

3/ IMPROVED RECOVERY

Comfortable yet supportive seam-free front compression panel works to assist abdominal muscle recovery.

Recommended Activities

Post-Natal Exercises as advised by a health care professional.

Colours Available BLK/NRO.

Size Range XS, S, M, L, XL.

Rise Under Bust. **Waistband** 4CM covered elastic. **Fit** FIRM: 20-25 mmhg*.

Fabric 72% Nylon, 28% Lycra.

GARMENT FEATURES

- Comfortable yet supportive seam-free, front compression panel works to assist abdominal muscle recovery
- Continuous PWX 105D abdomen-to-gusset panel to provide support while reducing chafe and avoiding cesarean scars
- Graduated leg compression to assist circulation and reduce swelling in the ankles and feet
- PWX and Power Mesh fabrics to support the lower back
- Flatlock seams to reduce chafe



WA3599b

**POSTNATAL
ACTIVE
3/4 TIGHTS**

GARMENT FEATURES

- Comfortable yet supportive seam-free, front compression panel works to assist abdominal muscle recovery
- Continuous PWX 105D abdomen-to-gusset panel provides support, while reducing chafe and avoiding cesarean scars
- PWX and Power Mesh fabrics support the lower back
- Flatlock seams to reduce chafe

Recommended Activities

Pre-Natal Exercises as advised by a health care professional.

Colours Available BLK/NRO.

Size Range XS, S, M, L, XL.

Rise Under Bust. **Waistband** 4CM covered elastic.

Fabric 72% Nylon, 28% Lycra.



WA3600b

**POSTNATAL
ACTIVE
SHORTS**

GARMENT FEATURES

- Comfortable yet supportive seam-free, front compression panel works to assist abdominal muscle recovery
- Continuous PWX 105D abdomen-to-gusset panel provides support while reducing chafe and avoiding cesarean scars
- PWX and Power Mesh fabrics support the lower back
- Flatlock seams to reduce chafe

Recommended Activities

Pre-Natal Exercises as advised by a health care professional.

Colours Available BLK/NRO.

Size Range XS, S, M, L, XL.

Rise Under Bust. **Waistband** 4CM covered elastic.

Fabric 72% Nylon, 28% Lycra.

X

X

X

x

ACCESSORIES

Add an edge to your workout with 2XU's range of accessories.

Designed with attention to every detail, and specifically curated to work with 2XU compression & apparel across multiple sports, maximize your training with 2XU accessories.

x

x



UQ6371f

**VENTED
RUN CAP**

GARMENT FEATURES

- Moisture wicking and fast-drying for comfort in all conditions.
- Breathable fabric to handle the toughest workouts.
- Durable fabric and construction to survive the elements.
- Reflective detail for visibility in low-light conditions.

Recommended Activities Running.
Colours Available BLK/GRF, MXA/BRF, BEW/WRF.
Size Range One-Size.
Fabric 100% Nylon.



UQ5685f

**RUN
CAP**

GARMENT FEATURES

- Moisture wicking and fast-drying for comfort in all conditions
- Breathable fabric with mesh panels for ventilation.
- Durable fabric and construction to survive the elements
- Reflective detail for visibility in low-light conditions
- Adjustable strap ensures the perfect fit

Recommended Activities Running.
Colours Available BLK/SIL, CHC/BLK, PLT/BLK, POS/WHT, TRB/WHT, WHT/SIL.
Size Range One-Size.
Fabric 100% Nylon.



UQ5686f

**RUN
VISOR**

GARMENT FEATURES

- Moisture wicking and fast-drying for comfort in all conditions
- Durable fabric and construction to survive the elements
- Reflective detail for visibility in low-light conditions
- Adjustable strap ensures the perfect fit

Recommended Activities Running.
Colours Available BLK/SIL, CHC/BLK, PLT/BLK, POS/WHT, TRB/WHT, WHT/SIL.
Size Range One-Size.
Fabric 100% Nylon.



UQ6165f

**PERFORMANCE
VISOR**

GARMENT FEATURES

- Moisture wicking and fast drying for comfort in all conditions
- Durable fabric and construction to survive the elements
- Reflective detail for visibility in low-light conditions
- Elastic headband for a secure fit

Recommended Activities Running.
Colours Available BLK/SIL, CHC/BLK, PLT/BLK, POS/WHT, TRB/WHT, WHT/SIL.
Size Range One-Size.
Fabric 100% Nylon.

X

X

X



X

X



UQ3577f
**RUN
BEANIE**

GARMENT FEATURES

- Breathable
- Moisture wicking
- Reflectivity for visibility in Low-light conditions

Recommended Activities Running.
Colours Available BLK/BLK.
Size Range One-Size.
Fabric 84% Polyester / 16% Elastane.



UQ5352f
**THERMAL
HEADBAND**

GARMENT FEATURES

- Heat-activating ceramic yarn
- Brushed inside for comfort
- Moisture-wicking
- Quick-drying
- Reflective logo for low-light visibility
- Contoured to cover cold ears

Recommended Activities Running.
Colours Available BLK/BLK.
Size Range One-Size
Fabric 100% Polyester.



UQ5692f
**SKINNY
HEADBAND
2-PACK**

GARMENT FEATURES

- Keep stray hairs under control during exercise.
- Silicone strip for a secure fit.
- Durable elastic with comfort stretch.

Recommended Activities Active Lifestyle.
Colours Available BLK/WHT.
Size Range One-Size.
Fabric 41.2% Polyamide, 26.8% Polyester, 10.3% Spandex, 21.7% Silicone.

TWO TIMES YOU

ACCESSORIES / 74

X



US1355f

SILICONE SWIM CAP

GARMENT FEATURES

- Engineered from premium grade silicone for up-most strength and durability
- Ergonomically designed for unparalleled comfort and security
- Ideal for latex intolerant athletes
- One size fits all
- Keeps head and hair dry

Recommended Activities Swimming, Triathlon.
Colours Available BLK/BLK, SIL/SIL, WHT/WHT.
Size Range One-Size.



UQ4023k

RIVAL GOGGLE MIRROR

GARMENT FEATURES

- Anatomical fit delivered through a low-profile design. Fly through the water with comfort and speed
- Adjustable straps for a secure, customised fit
- Anti-fog coating maintains clear vision with medium sunlight protection
- Mirrored lens for high glare protection

Recommended Activities Swimming, Triathlon.
Colours Available SIL/BLK.
Size Range One-Size.



UQ3977k

RIVAL GOGGLE SMOKE

GARMENT FEATURES

- Anatomical fit delivered through a low-profile design. Fly through the water with comfort and speed
- Adjustable straps for a secure, customised fit
- Anti-fog, smoke-coloured lens maintain clear vision with medium sunlight protection

Recommended Activities Swimming, Triathlon.
Colours Available BLK/CLR.
Size Range One-Size.

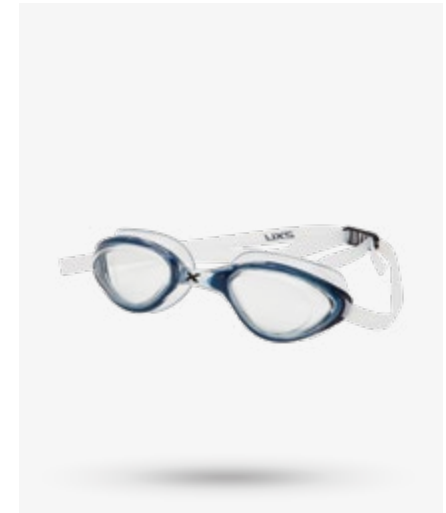

UQ3976k

RIVAL GOGGLE CLEAR

GARMENT FEATURES

- Anatomical fit delivered through a low-profile design. Fly through the water with comfort and speed
- Adjustable straps for a secure, customised fit
- Anti-fog coating maintains clear vision with medium sunlight protection

Recommended Activities Swimming, Triathlon.
Colours Available CLR/BLU.
Size Range One-Size.

X

X

X



UQ3805g
TRANSITION BAG

GARMENT FEATURES

- Two side water bottle holders
- Durable shell for bottom compartment
- Waterproof zipped bottom pouch for wet items
- Reflectivity for increased visibility and safety in low light conditions
- Mesh ventilated pocket on outside for shoes, and clip to attach helmet
- Multiple zipped pockets for storage

Recommended Activities Triathlon.
Colours Available BLK/BLK.
Size Range One-Size.
Capacity 22L. Main Pocket: 19L. Front Pocket: 3L.



UQ3803g
DISTANCE BACKPACK

GARMENT FEATURES

- Comfortably holds all your training, competition and everyday essentials
- Padded straps and a contoured back panel deliver total comfort
- Durable construction to withstand the elements
- Padded back compartment for secure laptop storage
- Side water bottle holders for easy access when you're on the go

Recommended Activities Everyday Active Lifestyle.
Colours Available BLK/BLK.
Size Range One-Size.
Capacity 22L. Main Pocket: 19L. Front Pocket: 3L.



UQ3804g
GYM BAG 45L

GARMENT FEATURES

- Adjustable strap with shoulder padding for comfort
- Studs on bottom to protect against rough surfaces
- Multiple zipped pockets for storage
- Water bottle holder
- Inner shoe compartment for easy storage

Recommended Activities Everyday Active Lifestyle.
Colours Available BLK/BLK.
Size Range One Size
Capacity 30L.

X

X

X



UQ5462g

**RUN
ARM BAND**

GARMENT FEATURES

- Snap seal closure.
- Fits a range of smart phone sizes.
- Reflective logo for low-light visibility.
- Comfortable stretch fabric with hook and loop fastening.

Recommended Activities Running.
Colours Available BLK/BLK.
Size Range OSFM.
Fabric 82% Nylon, 18% Spandex.



UQ5340h

**RUN
GLOVE**

GARMENT FEATURES

- Lightweight
- Reflective logo for low-light visibility
- Stretch fabric for comfort

Recommended Activities Cold Weather Running.
Colours Available BLK/SIL.
Size Range One-Size.
Fabric 100% Polyester.

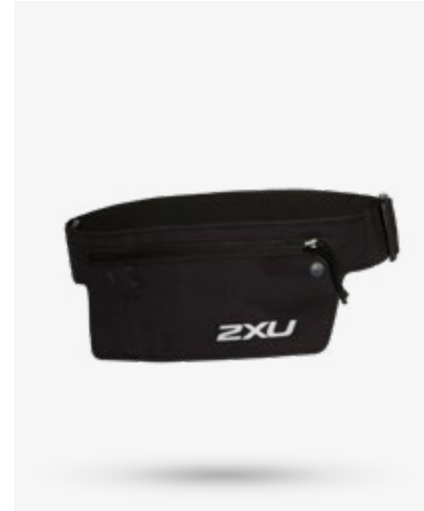

UQ5360g

**RUN
BELT**

GARMENT FEATURES

- Sits flat against the body to eliminate flapping
- Separate phone and key pockets
- Elastic waist for comfort
- Reflective logo for low-light visibility

Recommended Activities Running.
Colours Available BLK/BLK.
Size Range OSFM.
Fabric 100% Polyester.



UQ3800g

**NUTRITION
RACE BELT**

GARMENT FEATURES

- Safe and secure design, to help clearly display race details
- Low profile for a comfortable feel against the hips
- Loops to hold gels & nutrition supplements during endurance races
- Fully adjustable
- Quick-release toggle

Recommended Activities Active Lifestyle.
Colours Available BLK/BLK.
Size Range OSFM.
Fabric 85% Polyester, 15% Spandex.

X

X

X



UQ3799g
TIMING CHIP STRAP

GARMENT FEATURES

- Built with a combination of Nylon and Neoprene, so you can stay cool and comfortable from start to finish
- Adjustable hook and loop strap keeps your timing chip securely fastened
- Comfortable design with low chafing

Recommended Activities Triathlon.
Colours Available BLK/BLK.
Size Range One-Size.
Fabric 100% Nylon



UA1855g
PERFORMANCE LOCKED LACES

GARMENT FEATURES

- Race tested, lightweight, secure and reliable
- Ergonomic 'quick release/retain' lace locks for the fastest transitions
- Includes laces
- Suitable for all footwear
- Lightweight and low profile

Recommended Activities Triathlon, Running.
Colours Available BLK/BLK, WHT/WHT.
Size Range OSFM.
Fabric 30% Polyester, 70% Spandex.



UQ4812g
220Z WATERBOTTLE

GARMENT FEATURES

- Engineered to shield against any bad taste, mould or staining.
- Holds 22oz of liquid.

Recommended Activities Active Lifestyle.
Colours Available BLK/BLK, CLR/BLX.
Capacity 22oz.
Fabric 100% Polyester.

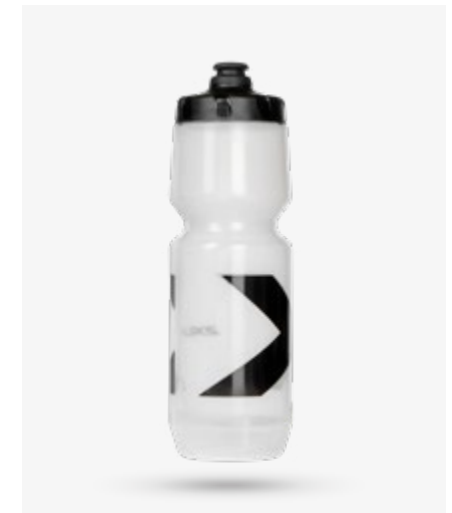

UQ4813g
260Z WATERBOTTLE

GARMENT FEATURES

- Engineered to shield against any bad taste, mould or staining.
- Holds 26oz of liquid.

Recommended Activities Active Lifestyle.
Colours Available BLK/BLK, CLR/BLX.
Capacity 26oz.
Fabric 100% Polyester.

X

X

X

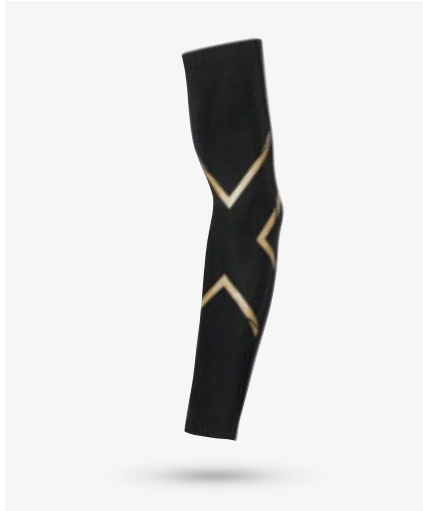

UA3513a
**MCS ELITE
COMPRESSION
ARM GUARDS**

GARMENT FEATURES

- MCS mapping provides targeted muscle support across the forearm to reduce muscle strain and soreness
- Graduated fit promotes an efficient warm-up pre-exercise and faster recovery post-exercise
- Lightweight yet powerful PWX fabric with multi-directional stretch
- Durable and moisture-wicking yarns to keep the skin cool and dry
- Flatlock comfort seams to reduce chafe
- Antibacterial and anti-odour

Recommended Activities

Basketball, Tennis, Rowing, Baseball, Gymnastics.
Colours Available BLK/GLD, BLK/NRO.
Size Range XS-XXL. **Fit** Moderate: 15-20 mmhg*.
Fabric PWX 70D 72% Nylon, 28% Elastane (Invista Lycra®).



UA3196a
**COMPRESSION
ARM GUARD
(SINGLE)**

GARMENT FEATURES

- Lightweight yet powerful compression support to protect and stabilise the forearm, elbow and biceps and reduce muscle fatigue
- Graduated fit promotes an efficient warm-up pre-exercise and faster recovery post-exercise
- Flatlock comfort seams to reduce chafe
- Antibacterial and anti-odour

Recommended Activities

Basketball, Tennis, Rowing, Baseball, Gymnastics.
Colours Available BLK/SIL, WHT/SIL.
Size Range XS-XXL. **Fit** MILD: 8-15 mmhg*.
Fabric 72% Nylon, 28% Elastane (Invista Lycra®).



UA4009a
**FLEX
COMPRESSION
ARM SLEEVES
(PAIR)**

GARMENT FEATURES

- Lightweight yet powerful compression support to protect and stabilise the forearm, elbow and biceps
- Flexible, articulated elbow for greater freedom of movement
- Graduated fit helps promote an efficient warm-up pre-exercise and faster recovery post-exercise
- Antibacterial and anti-odour

Recommended Activities

Basketball, Tennis, Rowing, Baseball, Gymnastics.
Colours Available WHT/GRY, BLK/GRY.
Size Range XS-XXL. **Fit** Moderate: 15-20 mmhg*.
Fabric 80% Nylon, 20% Elastane (Invista Lycra®).



UA3567a
**FLEX
COMPRESSION
ARM SLEEVES
(SINGLE)**

GARMENT FEATURES

- Lightweight yet powerful compression support to protect and stabilise the forearm, elbow and biceps
- Flexible, articulated elbow for greater freedom of movement
- Graduated fit helps promote an efficient warm-up pre-exercise and faster recovery post-exercise
- Antibacterial and anti-odour

Recommended Activities

Basketball, Tennis, Rowing, Baseball, Gymnastics.
Colours Available BLK/GRY, WHT/GRY.
Size Range XS-XXL. **Fit** Moderate: 15-20 mmhg*.
Fabric 80% Nylon, 20% Elastane (Invista Lycra®).

X

X

X



UA3064b

**MCS ELITE
COMPRESSION
CALF GUARDS**

GARMENT FEATURES

- MCS mapping provides targeted muscle support to the calves to reduce muscle strain and soreness
- Graduated fit promotes an efficient warm-up pre-exercise and faster recovery post-exercise
- Lightweight, low-profile design that can be worn on its own, under socks or under other apparel
- Flatlock comfort seams to reduce chafe
- Antibacterial and anti-odour

Recommended Activities

Running, Triathlon, Training, Ball Sports.
Colours Available BLK/GLD, BLK/NRO.
Size Range XXS, XS, S, M, L, XL, XXL.
Fit: FIRM: 20-25 mmhg*
Fabric PWX 70D: 72% Nylon, 28% Lycra.



UA1987b

**COMPRESSION
CALF GUARDS**

GARMENT FEATURES

- Lightweight yet powerful compression support to protect and stabilise the calf and shin muscles and reduce muscle fatigue
- Low-profile design that can be worn on its own, under socks or under other apparel
- Flatlock comfort seams to reduce chafe
- Antibacterial and anti-odour

Recommended Activities

Running, Triathlon, Training, Ball Sports.
Colours Available BLK/BLK, WHT/WHT.
Size Range XXS, XS, S, M, L, XL, XXL.
Fit: Moderate: 17-20 mmhg*
Fabric PWX 70D: 72% Nylon, 28% Lycra.



UA5458b

**X
COMPRESSION
CALF SLEEVES**

GARMENT FEATURES

- Compression support for the calves and shins
- Graduated fit promotes efficient warm-up pre-exercise and faster recovery post-exercise
- Zoned ventilation for breathability
- Seamless construction for greater comfort.
- Moisture wicking to keep the skin's surface cool and dry.

Recommended Activities

Running, Triathlon, Training, Ball Sports.
Colours Available BLK/BLK, MAG/LGY, TTM/BLK, VBB/GRY, WHT/WHT.
Size Range S, M, L, XL. **Fit:** FIRM: 20-25 mmhg*
Fabric 80% Nylon, 20% Lycra.

X

X

X



UA5690e

**24/7
COMPRESSION
SOCKS**

GARMENT FEATURES

- Graduated fit to promote increased blood flow and help prevent blood pooling
- Padded zones to the heels and balls of the feet for maximum cushioning
- Seamless linked toe cage for greater comfort
- Vented toe panel for greater breathability
- Suitable for all-day wear
- Antibacterial and anti-odour

Recommended Activities Travel & General Use.
Colours Available BLK/BLK.
Size Range OSFM. **Fit:** Firm: 20-25 mmhg*
Fabric 25% Nylon, 57% Cotton, 18% Lycra.



UQ6141e

**ANKLE SOCK
(3 PACK)**

GARMENT FEATURES

- High-filament nylon and elastane yarns provide durability and comfort
- Moisture wicking to keep the skin's surface cool and dry
- Achilles and heel cushioning with Ankle support
- Ball and toe cushioning with air flow panelling
- Seamless toe cage
- Antibacterial and anti-odour

Recommended Activities Running, Ball Sports, Training, HIIT, All-Day Wear.
Colours Available BLK/WHT, TRE/COL, WHT/BLK.
Size Range S/M, L/XL. **Fabric** 89% Nylon, 11% Lycra.



UQ6140e

**INVISIBLE SOCK
(3 PACK)**

GARMENT FEATURES

- High-filament nylon and elastane yarns provide durability and comfort
- Moisture wicking to keep the skin's surface cool and dry
- Fully seamless design for comfort
- No-sock look

Recommended Activities Running, Ball Sports, Training, HIIT, All-Day Wear.
Colours Available BLK/WHT, TRE/COL, WHT/BLK.
Size Range S/M, L/XL. **Fabric** 94% Nylon, 6% Lycra.

X

X

PRODUCT INFORMATION & GUIDES

x

x

SIZING & FITTING

X

X



TWO TIMES YOU

PRODUCT INFO / 83

X

X

QUAD SLEEVES

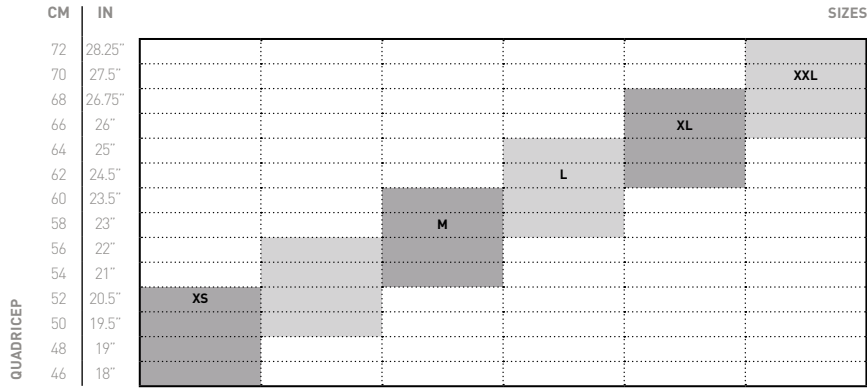

LEG SLEEVES

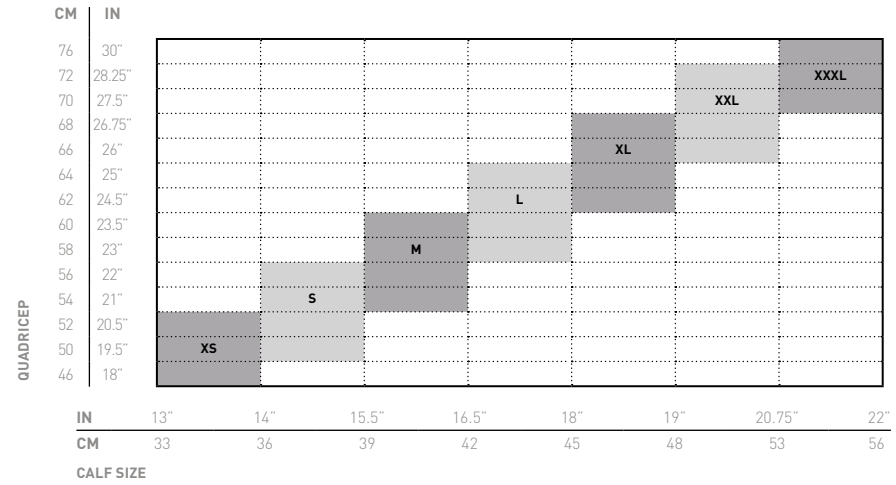

X

ARM GUARD / SLEEVES

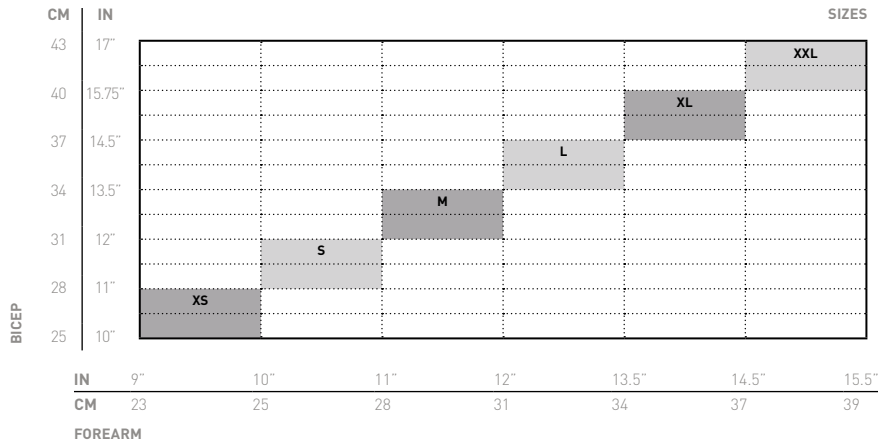

CALF GUARD / SLEEVES

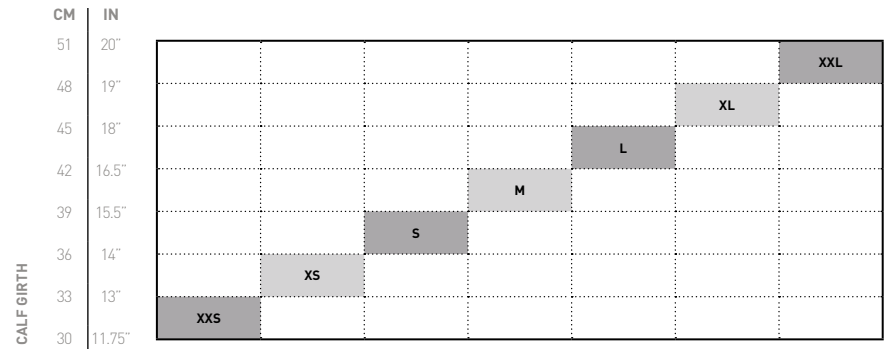

*Double extra large only available for calf guards

WOMEN'S COMPRESSION TIGHTS

HEIGHT	CM	SIZES																			
	FT/IN	XXS	XS	S	M	L	XL	XXL	XXL	XXL	XXL	XXL	XXL	XXL	XXL	XXL	XXL	XXL	XXL	XXL	
145	4'9"	XXS																			
150	4'11"		XS	S	M	L	XL														
155	5'1"								XXL												
160	5'3"																				
165	5'5"																				
170	5'7"		XST																		
175	5'9"				ST																
180	5'11"					MT		LT													
185	6'1"																				
190	6'3"																				
195	6'5"																				
		LB	66	77	88	99	110	120	130	144	155	165	175	188	200	210	220	230	242		
		KG	30	35	40	45	50	55	60	65	70	75	80	85	90	95	100	105	110		
		WEIGHT																			

WOMEN'S COMPRESSION SHORTS

HEIGHT	CM	SIZES																			
	FT/IN	XXS	XS	S	M	L	XL	XXL	XXL	XXL	XXL	XXL	XXL	XXL	XXL	XXL	XXL	XXL	XXL	XXL	
145	4'9"	XXS																			
150	4'11"		XS	S	M	L	XL														
155	5'1"								XXL												
160	5'3"																				
165	5'5"																				
170	5'7"																				
175	5'9"																				
180	5'11"																				
185	6'1"																				
190	6'3"																				
195	6'5"																				
		LB	66	77	88	99	110	120	130	144	155	165	175	188	200	210	220	230	242		
		KG	30	35	40	45	50	55	60	65	70	75	80	85	90	95	100	105	110		
		WEIGHT																			

ACTIVE MATERNITY

HIP RANGE		XXS	XS	S	M	L	XL
	CM		86-90	91-95	96-100	101-105	106-110
IN		34-35	36-37	38-39	40-41	42-43	44-45

WOMEN'S COMPRESSION TOPS

CHEST		XS	S	M	L	XL									
	CM		74	76	79	81	84	86	89	91	94	96	99	102	104
IN		29	30	31	32	33	34	35	36	37	38	39	40	41	42

WOMEN'S COMPRESSION SOCKS

CALF SIZE	CM	SIZES														
	IN	XXS	XS	S	M	L	XL	XXL	XXL	XXL	XXL	XXL	XXL	XXL	XXL	XXL
48	19"															XL
47	18.5"						L									
46	18"															
44	17.25"															
43	17"															
42	16.5"						M									
38	15"															
37	14.5"			S												
36	14"															
34	13"		XS													
32	12.5"															
30	11.75"															
		US SHOE SIZE	5-6.5	7	7.5	8	8.5	9	9.5	10	10.5	11.5-14				
		EU SHOE SIZE	35-37	37.5	38	39	39.5	40	41	41.5	43	43.5-47				

X

QUAD SLEEVES

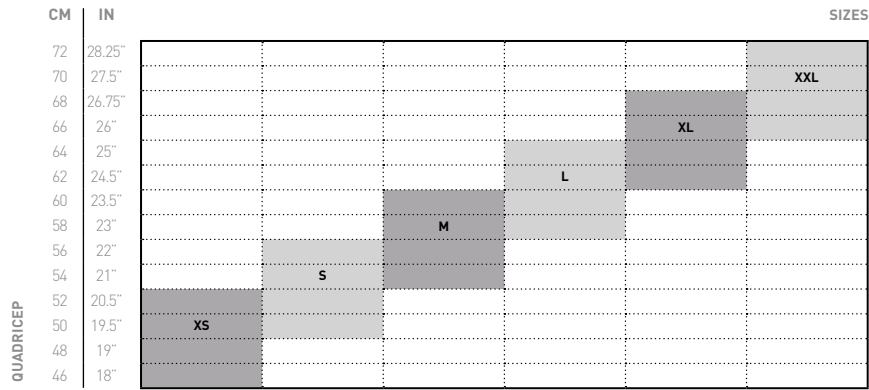

LEG SLEEVES

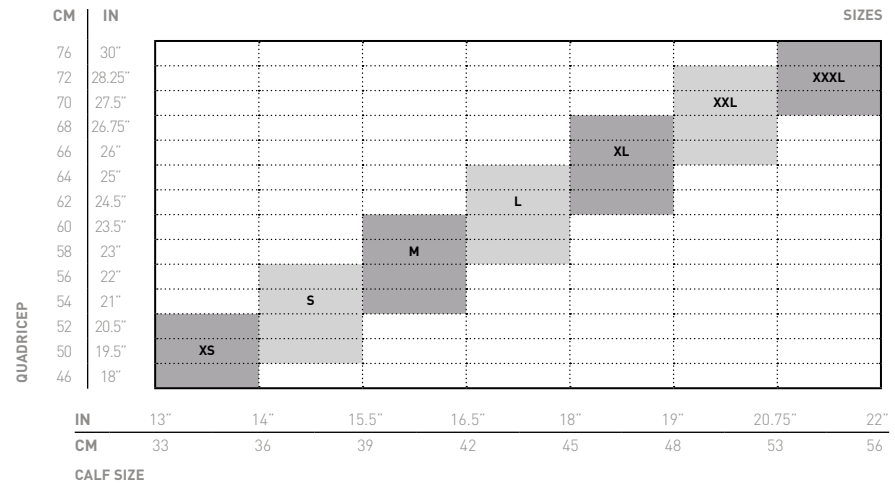

X

ARM GUARD / SLEEVES

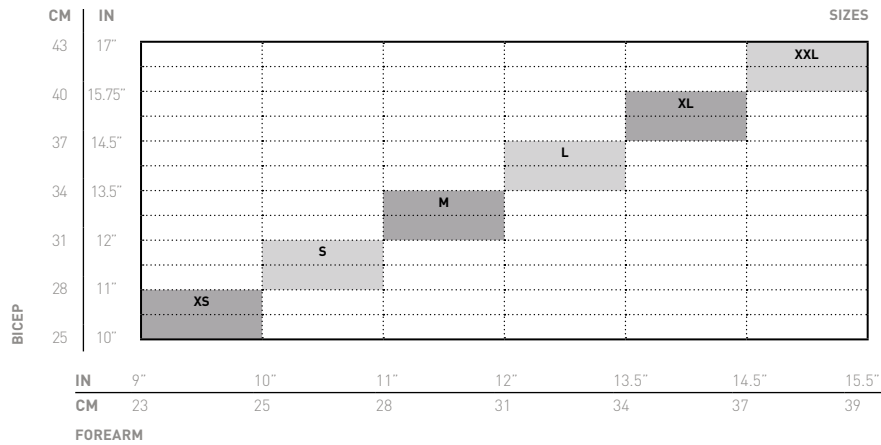

CALF GUARD / SLEEVES

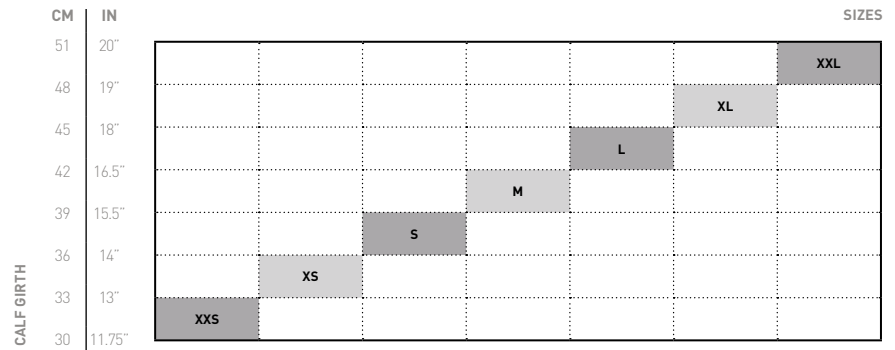

*Double extra large only available for calf guards

VECTR SOCKS - LOWER LENGTH

	SMALL	MEDIUM	LARGE	X-LARGE
EU	35 - 37.5	38 - 41.5	42 - 46	46.5 - 48.5
US-M	3.5 - 5.5	6 - 8	9 - 12	12.5 - 14
US-W	5 - 7	7.5 - 9.5	10 - 13	14 - 15.5

x

VECTR SOCKS - FULL LENGTH

SHOE SIZE

	SMALL	MEDIUM-1	MEDIUM-2	LARGE-1	LARGE-2	X-LARGE
EU	35 - 37.5	38 - 41.5	38 - 41.5	42 - 46	42 - 46	46.5 - 48.5
US-M	3.5 - 5.5	6 - 8	6 - 8	9 - 12	9 - 12	12.5 - 14
US-W	5 - 7	7.5 - 9.5	7.5 - 9.5	10 - 13	10 - 13	14 - 15.5

x

CALF SIZE

CM	30 - 37	32 - 37	38 - 43	36 - 40	41 - 46	43 - 50
INCH	11.75 - 14.5	12.5 - 14.5	15 - 17	14 - 15.75	16 - 18	17 - 19.75

FABRIC GLOSSARY

105D Power Mesh PWX Compression

The latest 105D Power Mesh PWX Compression technology offers incredible stabilisation for greater power output and reduced muscle movement to minimise fatigue. Powerful mesh construction delivers increased ventilation to keep the body cool, as well as aerodynamic, dimpled air flow technology for enhanced speed and moisture management.

39 Cell Neoprene

The most buoyant neoprene available, with a thickness ranging from 1mm to 5mm (5mm is the maximum permitted).

45 Cell Neoprene

Flexible material with a 1mm thickness, applied mainly to sleeves for ultimate flexibility, comfort and freedom of movement.

X-Lite

Super lightweight 96gsm fabric for a near-weightless performance. This lightweight fabric offers superior breathability and cooling for maximum performance gains. With a revolutionary knit structure this fabric offers unrivaled moisture management.

Hyper Stretch Double-Sided Nylon

For durability and flexibility.

Interlock Compression

Engineered with 40+40D nylon and latest elastomeric fibres, this 2XU fabric delivers strength, power, flexibility and durability with superior hand feel. Interlock is body sculpting and super flexible, with impressive muscle support and definition.

LD Chamois

Quick-drying long course triathlon chamois fused onto a high-density, hydrophobic foam base to manage moisture and deliver the comfort required to go the distance. Offers ample support for the bike while remaining discreet on the run.

Muscle Containment Stamping (MCS)

A revolutionary fabric support system traced over key muscle, tendon and fascia groups with targeted compression technology to wrap precise areas to further reduce muscle oscillation and damage. The advanced engineering provides greater compression power without excessive bulk.

Pro LD Chamois

Italian designed and made, this multi-layered chamois is exclusive to 2XU. Includes 80-density low-water absorption foam for added support in the aero position, and soft edging for less bulk on the run. Extremely comfortable and low profile, while still providing the cushioning required for long distance racing.

PWX Compression

2XU's proprietary PWX compression fabric has been developed for sport using medical technology. Developed at the yarn level, a compression fabric that is highly powerful but also lightweight and flexible. This is an oxymoron that no other brand has achieved.

2XU's proprietary knit fabrication uses highly durable high filament nylon yarns and the most powerful and long lasting elastane yarns to ensure our compression fabric retains consistent power, shape and comfort with repeat usage.

PWX 70D Our most flexible and breathable compression fabric. Light yet offering powerful compression and multi-directional stretch. Combining nylon and Invista Lycra yarns for greater durability. Moisture wicking, antibacterial and UPF 50+ sun protection.

PWX 105D Powerful yet still light, this fabric is engineered for sports. Offering powerful compression and multi-directional stretch. Combining nylon and Invista Lycra yarns for greater durability. Moisture wicking, antibacterial and UPF 50+ sun protection.

PWX 105D+ This latest PWX fabric offers powerful compression in a mid weight for greater coverage. Multi-directional stretch for consistent power. Combining nylon and INVISTA Lycra yarns for greater durability. Moisture wicking, antibacterial and UPF 50+ sun protection.

FABRIC GLOSSARY CONT.

Sensor Mesh X

Utilising high filament Nylon Lycra® blend, this durable water repellent fabric offers optimal air flow and moisture management.

SBR Power

Built from 70D elastane, SBR POWER offers unmatched power, durability and strength. Featuring high-denier Nylon yarn for impressive support and moisture management, plus mid-level gauge for muscle stabilisation.

SBR Skin

Powerful 70D elastane delivers muscle support and enhanced performance. Excellent stretch and recovery memory allows the garment to move with the body from start to finish.

SBR Vent

This Italian fabric delivers extreme cooling properties and exceptional aerodynamics. Low-denier construction, 3D mesh structure and cross-section yarns ensure this fabric keeps your body cool, dry and comfortable.

Speedline Chamois

Quick drying and low profile, this chamois is designed for moisture management and support in the saddle, while remaining incredibly lightweight and discreet on the run.

Swiss Vent

Industry-leading fabric engineered by the world's premier Swiss fabric mill. High-ventilation matrix knit, Coldblack heat-blocking technology, X-Cross polyester yarns and fine denier properties combine to create the world's leading heat-beating triathlon fabric. Tested and proven by the world's best.

Vapor

Featuring micro-filament polyester yarn with hydrophobic properties, this fabric offers supreme comfort and drape. A lower denier (finer) yarn on the outside wicks moisture from the higher denier (thicker) yarn on the inside to keep the wearer comfortable and dry. Zero cling to the body.

Yamamoto Limestone Neoprene

The world's most flexible swim neoprene, manufactured in Japan from ecological limestone rather than oil-based materials. A patented closed-cell neoprene rubber with an expansion ratio seven times greater than conventional wetsuit materials, delivering enhanced comfort and an unprecedented range of movement.

Yamamoto SCS Coated Neoprene

Unique patented material that features a specifically processed coating applied over a patented closed-cell neoprene rubber. This coating results in a micellar surface that repels water when in contact with air and exhibits hydrophilic properties when under water, ensuring ultra-low resistance in competitive conditions for enhanced comfort and reduced water resistance, with complete freedom of movement. Features an expansion ratio seven times greater than conventional wetsuit materials for easy wear in all conditions.

X

X

RESEARCH REFERENCES

x

1 Power balance: The smaller difference in weft and warp values is better for consistent compression power and flexibility in all directions. Less differentiation between weft and warp equals balanced power. We have adapted CK machines and stretched the application of these machines to create our fabrics - other brands have tried to copy but have been unsuccessful.

2 Compression power: The more force needed to stretch the fabric means the greater compression power the fabric exerts for muscle stabilisation and protection. This test stretches 50 x 100mm fabric samples along the weft direction of the knit. It is stretched to 170mm in length (IE: 170% of its original length), and the required force is measured by the Instron machine.

3,10 Brophy-Williams et al., (2016), International Journal of Sports Physiology & Performance – Effect of compression socks worn between repeated maximal running bouts

4 Broatch et al., (2018) – “The effects of 2XU compression

tights on quadriceps and calf muscle oscillatory patterns during treadmill running” – Manuscript in preparation

5, 9 Driller & Halson, (2013), International Journal of Sports Physiology & Performance – “The effects of wearing lower body compression garments during a cycling performance test”

6, 7, 11 Broatch et al., (2017), International Journal of Sports Physiology & Performance – “Lower-limb sports compression garments improve exercise performance and muscle blood flow during repeated-sprint cycling”

8 Zaleski et al., (2015), The Physician and Sports medicine – “The effect of compression socks worn during a marathon on hemostatic balance”

12 Dermont et al., (2015), Journal of Sports Medicine – “Changes in tissue oxygen saturation in response to different calf compression sleeves”

13, 14, 17 Driller & Halson, (2013), Journal of Science & Cycling – “The effects of lower-body compression garments on recovery between exercise bouts in highly-trained cyclists”

15 Hill et al., (2014), The Journal of Strength & Conditioning Research – “Influence of compression garments on recovery after marathon running”

16 Upton et al., (2017), The Journal of Strength & Conditioning Research – “Efficacy of compression garments on recovery from a simulated rugby protocol”

x

2XU

HUMAN PERFORMANCE. MULTIPLIED.

TEAM X CASUAL

CUSTOM COLLECTION



2XU
CUSTOM

TEAMX
CASUAL COLLECTION

BULK DYE AND SUBLIMATION MANUFACTURING



BULK-DYE

Our bulk-dye offering presents 3 colour options of black, navy and red. When selecting a bulk-dye garment 3 types of logo embellishment are available;



EMBROIDERY

Embroidery is the longest lasting embellishment method and provides a quality finish to garments. Whilst providing a nice finish on outer layers (e.g. jackets), embroidery is not ideal for larger back logos and chest logos applied on a thin/breathable fabric.



SCREEN PRINT

Screen printing is the most common method of textile printing, as it can be printed on almost all fabric types and provides long lasting prints with an accurate colour reproduction. Due to the set-up fees for each individual colour used, screen printing is recommended for medium to large volume orders.



HEAT TRANSFER

Heat transfer prints are pressed onto garments via high-temperature and heavy pressure. With less durability than screen print or embroidery, we strongly recommend cold machine wash only.



SUBLIMATION

Sublimation printing uses ink or dye to transfer your artwork into your desired garment. Sometimes referred to as "dye-sublimation printing," this process has many unique elements to it which allow you to have full creative freedom when customising your apparel. Traditionally this process is the most popular in the industry as it is so versatile allowing you to receive the exact colour and design you desire.

TEAM X FABRIC TECHNICAL INFORMATION

HI~FIL⁺

Utilising high filament technology, 2XU has engineered a performance fabric to maximise moisture management. Cross-channeled yarns wick vapour from the inner to outer layers in order to keep the wearer as dry and as comfortable as possible, while a mesh structure promises breathability. HI FIL+ includes Polygiene® odour control technology ensuring you stay fresh and odour free. Wear more, wash less and reduce your environmental footprint.

VAPOR

A lightweight, high-gauge woven fabric with four-way mechanical stretch. A solution that blocks out wind while remaining light and packable. High-filament yarns wick moisture away from the body to keep the wearer comfortable, dry and with zero cling to the body.

VAPOR^{XX}STRETCH

2XU's latest technology. Korean-made high gauge woven fabric with a powerful four-way stretch to move with you. High-filament polyester yarn wicks moisture and a dWR water repellent keeps you dry and comfortable. Beautiful hand feel and drape ensure style meets function.

ACTIVE LINER

For extreme moisture control through hot conditions, 2XU's ACTIVE LINING is built with polyester filament yarns to keep the wearer dry and chafe-free.

3D THERMAL SPHERE LOOP

Utilising 3D high filament polyester knit structure to maximise moisture management and trap heat to keep you warm. Polygiene® odour control technology ensuring you stay fresh and odour free.

DRIRELEASE

Permanent moisture-wicking properties that won't wash out. Dri-release® is eco-friendly and is embedded at the yarn level. This technology dries four times faster than cotton, is pilling resistant, wrinkle resistant, has no static cling and will retain its shape. FreshGuard® technology is also embedded in the yarn to eliminate odour.



Polygiene is the world's leading permanent Anti-Bacterial treatment. As the most respected and customer recognised permanent Anti-Bacterial treatment on the market, Polygiene prevents the growth of odour-causing bacteria and fungi at the source, permanently. Only active on the textile, it does not interfere with the skin's natural bacterial flora and does not wash out, as the technology is bound and permanently integrated into the fabric. Polygiene means no more washing after every wear.

MEN'S

TEAM X CUSTOM CASUAL COLLECTION



MEN'S TEAM X CUSTOM CASUAL COLLECTION

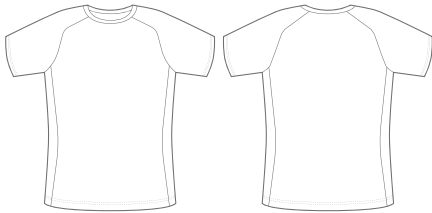

MX5716A

Men's Team X Comfort Tee

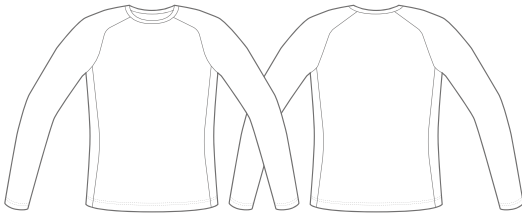

MX5730A

Men's Team X Longsleeve Comfort Top

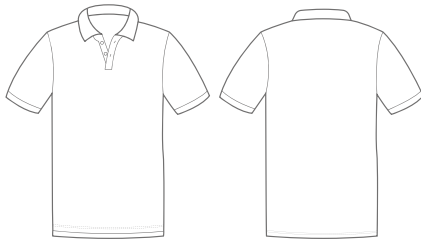

MX5728A

Men's Team X Polo

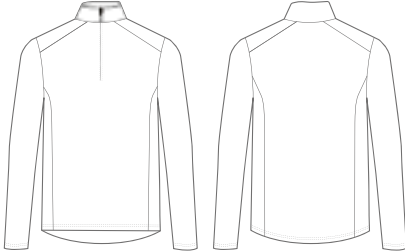

MX5732A

Men's Team X Longsleeve 1/4 Zip Top

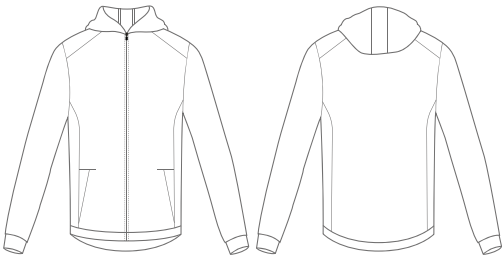

MX5734A

Men's Team X Zip Hoodie

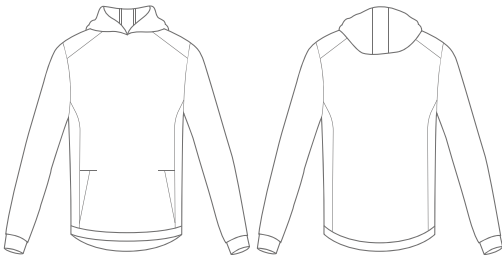

MX5930A

Men's Team X Pullover Hoodie

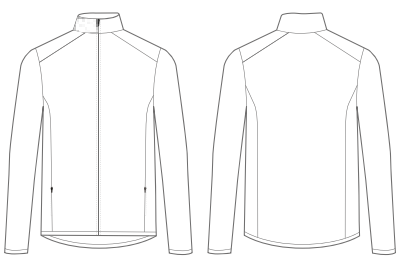

MX5736A

Men's Team X Track Jacket

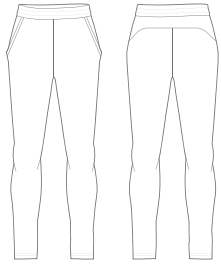

MX5738B

Men's Team X Track Pant

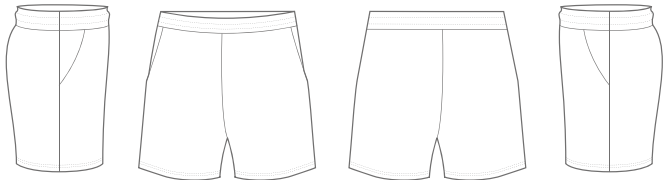

MX5748B

Men's Team X 5-Inch Casual Short

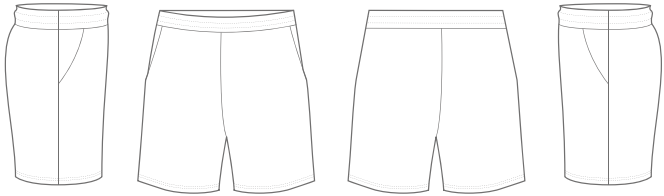

MX5746B

Men's Team X 7-Inch Casual Short

MEN'S TEAM X COMFORT TEE

MX5716A

SIZE RANGE: 2XS - 5XL

SUBLIMATION or BULK DYE (black, red and navy)



Levi is 188cm, 82kgs and wears a Medium

GARMENT FEATURES

01. Semi-fitted, casual style tee.
02. Crew neckline with neck band and interior taping for comfort and durability.
03. Short sleeve with raglan design.
04. Chafe-free flatlock seam construction.
05. Designed for all-round functionality.

FABRIC BENEFITS

DRI RELEASE

Permanent moisture-wicking properties that won't wash out. Dri-release® is eco-friendly and is embedded at the yarn level. This technology dries four times faster than cotton, is pilling resistant, wrinkle resistant, has no static cling and will retain its shape.

FreshGuard®

Technology embedded in the yarn to eliminate odour.

BULK DYE LOGO EMBELLISHMENT OPTIONS

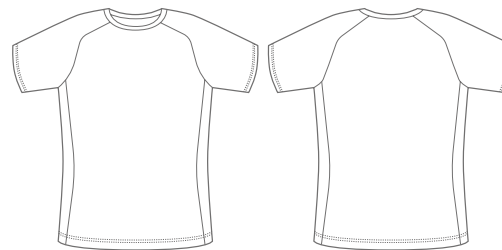

Garment pictured is sublimated, available bulk dye colours are black, navy and red.
Dri Release sublimation finishes with a marle look due to fabric composition.

MEN'S TEAM X LONGSLEEVE COMFORT TOP

MX5730A

SIZE RANGE: 2XS - 5XL

SUBLIMATION or BULK DYE (black, red and navy)



GARMENT FEATURES

01. Semi-fitted, casual style long sleeve top.
02. Crew neckline with neck band and interior taping for comfort and durability.
03. Long sleeve with raglan design.
04. Chafe-free flatlock seam construction.
05. Designed for all-round functionality.

FABRIC BENEFITS

DRI RELEASE

Permanent moisture-wicking properties that won't wash out. Dri-release® is eco-friendly and is embedded at the yarn level. This technology dries four times faster than cotton, is pilling resistant, wrinkle resistant, has no static cling and will retain its shape.

FreshGuard®

Technology embedded in the yarn to eliminate odour.

BULK DYE LOGO EMBELLISHMENT OPTIONS

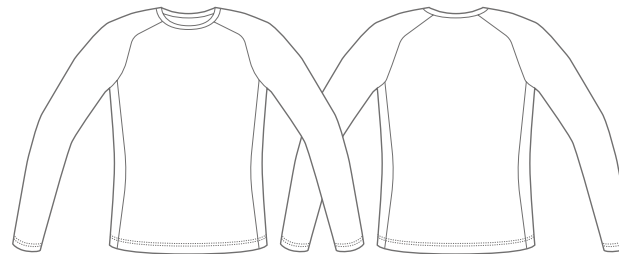

Levi is 188cm, 82kgs and wears a Medium

Garment pictured is sublimated, available bulk dye colours are black, navy and red. Dri Release sublimation finishes with a marle look due to fabric composition.

MEN'S TEAM X POLO

MX5728A

SIZE RANGE: 2XS - 5XL

SUBLIMATION or BULK DYE (black, red and navy)



GARMENT FEATURES

01. Semi-fitted, classic style polo.
02. Self fabric collar with two-button placket.
03. Short sleeves with self fabric armbands.
04. Side vents with tennis tail at hem for a full range of motion.
05. Chafe-free flatlock seam construction.
06. Designed for all-round functionality.

FABRIC BENEFITS

HI FIL

Utilising 2XU's breakthrough moisture management technology. Keeps you drier through high-filament yarns and cooler through our advanced knit structure.

Polygiene®

Odour control technology ensures you stay fresh and odour-free. Wear more, wash less and reduce your environmental footprint.

BULK DYE LOGO EMBELLISHMENT OPTIONS

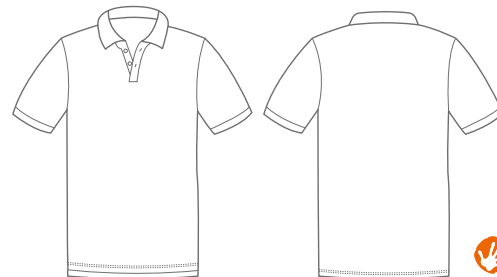

Levi is 188cm, 82kgs and wears a Medium

Garment pictured is sublimated, available bulk dye colours are black, navy and red.

MEN'S TEAM X LONGSLEEVE 1/4 ZIP TOP

MX5732A

SIZE RANGE: 2XS - 5XL

SUBLIMATION or BULK DYE (black, red and navy)



GARMENT FEATURES

01. Semi-fitted style.
02. Long sleeve, set-in sleeve design.
03. Stand-up collar for warmth and protection.
04. 1/4 zip at centre front.
05. Designed for all-round functionality.

FABRIC BENEFITS

3D THERMAL SPHERE LOOP

Utilising 3D high filament polyester knit structure to maximise moisture management and trap heat to keep you warm.

Polygiene®

Odour control technology ensuring you stay fresh and odour free. Wear more, wash less and reduce your environmental footprint.

BULK DYE LOGO EMBELLISHMENT OPTIONS

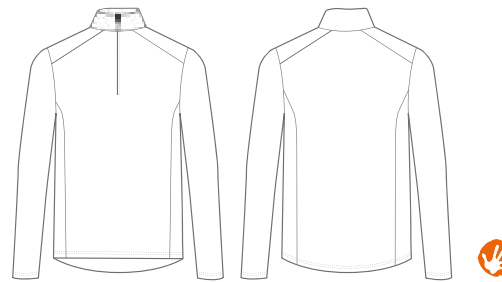

Levi is 188cm, 82kgs and wears a Medium

Garment pictured is sublimated, available bulk dye colours are black, navy and red.

MEN'S TEAM X ZIP HOODIE

MX5734A

SIZE RANGE: 2XS - 5XL

SUBLIMATION or BULK DYE (black, red and navy)



GARMENT FEATURES

01. Semi-fitted style.
02. Hood with adjustable bungee cord.
03. Full front zipper.
04. Sleeve and hem cuffs for optimal comfort and fit.
05. Side front pockets.
06. Designed for all-round functionality.

FABRIC BENEFITS

3D THERMAL SPHERE LOOP

Utilising 3D high filament polyester knit structure to maximise moisture management and trap heat to keep you warm.

Polygiene®

Odour control technology ensuring you stay fresh and odour free. Wear more, wash less and reduce your environmental footprint.

BULK DYE LOGO EMBELLISHMENT OPTIONS

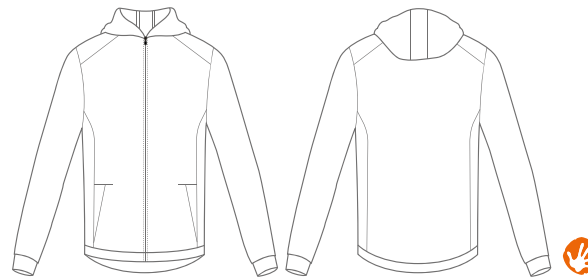

Levi is 188cm, 82kgs and wears a Medium

Garment pictured is sublimated, available bulk dye colours are black, navy and red.

MEN'S TEAM X PULLOVER HOODIE

MX5930A

SIZE RANGE: 2XS - 5XL

SUBLIMATION or BULK DYE (black, red and navy)



GARMENT FEATURES

01. Semi-fitted pullover style.
02. Hood with adjustable bungee cord.
03. Sleeve and hem cuffs for optimal comfort and fit.
04. Side front pockets.
05. Designed for all-round functionality.

FABRIC BENEFITS

3D THERMAL SPHERE LOOP

Utilising 3D high filament polyester knit structure to maximise moisture management and trap heat to keep you warm.

Polygiene®

Odour control technology ensuring you stay fresh and odour free. Wear more, wash less and reduce your environmental footprint.

BULK DYE LOGO EMBELLISHMENT OPTIONS

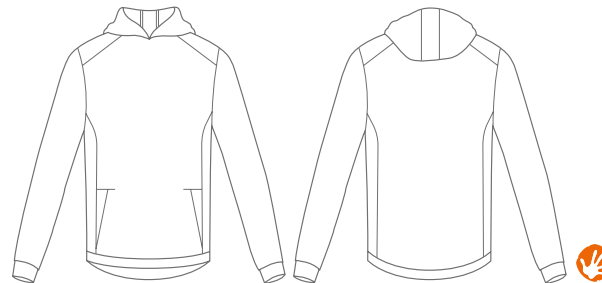

Levi is 188cm, 82kgs and wears a Medium

Garment pictured is sublimated, available bulk dye colours are black, navy and red.

MEN'S TEAM X TRACK JACKET

MX5736A

SIZE RANGE: 2XS - 5XL

SUBLIMATION or BULK DYE (black, red and navy)



GARMENT FEATURES

01. Semi-fitted style.
02. 4-way stretch for ease of movement and comfort.
03. Stand-up collar for warmth and protection.
04. Full front zipper.
05. Side front zip pockets for convenient storage.
06. Designed for all-round functionality.

FABRIC BENEFITS

VAPOR X STRETCH

2XU's latest technology. Korean-made high gauge woven fabric with a powerful four-way stretch to move with you. High-filament polyester yarn wicks moisture and a DWR water repellent keeps you dry and comfortable. Beautiful hand feel and drape ensure style meets function.

BULK DYE LOGO EMBELLISHMENT OPTIONS

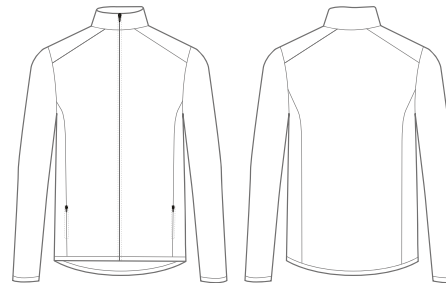

Levi is 188cm, 82kgs and wears a Medium

Garment pictured is sublimated, available bulk dye colours are black, navy and red.

MEN'S TEAM X TRACK PANT

MX5738B

SIZE RANGE: 2XS - 5XL

SUBLIMATION or BULK DYE (black, red and navy)



GARMENT FEATURES

01. Semi-fitted style with tapered leg.
02. 4-way stretch for ease of movement and comfort.
03. 4cm width elasticated waist band with a hidden drawcord for a personalised and secure fit.
04. Side front pockets for convenient storage.
05. Designed for all-round functionality.

FABRIC BENEFITS

VAPOR X STRETCH

2XU's latest technology. Korean-made high gauge woven fabric with a powerful four-way stretch to move with you. High-filament polyester yarn wicks moisture and a DWR water repellent keeps you dry and comfortable. Beautiful hand feel and drape ensure style meets function.

BULK DYE LOGO EMBELLISHMENT OPTIONS

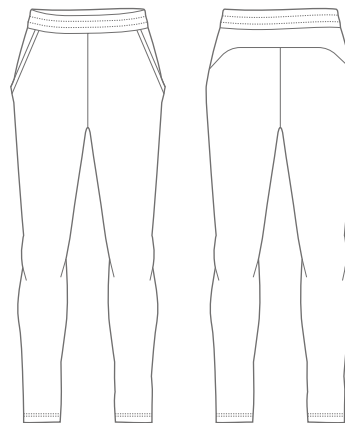

Levi is 188cm, 82kgs and wears a Medium

Garment pictured is sublimated, available bulk dye colours are black, navy and red.

MEN'S TEAM X 5-INCH CASUAL SHORT

MX5748B

SIZE RANGE: 2XS - 5XL

SUBLIMATION or BULK DYE (black, red and navy)



GARMENT FEATURES

01. 5-inch inseam length.
02. Straight hem design.
03. 4cm width elasticated waistband with an internal drawcord for a personalised and secure fit.
04. Side front pockets for convenient storage.
05. Designed for all-round functionality.

FABRIC BENEFITS

VAPOR

A lightweight, high-gauge woven fabric with a four-way mechanical stretch. A solution that blocks out wind while remaining light and packable. High-filament yarns wick moisture away from the body to keep the wearer comfortable, dry and with zero cling to the body.

BULK DYE LOGO EMBELLISHMENT OPTIONS

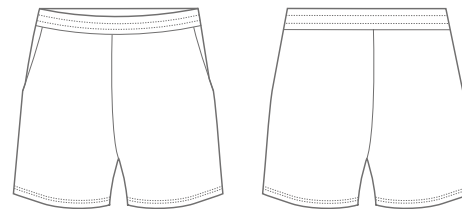

Garment pictured is sublimated, available bulk dye colours are black, navy and red.

Levi is 188cm, 82kgs and wears a Medium

MEN'S TEAM X 7-INCH CASUAL SHORT

MX5746B

SIZE RANGE: 2XS - 5XL

SUBLIMATION or BULK DYE (black, red and navy)



GARMENT FEATURES

01. 7-inch inseam length.
02. Straight hem design.
03. 4cm width elasticated waistband with an internal drawcord for a personalised and secure fit.
04. Side front pockets for convenient storage.
05. Designed for all-round functionality.

FABRIC BENEFITS

VAPOR

A lightweight, high-gauge woven fabric with a four-way mechanical stretch. A solution that blocks out wind while remaining light and packable. High-filament yarns wick moisture away from the body to keep the wearer comfortable, dry and with zero cling to the body.

BULK DYE LOGO EMBELLISHMENT OPTIONS

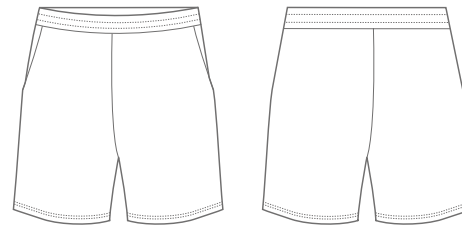

Levi is 188cm, 82kgs and wears a Medium

Garment pictured is sublimated, available bulk dye colours are black, navy and red.



TEAM X



AIS

SPORT
AUS

WOMEN'S

TEAM X CUSTOM CASUAL COLLECTION

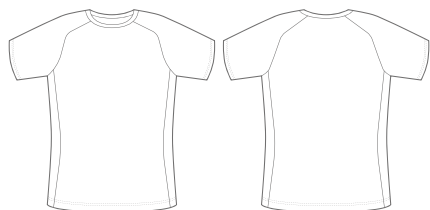
WOMEN'S TEAM X CUSTOM CASUAL COLLECTION



WX5717A

Women's Team X Comfort Tee

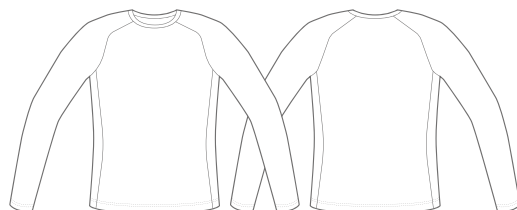

WX5731A

Women's Team X Longsleeve Comfort Top

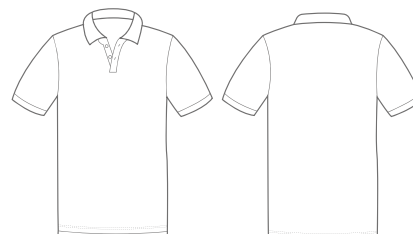

WX5729A 

Women's Team X Polo

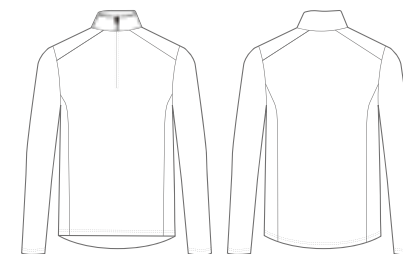

WX5733A 

Women's Team X Longsleeve 1/4 Zip Top



WX5735A 

Women's Team X Zip Hoodie

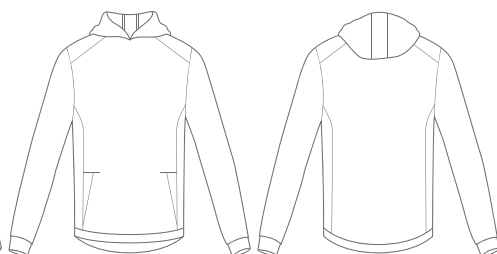

WX5931A 

Women's Team X Pullover Hoodie

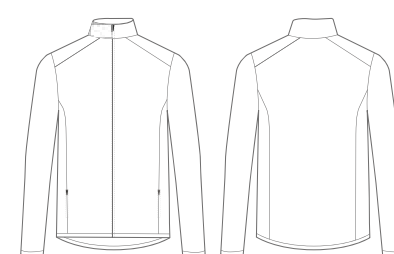

WX5737A

Women's Team X Track Jacket

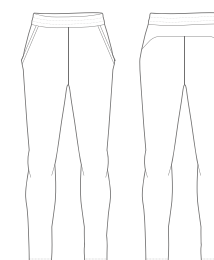

WX5739B

Women's Team X Track Pant

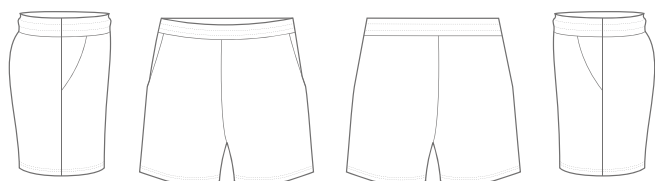

WX5749B

Women's Team X 5-Inch Casual Short

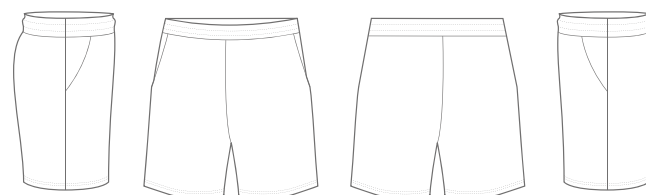

WX5747B

Women's Team X 7-Inch Casual Short

WOMEN'S TEAM X COMFORT TEE

WX5717A

SIZE RANGE: 2XS - 4XL

SUBLIMATION or BULK DYE (black, red and navy)

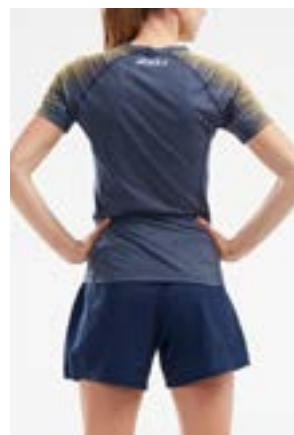

GARMENT FEATURES

01. Semi-fitted, casual style tee.
02. Crew neckline with neck band and interior taping for comfort and durability.
03. Short sleeve with raglan design.
04. Chafe-free flatlock seam construction.
05. Designed for all-round functionality.

FABRIC BENEFITS

DRI RELEASE

Permanent moisture-wicking properties that won't wash out. Dri-release® is eco-friendly and is embedded at the yarn level. This technology dries four times faster than cotton, is pilling resistant, wrinkle resistant, has no static cling and will retain its shape.

FreshGuard®

Technology embedded in the yarn to eliminate odour.

BULK DYE LOGO EMBELLISHMENT OPTIONS

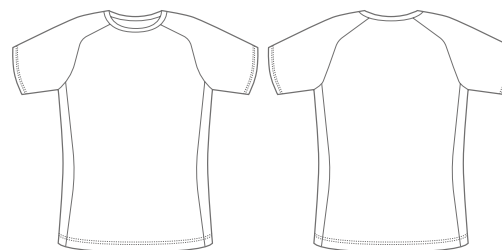

Emma is 180cm, 64kgs and wears a Small

Garment pictured is sublimated, available bulk dye colours are black, navy and red.
Dri Release sublimation finishes with a marle look due to fabric composition.

WOMEN'S TEAM X LONGSLEEVE COMFORT TOP

WX5731A

SIZE RANGE: 2XS - 4XL

SUBLIMATION or BULK DYE (black, red and navy)



GARMENT FEATURES

01. Semi-fitted, casual style long sleeve top.
02. Crew neckline with neck band and interior taping for comfort and durability.
03. Long sleeve with raglan design.
04. Chafe-free flatlock seam construction.
05. Designed for all-round functionality.

FABRIC BENEFITS

DRI RELEASE

Permanent moisture-wicking properties that won't wash out. Dri-release® is eco-friendly and is embedded at the yarn level. This technology dries four times faster than cotton, is pilling resistant, wrinkle resistant, has no static cling and will retain its shape.

FreshGuard®

Technology embedded in the yarn to eliminate odour.

BULK DYE LOGO EMBELLISHMENT OPTIONS

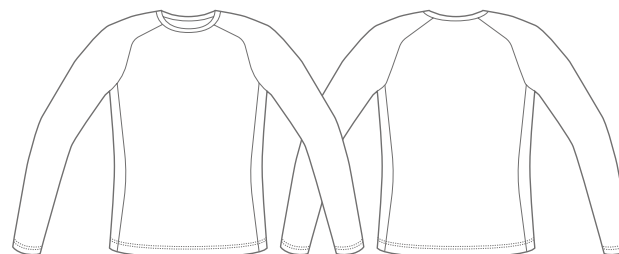

Emma is 180cm, 64kgs and wears a Small

Garment pictured is sublimated, available bulk dye colours are black, navy and red.
Dri Release sublimation finishes with a marle look due to fabric composition.

WOMEN'S TEAM X POLO

WX5729A

SIZE RANGE: 2XS - 4XL

SUBLIMATION or BULK DYE (black, red and navy)

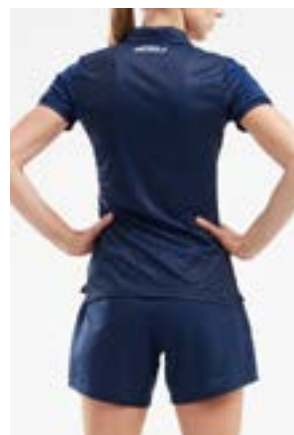

GARMENT FEATURES

01. Semi-fitted, classic style polo.
02. Self fabric collar with two-button placket.
03. Short sleeves with self fabric armbands.
04. Side vents with tennis tail at hem for a full range of motion.
05. Chafe-free flatlock seam construction.
06. Designed for all-round functionality.

FABRIC BENEFITS

HI FIL

Utilising 2XU's breakthrough moisture management technology. Keeps you drier through high-filament yarns and cooler through our advanced knit structure.

Polygiene®

Odour control technology ensures you stay fresh and odour-free. Wear more, wash less and reduce your environmental footprint.

BULK DYE LOGO EMBELLISHMENT OPTIONS

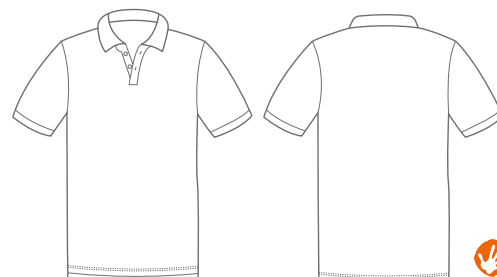

Emma is 180cm, 64kgs and wears a Small

Garment pictured is sublimated, available bulk dye colours are black, navy and red.

WOMEN'S TEAM X LONGSLEEVE 1/4 ZIP TOP

WX5733A

SIZE RANGE: 2XS - 4XL

SUBLIMATION or BULK DYE (black, red and navy)

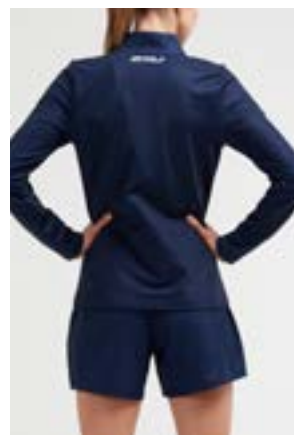

GARMENT FEATURES

01. Semi-fitted style.
02. Long sleeve, set-in sleeve design.
03. Stand-up collar for warmth and protection.
04. 1/4 zip at centre front.
05. Designed for all-round functionality.

FABRIC BENEFITS

3D THERMAL SPHERE LOOP

Utilising 3D high filament polyester knit structure to maximise moisture management and trap heat to keep you warm.

Polygiene®

Odour control technology ensuring you stay fresh and odour free. Wear more, wash less and reduce your environmental footprint.

BULK DYE LOGO EMBELLISHMENT OPTIONS

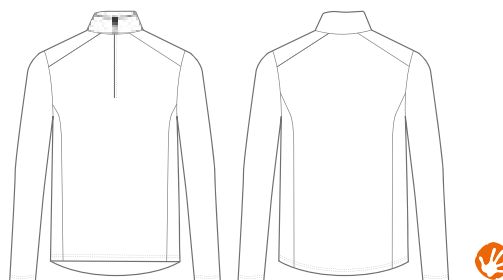

Emma is 180cm, 64kgs and wears a Small

Garment pictured is sublimated, available bulk dye colours are black, navy and red.

WOMEN'S TEAM X ZIP HOODIE

WX5735A

SIZE RANGE: 2XS - 4XL

SUBLIMATION or BULK DYE (black, red and navy)



GARMENT FEATURES

01. Semi-fitted style.
02. Hood with adjustable bungee cord.
03. Full front zipper.
04. Sleeve and hem cuffs for optimal comfort and fit.
05. Side front pockets.
06. Designed for all-round functionality.

FABRIC BENEFITS

3D THERMAL SPHERE LOOP

Utilising 3D high filament polyester knit structure to maximise moisture management and trap heat to keep you warm.

Polygiene®

Odour control technology ensuring you stay fresh and odour free. Wear more, wash less and reduce your environmental footprint.

BULK DYE LOGO EMBELLISHMENT OPTIONS

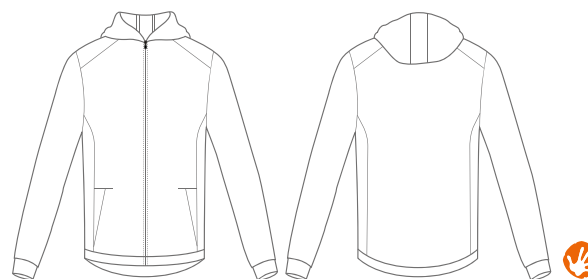

Emma is 180cm, 64kgs and wears a Small

Garment pictured is sublimated, available bulk dye colours are black, navy and red.

WOMEN'S TEAM X PULLOVER HOODIE

WX5931A

SIZE RANGE: 2XS - 4XL

SUBLIMATION or BULK DYE (black, red and navy)



GARMENT FEATURES

01. Semi-fitted pullover style.
02. Hood with adjustable bungee cord.
03. Sleeve and hem cuffs for optimal comfort and fit.
04. Side front pockets.
05. Designed for all-round functionality.

FABRIC BENEFITS

3D THERMAL SPHERE LOOP

Utilising 3D high filament polyester knit structure to maximise moisture management and trap heat to keep you warm.

Polygiene®

Odour control technology ensuring you stay fresh and odour free. Wear more, wash less and reduce your environmental footprint.

BULK DYE LOGO EMBELLISHMENT OPTIONS

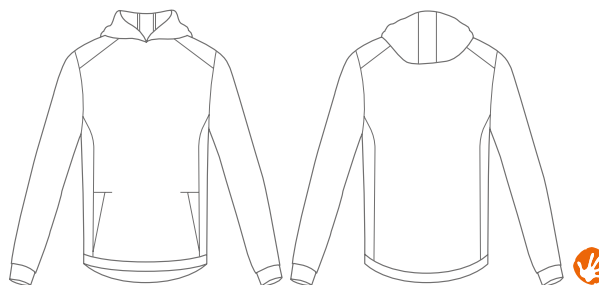

Emma is 180cm, 64kgs and wears a Small

Garment pictured is sublimated, available bulk dye colours are black, navy and red.

WOMEN'S TEAM X TRACK JACKET

WX5737A

SIZE RANGE: 2XS - 4XL

SUBLIMATION or BULK DYE (black, red and navy)



GARMENT FEATURES

01. Semi-fitted style.
02. 4-way stretch for ease of movement and comfort.
03. Stand-up collar for warmth and protection.
04. Full front zipper.
05. Side front zip pockets for convenient storage.
06. Designed for all-round functionality.

FABRIC BENEFITS

VAPOR X STRETCH

2XU's latest technology. Korean-made high gauge woven fabric with a powerful four-way stretch to move with you. High-filament polyester yarn wicks moisture and a DWR water repellent keeps you dry and comfortable. Beautiful hand feel and drape ensure style meets function.

BULK DYE LOGO EMBELLISHMENT OPTIONS

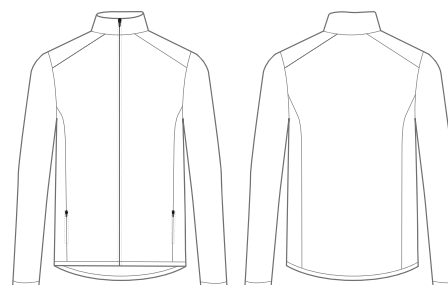

Emma is 180cm, 64kgs and wears a Small

Garment pictured is sublimated, available bulk dye colours are black, navy and red.

WOMEN'S TEAM X TRACK PANT

WX5739B

SIZE RANGE: 2XS - 4XL

SUBLIMATION or BULK DYE (black, red and navy)



GARMENT FEATURES

01. Semi-fitted style with tapered leg.
02. 4-way stretch for ease of movement and comfort.
03. 4cm width elasticated waist band with a hidden drawcord for a personalised and secure fit.
04. Side front pockets for convenient storage.
05. Designed for all-round functionality.

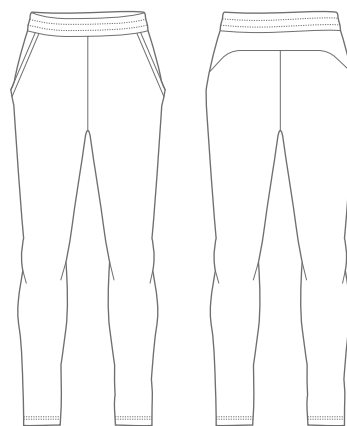

FABRIC BENEFITS

VAPOR X STRETCH

2XU's latest technology. Korean-made high gauge woven fabric with a powerful four-way stretch to move with you. High-filament polyester yarn wicks moisture and a dWR water repellent keeps you dry and comfortable. Beautiful hand feel and drape ensure style meets function.

BULK DYE LOGO EMBELLISHMENT OPTIONS



Emma is 180cm, 64kgs and wears a Small

Garment pictured is sublimated, available bulk dye colours are black, navy and red.

WOMEN'S TEAM X 5-INCH CASUAL SHORT

WX5749B

SIZE RANGE: 2XS - 4XL

SUBLIMATION or BULK DYE (black, red and navy)

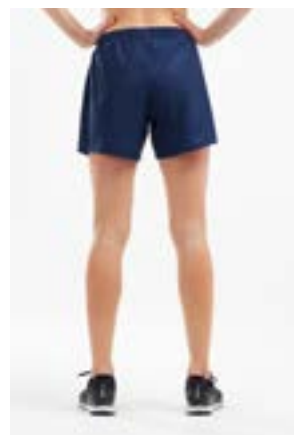

GARMENT FEATURES

01. 5-inch inseam length.
02. Straight hem design.
03. 4cm width elasticated waistband with an internal drawcord for a personalised and secure fit.
04. Side front pockets for convenient storage.
05. Designed for all-round functionality.

FABRIC BENEFITS

VAPOR

A lightweight, high-gauge woven fabric with a four-way mechanical stretch. A solution that blocks out wind while remaining light and packable. High-filament yarns wick moisture away from the body to keep the wearer comfortable, dry and with zero cling to the body.

BULK DYE LOGO EMBELLISHMENT OPTIONS

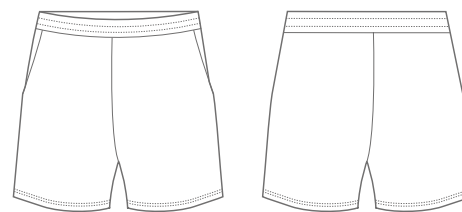

Emma is 180cm, 64kgs and wears a Small

Garment pictured is sublimated, available bulk dye colours are black, navy and red.

WOMEN'S TEAM X 7-INCH CASUAL SHORT

WX5747B

SIZE RANGE: 2XS - 4XL

SUBLIMATION or BULK DYE (black, red and navy)

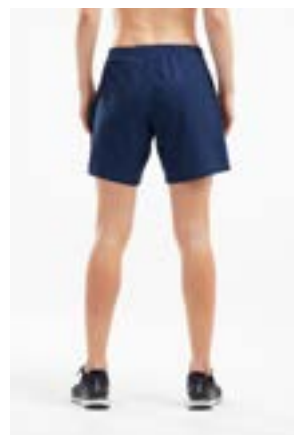

GARMENT FEATURES

01. 7-inch inseam length.
02. Straight hem design.
03. 4cm width elasticated waistband with an internal drawcord for a personalised and secure fit.
04. Side front pockets for convenient storage.
05. Designed for all-round functionality.

FABRIC BENEFITS

VAPOR

A lightweight, high-gauge woven fabric with a four-way mechanical stretch. A solution that blocks out wind while remaining light and packable. High-filament yarns wick moisture away from the body to keep the wearer comfortable, dry and with zero cling to the body.

BULK DYE LOGO EMBELLISHMENT OPTIONS

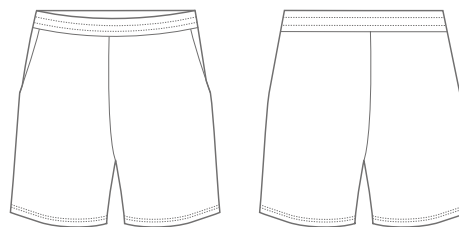

Emma is 180cm, 64kgs and wears a Small

Garment pictured is sublimated, available bulk dye colours are black, navy and red.



YOUTH

TEAM X CASUAL CASUAL COLLECTION

YOUTH TEAM X CUSTOM CASUAL COLLECTION

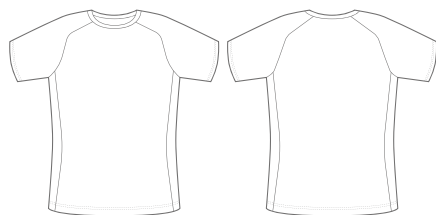

CX5723A
Youth Team X Comfort Tee

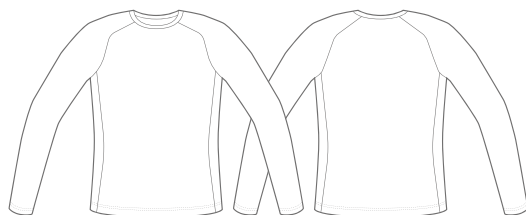

CX5759A
Youth Team X Longsleeve Comfort Top

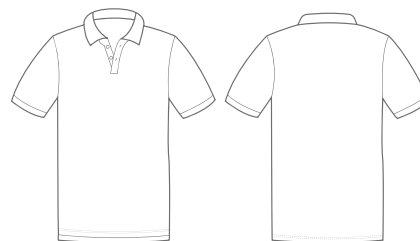

CX5758A 
Youth Team X Polo

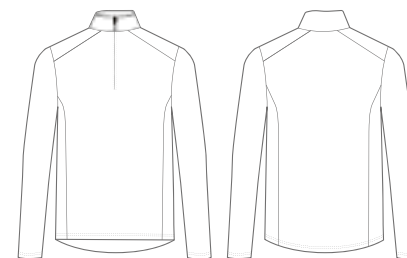

CX5760A 
Youth Team X Longsleeve 1/4 Zip Top

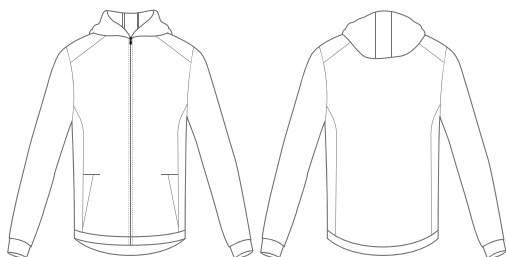

CX5761A 
Youth Team X Zip Hoodie

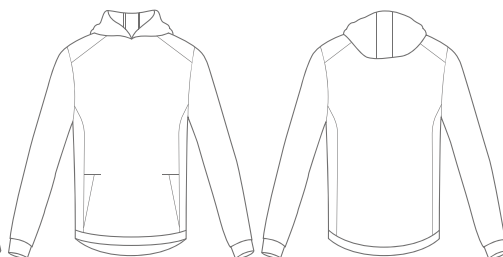

CX5932A 
Youth Team X Pullover Hoodie

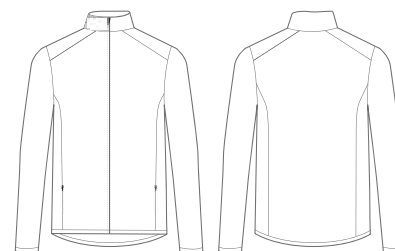

CX5762A
Youth Team X Track Jacket

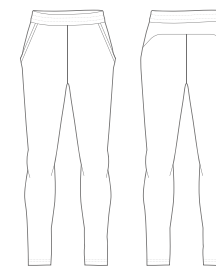

CX5763B
Youth Team X Track Pant

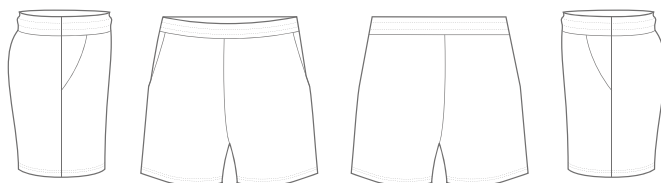

CX5764B
Youth Team X Casual Short

YOUTH TEAM X COMFORT TEE

CX5723A

UNISEX SIZE RANGE: 6,8,10,12,14

SUBLIMATION or BULK DYE (black, red and navy)

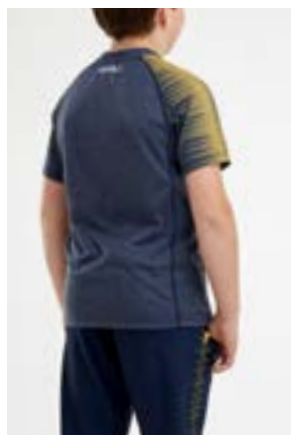

GARMENT FEATURES

01. Semi-fitted, casual style tee.
02. Crew neckline with neck band and interior taping for comfort and durability.
03. Short sleeve with raglan design.
04. Chafe-free flatlock seam construction.
05. Designed for all-round functionality.

FABRIC BENEFITS

DRI RELEASE

Permanent moisture-wicking properties that won't wash out. Dri-release® is eco-friendly and is embedded at the yarn level. This technology dries four times faster than cotton, is pilling resistant, wrinkle resistant, has no static cling and will retain its shape.

FreshGuard®

Technology embedded in the yarn to eliminate odour.

BULK DYE LOGO EMBELLISHMENT OPTIONS

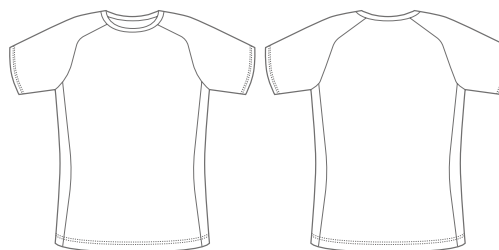

Garment pictured is sublimated, available bulk dye colours are black, navy and red.
Dri Release sublimation finishes with a marle look due to fabric composition.

YOUTH TEAM X LONGSLEEVE COMFORT TOP

CX5759A

UNISEX SIZE RANGE: 6,8,10,12,14

SUBLIMATION or BULK DYE (black, red and navy)



GARMENT FEATURES

01. Semi-fitted, casual style long sleeve top.
02. Crew neckline with neck band and interior taping for comfort and durability.
03. Long sleeve with raglan design.
04. Chafe-free flatlock seam construction.
05. Designed for all-round functionality.

FABRIC BENEFITS

DRI RELEASE

Permanent moisture-wicking properties that won't wash out. Dri-release® is eco-friendly and is embedded at the yarn level. This technology dries four times faster than cotton, is pilling resistant, wrinkle resistant, has no static cling and will retain its shape.

FreshGuard®

Technology embedded in the yarn to eliminate odour.

BULK DYE LOGO EMBELLISHMENT OPTIONS

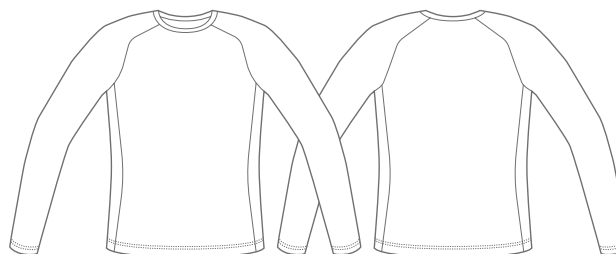

Garment pictured is sublimated, available bulk dye colours are black, navy and red.
Dri Release sublimation finishes with a marle look due to fabric composition.

YOUTH TEAM X POLO

CX5758A

UNISEX SIZE RANGE: 6,8,10,12,14

SUBLIMATION or BULK DYE (black, red and navy)

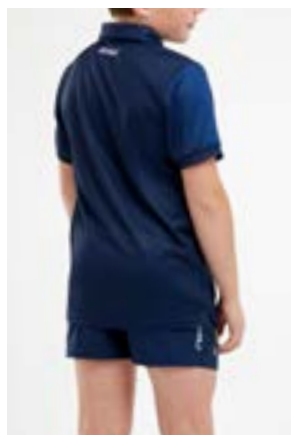

GARMENT FEATURES

01. Semi-fitted, classic style polo.
02. Self fabric collar with two-button placket.
03. Short sleeves with self fabric armbands.
04. Side vents with tennis tail at hem for a full range of motion.
05. Chafe-free flatlock seam construction.
06. Designed for all-round functionality.

FABRIC BENEFITS

HI FIL

Utilising 2XU's breakthrough moisture management technology. Keeps you drier through high-filament yarns and cooler through our advanced knit structure.

Polygiene®

Odour control technology ensures you stay fresh and odour-free. Wear more, wash less and reduce your environmental footprint.

BULK DYE LOGO EMBELLISHMENT OPTIONS

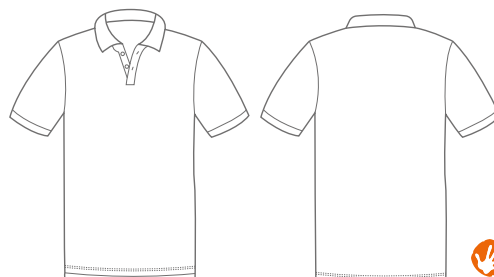

Garment pictured is sublimated, available bulk dye colours are black, navy and red.

YOUTH TEAM X LONGSLEEVE 1/4 ZIP TOP

CX5760A

UNISEX SIZE RANGE: 6,8,10,12,14

SUBLIMATION or BULK DYE (black, red and navy)

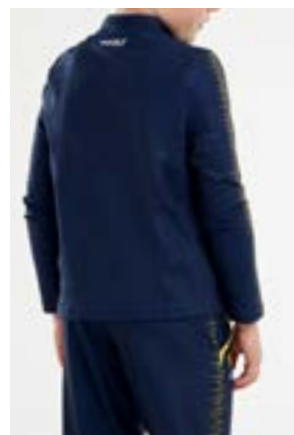

GARMENT FEATURES

01. Semi-fitted style.
02. Long sleeve, set -n sleeve design.
03. Stand-up collar for warmth and protection.
04. 1/4 zip at centre front.
05. Designed for all-round functionality.

FABRIC BENEFITS

3D THERMAL SPHERE LOOP

Utilising 3D high filament polyester knit structure to maximise moisture management and trap heat to keep you warm.

Polygiene®

Odour control technology ensuring you stay fresh and odour free. Wear more, wash less and reduce your environmental footprint.

BULK DYE LOGO EMBELLISHMENT OPTIONS

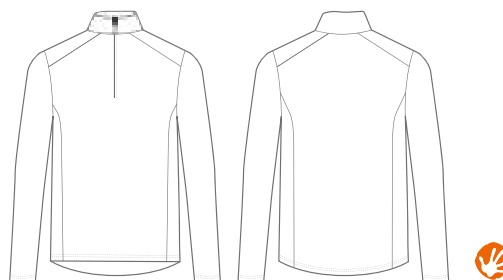

Garment pictured is sublimated, available bulk dye colours are black, navy and red.

YOUTH TEAM X ZIP HOODIE

CX5761A

UNISEX SIZE RANGE: 6,8,10,12,14

SUBLIMATION or BULK DYE (black, red and navy)



GARMENT FEATURES

01. Semi-fitted style.
02. Hood with adjustable bungee cord.
03. Full front zipper.
04. Sleeve and hem cuffs for optimal comfort and fit.
05. Side front pockets.
06. Designed for all-round functionality.

FABRIC BENEFITS

3D THERMAL SPHERE LOOP

Utilising 3D high filament polyester knit structure to maximise moisture management and trap heat to keep you warm.

Polygiene®

Odour control technology ensuring you stay fresh and odour free. Wear more, wash less and reduce your environmental footprint.

BULK DYE LOGO EMBELLISHMENT OPTIONS

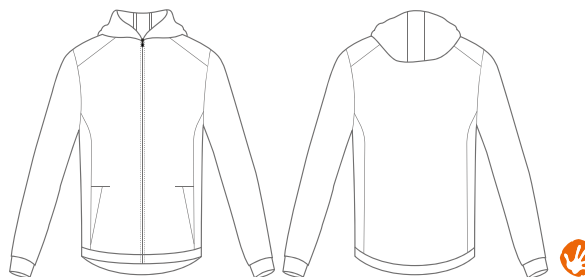

Garment pictured is sublimated, available bulk dye colours are black, navy and red.

YOUTH TEAM X PULLOVER HOODIE

CX5932A

UNISEX SIZE RANGE: 6,8,10,12,14

SUBLIMATION or BULK DYE (black, red and navy)

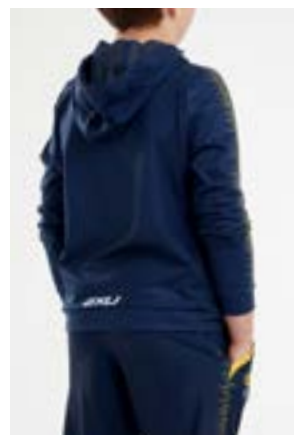

GARMENT FEATURES

01. Semi-fitted pullover style.
02. Hood with adjustable bungee cord.
03. Sleeve and hem cuffs for optimal comfort and fit.
04. Side front pockets.
05. Designed for all-round functionality.

FABRIC BENEFITS

3D THERMAL SPHERE LOOP

Utilising 3D high filament polyester knit structure to maximise moisture management and trap heat to keep you warm.

Polygiene®

Odour control technology ensuring you stay fresh and odour free. Wear more, wash less and reduce your environmental footprint.

BULK DYE LOGO EMBELLISHMENT OPTIONS

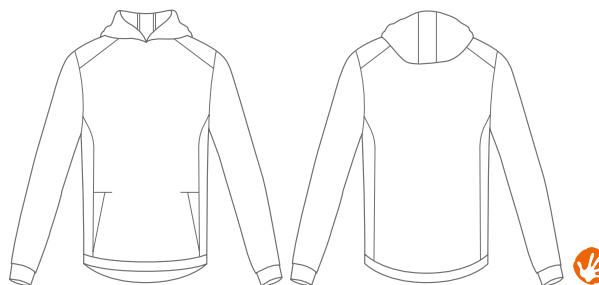

Garment pictured is sublimated, available bulk dye colours are black, navy and red.

YOUTH TEAM X TRACK JACKET

CX5762A

UNISEX SIZE RANGE: 6,8,10,12,14

SUBLIMATION or BULK DYE (black, red and navy)

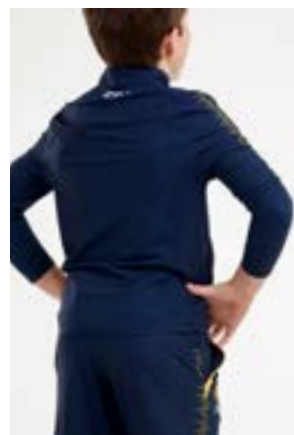

GARMENT FEATURES

01. Semi-fitted style.
02. 4-way stretch for ease of movement and comfort.
03. Stand-up collar for warmth and protection.
04. Full front zipper.
05. Side front zip pockets for convenient storage.
06. Designed for all-round functionality.

FABRIC BENEFITS

VAPOR X STRETCH

2XU's latest technology. Korean-made high gauge woven fabric with a powerful four-way stretch to move with you. High-filament polyester yarn wicks moisture and a DWR water repellent keeps you dry and comfortable. Beautiful hand feel and drape ensure style meets function.

BULK DYE LOGO EMBELLISHMENT OPTIONS

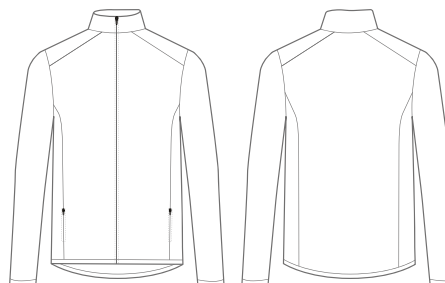

Garment pictured is sublimated, available bulk dye colours are black, navy and red.

YOUTH TEAM X TRACK PANT

CX5763B

UNISEX SIZE RANGE: 6,8,10,12,14

SUBLIMATION or BULK DYE (black, red and navy)



GARMENT FEATURES

01. Semi-fitted style with tapered leg.
02. 4-way stretch for ease of movement and comfort.
03. 4cm width elasticated waist band with a hidden drawcord for a personalised and secure fit.
04. Side front pockets for convenient storage.
05. Designed for all-round functionality.

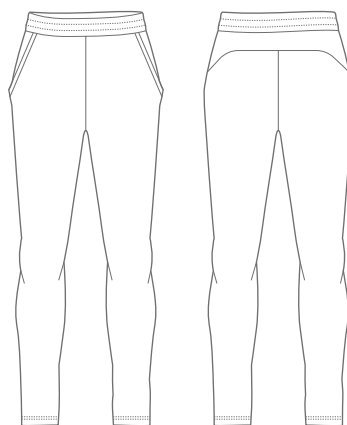

FABRIC BENEFITS

VAPOR X STRETCH

2XU's latest technology. Korean-made high gauge woven fabric with a powerful four-way stretch to move with you. High-filament polyester yarn wicks moisture and a dWR water repellent keeps you dry and comfortable. Beautiful hand feel and drape ensure style meets function.

BULK DYE LOGO EMBELLISHMENT OPTIONS



Garment pictured is sublimated, available bulk dye colours are black, navy and red.

YOUTH TEAM X CASUAL SHORT

CX5764B

UNISEX SIZE RANGE: 6,8,10,12,14

SUBLIMATION or BULK DYE (black, red and navy)



GARMENT FEATURES

01. Straight hem design.
02. 4cm width elasticated waistband with an internal drawcord for a personalised and secure fit.
03. Side front pockets for convenient storage.
04. Designed for all-round functionality.

FABRIC BENEFITS

VAPOR

A lightweight, high-gauge woven fabric with a four-way mechanical stretch. A solution that blocks out wind while remaining light and packable. High-filament yarns wick moisture away from the body to keep the wearer comfortable, dry and with zero cling to the body.

BULK DYE LOGO EMBELLISHMENT OPTIONS

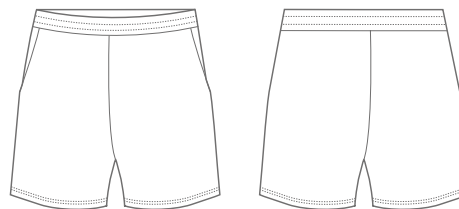

Garment pictured is sublimated, available bulk dye colours are black, navy and red.

ACCESSORIES

TEAM X CUSTOM CASUAL COLLECTION

2XL

SPORT
AUS

ACCESSORIES TEAM X CUSTOM CASUAL COLLECTION

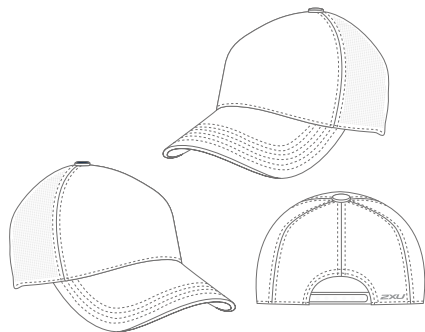

UX5750F
Team X Casual Cap

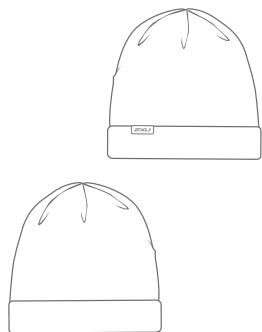

UX5751F
Team X Beanie

TEAM X CASUAL CAP

UX5750F

OSFA

SUBLIMATION, SCREEN PRINT or EMBROIDERY



GARMENT FEATURES

01. Performance sweatband
02. Laser-cut, breathable mesh panelling
03. 7-hole snapback to fit most head sizes
04. 5-panel design
05. Designed for all-round functionality

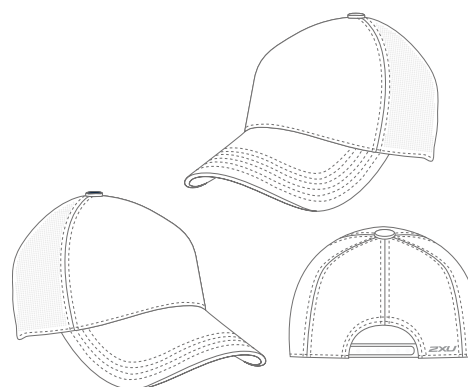

Garment pictured is using embroidery. Screen print and sublimated options are also available.
Casual cap available in 109 different colour options. Contact your sales representative for more information.

TEAM X BEANIE

UX5751F

OSFA

WOVEN PATCH



GARMENT FEATURES

01. Acrylic yarn providing a wool-like texture
02. 5cm foldover providing extra warmth and comfort
03. Customisable woven patch for premium branding
04. Designed for all-round functionality

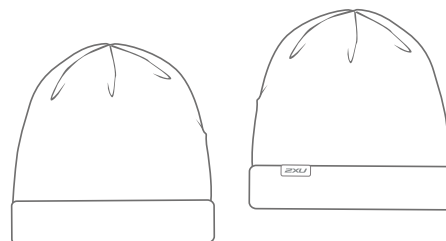

Casual beanie available in 21 different colour options. Contact your sales representative for more information.



SIZE GUIDE

TEAM X CUSTOM CASUAL COLLECTION

TEAM X CUSTOM CASUAL COLLECTION SIZING INFORMATION - MEN'S

MEN'S SIZING

MEASUREMENT (circumference)		2XS	XS	S	M	L	XL	2XL	3XL	4XL	5XL
Chest	cm	83-87	88-92	93- 97	98 -102	103-107	108-112	113-117	118-122	123-127	128-132
	inches	32 ^{5/8} - 34 ^{1/4}	32 ^{5/8} - 34 ^{1/4}	36 ^{5/8} - 38 ^{1/4}	38 ^{5/8} - 40 ^{1/8}	40 ^{1/2} - 42 ^{1/8}	42 ^{1/2} - 44 ^{1/8}	44 ^{1/2} - 46	46 ^{1/2} - 48	48 ^{3/8} - 50	50 ^{3/8} - 52
Waist	cm	65- 69	70-74	75-79	80-84	85-89	90-94	95-99	100-104	105-109	110-114
	inches	25 ^{1/2} - 27 ^{1/8}	27 ^{1/2} - 29 ^{1/8}	29 ^{1/2} - 31 ^{1/8}	31 ^{1/2} - 33	33 ^{1/2} - 35	35 ^{3/8} - 37	37 ^{3/8} - 39	39 ^{3/8} - 41	41 ^{3/8} - 42 ^{7/8}	43 ^{3/8} - 44 ^{7/8}



Levi is 188cm, 82kgs and wears a Medium

TEAM X CUSTOM CASUAL COLLECTION SIZING INFORMATION - WOMEN'S

WOMEN'S SIZING

MEASUREMENT (circumference)		2XS	XS	S	M	L	XL	2XL	3XL	4XL
Chest	cm	78-82	83-87	88-92	93 - 97	98 -102	103-107	108-112	113-117	118-122
	inches	30 ³ / ₄ - 32 ¹ / ₄	32 ⁵ / ₈ - 34 ¹ / ₄	34 ⁵ / ₄ - 36 ¹ / ₄	36 ⁵ / ₈ - 38 ¹ / ₄	38 ⁵ / ₈ - 40 ¹ / ₄	40 ¹ / ₂ - 42 ¹ / ₈	42 ¹ / ₂ - 44 ¹ / ₈	44 ¹ / ₂ - 46	46 ¹ / ₂ - 48
Waist	cm	58-62	63-67	68-72	73-77	78-82	83-87	88-92	93-97	98-102
	inches	22 ³ / ₄ - 24 ³ / ₈	24 ³ / ₄ - 26 ³ / ₈	26 ³ / ₄ - 28 ³ / ₈	28 ³ / ₄ - 30 ³ / ₈	30 ³ / ₄ - 32 ¹ / ₄	32 ³ / ₄ - 34 ¹ / ₄	34 ⁵ / ₈ - 36 ¹ / ₄	36 ⁵ / ₈ - 38 ¹ / ₄	38 ⁵ / ₈ - 40 ¹ / ₈
Hip	cm	86-90	91-95	96-100	101-105	106-110	111-115	116-120	121-125	126-130
	inches	33 ⁷ / ₈ - 35 ¹ / ₂	35 ⁷ / ₈ - 37 ³ / ₈	37 ³ / ₄ - 39 ³ / ₈	39 ³ / ₄ - 41 ³ / ₈	41 ³ / ₄ - 43 ³ / ₈	43 ³ / ₄ - 45 ¹ / ₄	45 ⁵ / ₈ - 47 ¹ / ₄	47 ⁵ / ₈ - 49 ¹ / ₄	49 ⁵ / ₈ - 51 ¹ / ₄



Emma is 180cm, 64kgs and wears a Small

TEAM X CUSTOM CASUAL COLLECTION SIZING INFORMATION - YOUTH

YOUTH UNISEX SIZING

MEASUREMENT (circumference)		6	8	10	12	14
Chest	cm	58-62	63-68	69-74	75-77	79-81
	inches	22 ^{3/4} -24 ^{1/2}	24 ^{3/4} -26 ^{3/4}	27 ^{1/8} -29 ^{1/8}	29 ^{1/2} -30 ^{1/4}	31-32
Waist	cm	56-58	59-62	63-66	67-69	70-74
	inches	22-22 ^{3/4}	23 ^{1/4} -24 ^{1/2}	24 ^{3/4} -26	26 ^{3/8} -27 ^{1/4}	27 ^{1/2} -29



CUSTOM CYCLE COLLECTION



2XU
C U S T O M



50M **2XU**
C U S T O M

THE NEW **2XU CUSTOM CYCLE COLLECTION** HAS BEEN EXCLUSIVELY ENGINEERED IN PARTNERSHIP WITH **JELLY BELLY PRO CYCLING TEAM.**



CYCLING TEAM

“ The 2XU race skinsuit provides a great fit in a very aerodynamic package that still has pockets for those really long races. ”

“ As athletes we're always too cold, or too hot and are always modifying a piece of clothing with a pair of scissors. At Jelly Belly Pro Cycling we were able to work directly with 2XU to create a range of products that more than encompasses the gamut of weather conditions we experience when racing and training and in a fit that is comfortable, aerodynamic and looks amazing. I've no longer a need for my scissors. ”

“ I really enjoy wearing the lightweight 2XU summer jersey on those hot days in the big mountains. Staying cool and comfortable makes all the difference in the long stage races that the Jelly Belly Pro Cycling Team partakes in. ”

- JELLY BELLY PRO CYCLING TEAM

CUSTOM CYCLING FABRIC TECHNICAL INFORMATION

The Custom Cycling collection has been engineered to deliver enhanced comfort and aerodynamics. The collection delivers world leading cycling garment technology for first class performance.

KINETIC POWER

Engineered specifically for cycle. This durable, high denier nylon elastane knit provides increased power through higher muscle holding ability.

KINETIC SPEED

Swiss-made Kinetic Speed, with golf ball air trapping performance for increased aerodynamics.

VAPOR

Lightweight stretch high gauge woven fabric that blocks out the wind while staying light and packable.

HI~FILXTREME

High filament polyester yarns provides extreme moisture management and breathability, while the brushed inner delivers warmth and comfort.

FLXPRO

Utilising a polyester elastane blend to provide essential stretch and recovery.

SMD

High filament yarns in a mesh knit structure to ensure moisture control.

HI~FILVENT+

A high filament polyester yarn created into a cycle-specific vent knit structure to optimise ventilation and improve aerodynamics. Polygiene® antibacterial for lifetime odour elimination.

ITALIASUB

Italian-made and engineered specifically for cycle. This sublimation fabric offers customisation, extreme moisture management and high filament yarns to ensure extra comfort.

HI~FIL+

A performance fabric using high filament technology for maximum moisture management. Cross channelled yarns wick vapour from the inner to outer layers to keep the wearer dry and comfortable. Polygiene® antibacterial for lifetime odour elimination.

2X20K

Lightweight and flexible PU membrane that provides 20k waterproofing and 20k moisture vapour transfer. This fabric features a high filament jersey backing for comfort.

CUSTOM CYCLING FABRIC TECHNICAL INFORMATION

ICE X

Cooling technology that actively lowers skin temperature when contact is made with the skin. The fabric weave also blocks IR and UV rays for added sun protection.

ICE X MESH

ICE X MESH technology draws heat from the body and lowers skin temperature by up to 3°C / 5.4°F. The ultimate solution for endurance demands, ICE X MESH will keep athletes cool through the harshest conditions.

VELO HEAT

Italian-made high filament brushed polyester to encourage the perfect microclimate. The high gauge knit provides dryness and warmth, while the brushed backing traps heat. The high filament x section yarns aid dryness.

VELO MESH

High filament yarns in a mesh knit structure which aids cooling and moisture control.

VELOPRO HEAT

High filament yarn coupled with high density Lycra yarn gives high power, durability and breathability. The brushed backing traps heat for warmth and increases moisture management.

HI FIL VELO

An Italian-made, cycle-specific HI FIL VELO performance fabric engineered for maximum moisture management. Cross channelled yarns wick vapour from the inner to the outer layers to keep the wearer dry and comfortable, while the mesh structure promotes breathability.

VELO POWER

Velo Power utilises Italian-made high-filament nylon yarns, coupled with high denier elastane fibres for exceptional durability and muscle holding ability.

SENSOR MESH

Utilising a polyester-elastane breathable matrix for optimal air flow for the ultimate in moisture management.



MEN'S

CUSTOM CYCLE COLLECTION

MEN'S CUSTOM CYCLE COLLECTION

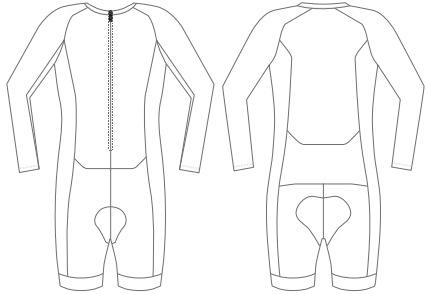

MX4974D
Men's Longsleeve Cycle Skinsuit

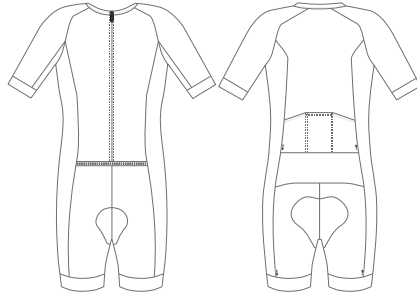

MX4972D
Men's Cycle Skinsuit

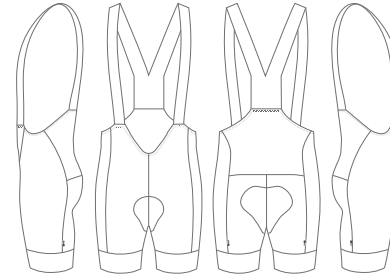

MX4954B
Men's Elite Cycle Bib Shorts

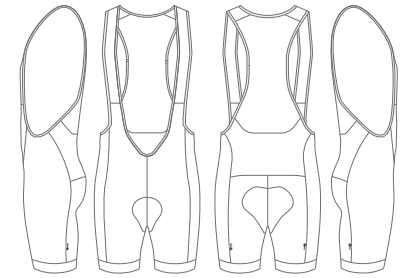

MX4960B
Men's Perform Cycle Bib Shorts

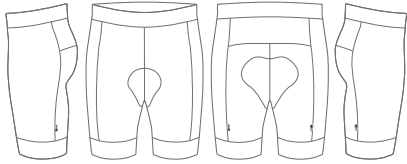

MX4956B
Men's Elite Cycle Shorts

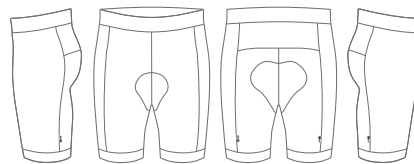

MX4962B
Men's Perform Cycle Shorts

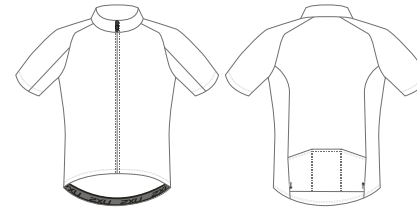

MX4952A
Men's Elite Cycle Jersey

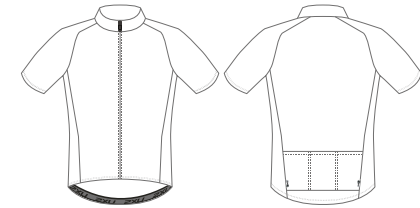

MX4958A
Men's Perform Cycle Jersey

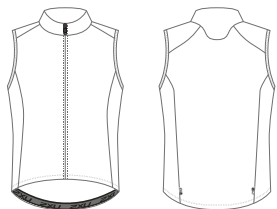

MX4966A
Men's Spring Cycle Gilet

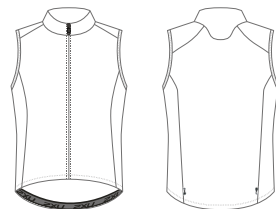

MX4968A
Men's Wind Defence Cycle Gilet

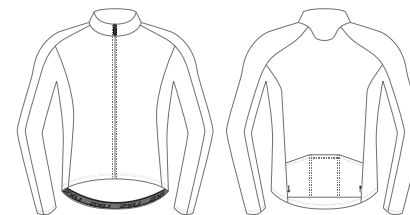

MX4964A
Men's Thermal Longsleeve Cycle Jersey

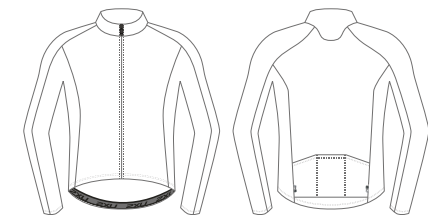

MX4970A
Men's Wind Defence Cycle Jacket

MEN'S LONGSLEEVE CYCLE SKINSUIT

MX4974D

SUBLIMATION/BULK DYE

SIZE RANGE: 2XS - 5XL

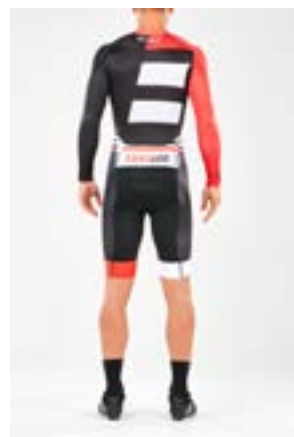

GARMENT FEATURES

01. ACF: Anatomical Cycle Fit
02. Alta Badia chamois
03. Reflective trims for visibility
04. Rear pockets for storage
05. 75mm wide Italian leg grippers for performance and comfort

BULK DYE COLOUR OPTIONS

- Black
- Navy 282C
- Bluette 2728C
- Red 186C
- Gunmetal Grey 18-0201 TPX
- White

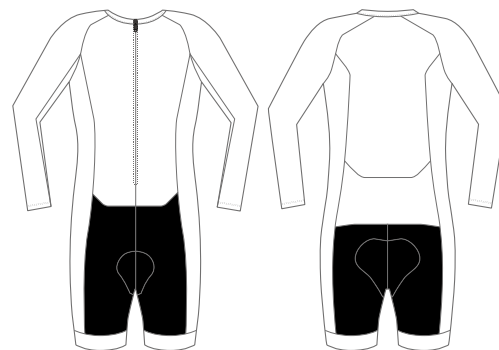

*Areas highlighted in black denotes bulk dye fabric.

FABRIC BENEFITS

01. VELO POWER
Velo Power utilises Italian-made high-filament nylon yarns, coupled with high denier elastane fibres for exceptional durability and muscle holding ability.
02. KINETIC SPEED
Swiss-made Kinetic Speed, with golf ball air trapping performance for increased aerodynamics.
03. ICE X MESH
Draws heat from the body and lowers skin temperature by up to 3°C / 5.4°F. The ultimate solution for endurance demands, ICE X MESH will keep athletes cool through the harshest conditions.
04. ICE X
Offering superior cooling performance with support and moisture control, ICE X utilises a high filament polyester cooling yarn construction to lower body temperature when working out. This is supported by powerful elastane yarns that provides the right amount of stretch and recovery for cycling.
05. ALTA BADIA CHAMOIS
Italian-made maximum 120 density foam chamois with multi-zoned padding and pre-shaped technology to provide ultimate comfort. Engineered as a seamless one-piece design, perforated for excellent breathability and enhanced moisture management, with a low profile outer edge to prevent chafing. Antibacterial protection has been added for anti-odour control.

MEN'S CYCLE SKINSUIT

MX4972D

SUBLIMATION/BULK DYE

SIZE RANGE: 2XS - 5XL

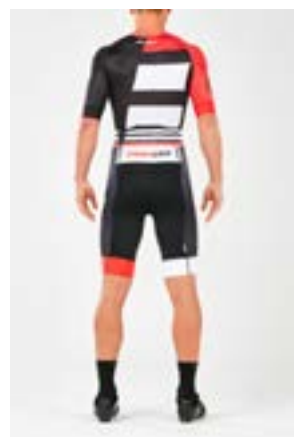

GARMENT FEATURES

01. ACF: Anatomical Cycle Fit
02. Alta Badia chamois
03. Reflective trims for visibility
04. Rear pockets for storage
05. 75mm wide Italian leg grippers for performance and comfort

BULK DYE COLOUR OPTIONS

- Black
- Navy 282C
- Bluette 2728C
- Red 186C
- Gunmetal Grey 18-0201 TPX
- White

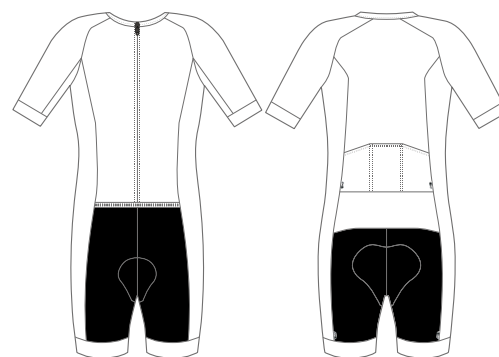

*Areas highlighted in black denotes bulk dye fabric.

FABRIC BENEFITS

01. VELO POWER
Velo Power utilises Italian-made high-filament nylon yarns, coupled with high denier elastane fibres for exceptional durability and muscle holding ability.
02. KINETIC SPEED
Swiss-made Kinetic Speed, with golf ball air trapping performance for increased aerodynamics.
03. ICE X MESH
Draws heat from the body and lowers skin temperature by up to 3°C / 5.4°F. The ultimate solution for endurance demands, ICE X MESH will keep athletes cool through the harshest conditions.
04. ICE X
Offering superior cooling performance with support and moisture control, ICE X utilises a high filament polyester cooling yarn construction to lower body temperature when working out. This is supported by powerful elastane yarns that provides the right amount of stretch and recovery for cycling.
05. ALTA BADIA CHAMOIS
Italian-made maximum 120 density foam chamois with multi-zoned padding and pre-shaped technology to provide ultimate comfort. Engineered as a seamless one-piece design, perforated for excellent breathability and enhanced moisture management, with a low profile outer edge to prevent chafing. Antibacterial protection has been added for anti-odour control.

Levi is 188cm, 82kgs and wears a Medium

MEN'S ELITE CYCLE BIB SHORTS

MX4954B

SUBLIMATION/BULK DYE

SIZE RANGE: 2XS - 5XL



GARMENT FEATURES

01. ACF: Anatomical Cycle Fit
02. Alta Badia chamois
03. Reflective trims for visibility
04. 75mm wide Italian leg gripper for performance and comfort
05. Italian-engineered low profile one-piece bib strap for ultimate comfort

BULK DYE COLOUR OPTIONS

- Black
- Navy 282C
- Bluette 2728C
- Red 186C
- Gunmetal Grey 18-0201 TPX
- White

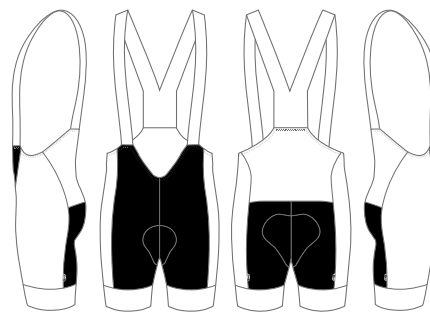

*Areas highlighted in black denotes bulk dye fabric.

FABRIC BENEFITS

01. VELO POWER
Velo Power utilises Italian-made high-filament nylon yarns, coupled with high denier elastane fibres for exceptional durability and muscle holding ability.
02. ITALIA SUB
Italian-made and engineered specifically for cycle. This sublimation fabric offers customisation, extreme moisture management and high filament yarns to ensure extra comfort.
03. ALTA BADIA CHAMOIS
Italian-made maximum 120 density foam chamois with multi-zoned padding and pre-shaped technology to provide ultimate comfort. Engineered as a seamless one-piece design, perforated for excellent breathability and enhanced moisture management, with a low profile outer edge to prevent chafing. Antibacterial protection has been added for anti-odour control.

MEN'S PERFORM CYCLE BIB SHORTS

MX4960B

SUBLIMATION/BULK DYE

SIZE RANGE: 2XS - 5XL

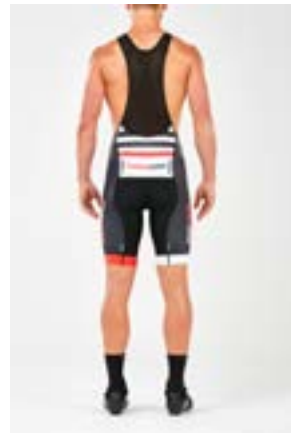

GARMENT FEATURES

01. ACF: Anatomical Cycle Fit
02. Stelvio chamois
03. Reflective trims for visibility
04. 48mm wide Italian leg gripper for performance and comfort
05. Mesh bib strap with low profile binding for comfort

BULK DYE COLOUR OPTIONS

- Black
- Navy 282C
- Reflex Blue C
- Red 186C
- Gunmetal Grey 18-0201 TPX
- White

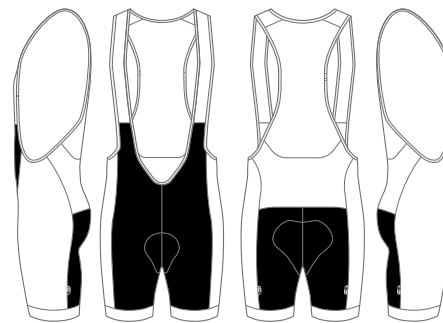

*Areas highlighted in black denotes bulk dye fabric.

FABRIC BENEFITS

01. KINETIC POWER
Engineered specifically for cycle. This durable, high denier nylon elastane knit provides increased power through higher muscle holding ability.
02. ITALIA SUB
Italian-made and engineered specifically for cycle. This sublimation fabric offers customisation, extreme moisture management and high filament yarns to ensure extra comfort.
03. SENSOR MESH
Utilising a polyester-elastane breathable matrix for optimal air flow for the ultimate in moisture management.

MEN'S ELITE CYCLE SHORTS

MX4956B

SUBLIMATION/BULK DYE

SIZE RANGE: 2XS - 5XL

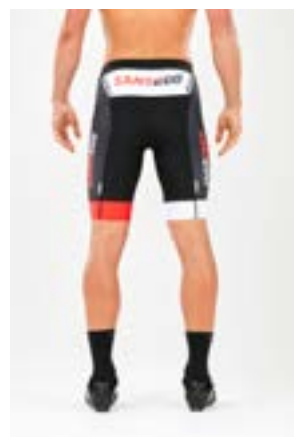
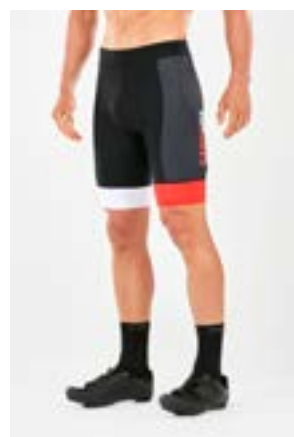

GARMENT FEATURES

01. ACF: Anatomical Cycle Fit
02. Alta Badia chamois
03. Reflective trims for visibility
04. 75mm wide Italian leg gripper for performance and comfort

BULK DYE COLOUR OPTIONS

- Black
- Navy 282C
- Bluette 2728C
- Red 186C
- Gunmetal Grey 18-0201 TPX
- White

FABRIC BENEFITS

01. VELO POWER
Velo Power utilises Italian-made high-filament nylon yarns, coupled with high denier elastane fibres for exceptional durability and muscle holding ability.
02. ITALIA SUB
Italian-made and engineered specifically for cycle. This sublimation fabric offers customisation, extreme moisture management and high filament yarns to ensure extra comfort.
03. ALTA BADIA CHAMOIS
Italian-made maximum 120 density foam chamois with multi-zoned padding and pre-shaped technology to provide ultimate comfort. Engineered as a seamless one-piece design, perforated for excellent breathability and enhanced moisture management, with a low profile outer edge to prevent chafing. Antibacterial protection has been added for anti-odour control.

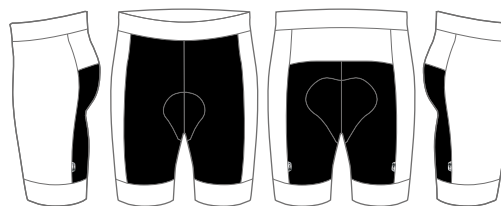

*Areas highlighted in black denotes bulk dye fabric.

Levi is 188cm, 82kgs and wears a Medium

MEN'S PERFORM CYCLE SHORTS

MX4962B

SUBLIMATION/BULK DYE

SIZE RANGE: 2XS - 5XL

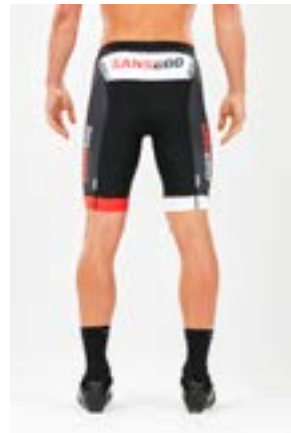
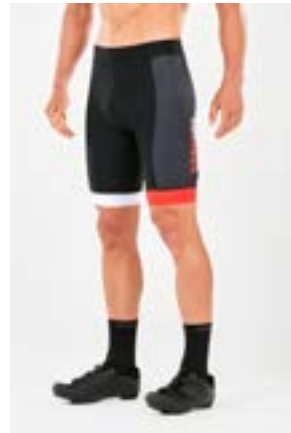

GARMENT FEATURES

01. ACF: Anatomical Cycle Fit
02. Stelvio chamois
03. Reflective trims for visibility
04. 48mm wide Italian leg gripper for performance and comfort

BULK DYE COLOUR OPTIONS

- Black
- Navy 282C
- Reflex Blue C
- Red 186C
- Gunmetal Grey 18-0201 TPX
- White

FABRIC BENEFITS

01. KINETIC POWER
Engineered specifically for cycle. This durable, high denier nylon elastane knit provides increased power through higher muscle holding ability.
02. ITALIA SUB
Italian-made and engineered specifically for cycle. This sublimation fabric offers customisation, extreme moisture management and high filament yarns to ensure extra comfort.
03. SENSOR MESH
Utilising a polyester-elastane breathable matrix for optimal air flow for the ultimate in moisture management.

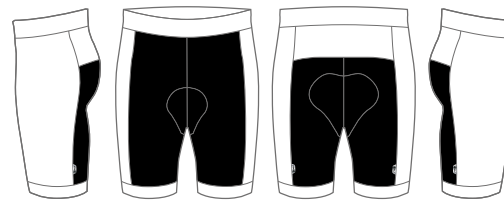

*Areas highlighted in black denotes bulk dye fabric.

Levi is 188cm, 82kgs and wears a Medium

MEN'S ELITE CYCLE JERSEY

MX4952A

SUBLIMATION

SIZE RANGE: 2XS - 5XL



GARMENT FEATURES

01. ACF: Anatomical Cycle Fit
02. Reflective trims for visibility
03. Rear pockets for storage

FABRIC BENEFITS

01. HI FIL VELO
An Italian-made, cycle-specific HI FIL VELO performance fabric engineered for maximum moisture management. Cross channelled yarns wick vapour from the inner to the outer layers to keep the wearer dry and comfortable, while the mesh structure promotes breathability.
02. VELO MESH
High-filament yarns in a mesh knit structure to aid cooling and moisture control.

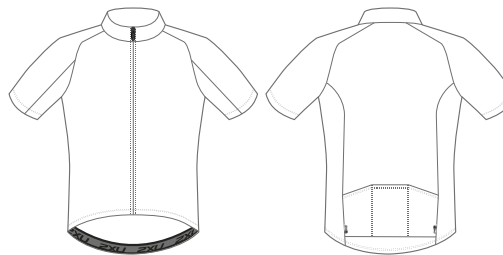

Levi is 188cm, 82kgs and wears a Medium

MEN'S PERFORM CYCLE JERSEY

MX4958A

SUBLIMATION

SIZE RANGE: 2XS - 5XL



GARMENT FEATURES

01. ACF: Anatomical Cycle Fit
02. Reflective trims for visibility
03. Rear pockets for storage
04. Polygiene® antibacterial for lifetime odour elimination

FABRIC BENEFITS

01. HI FIL+
A performance fabric using high filament technology for maximum moisture management. Cross channelled yarns wick vapour from the inner to outer layers to keep the wearer dry and comfortable. Polygiene® antibacterial for lifetime odour elimination.
02. HI FIL VENT+
A high filament polyester yarn created into a cycle-specific vent knit structure to optimise ventilation and improve aerodynamics. Polygiene® antibacterial for lifetime odour elimination.

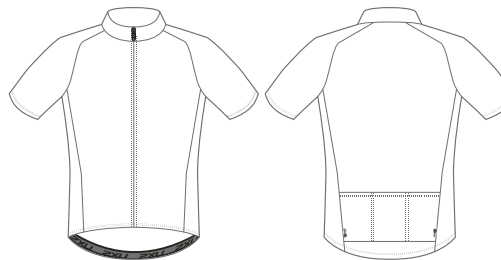

Levi is 188cm, 82kgs and wears a Medium

MEN'S SPRING CYCLE GILET

MX4966A

SUBLIMATION

SIZE RANGE: 2XS - 5XL



GARMENT FEATURES

01. ACF: Anatomical Cycle Fit
02. Reflective trims for visibility

FABRIC BENEFITS

01. VAPOR STRETCH
Lightweight stretch high gauge woven fabric that blocks out the wind while staying light and packable.
02. SENSOR MESH
Utilising a polyester-elastane breathable matrix for optimal air flow for the ultimate in moisture management.

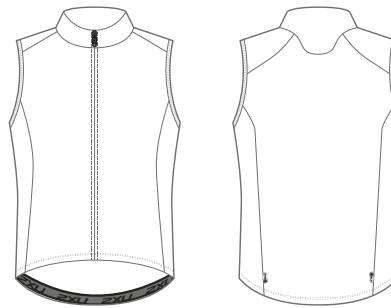

Levi is 188cm, 82kgs and wears a Medium

MEN'S WIND DEFENCE CYCLE GILET

MX4968A

SUBLIMATION

SIZE RANGE: 2XS - 5XL



GARMENT FEATURES

01. ACF: Anatomical Cycle Fit
02. Reflective trims for visibility

FABRIC BENEFITS

01. 2X 20K STRETCH
Lightweight and flexible PU membrane that provides 20k waterproofing and 20k moisture vapour transfer. This fabric features a high filament jersey backing for comfort.
02. SENSOR MESH
Utilising a polyester-elastane breathable matrix for optimal air flow for the ultimate in moisture management.

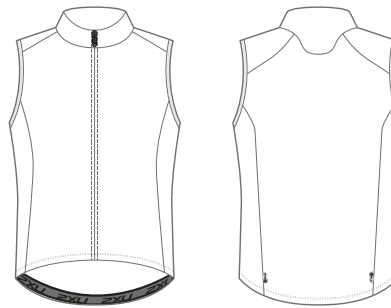

Levi is 188cm, 82kgs and wears a Medium

MEN'S THERMAL LONGSLEEVE CYCLE JACKET

MX4964A

SUBLIMATION

SIZE RANGE: 2XS - 5XL



GARMENT FEATURES

01. ACF: Anatomical Cycle Fit
02. Reflective trims for visibility
03. Rear pockets for storage

FABRIC BENEFITS

01. VELO HEAT
Italian-made high filament brushed polyester to encourage the perfect microclimate. The high gauge knit provides dryness and warmth, while the brushed backing traps heat. The high filament x section yarns aid dryness.

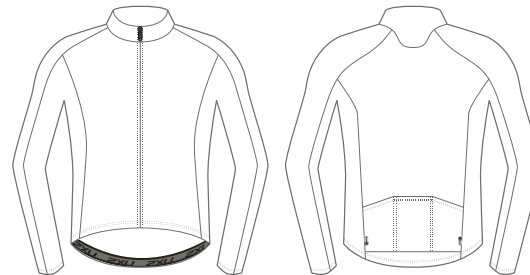

Levi is 188cm, 82kgs and wears a Medium

MEN'S WIND DEFENCE CYCLE JACKET

MX4970A

SUBLIMATION

SIZE RANGE: 2XS - 5XL



GARMENT FEATURES

01. ACF: Anatomical Cycle Fit
02. Reflective trims for visibility
03. Rear pockets for storage

FABRIC BENEFITS

01. 2X 20K STRETCH
Lightweight and flexible PU membrane that provides 20k waterproofing and 20k moisture vapour transfer. This fabric features a high filament jersey backing for comfort.

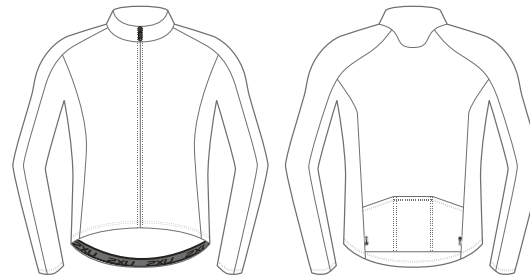

Levi is 188cm, 82kgs and wears a Medium



WOMEN'S

CUSTOM CYCLE COLLECTION

WOMEN'S CUSTOM CYCLE COLLECTION

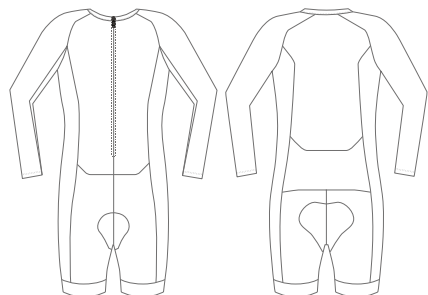

WX4975D

Women's Longsleeve Cycle Skinsuit

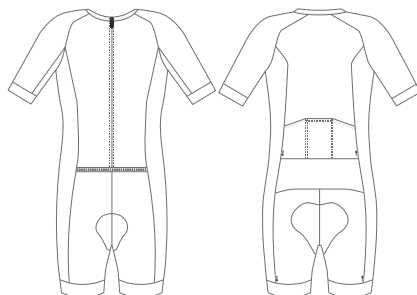

WX4973D

Women's Cycle Skinsuit

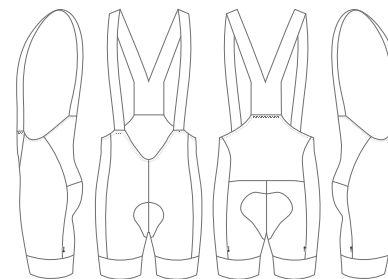

WX4955B

Women's Elite Cycle Bib Shorts

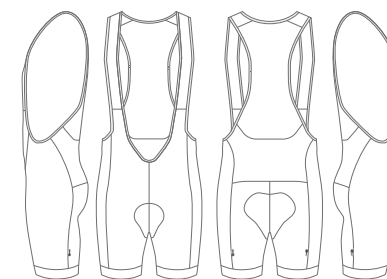

WX4961B

Women's Perform Cycle Bib Shorts

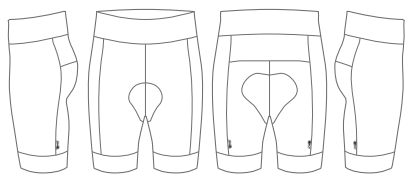

WX4957B

Women's Elite Cycle Shorts

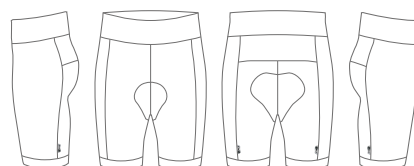

WX4963B

Women's Perform Cycle Shorts

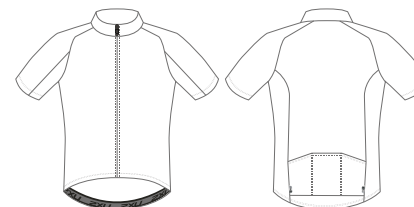

WX4953A

Women's Elite Cycle Jersey

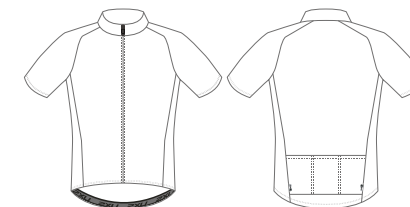

WX4959A

Women's Perform Cycle Jersey

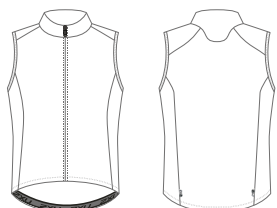

WX4967A

Women's Spring Cycle Gilet

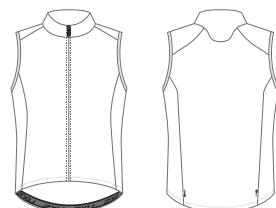

WX4969A

Women's Wind Defence Cycle Gilet

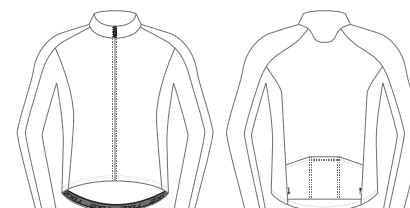

WX4965A

Women's Thermal Longsleeve Cycle Jersey

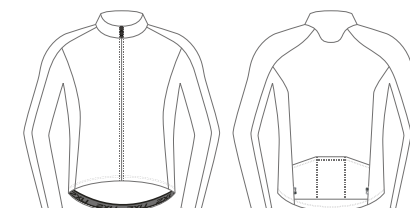

WX4971A

Women's Wind Defence Cycle Jacket

WOMEN'S LONGSLEEVE CYCLE SKINSUIT

WX4975D

SUBLIMATION/BULK DYE

SIZE RANGE: 2XS - 4XL

Steph is 182cm, 64kgs and wears a Small

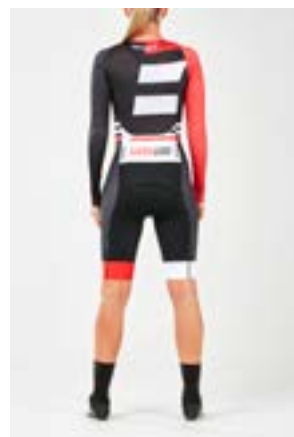

GARMENT FEATURES

01. ACF: Anatomical Cycle Fit
02. Alta Badia chamois
03. Reflective trims for visibility
04. Rear pockets for storage
05. 75mm wide Italian leg grippers for performance and comfort

BULK DYE COLOUR OPTIONS

- Black
- Navy 282C
- Bluette 2728C
- Red 186C
- Gunmetal Grey 18-0201 TPX
- White

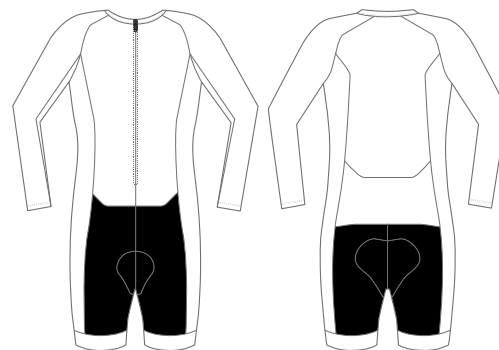

*Areas highlighted in black denotes bulk dye fabric.

FABRIC BENEFITS

01. VELO POWER
Velo Power utilises Italian-made high-filament nylon yarns, coupled with high denier elastane fibres for exceptional durability and muscle holding ability.
02. KINETIC SPEED
Swiss-made Kinetic Speed, with golf ball air trapping performance for increased aerodynamics.
03. ICE X MESH
Draws heat from the body and lowers skin temperature by up to 3°C / 5.4°F. The ultimate solution for endurance demands, ICE X MESH will keep athletes cool through the harshest conditions.
04. ICE X
Offering superior cooling performance with support and moisture control, ICE X utilises a high filament polyester cooling yarn construction to lower body temperature when working out. This is supported by powerful elastane yarns that provides the right amount of stretch and recovery for cycling.
05. ALTA BADIA CHAMOIS
Italian-made maximum 120 density foam chamois with multi-zoned padding and pre-shaped technology to provide ultimate comfort. Engineered as a seamless one-piece design, perforated for excellent breathability and enhanced moisture management, with a low profile outer edge to prevent chafing. Antibacterial protection has been added for anti-odour control.

WOMEN'S CYCLE SKINSUIT

WX4973D

SUBLIMATION/BULK DYE

SIZE RANGE: 2XS - 4XL

Steph is 182cm, 64kgs and wears a Small



GARMENT FEATURES

01. ACF: Anatomical Cycle Fit
02. Alta Badia chamois
03. Reflective trims for visibility
04. Rear pockets for storage
05. 75mm wide Italian leg grippers for performance and comfort

BULK DYE COLOUR OPTIONS

- Black
- Navy 282C
- Bluette 2728C
- Red 186C
- Gunmetal Grey 18-0201 TPX
- White

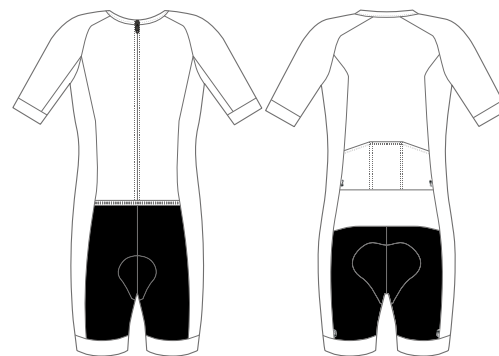

*Areas highlighted in black denotes bulk dye fabric.

FABRIC BENEFITS

01. VELO POWER
Velo Power utilises Italian-made high-filament nylon yarns, coupled with high denier elastane fibres for exceptional durability and muscle holding ability.
02. KINETIC SPEED
Swiss-made Kinetic Speed, with golf ball air trapping performance for increased aerodynamics.
03. ICE X MESH
Draws heat from the body and lowers skin temperature by up to 3°C / 5.4°F. The ultimate solution for endurance demands, ICE X MESH will keep athletes cool through the harshest conditions.
04. ICE X
Offering superior cooling performance with support and moisture control, ICE X utilises a high filament polyester cooling yarn construction to lower body temperature when working out. This is supported by powerful elastane yarns that provides the right amount of stretch and recovery for cycling.
05. ALTA BADIA CHAMOIS
Italian-made maximum 120 density foam chamois with multi-zoned padding and pre-shaped technology to provide ultimate comfort. Engineered as a seamless one-piece design, perforated for excellent breathability and enhanced moisture management, with a low profile outer edge to prevent chafing. Antibacterial protection has been added for anti-odour control.

WOMEN'S ELITE CYCLE BIB SHORTS

WX4955B

SUBLIMATION/BULK DYE

SIZE RANGE: 2XS - 4XL

Steph is 182cm, 64kgs and wears a Small



GARMENT FEATURES

01. ACF: Anatomical Cycle Fit
02. Alta Badia chamois
03. Reflective trims for visibility
04. 75mm wide Italian leg gripper for performance and comfort
05. Italian-engineered low profile one-piece bib strap for ultimate comfort

BULK DYE COLOUR OPTIONS

- Black
- Navy 282C
- Bluette 2728C
- Red 186C
- Gunmetal Grey 18-0201 TPX
- White

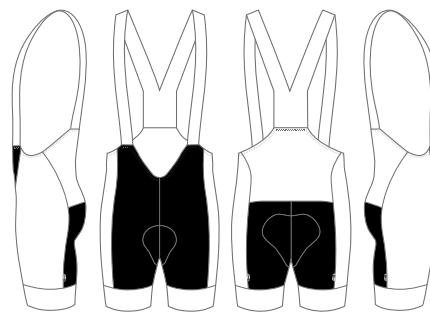

*Areas highlighted in black denotes bulk dye fabric.

FABRIC BENEFITS

01. VELO POWER
Velo Power utilises Italian-made high-filament nylon yarns, coupled with high denier elastane fibres for exceptional durability and muscle holding ability.
02. ITALIA SUB
Italian-made and engineered specifically for cycle. This sublimation fabric offers customisation, extreme moisture management and high filament yarns to ensure extra comfort.
03. ALTA BADIA CHAMOIS
Italian-made maximum 120 density foam chamois with multi-zoned padding and pre-shaped technology to provide ultimate comfort. Engineered as a seamless one-piece design, perforated for excellent breathability and enhanced moisture management, with a low profile outer edge to prevent chafing. Antibacterial protection has been added for anti-odour control.

WOMEN'S PERFORM CYCLE BIB SHORTS

WX4961B

SUBLIMATION/BULK DYE

SIZE RANGE: 2XS - 4XL

Steph is 182cm, 64kgs and wears a Small

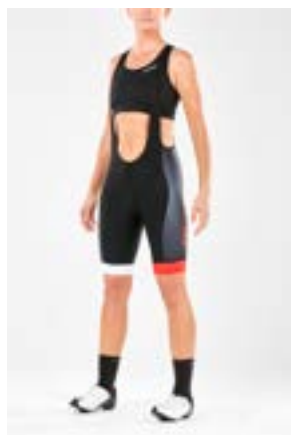

GARMENT FEATURES

01. ACF: Anatomical Cycle Fit
02. Stelvio chamois
03. Reflective trims for visibility
04. 48mm wide Italian leg gripper for performance and comfort
05. Mesh bib strap with low profile binding for comfort

BULK DYE COLOUR OPTIONS

- Black
- Navy 282C
- Reflex Blue C
- Red 186C
- Gunmetal Grey 18-0201 TPX
- White

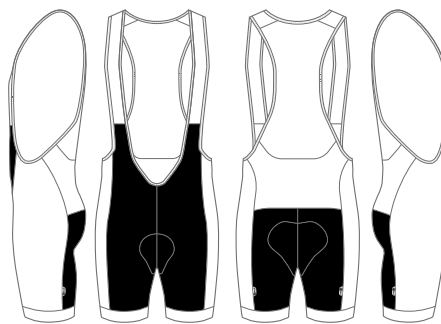

*Areas highlighted in black denotes bulk dye fabric.

FABRIC BENEFITS

01. KINETIC POWER
Engineered specifically for cycle. This durable, high denier nylon elastane knit provides increased power through higher muscle holding ability.
02. ITALIA SUB
Italian-made and engineered specifically for cycle. This sublimation fabric offers customisation, extreme moisture management and high filament yarns to ensure extra comfort.
03. SENSOR MESH
Utilising a polyester-elastane breathable matrix for optimal air flow for the ultimate in moisture management.

WOMEN'S ELITE CYCLE SHORTS

WX4957B

SUBLIMATION/BULK DYE

SIZE RANGE: 2XS - 4XL

Steph is 182cm, 64kgs and wears a Small



GARMENT FEATURES

01. ACF: Anatomical Cycle Fit
02. Alta Badia chamois
03. Reflective trims for visibility
04. 75mm wide Italian leg gripper for performance and comfort

BULK DYE COLOUR OPTIONS

- Black
- Navy 282C
- Bluette 2728C
- Red 186C
- Gunmetal Grey 18-0201 TPX
- White

FABRIC BENEFITS

VELO POWER

Velo Power utilises Italian-made high-filament nylon yarns, coupled with high denier elastane fibres for exceptional durability and muscle holding ability.

01. ITALIA SUB

Italian-made and engineered specifically for cycle. This sublimation fabric offers customisation, extreme moisture management and high filament yarns to ensure extra comfort.

02. ALTA BADIA CHAMOIS

Italian-made maximum 120 density foam chamois with multi-zoned padding and pre-shaped technology to provide ultimate comfort. Engineered as a seamless one-piece design, perforated for excellent breathability and enhanced moisture management, with a low profile outer edge to prevent chafing. Antibacterial protection has been added for anti-odour control.

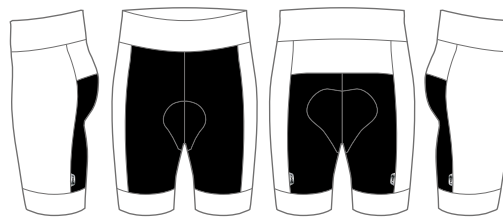

*Areas highlighted in black denotes bulk dye fabric.

WOMEN'S PERFORM CYCLE SHORTS

WX4963B

SUBLIMATION/BULK DYE

SIZE RANGE: 2XS - 4XL

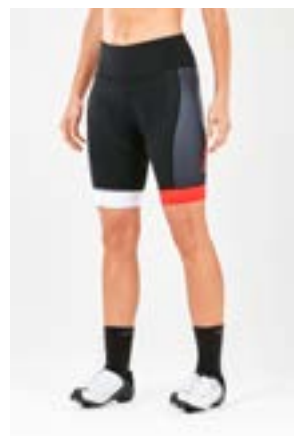

GARMENT FEATURES

01. ACF: Anatomical Cycle Fit
02. Stelvio chamois
03. Reflective trims for visibility
04. 48mm wide Italian leg gripper for performance and comfort

BULK DYE COLOUR OPTIONS

- Black
- Navy 282C
- Reflex Blue C
- Red 186C
- Gunmetal Grey 18-0201 TPX
- White

FABRIC BENEFITS

01. KINETIC POWER
Engineered specifically for cycle. This durable, high denier nylon elastane knit provides increased power through higher muscle holding ability.
02. ITALIA SUB
Italian-made and engineered specifically for cycle. This sublimation fabric offers customisation, extreme moisture management and high filament yarns to ensure extra comfort.
03. SENSOR MESH
Utilising a polyester-elastane breathable matrix for optimal air flow for the ultimate in moisture management.

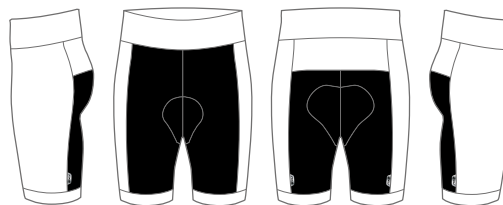

*Areas highlighted in black denotes bulk dye fabric.

Steph is 182cm, 64kgs and wears a Small

WOMEN'S ELITE CYCLE JERSEY

WX4953A

SUBLIMATION

SIZE RANGE: 2XS - 4XL

Steph is 182cm, 64kgs and wears a Small

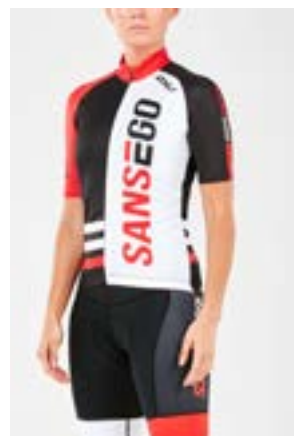

GARMENT FEATURES

01. ACF: Anatomical Cycle Fit
02. Reflective trims for visibility
03. Rear pockets for storage

FABRIC BENEFITS

01. HI FIL VELO
An Italian-made, cycle-specific HI FIL VELO performance fabric engineered for maximum moisture management. Cross channelled yarns wick vapour from the inner to the outer layers to keep the wearer dry and comfortable, while the mesh structure promotes breathability.
02. VELO MESH
High-filament yarns in a mesh knit structure to aid cooling and moisture control.

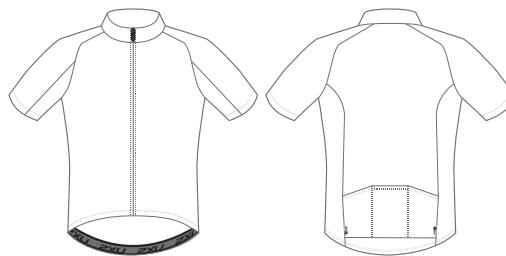

WOMEN'S PERFORM CYCLE JERSEY

WX4959A

SUBLIMATION

SIZE RANGE: 2XS - 4XL

Steph is 182cm, 64kgs and wears a Small

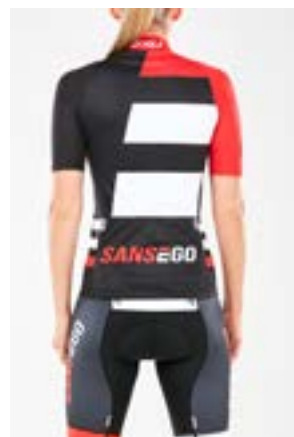
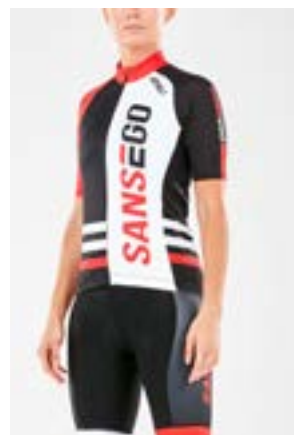

GARMENT FEATURES

01. ACF: Anatomical Cycle Fit
02. Reflective trims for visibility
03. Rear pockets for storage
04. Polygiene® antibacterial for lifetime odour elimination

FABRIC BENEFITS

01. HI FIL+
A performance fabric using high filament technology for maximum moisture management. Cross channelled yarns wick vapour from the inner to outer layers to keep the wearer dry and comfortable. Polygiene® antibacterial for lifetime odour elimination.
02. HI FIL VENT+
A high filament polyester yarn created into a cycle-specific vent knit structure to optimise ventilation and improve aerodynamics. Polygiene® antibacterial for lifetime odour elimination.

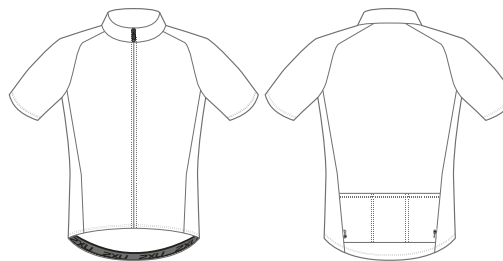

WOMEN'S SPRING CYCLE GILET

WX4967A

SUBLIMATION

SIZE RANGE: 2XS - 4XL

Steph is 182cm, 64kgs and wears a Small

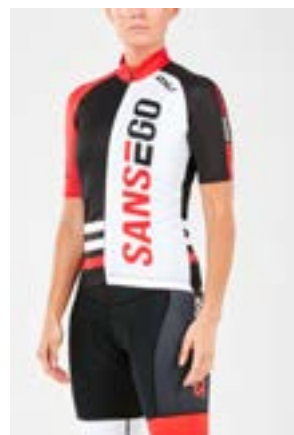

GARMENT FEATURES

01. ACF: Anatomical Cycle Fit
02. Reflective trims for visibility

FABRIC BENEFITS

01. VAPOR STRETCH
Lightweight stretch high gauge woven fabric that blocks out the wind while staying light and packable.
02. SENSOR MESH
Utilising a polyester-elastane breathable matrix for optimal air flow for the ultimate in moisture management.

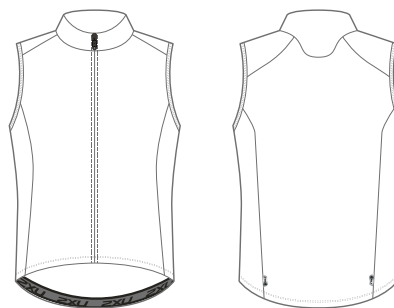

WOMEN'S WIND DEFENCE CYCLE GILET

WX4969A

SUBLIMATION

SIZE RANGE: 2XS - 4XL

Steph is 182cm, 64kgs and wears a Small

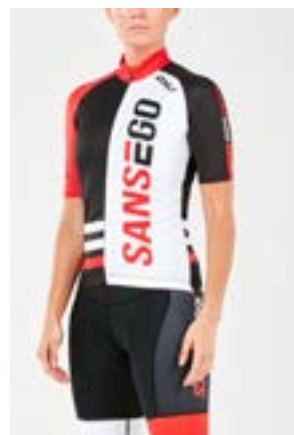

GARMENT FEATURES

01. ACF: Anatomical Cycle Fit
02. Reflective trims for visibility

FABRIC BENEFITS

01. 2X 20K STRETCH
Lightweight and flexible PU membrane that provides 20k waterproofing and 20k moisture vapour transfer. This fabric features a high filament jersey backing for comfort.
02. SENSOR MESH
Utilising a polyester-elastane breathable matrix for optimal air flow for the ultimate in moisture management.

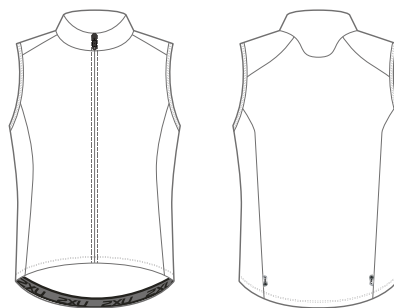

WOMEN'S THERMAL LONGSLEEVE CYCLE JACKET

WX4965A

SUBLIMATION

SIZE RANGE: 2XS - 4XL

Steph is 182cm, 64kgs and wears a Small

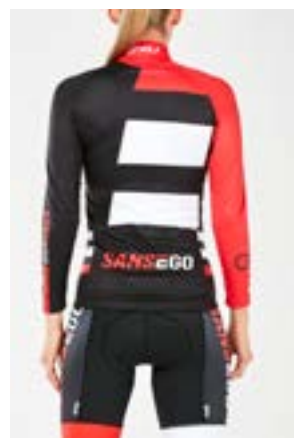

GARMENT FEATURES

01. ACF: Anatomical Cycle Fit
02. Reflective trims for visibility
03. Rear pockets for storage

FABRIC BENEFITS

01. VELO HEAT
Italian-made high filament brushed polyester to encourage the perfect microclimate. The high gauge knit provides dryness and warmth, while the brushed backing traps heat. The high filament x section yarns aid dryness.

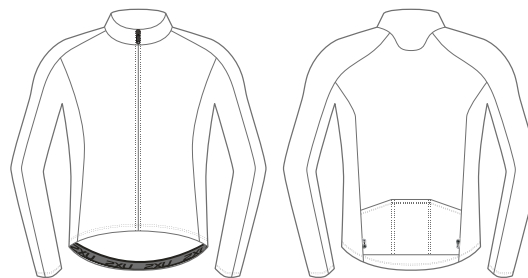

WOMEN'S WIND DEFENCE CYCLE JACKET

WX4971A

SUBLIMATION

SIZE RANGE: 2XS - 4XL

Steph is 182cm, 64kgs and wears a Small

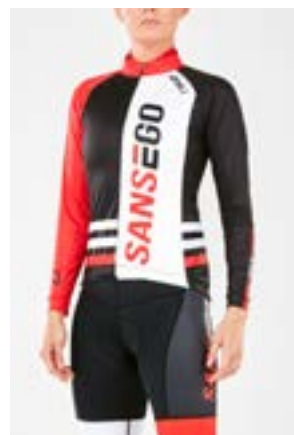

GARMENT FEATURES

01. ACF: Anatomical Cycle Fit
02. Reflective trims for visibility
03. Rear pockets for storage

FABRIC BENEFITS

01. 2X 20K STRETCH
Lightweight and flexible PU membrane that provides 20k waterproofing and 20k moisture vapour transfer. This fabric features a high filament jersey backing for comfort.

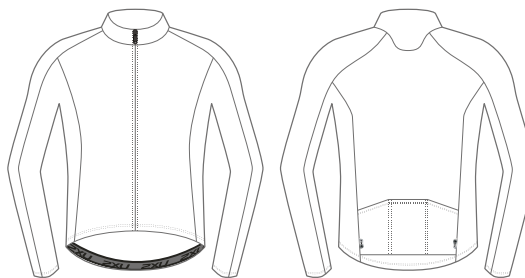



UNISEX

CUSTOM CYCLE COLLECTION ACCESSORIES

UNISEX CUSTOM CYCLE COLLECTION ACCESSORIES

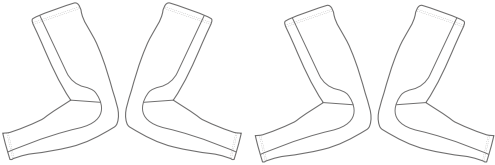

UX4976E
Unisex Cycle Arm Warmers

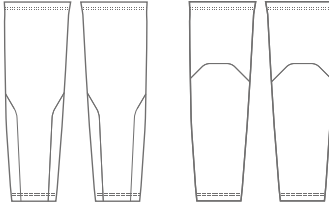

UX4977E
Unisex Cycle Leg Warmers

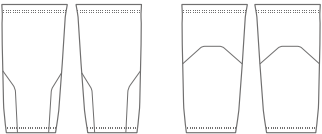

UX4978E
Unisex Cycle Knee Warmers

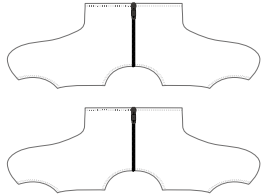

UX4979E
Unisex Cycle Booties

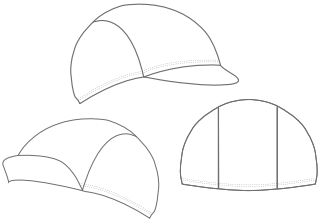

UX4982F
Unisex Cycle Cap

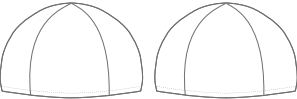

UX4981F
Unisex Cycle Beanie

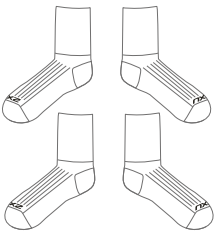

UX5444E
Unisex Sublimated Cycle Socks

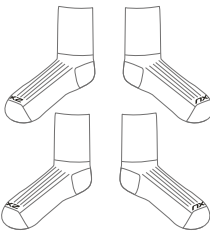

UX5481E
Unisex Knitted Cycle Socks

UNISEX CYCLE ARM WARMERS

UX4976A

SUBLIMATION

SIZE RANGE: 2XS-2XL



GARMENT FEATURES

01. ACF: Anatomical Cycle Fit

FABRIC BENEFITS

01. VELO PRO HEAT
High-filament yarn coupled with high density lycra yarn gives high power, durability and breathability. The brushed backing traps heat for warmth and increases moisture management.

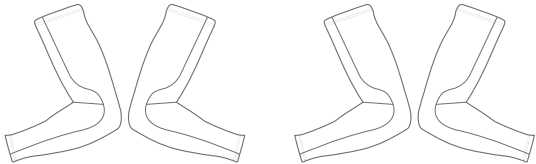

UNISEX CYCLE LEG WARMERS

UX4977B

SUBLIMATION

SIZE RANGE: 2XS-2XL



GARMENT FEATURES

- 01. ACF: Anatomical Cycle Fit

FABRIC BENEFITS

- 01. VELO PRO HEAT
High-filament yarn coupled with high density lycra yarn gives high power, durability and breathability. The brushed backing traps heat for warmth and increases moisture management.

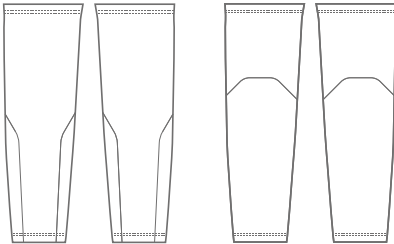

UNISEX CYCLE KNEE WARMERS

UX4978B

SUBLIMATION

SIZE RANGE: 2XS-2XL



GARMENT FEATURES

- 01. ACF: Anatomical Cycle Fit

FABRIC BENEFITS

- 01. VELO PRO HEAT
High-filament yarn coupled with high density lycra yarn gives high power, durability and breathability. The brushed backing traps heat for warmth and increases moisture management.

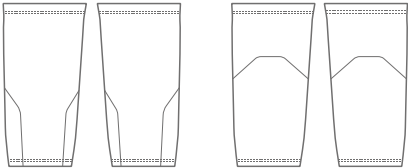

UNISEX CYCLE BOOTIES

UX4979E

SUBLIMATION

SIZE RANGE: S/M,L/XL,2XL/3XL



GARMENT FEATURES

01. Rear zipper for easy placement and removal

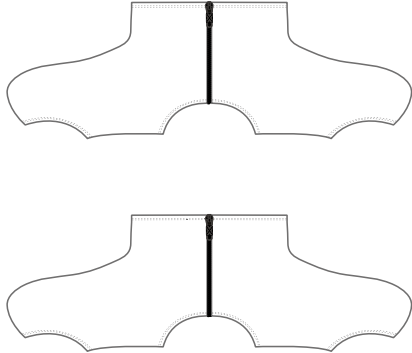

FABRIC BENEFITS

01. FLEX PRO
A polyester elastane blend to provide essential stretch and recovery.

UNISEX CYCLE CAP

UX4982F

SUBLIMATION

SIZE RANGE: S-XL



GARMENT FEATURES

- 01. Front peak to provide protection from the elements
- 02. Low profile to sit discreetly under a helmet

FABRIC BENEFITS

- 01. SMD
High-filament yarns in a mesh knit structure to ensure moisture control.

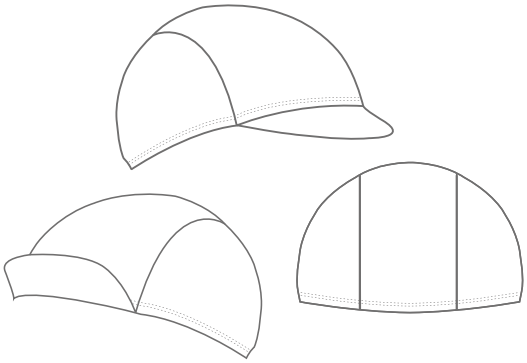

UNISEX CYCLE BEANIE

UX4981F

SUBLIMATION

SIZE RANGE: S-XL



GARMENT FEATURES

- 01. Low profile to sit discreetly under a helmet

FABRIC BENEFITS

- 01. HI FIL XTREME
High filament polyester yarns provides extreme moisture management and breathability, while the brushed inner delivers warmth and comfort.

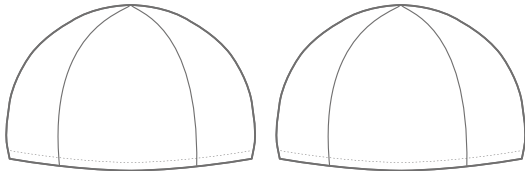

UNISEX SUBLIMATED CYCLE SOCKS

UX5444E

SUBLIMATION/ KNIT

SIZE RANGE: XS-XL



GARMENT FEATURES

01. Anatomical Left and Right foot design for comfort
02. Mild arch support
03. Engineered knit for articulated venting
04. BLK, NVY, RED foot moulds

FABRIC BENEFITS

01. Using high-filament nylon combined with high denier lycra to produce a firm fitting, durable and breathable fabric with excellent moisture management.

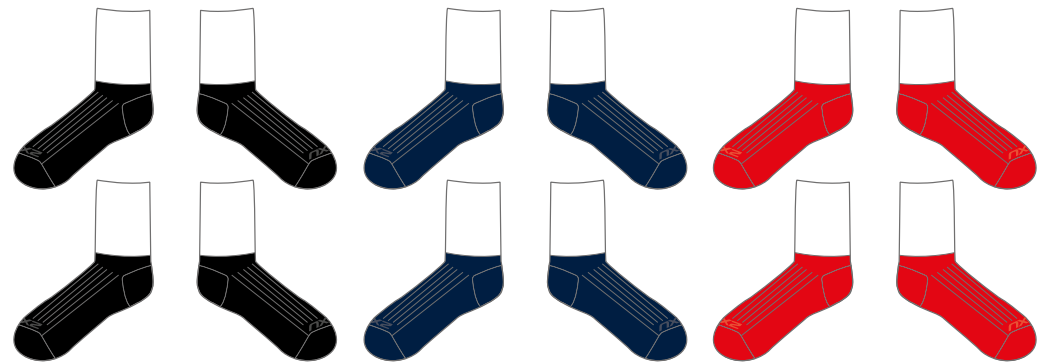

UNISEX KNITTED CYCLE SOCKS

UX5481E

KNIT

SIZE RANGE: XS-XL



GARMENT FEATURES

01. Anatomical Left and Right foot design for comfort
02. Mild arch support
03. Engineered knit for articulated venting
04. +200 available thread colours

FABRIC BENEFITS

01. Using high-filament nylon combined with high denier lycra to produce a firm fitting, durable and breathable fabric with excellent moisture management.

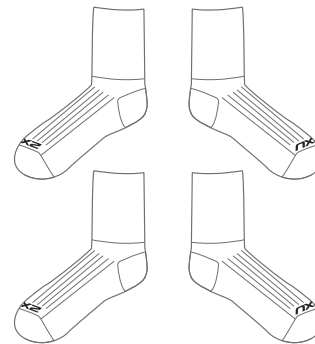





SIZE GUIDE

CUSTOM CYCLE COLLECTION

CUSTOM CYCLE COLLECTION SIZING INFORMATION - MEN'S

MEN'S SIZING

MEASUREMENT (circumference)		XS	S	M	L	XL	2XL	3XL	4XL
Chest	cm	87-91	92-96	97-101	102-106	107-111	112-116	117-121	122-126
	inches	34 ¹ / ₄ -35 ⁷ / ₈	36 ¹ / ₄ -35 ³ / ₄	38 ¹ / ₈ -39 ³ / ₄	40 ¹ / ₈ -41 ³ / ₄	42 ¹ / ₈ -43 ³ / ₄	44 ¹ / ₈ -45 ⁵ / ₈	46 ¹ / ₈ -47 ⁵ / ₈	48-49 ⁵ / ₈
Waist	cm	70-74	75-79	80-84	85-89	90-94	95-99	100-104	105-109
	inches	27 ¹ / ₂ -29 ¹ / ₈	29 ¹ / ₂ -31 ¹ / ₈	31 ¹ / ₂ -33	33 ¹ / ₂ -35	35 ¹ / ₈ -37	37 ³ / ₈ -39	39 ³ / ₈ -41	41 ³ / ₈ -42 ⁷ / ₈

UNISEX SOCK SIZING

	XS	S	M	L	XL
US	>4	4-6.5	7-9.5	10-13	<13
EU	>34	34-37	38-41	42-46	<46

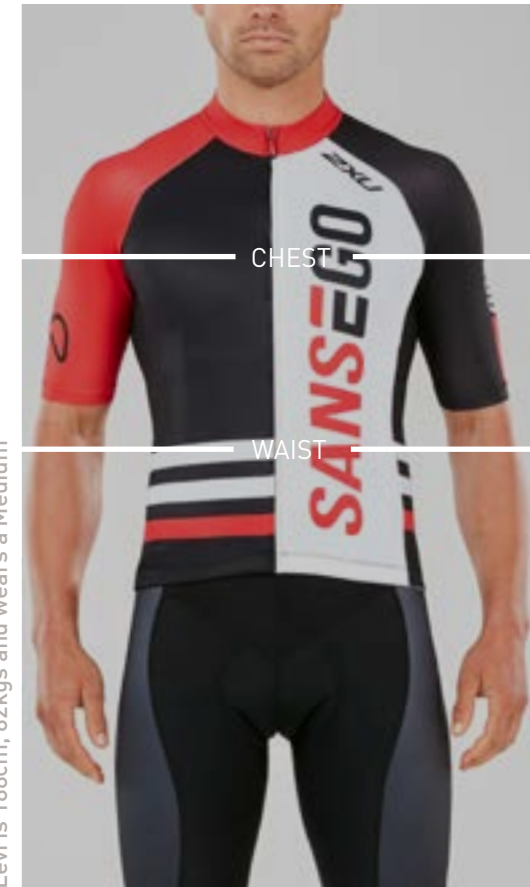

Levi is 188cm, 82kgs and wears a Medium

CUSTOM CYCLE COLLECTION SIZING INFORMATION - WOMEN'S

WOMEN'S SIZING

MEASUREMENT (circumference)		2XS	XS	S	M	L	XL	2XL	3XL
Bust	cm	78-82	83-87	88-92	93 - 97	98 -102	103-107	108-112	113-117
	inches	30 ³ / ₄ -32 ¹ / ₄	32 ⁵ / ₈ -34 ¹ / ₄	34 ⁵ / ₄ -36 ¹ / ₄	36 ⁵ / ₈ -38 ¹ / ₄	38 ⁵ / ₈ -40 ¹ / ₄	40 ¹ / ₂ -42 ¹ / ₈	42 ¹ / ₂ -44 ¹ / ₈	44 ¹ / ₂ -46
Waist	cm	58-62	63-67	68-72	73-77	78-82	83-87	88-92	93-97
	inches	22 ³ / ₈ -24 ³ / ₈	24 ³ / ₄ -26 ³ / ₈	26 ³ / ₄ -28 ³ / ₈	28 ³ / ₄ -30 ³ / ₈	30 ³ / ₄ -32 ¹ / ₄	32 ³ / ₄ -34 ¹ / ₄	34 ⁵ / ₈ -36 ¹ / ₄	36 ⁵ / ₈ -38 ¹ / ₄
Hip	cm	86-90	91-95	96-100	101-105	106-110	111-115	116-120	121-125
	inches	33 ⁷ / ₈ -35 ¹ / ₂	35 ⁷ / ₈ -37 ³ / ₈	37 ³ / ₄ -39 ³ / ₈	39 ³ / ₄ -41 ³ / ₈	41 ³ / ₄ -43 ³ / ₈	43 ³ / ₄ -54 ¹ / ₄	45 ⁵ / ₈ -47 ¹ / ₄	47 ⁵ / ₈ -49 ¹ / ₄



Steph is 182cm, 64kgs and wears a Small

NOW YOU CAN
CUSTOMISE
THE WORLD'S MOST ADVANCED
COMPRESSION
TECHNOLOGY



- 7 FABRIC COLOURS
- 15 STITCH COLOURS
- 15 PRINT COLOURS
- 2 WAISTBAND OPTIONS
- 3,150 CUSTOMISABLE SCENARIOS

THE 2XU STORY

To those who compete to win: 2XU compression can be the difference between victory or defeat.
To those who compete against themselves: 2XU compression is the means to a personal best.
To those who compete against the pressure of modern life: 2XU compression is fitness made possible.

2XU (pronounced Two Times You) has grown to become one of the most technical sporting apparel brands in the world; driven by a relentless obsession to advance human performance through the development of world-leading performance-enhancing compression garments.

2XU is at the forefront of global sports compression wear and is a market leader in converting scientific, independent, evidenced based research into the world's best performance enhancing sportswear. Starting out as a triathlon specific sportswear brand in 2005, the past decade has seen our range of apparel and accessories grow, together with the advancement of our world-leading performance-enhancing compression garments.

Elite athletes rely on 2XU every day and we're proud to be the official compression partner of the Australian Institute of Sport, the National Strength and Conditioning Association and numerous other national and state sports governing bodies. Together with world renowned tertiary institution, RMIT University, 2XU utilises elite athletes and sports science experts in conjunction with the world's leading fabric testing technology to validate the performance advantage of our garments.

Now present in 71 countries around the world, 2XU has graced the bodies of multiple world champion athletes and has formed powerful alliances and partnerships across organisations and sports world-wide including basketball, rugby, football, baseball, hockey, swimming, netball, soccer, triathlon, cycling, and running.

Our garments take athletes beyond what they thought possible and enable them to train smarter, recover faster and perform better.



COMPRESSION BENEFITS

Since 2005, 2XU has been developing the world's most advanced compression technology, which support athletes prepare, perform and recover better.



PREPARATION

Proper warm up is important to prepare for training and competition. 2XU's graduated compression garments promote increased blood flow for faster warm up and greater oxygen to muscle tissue. This allows muscles to move more efficiently.

PERFORMANCE

Protect muscles to help reduce damage, fatigue and long term overuse injuries for a stronger performance. 2XU compression helps to align and keep muscles in place to reduce muscle oscillation that can lead to muscle strain and soreness.

RECOVERY

Restore your body back to peak levels in the fastest possible time. 2XU graduated compression increases venous return to the heart and increases blood circulation. This helps with the removal of blood lactate from muscles to reduce swelling and speed up muscle repair for faster recovery.

COMPRESSION FABRIC TECH INFO

Custom compression range uses two main fabric types to ensure optimal compression for each body part.

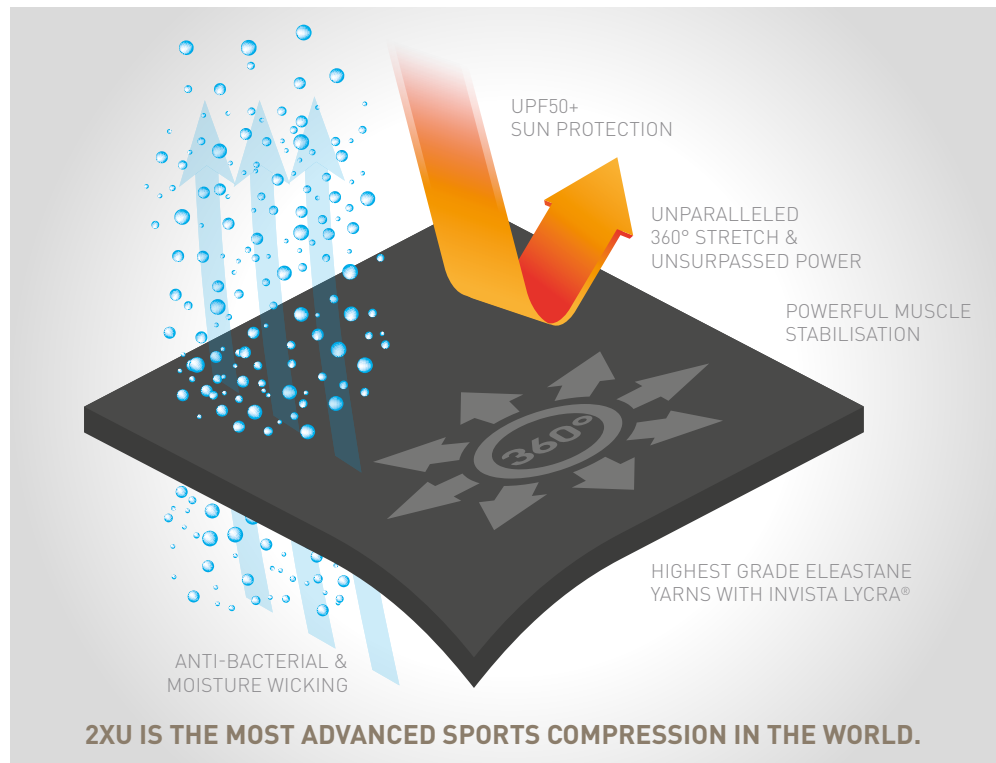

As a premium global sportswear brand, 2XU's point of difference is a unique fabric combination that is light, flexible, powerful and durable; delivering physiological benefits far beyond the competition.

Further fabric benefits include:

- > Superior grade circular knit structure to deliver multi-directional stretch, greater flexibility, power and durability
- > Highest grade elastane yarns with invistra lycra® for durability
- > Anti-bacterial and anti-odour properties to reduce stink
- > Moisture-wicking fabric to keep the wearer dry
- > Flatlock seams to reduced chafing
- > UPF50+ for maximum sun protection



UNIQUE FABRIC
COMBINATION



HIGHEST LEVEL
CIRCULAR KNIT



GRADUATED
COMPRESSION



MEN'S

CUSTOM COMPRESSION RANGE

MENS COMPRESSION RANGE OVERVIEW

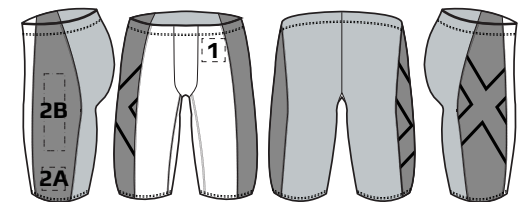
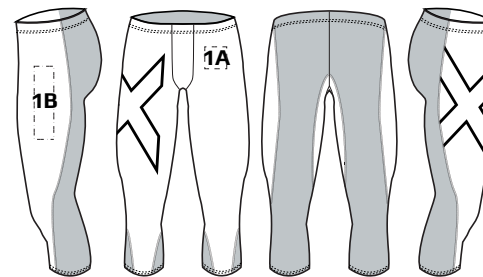
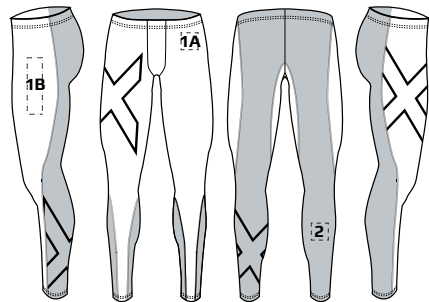

TR2 LOWER BODY RANGE

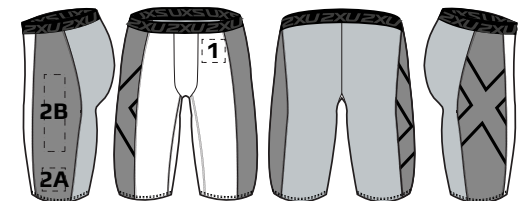
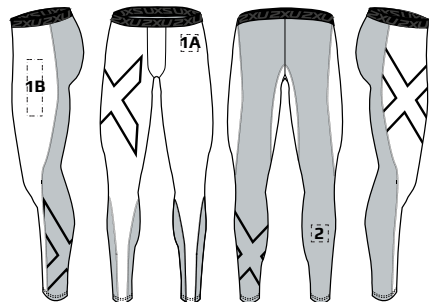

ACCELERATE LOWER BODY RANGE

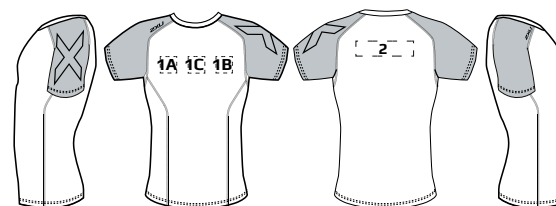
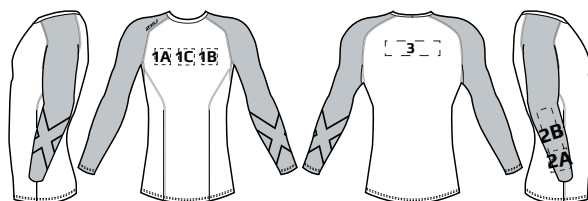

UPPER BODY COMPRESSION RANGE

TR2 COMPRESSION

MAX4750b

MEN'S TR2 CUSTOM COMPRESSION TIGHTS
(SIZE RANGE: XXS - XXL, ST, MT, LT, XLT, XXLT)



GARMENT FEATURES

01. Compression support to adductor, glute, quad, hamstring and calf muscles to reduce muscle damage
02. Graduated compression for greater recovery between workouts
03. PWX 70D front and 105D back panels
04. Drawstring waistband for secure fit
05. Flatlock seams to reduce chafing

COMPRESSION BENEFITS

- Reduced muscle fatigue and soreness
- Reduced muscle damage and risk of overuse injuries
- Improved performance
- Improved muscle alignment
- Increased agility
- Faster recovery

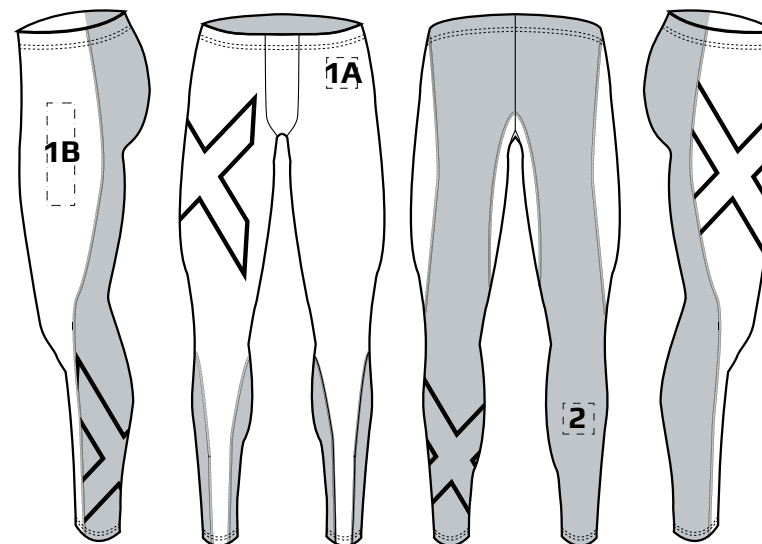

TR2 COMPRESSION

MAX4751b

MEN'S TR2 CUSTOM COMPRESSION 3/4 TIGHTS
(SIZE RANGE: XXS - XXL, ST, MT, LT, XLT, XXL)



GARMENT FEATURES

01. Compression support to adductor, glute, quad, hamstring and calf muscles to reduce muscle damage
02. PWX 70D front and 105D back panels
03. Drawstring waistband for secure fit
04. Flatlock seams to reduce chafing

COMPRESSION BENEFITS

- Reduced muscle fatigue and soreness
- Reduced muscle damage and risk of overuse injuries
- Improved performance
- Improved muscle alignment
- Increased agility



TR2 COMPRESSION

MAX4752b

MEN'S TR2 CUSTOM COMPRESSION SHORTS

(SIZE RANGE: XXS - XXXL)



GARMENT FEATURES

01. Compression support to adductor, glute, quad, hamstring and calf muscles to reduce muscle damage
02. PWX 70D front and 105D back panels
03. Drawstring waistband for secure fit
04. Flatlock seams to reduce chafing

COMPRESSION BENEFITS

- Reduced muscle fatigue and soreness
- Reduced muscle damage and risk of overuse injuries
- Improved performance
- Improved muscle alignment
- Increased agility

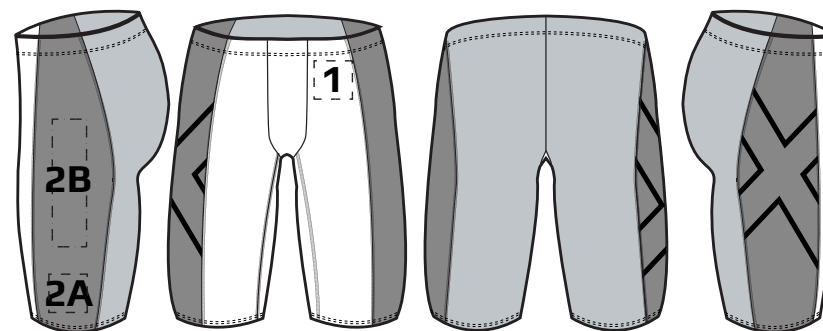

ACCELERATE COMPRESSION

MAX4654b

MEN'S ACCELERATE CUSTOM COMPRESSION TIGHTS
(SIZE RANGE: XXS - XXL, ST, MT, LT, XLT, XXLT)



GARMENT FEATURES

01. Compression support to adductor, glute, quad and hamstring muscles to reduce muscle vibration
02. PWX 70D front and 105D back panels
03. 2XU jacquard waistband for comfort
04. Flatlock seams to reduce chafing

COMPRESSION BENEFITS

- Reduced muscle fatigue and soreness
- Reduced muscle damage and risk of overuse injuries
- Improved performance
- Improved muscle alignment
- Increased agility

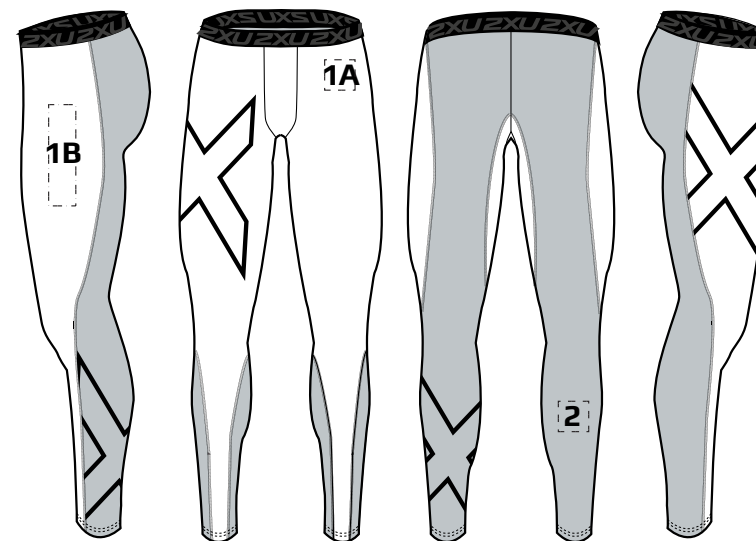

ACCELERATE COMPRESSION

MAX4655b

MEN'S ACCELERATE CUSTOM COMPRESSION 3/4 TIGHTS
(SIZE RANGE: XXS - XXL, ST, MT, LT, XLT, XXLT)



GARMENT FEATURES

01. Compression support to adductor, glute, quad and hamstring muscles to reduce muscle vibration
02. PWX 70D front and 105D back panels
03. 2XU jacquard waistband for comfort
04. Flatlock seams to reduce chafing

COMPRESSION BENEFITS

- Reduced muscle fatigue and soreness
- Reduced muscle damage and risk of overuse injuries
- Improved performance
- Improved muscle alignment
- Increased agility



ACCELERATE COMPRESSION

MAX4656b

MEN'S ACCELERATE CUSTOM COMPRESSION SHORTS

(SIZE RANGE: XXS - XXXL)



GARMENT FEATURES

01. Compression support to adductor, glute, quad and hamstring muscles to reduce muscle vibration
02. PWX 70D front and 105D back panels
03. 2XU jacquard waistband for comfort
04. Flatlock seams to reduce chafing

COMPRESSION BENEFITS

- Reduced muscle fatigue and soreness
- Reduced muscle damage and risk of overuse injuries
- Improved performance
- Improved muscle alignment
- Increased agility

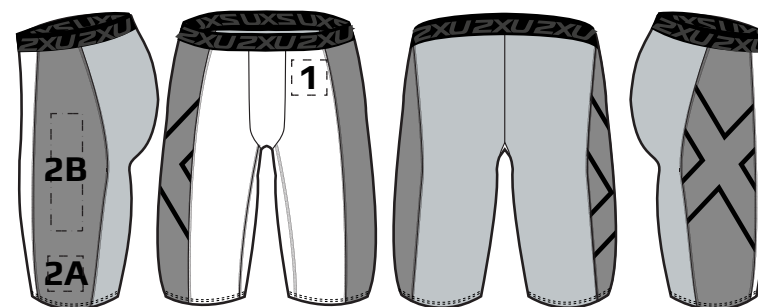

UPPER BODY COMPRESSION

MAX4657a

MEN'S CUSTOM COMPRESSION LONG SLEEVE TOP
(SIZE RANGE: XS - XXXL)



GARMENT FEATURES

01. PWX 70D fabric supports biceps, triceps, forearm, deltoids and core stomach muscles
02. Graduated compression increases blood circulation for improved recovery and reduce muscle stiffness post exercise
03. Powermesh panels for greater breathability in key regions
04. Raglan sleeve construction for unrestricted movement
05. Flatlock seams to reduce chafing

COMPRESSION BENEFITS

- Reduced muscle fatigue and soreness
- Reduced muscle damage and risk of overuse injuries
- Improved performance
- Improved muscle alignment
- Increased agility

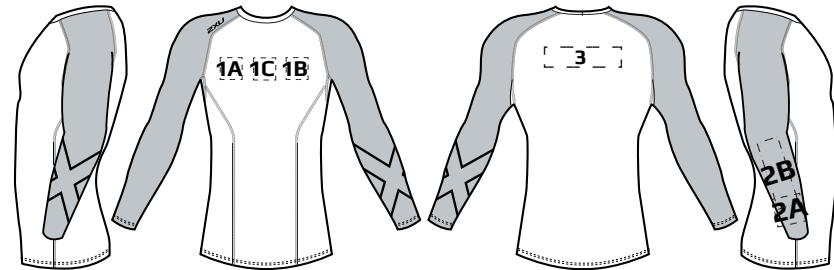

UPPER BODY COMPRESSION

MAX4658a

MEN'S CUSTOM COMPRESSION SHORT SLEEVE TOP
(SIZE RANGE: XS - XXXL)



GARMENT FEATURES

01. PWX 70D fabric supports biceps, triceps, deltoids and core stomach muscles for greater postural awareness and pull shoulders back
02. Powermesh panels for greater breathability in key regions
03. Raglan sleeve construction for unrestricted movement
04. Flatlock seams to reduce chafing

COMPRESSION BENEFITS

- Reduced muscle fatigue and soreness
- Reduced muscle damage and risk of overuse injuries
- Improved performance
- Improved muscle alignment
- Increased agility

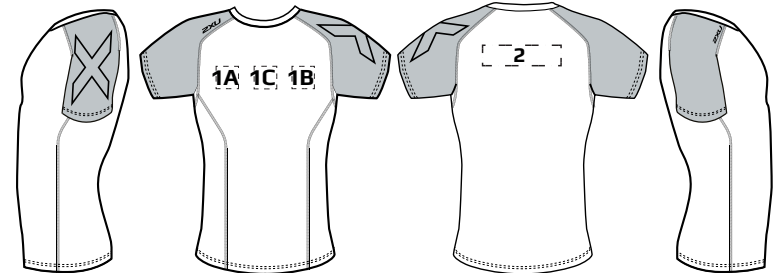

UPPER BODY COMPRESSION

MAX4659a

MEN'S CUSTOM COMPRESSION SLEEVELESS TOP

(SIZE RANGE: XS - XXXL)



GARMENT FEATURES

01. PWX 70D fabric supports upper body and core stomach muscles for postural awareness
02. Powermesh panels for greater breathability in key regions
03. Sleeveless construction for unrestricted movement
04. Flatlock seams to reduce chafing

COMPRESSION BENEFITS

- Reduced muscle fatigue and soreness
- Reduced muscle damage and risk of overuse injuries
- Improved performance
- Improved muscle alignment
- Increased agility



WOMEN'S

CUSTOM COMPRESSION RANGE



WOMENS COMPRESSION RANGE OVERVIEW

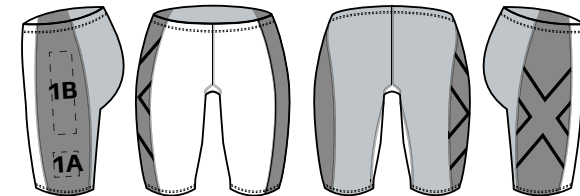
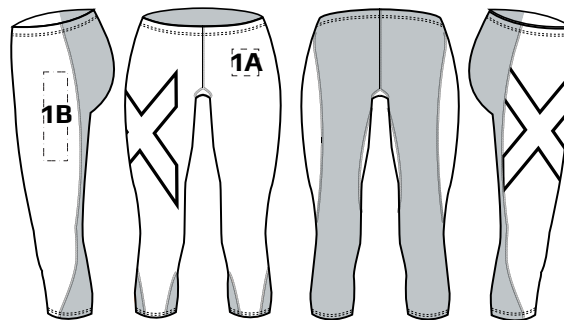
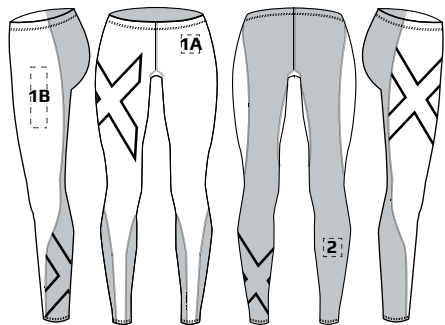

TR2 LOWER BODY RANGE

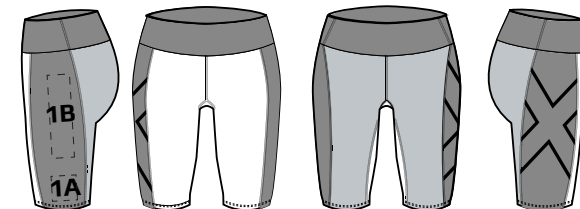
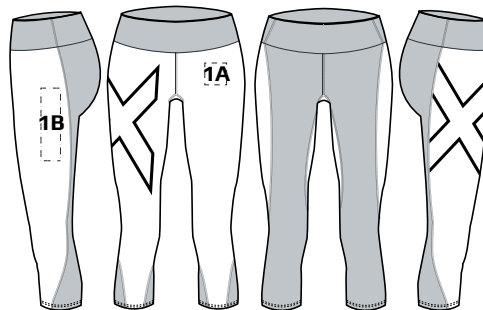
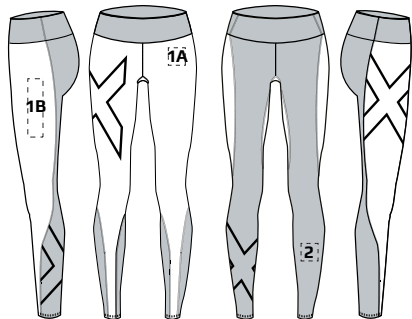

MID-RISE LOWER BODY RANGE

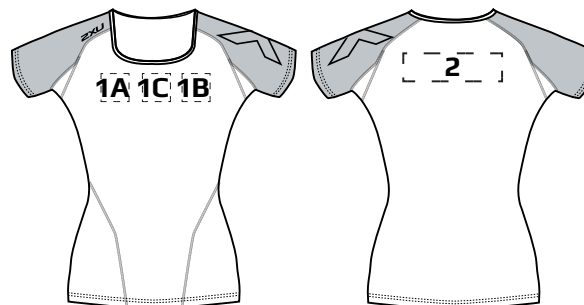

UPPER BODY COMPRESSION RANGE

TR2 COMPRESSION

WAX4756b

WOMEN'S TR2 CUSTOM COMPRESSION TIGHTS
(SIZE RANGE: XXS - XXL, XST, ST, MT, LT)



GARMENT FEATURES

01. Compression support to adductor, glute, quad, hamstring and calf muscles to reduce muscle vibration
02. PWX 70D front and 105D back panels for flexibility and power
03. Graduated compression for greater recovery between workouts
04. Drawstring waistband for secure fit
05. Flatlock seams to reduce chafing

COMPRESSION BENEFITS

- Reduced muscle fatigue and soreness
- Reduced muscle damage and risk of overuse injuries
- Improved performance
- Improved muscle alignment
- Increased agility
- Faster recovery

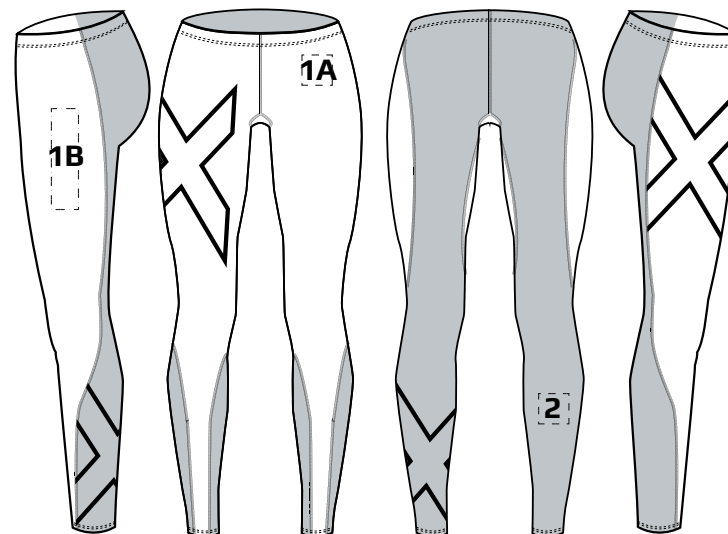

TR2 COMPRESSION

WAX4757b

WOMEN'S TR2 CUSTOM COMPRESSION 3/4 TIGHTS
(SIZE RANGE: XXS - XXL, XST, ST, MT, LT)



GARMENT FEATURES

01. Compression support to adductor, glute, quad, hamstring and calf muscles
02. PWX 70D front and 105D back panels for flexibility and power
03. Drawstring waistband for secure fit
04. Flatlock seams to reduce chafing

COMPRESSION BENEFITS

- Reduced muscle fatigue and soreness
- Reduced muscle damage and risk of overuse injuries
- Improved performance
- Improved muscle alignment
- Increased agility

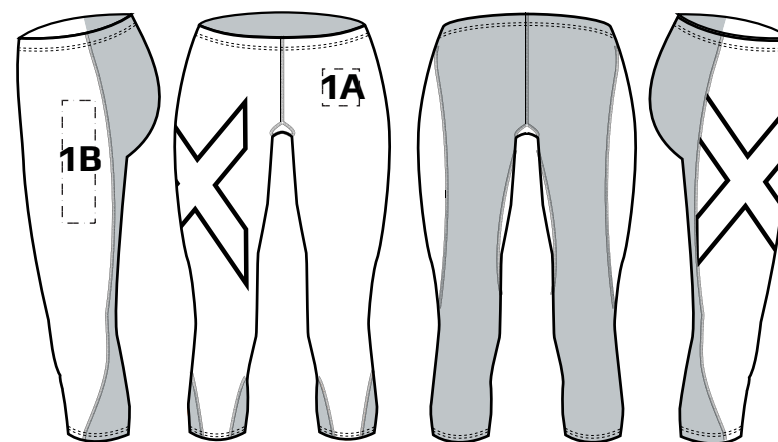

TR2 COMPRESSION

WAX4758b

WOMEN'S TR2 CUSTOM COMPRESSION SHORTS
(SIZE RANGE: XXS - XXL)



GARMENT FEATURES

01. Compression support to adductor, glute, quad and hamstring muscles to reduce muscle vibration
02. PWX 70D front and 105D back panels for flexibility and power
03. Drawstring waistband for secure fit
04. Flatlock seams to reduce chafing

COMPRESSION BENEFITS

- Reduced muscle fatigue and soreness
- Reduced muscle damage and risk of overuse injuries
- Improved performance
- Improved muscle alignment
- Increased agility

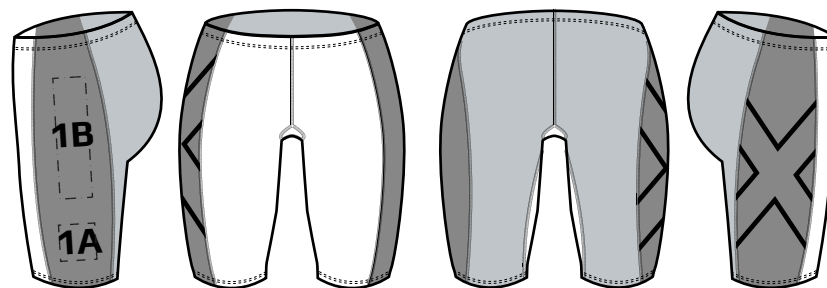

MID-RISE COMPRESSION

WAX4753b

WOMEN'S MID-RISE CUSTOM COMPRESSION TIGHTS

(SIZE RANGE: XXS - XXL, XST, ST, MT, LT)



GARMENT FEATURES

01. Compression support for greater protection to abductor, glute, quad, hamstring and calf muscles
02. Graduated compression for improved warmup and faster recovery post exercise
03. PWX 70D front and 105D back panels for flexibility and power
04. Power comfort wide waistband
05. Body firming and sculpting fit
06. Flatlock comfort seams to reduce chafe

COMPRESSION BENEFITS

- Reduced muscle fatigue and soreness
- Reduced muscle damage and risk of overuse injuries
- Improved performance
- Improved muscle alignment
- Increased agility
- Faster recovery

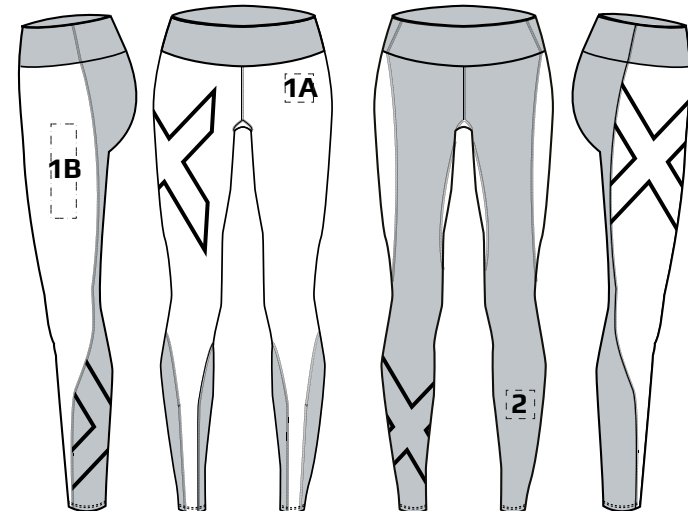

MID-RISE COMPRESSION

WAX4754b

WOMEN'S MID-RISE CUSTOM COMPRESSION 3/4 TIGHTS
(SIZE RANGE: XXS - XXL, XST, ST, MT, LT)



GARMENT FEATURES

01. Compression support for greater protection to abductor, glute, quad, hamstring and calf muscles to reduce muscle vibration
02. PWX 70D front and 105D back panels for flexibility and power
03. Power comfort wide waistband
04. Bodyfirming and sculpting fit
05. Flatlock comfort seams to reduce chafe

COMPRESSION BENEFITS

- Reduced muscle fatigue and soreness
- Reduced muscle damage and risk of overuse injuries
- Improved performance
- Improved muscle alignment
- Increased agility

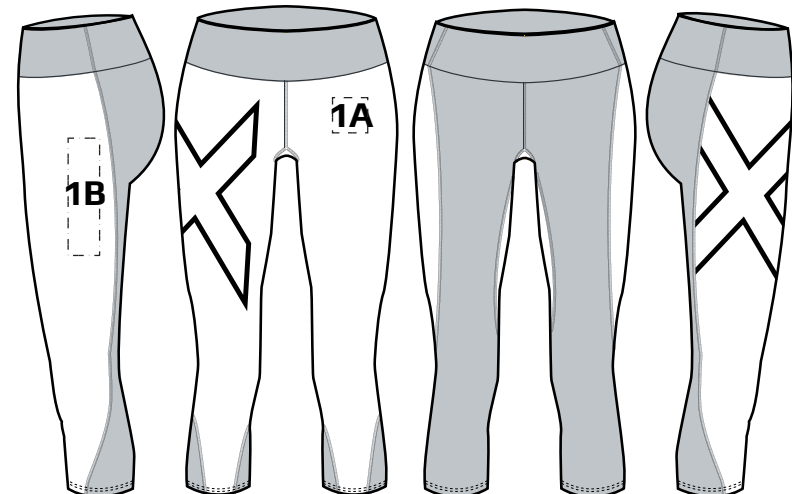

MID-RISE COMPRESSION

WAX4755b

WOMEN'S MID-RISE CUSTOM COMPRESSION SHORTS

(SIZE RANGE: XXS - XXL)

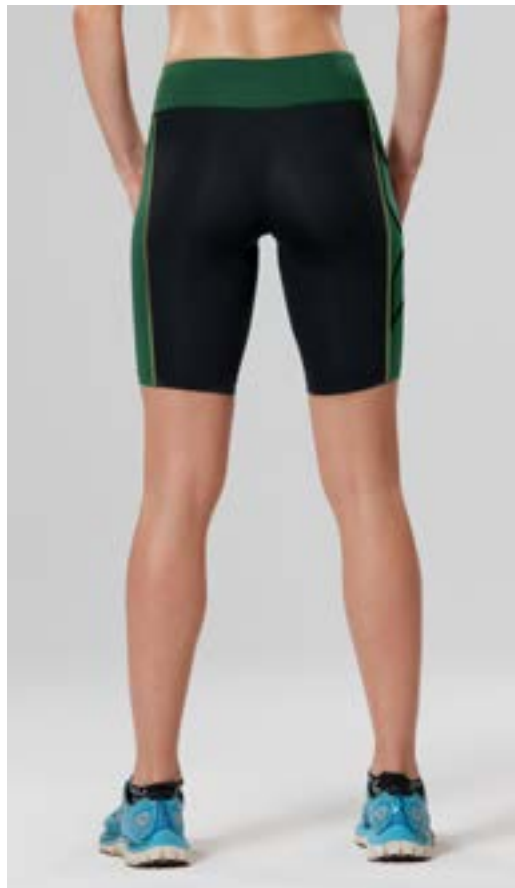

GARMENT FEATURES

01. Compression support to abductor, glute, quad and hamstring muscles to reduce muscle vibration
02. PWX 70D front and 105D back panels for flexibility and power
03. Power comfort wide waistband
04. Body firming and sculpting fit
05. Flatlock seams to reduce chafing

COMPRESSION BENEFITS

- Reduced muscle fatigue and soreness
- Reduced muscle damage and risk of overuse injuries
- Improved performance
- Improved muscle alignment
- Increased agility

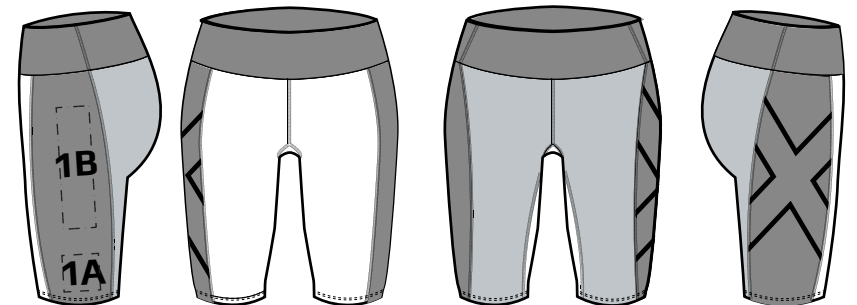

UPPER BODY COMPRESSION

WAX4759a

WOMEN'S CUSTOM COMPRESSION LONG-SLEEVE TOP
(SIZE RANGE: XS - XL)



GARMENT FEATURES

- 01. PWX 70D fabric supports biceps, triceps, forearm, deltoids and core stomach muscles
- 02. Graduated compression increases blood circulation for improved recovery and reduce muscle stiffness post exercise
- 03. Powermesh panels for greater breathability in key regions
- 04. Raglan sleeve construction for unrestricted movement
- 05. Flatlock seams to reduce chafing

COMPRESSION BENEFITS

- Reduced muscle fatigue and soreness
- Reduced muscle damage and risk of overuse injuries
- Improved performance
- Improved muscle alignment
- Increased agility

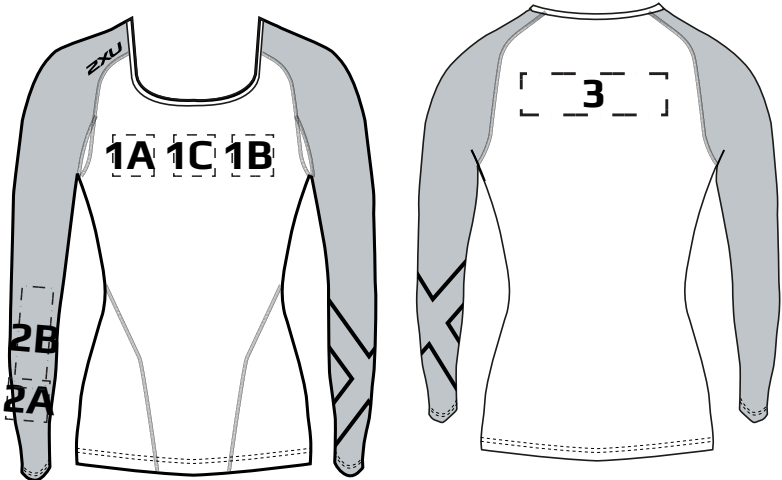

UPPER BODY COMPRESSION

WAX4814a

WOMEN'S CUSTOM COMPRESSION SHORT-SLEEVE TOP
(SIZE RANGE: XS - XL)

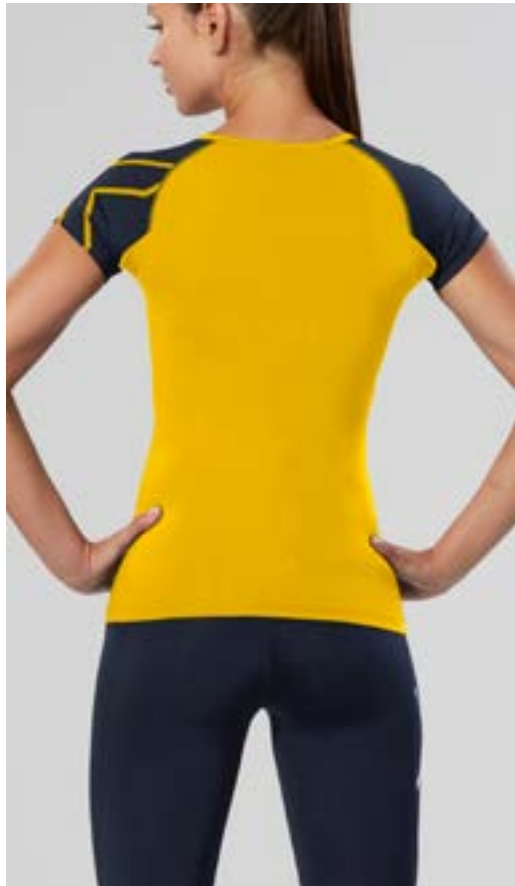

GARMENT FEATURES

01. PWX 70D fabric supports biceps, triceps, deltoids and core stomach muscles for greater postural awareness and pull shoulders back
02. Powermesh panels for greater breathability in key regions
03. Raglan sleeve construction for unrestricted movement
04. Flatlock seams to reduce chafing

COMPRESSION BENEFITS

- Reduced muscle fatigue and soreness
- Reduced muscle damage and risk of overuse injuries
- Improved performance
- Improved muscle alignment
- Increased agility

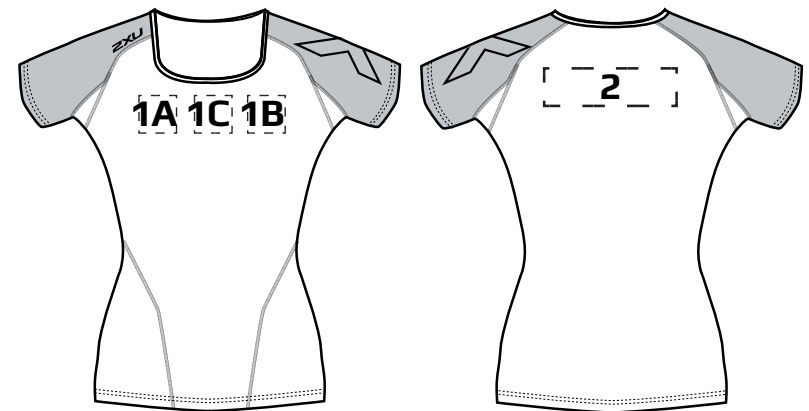



UNISEX

CUSTOM COMPRESSION ACCESSORIES

UNISEX COMPRESSION

UAX4660a

UNISEX CUSTOM COMPRESSION ARM GUARDS / SOLD IN PAIRS
(SIZE RANGE: XS - XXL)



GARMENT FEATURES

- 01. Compression support to the forearm, elbow and bicep to reduce muscle vibration
- 02. Graduated fit to promote faster warm-up of muscles
- 03. Flatlock seams to reduce chafing

COMPRESSION BENEFITS

- Reduced muscle fatigue and soreness
- Reduced muscle damage and risk of overuse injuries
- Improved performance
- Improved muscle alignment

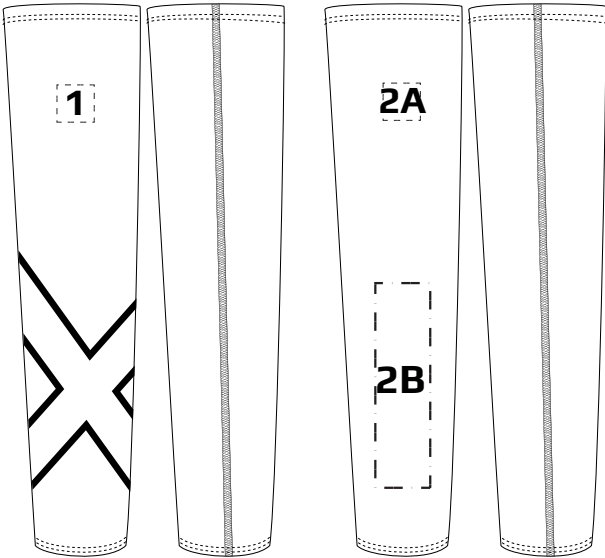

UNISEX COMPRESSION

UAX4760b

UNISEX CUSTOM COMPRESSION CALF GUARDS / SOLD IN PAIRS
(SIZE RANGE: XXS - XXL)



GARMENT FEATURES

01. Compression support for greater protection to calf and shin muscles to reduce muscle fatigue
02. Lightweight to wear on its own or under socks or other apparel
03. Flatlock comfort seams to reduce chafe

COMPRESSION BENEFITS

- Reduced muscle fatigue and soreness
- Reduced muscle damage and risk of overuse injuries
- Improved performance
- Improved muscle alignment
- Increased agility

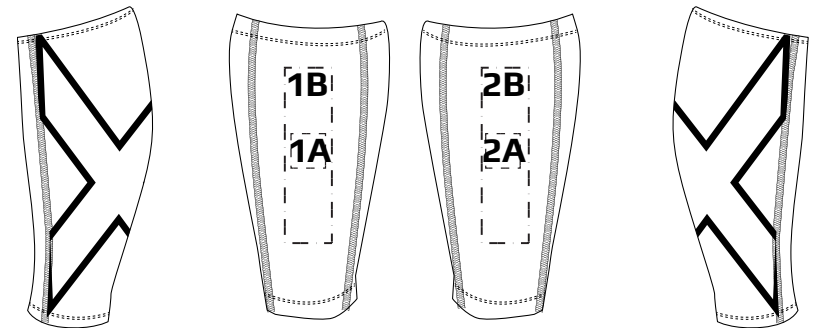

CUSTOM COMPRESSION

FABRIC COLOURS

FABRIC COLOURS

Choose from these seven fabric colours to create customised compression garments, which best represent your team.

BLACK



WHITE

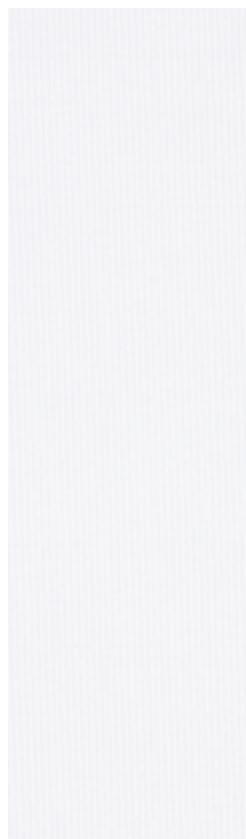

ROYAL | Reflex Blue C



RED | 200C



GOLD | 1235C



NAVY | 282C



FORREST | 343C



2XU BRANDING

COLOURS

BRANDING PRINT COLOURS

Customise your compression garments further by selecting one of 15 available screen print colours for the 2XU and the 'X'-device' branding.

BLACK



WHITE



COOL GREY | 9C



RED | 200C



MAROON | 209C



PINK | 205C



PURPLE | 268C



ORANGE | 021C



SKY | 298C



ROYAL | Reflex Blue C



NAVY | 282C



FORREST | 343C



LIME | 375C



SUN | 116C



GOLD | 1235C



STITCHING

COLOURS

STITCHING COLOURS

Add a point of difference to your design by selecting one of 15 available colours for your flatlock stitching.



NAVY | 282C

SKY | 298C

FORREST | 343C

LIME | 375C

SUN | 116C

GOLD | 1235C

ORANGE | 021C



BLACK

WHITE

COOL GREY | 9C

RED | 200C

MAROON | 209C

PINK | 205C

PURPLE | 268C

ROYAL | Reflex Blue C

CUSTOMER LOGO

APPLICATION

CLIENT LOGO(S) APPLICATION

The final step for your custom compression is adding your team logo(s) and/ or text. Please follow the placements and logo size guidelines and ensure a maximum of three Pantone colours per logo, and no gradients.



LOGO EXAMPLES



Side leg logo (position 1B)

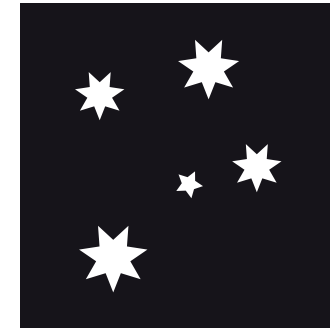

Calf logo (position 2)

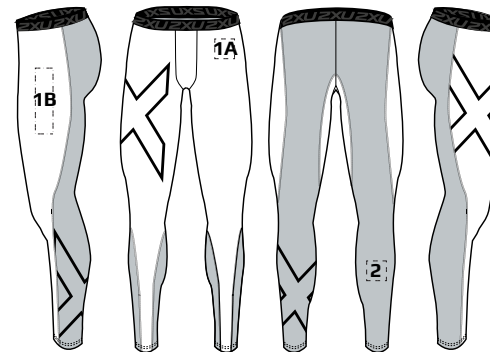



LOGO EXAMPLES



Chest logo (position 1B).



Back logo (position3).

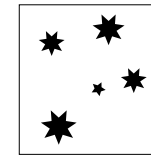

Sleeve logo (position 2A).

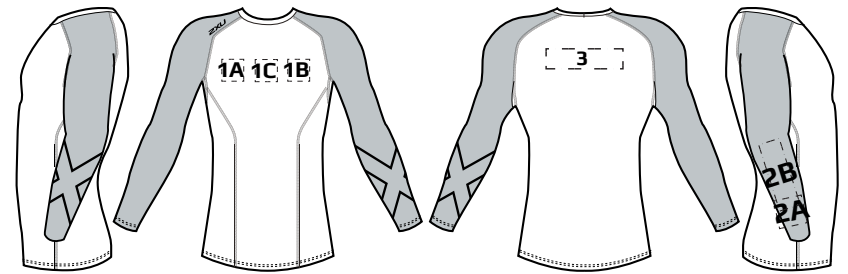

WOMEN'S COMPRESSION SIZING

TIGHTS & 3/4 TIGHTS

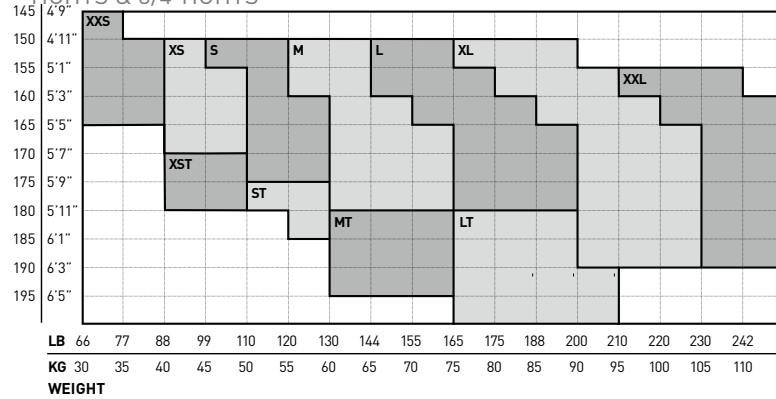

SHORTS

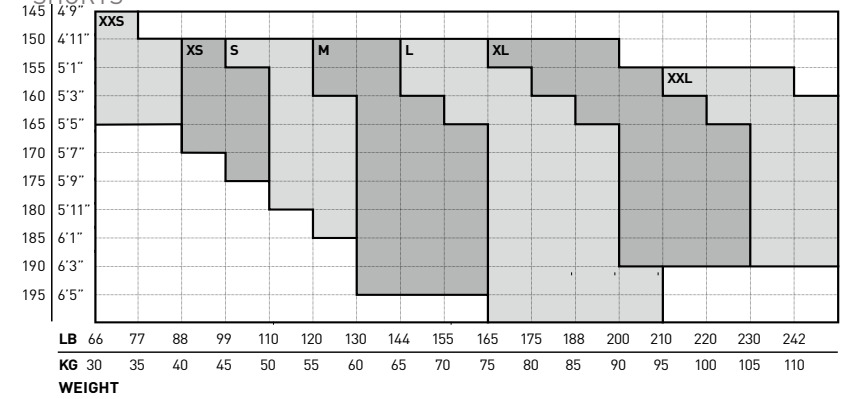

TOPS

	XS	S	M	L	XL									
CM	74	76	79	81	84	86	89	91	94	96	99	102	104	107
IN	29"	30"	31"	32"	33"	34"	35"	36"	37"	38"	39"	40"	41"	42"

CHEST

ARM SLEEVES

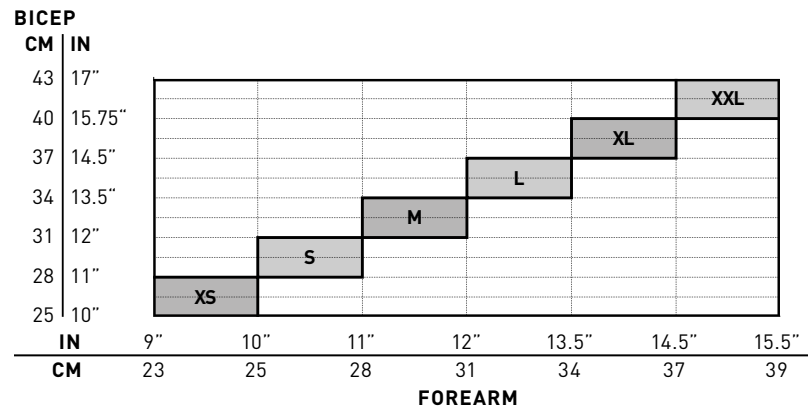

CALF GUARDS

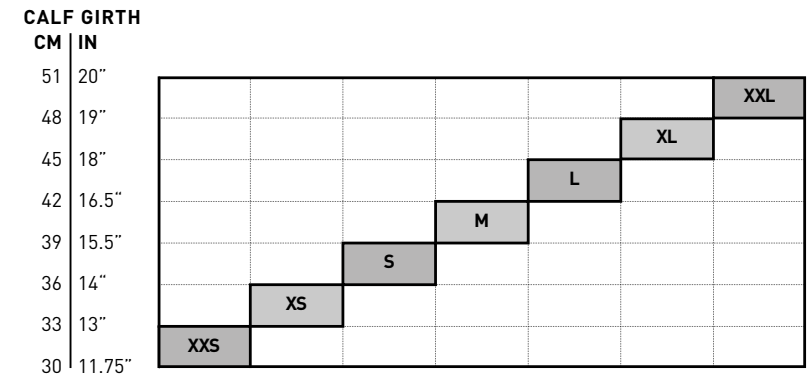

BSR RANGE



2XU
C U S T O M

2XU
C U S T O M

BSR FABRIC TECHNICAL INFORMATION

The BSR range uses high-end fabric types to ensure optimal fit for each body part. As a premium global sportswear brand, 2XU's point of difference is a unique fabric combination that is light, flexible, powerful and durable; delivering physiological benefits far beyond the competition.

3D THERMAL

A 3D knit structure of this mesh fabric comes finished with a brushed underside to offer a seriously warm, bulk-free solution. High-filament polyester yarns deliver extreme moisture management and optimal thermoregulation.

HI^FIL +

Utilising high filament technology, 2XU has engineered a performance fabric to maximise moisture management. Cross-channeled yarns wick vapour from the inner to outer layers to keep the wearer as dry and comfortable as possible, while a mesh structure promises breathability. Hi FIL+ includes Polygiene ® odour control technology ensuring you stay fresh and odour free. Wear more, wash less and reduce your environmental footprint.

HI^FIL STRETCH

Utilising high-filament technology and elastane fibres, 2XU has engineered a performance fabric to maximise moisture management while offering stretch for flexibility.

VAPOR MESH

Utilising a durable and lightweight mesh structure, 2XU has engineered a performance fabric to deliver superior moisture management and comfort.

VAPOR STRETCH

Featuring micro-filament polyester yarn with hydrophobic properties, this fabric offers supreme stretch and comfort. A lower denier (finer) yarn on the outside wicks moisture from the higher denier (thicker) yarn on the inside to keep the wearer comfortable and dry. Moisture managing and zero cling to the body.

X LITE LINING

Light-weight with superior breathability, this brief liner keeps the wearer dry and comfortable through every workout.

X STRETCH FLEECE

Engineered to offer an equilibrium environment between the skin and fabric, this premium membrane offers stretch for flexibility, a soft micro fleece inner plus superior waterproof and vapour release ratings.

EMBELLISHMENT OPTIONS

Customise your BSR garments by using one of the following embellishment options with your branding.



SCREEN PRINT

Screen printing is the most common method of textile printing, as it can be printed on almost all fabric types and provides long lasting prints with an accurate colour reproduction (based on Pantone C colour codes). Screen printing is the preferred method for designs consisting of few colours and not featuring too much detail. Due to the set-up fees for each individual colour used, screen printing is recommended for mid to larger order quantities from a costing point of view. Logos featuring a colour gradient or that are too fine in detail can not be screen printed.



HEAT TRANSFER

Heat transfer prints are designs pressed onto garments via high-temperature and heavy pressure. This printing method allows for both fine logo details and colour gradients as well as multiple colours without extra costs. With less durability than screen print or embroidery, we recommend cold machine wash only.



EMBROIDERY

Embroidery is the longest lasting embellishment method and provides a quality finish to garments. This method allows multiple colours per logo without any extra costs, and works on most fabric types. Whilst providing a nice finish on outer layers (e.g. jackets), embroidery is not ideal for larger back logos, and chest logos applied on a thin/breathable fabric. Embroidery is not available for small and intricate designs, or for colour gradients.



MEN'S

BSR COLLECTION



MEN'S BSR COLLECTION

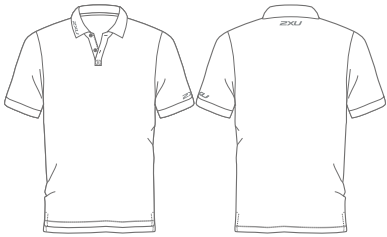

MR4896A

BSR Performance Polo

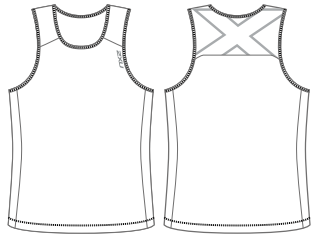

MR4819A

BSR Active Tank

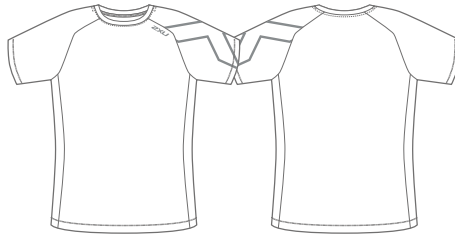

MR4818A

BSR Active S/S Tee

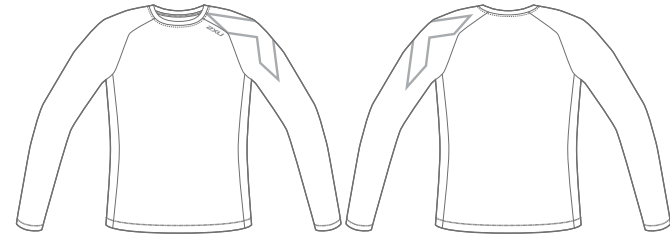

MR5158A

BSR Active L/S Shirt

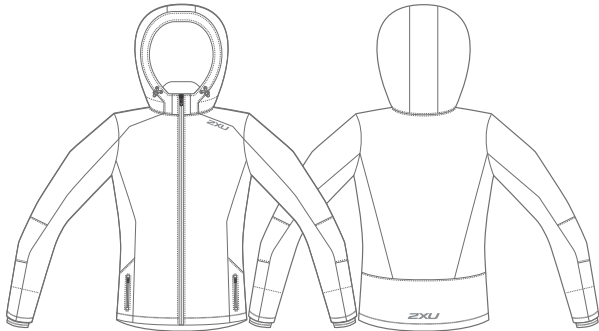

MR4821A

BSR Membrane Jacket

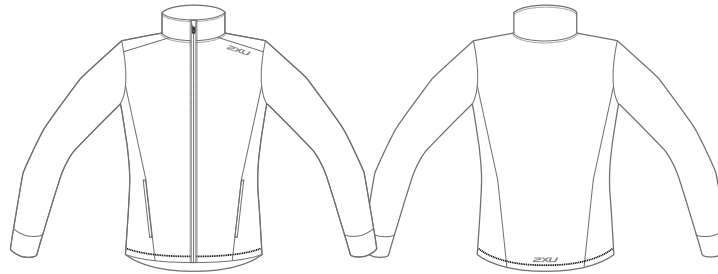

MR4823A

BSR Track Jacket

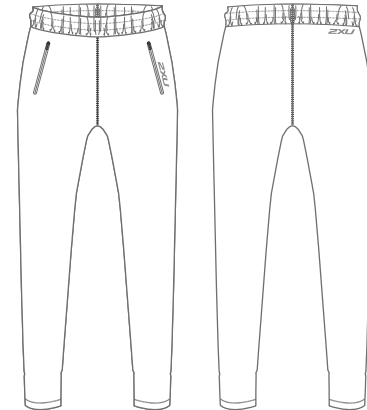

MR4825B

BSR Track Pant

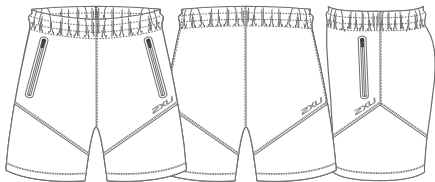

MR4827B

BSR 9" Parade Short

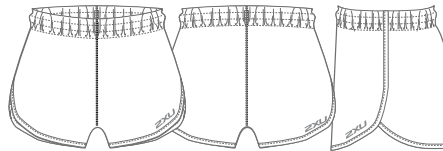

MR4829B

BSR 4" Run Short



MEN'S BSR PERFORMANCE POLO

MR4896A

COLOUR WAYS: BLACK, NAVY, WHITE

SIZE RANGE: 2XS - 5XL



GARMENT FEATURES

01. Semi-fitted, classic style polo.
02. Self fabric collar with two-button placket.
03. Short sleeves with self fabric armbands.
04. Side vents with tennis tail at hem for full range of motion.
05. Chafe-free flatlock seam construction.
06. Traditional 2XU branding.
07. Designed to meet off-field needs.

FABRIC BENEFITS

01. Utilising 2XU's breakthrough moisture management technology to keep you drier through high-filament yarns and cooler through our advanced knit structure.
02. POLYGIENE® odour technology ensures you stay fresh and odour-free. Wear more, wash less and reduce your environmental footprint.

EMBELLISHMENT RECOMMENDATIONS

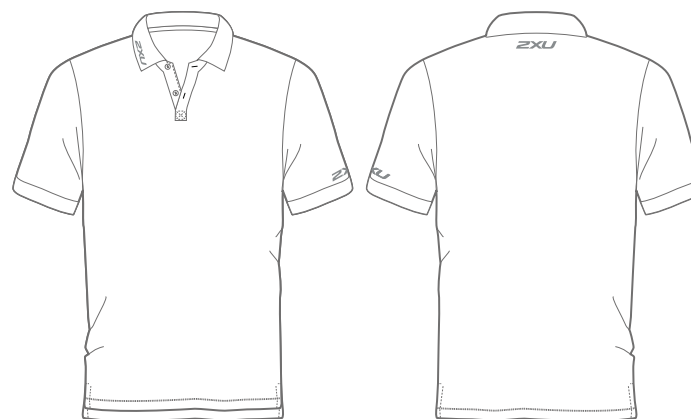

Levi is 188cm, 82kgs and wears a Medium

MEN'S BSR ACTIVE L/S SHIRT

MR5158A

COLOUR WAYS: BLACK, NAVY, WHITE

SIZE RANGE: 2XS - 5XL



GARMENT FEATURES

01. Semi-fitted, active style tee.
02. Crew neckline with neck band and interior taping for comfort and durability.
03. Long sleeves with raglan design.
04. Chafe-free flatlock seam construction.
05. X-device branding on the left sleeve.
06. Designed to meet on and off-field needs.

FABRIC BENEFITS

01. Utilising 2XU's breakthrough moisture management technology to keep you drier through high-filament yarns and cooler through our advanced knit structure.
02. POLYGIENE® odour technology ensures you stay fresh and odour-free. Wear more, wash less and reduce your environmental footprint.

EMBELLISHMENT RECOMMENDATIONS

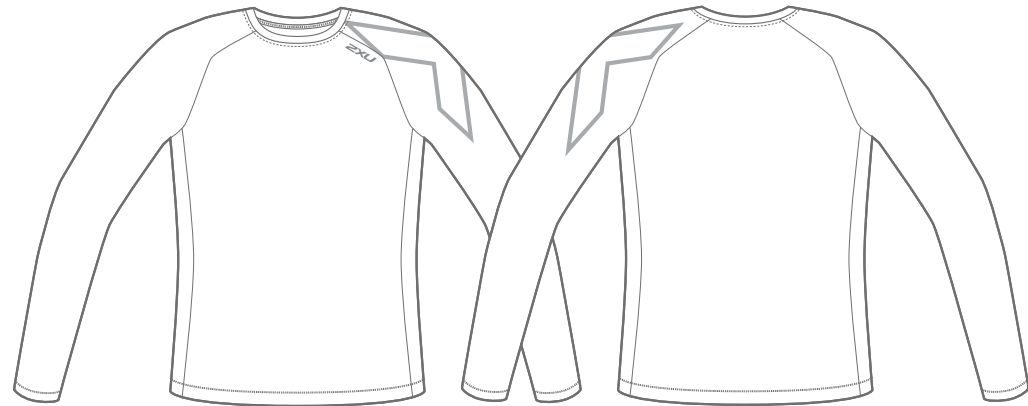

Levi is 188cm, 82kgs and wears a Medium

MEN'S BSR ACTIVE TANK

MR4819A

COLOUR WAYS: BLACK, NAVY, WHITE

SIZE RANGE: 2XS - 5XL



GARMENT FEATURES

01. Semi-fitted, active style tank.
02. Round neck line with neck bind.
03. Sleeveless with back yoke design.
04. Chafe-free flatlock seam construction.
05. X-device branding on the top back.
06. Designed to meet off-field needs.

FABRIC BENEFITS

01. Utilising 2XU's breakthrough moisture management technology to keep you drier through high-filament yarns and cooler through our advanced knit structure.
02. POLYGIENE® odour technology ensures you stay fresh and odour-free. Wear more, wash less and reduce your environmental footprint.

EMBELLISHMENT RECOMMENDATIONS

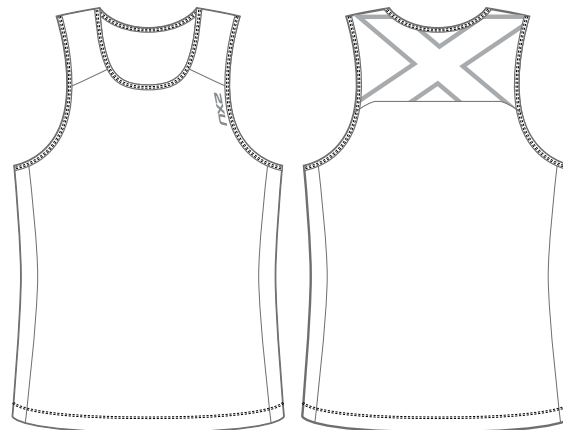

Levi is 188cm, 82kgs and wears a Medium

MEN'S BSR ACTIVE S/S TEE

MR4818A

COLOUR WAYS: BLACK, NAVY, WHITE

SIZE RANGE: 2XS - 5XL



GARMENT FEATURES

01. Semi-fitted, active style tee.
02. Crew neckline with neck band and interior taping for comfort and durability.
03. Short sleeves with raglan design.
04. Chafe-free flatlock seam construction.
05. X-device branding on the left sleeve.
06. Designed to meet on and off-field needs.

FABRIC BENEFITS

01. Utilising 2XU's breakthrough moisture management technology to keep you drier through high-filament yarns and cooler through our advanced knit structure.
02. POLYGIENE® odour technology ensures you stay fresh and odour-free. Wear more, wash less and reduce your environmental footprint.

EMBELLISHMENT RECOMMENDATIONS

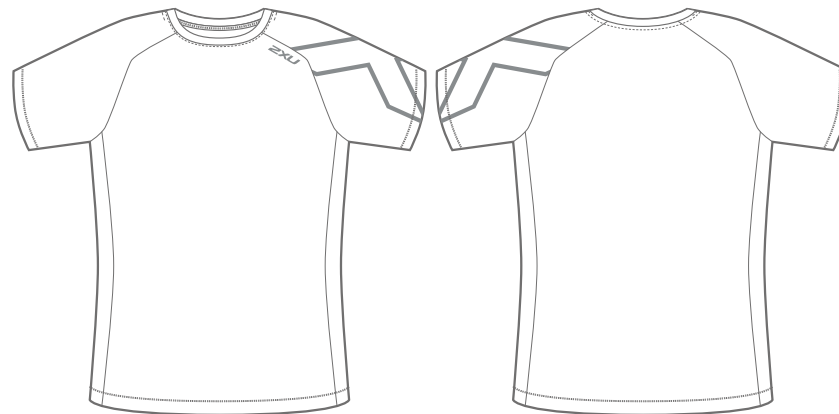

Levi is 188cm, 82kgs and wears a Medium

MEN'S BSR 4" RUN SHORT

MR4829B

COLOUR WAYS: BLACK, NAVY

SIZE RANGE: 2XS - 5XL

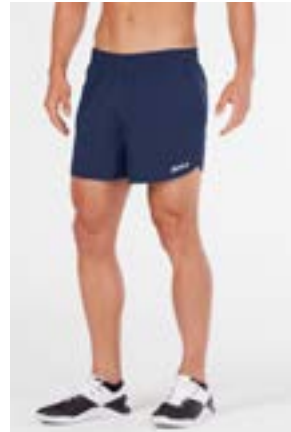

GARMENT FEATURES

01. 4-inch inseam length.
02. Anatomically shaped crossover hem, bound and raised at side seams to offer optimal range of movement.
03. 5cm width elasticated waistband with a hidden drawcord for a personalised and secure fit.
04. Internal stretch brief liner for comfort and an internal key pocket for convenient storage.
05. Designed to meet on-field needs.

FABRIC BENEFITS

01. Durable micro filament polyester yarns combined with an elastane component for unhindered movement.
02. Moisture wicking woven construction quickly removes sweat on contact with skin.
03. POLYGIENE® odour control technology, applied to the liner, ensures you stay fresh and odour free. Wear more, wash less and reduce your environmental footprint.
04. Zero cling against the body.

EMBELLISHMENT RECOMMENDATIONS

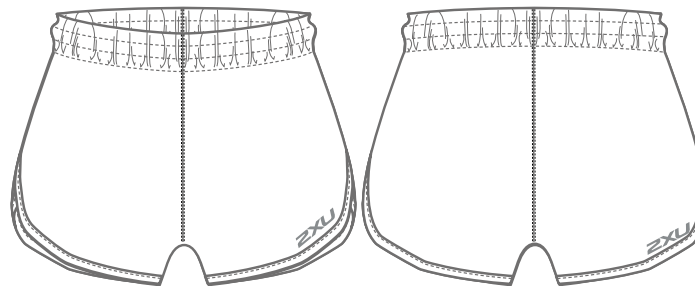

Levi is 188cm, 82kgs and wears a Medium

MEN'S BSR 9" PARADE SHORT

MR4827B

COLOUR WAYS: BLACK, NAVY

SIZE RANGE: 2XS - 5XL

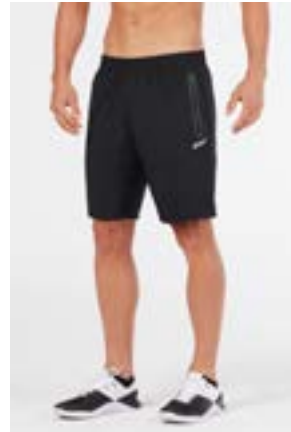

GARMENT FEATURES

01. 9-inch inseam length.
02. 5cm width elasticated waistband with a hidden drawcord for personalised and secure fit.
03. Internal stretch brief liner for comfort.
04. Side front zip pockets and internal key pocket for convenient storage.
05. Designed to meet on and off-field needs.

FABRIC BENEFITS

01. Durable micro filament polyester yarns combined with an elastane component for unhindered movement.
02. Moisture wicking woven construction quickly removes sweat on contact with skin.
03. POLYGIENE® odour control technology, applied to the liner, ensures you stay fresh and odour free. Wear more, wash less and reduce your environmental footprint.
04. Zero cling against the body.

EMBELLISHMENT RECOMMENDATIONS

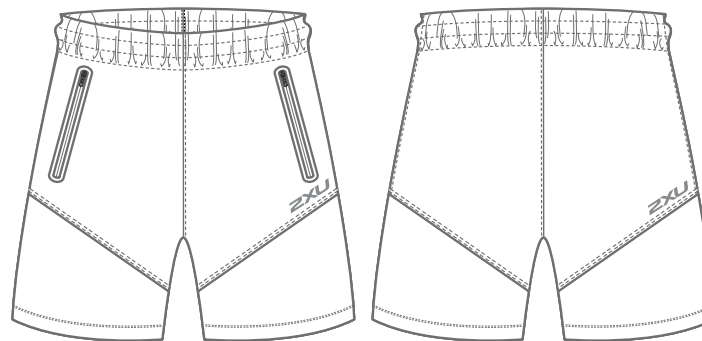

Levi is 188cm, 82kgs and wears a Medium

MEN'S BSR TRACK JACKET

MR4823A

COLOUR WAYS: BLACK, NAVY

SIZE RANGE: 2XS - 5XL



GARMENT FEATURES

01. Semi-fitted style with articulated back hem to provide extra coverage.
02. Stand-up collar for warmth and protection.
03. Full front zipper.
04. Side front zip pockets for convenient storage.
05. Chafe-free flatlock seam construction.
06. Designed to meet on and off-field needs.

FABRIC BENEFITS

01. A light-weight, french-terry backed, flexible, 3D mesh offers thermal regulation properties and optimal range of movement.
02. Moisture-wicking knit construction for essential moisture management.

EMBELLISHMENT RECOMMENDATIONS

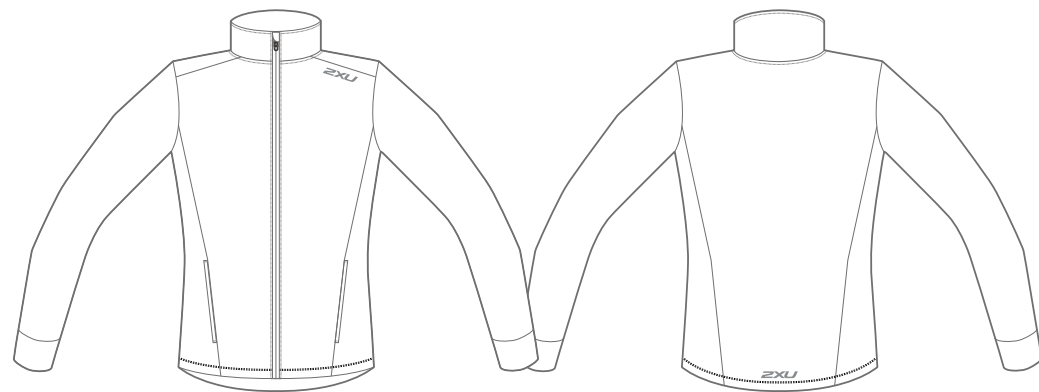

Levi is 188cm, 82kgs and wears a Medium

MEN'S BSR TRACK PANT

MR4825B

COLOUR WAYS: BLACK, NAVY

SIZE RANGE: 2XS - 5XL



GARMENT FEATURES

01. Semi-fitted style with tapered leg.
02. 5cm width elasticated waistband with a hidden drawcord for personalised and secure fit.
03. Bonded side front zip pockets for convenient storage.
04. Designed to meet off-field needs.

FABRIC BENEFITS

01. A light-weight, french-terry backed, flexible, 3D mesh offers thermal regulation properties and optimal range of movement.
02. Moisture-wicking knit construction for essential moisture management.

EMBELLISHMENT RECOMMENDATIONS

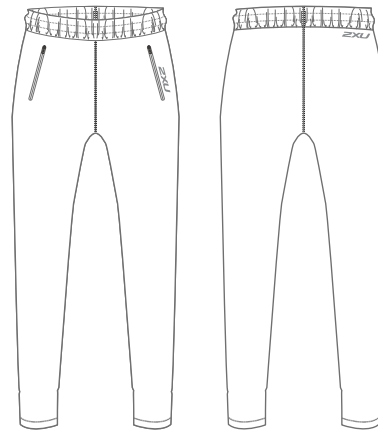

Levi is 188cm, 82kgs and wears a Medium

MEN'S BSR MEMBRANE JACKET

MR4821A

COLOUR WAYS: BLACK, NAVY

SIZE RANGE: 2XS - 5XL



GARMENT FEATURES

01. Semi-fitted style with articulated back hem to provide extra coverage.
02. Hood boasts an integrated bungee cord for personalised coverage.
03. Detachable hood for a customised look.
04. High collar with an internal zip guard.
05. Full front waterproof zipper.
06. Side front waterproof zip pockets for convenient storage.

FABRIC BENEFITS

01. Utilising fully waterproof fabric, coupled with advanced moisture control to create the perfect micro climate, you stay warm and dry.
02. Soft internal cuff and collar for comfort and added insulation.
03. Fleece lined front pockets for softness and warmth next to skin.

EMBELLISHMENT RECOMMENDATIONS

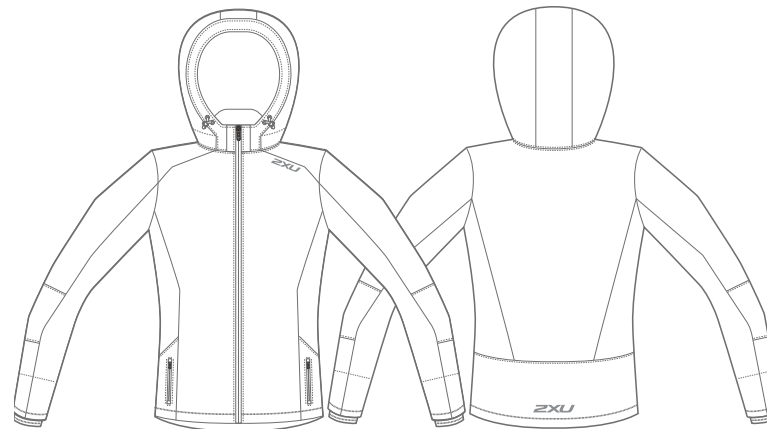

Levi is 188cm, 82kgs and wears a Medium



WOMEN'S

BSR COLLECTION

WOMEN'S BSR RUN COLLECTION

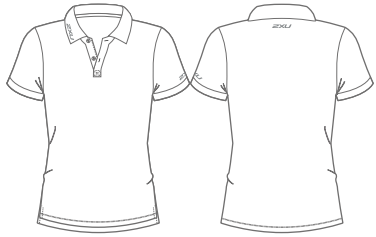

WR4897A
BSR Performance Polo

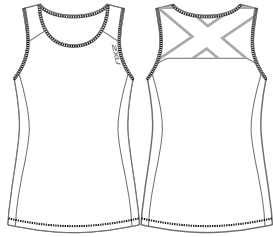

WR4817A
BSR Active Tank

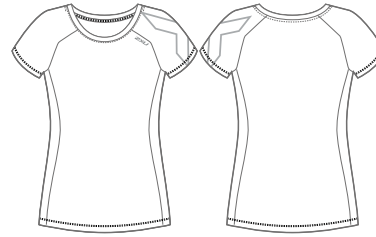

WR4816A
BSR Active S/S Tee

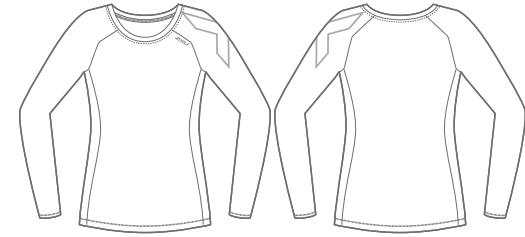

WR5159A
BSR Active L/S Shirt

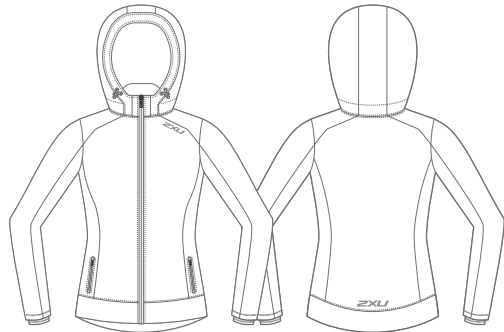

WR4820A
BSR Membrane Jacket

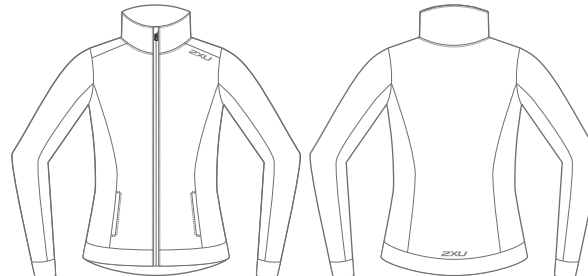

WR4822A
BSR Track Jacket

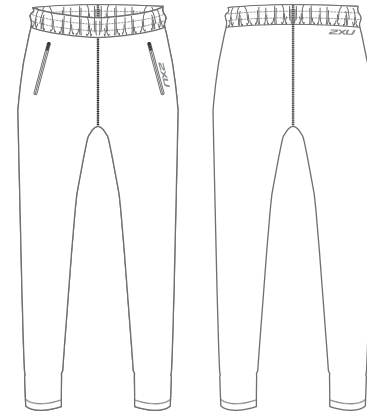

WR4824B
BSR Track Pant

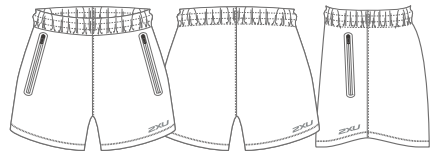

WR4826B
BSR 5" Parade Short

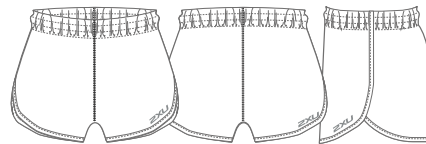

WR4828B
BSR 3" Run Short



WOMEN'S BSR PERFORMANCE POLO

WR4897A

COLOUR WAYS: BLACK, NAVY, WHITE

SIZE RANGE: 2XS -4XL



GARMENT FEATURES

01. Semi-fitted, classic style polo.
02. Self fabric collar with two-button placket.
03. Short sleeves with self fabric armbands.
04. Side vents with tennis tail at hem for full range of motion.
05. Chafe-free flatlock seam construction.
06. Traditional 2XU branding.
07. Designed to meet off-field needs.

FABRIC BENEFITS

01. Utilising 2XU's breakthrough moisture management technology to keep you drier through high-filament yarns and cooler through our advanced knit structure.
02. POLYGIENE® odour technology ensures you stay fresh and odour-free. Wear more, wash less and reduce your environmental footprint.

EMBELLISHMENT RECOMMENDATIONS

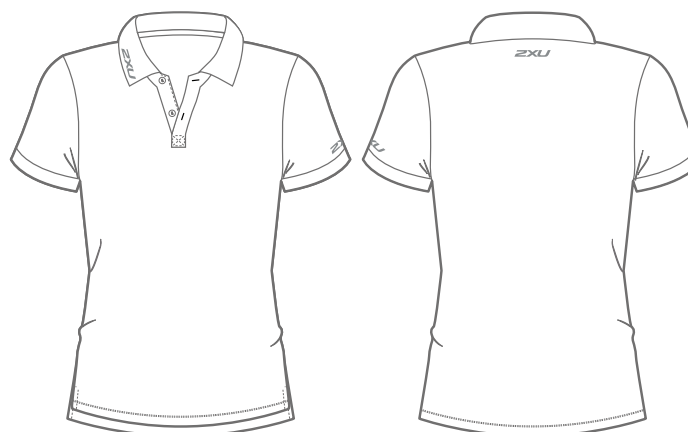

WOMEN'S BSR ACTIVE L/S SHIRT

WR5159A

COLOUR WAYS: BLACK, NAVY, WHITE

SIZE RANGE: 2XS -4XL



GARMENT FEATURES

01. Semi-fitted, active style tee.
02. Crew neckline with neck band and interior taping for comfort and durability.
03. Long sleeves with raglan design.
04. Chafe-free flatlock seam construction.
05. X-device branding on the left sleeve.
06. Designed to meet on and off-field needs.

FABRIC BENEFITS

01. Utilising 2XU's breakthrough moisture management technology to keep you drier through high-filament yarns and cooler through our advanced knit structure.
02. POLYGIENE® odour technology ensures you stay fresh and odour-free. Wear more, wash less and reduce your environmental footprint.

EMBELLISHMENT RECOMMENDATIONS

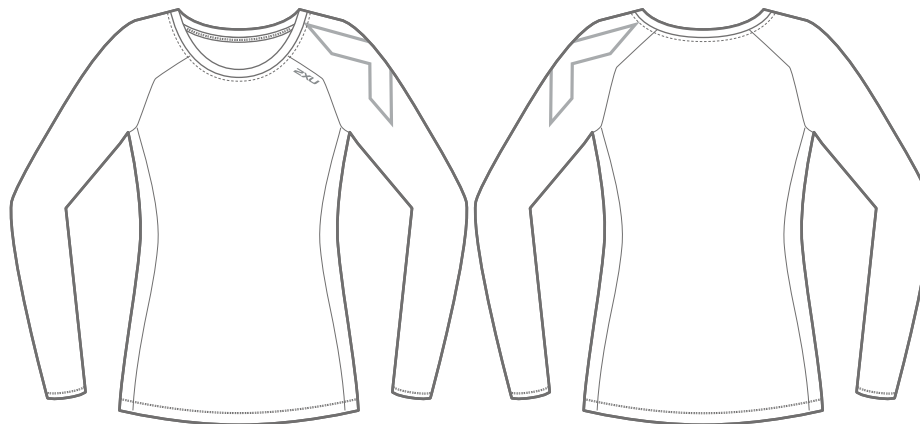

Hannah is 170cm, 60kgs and wears a Small

WOMEN'S BSR ACTIVE TANK

WR4817A

COLOUR WAYS: BLACK, NAVY, WHITE

SIZE RANGE: 2XS -4XL



GARMENT FEATURES

01. Semi-fitted, active style tank.
02. Round neck line with neck bind.
03. Sleeveless with back yoke design.
04. Chafe-free flatlock seam construction.
05. X-device branding on the top back.
06. Designed to meet off-field needs.

FABRIC BENEFITS

01. Utilising 2XU's breakthrough moisture management technology to keep you drier through high-filament yarns and cooler through our advanced knit structure.
02. POLYGIENE® odour technology ensures you stay fresh and odour-free. Wear more, wash less and reduce your environmental footprint.

EMBELLISHMENT RECOMMENDATIONS

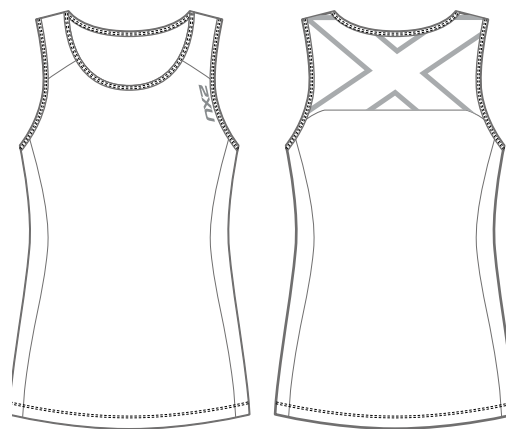

Hannah is 170cm, 60kgs and wears a Small

WOMEN'S BSR ACTIVE S/S TEE

WR4816A

COLOUR WAYS: BLACK, NAVY, WHITE

SIZE RANGE: 2XS -4XL

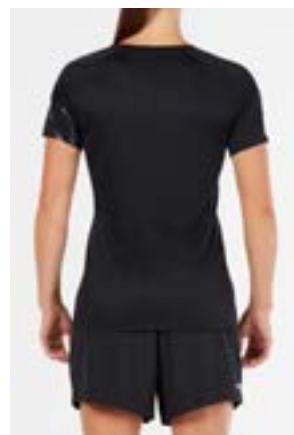

GARMENT FEATURES

01. Semi-fitted, active style tee.
02. Crew neckline with neck band and interior taping for comfort and durability.
03. Short sleeves with raglan design.
04. Chafe-free flatlock seam construction.
05. X-device branding on the left sleeve.
06. Designed to meet on and off-field needs.

FABRIC BENEFITS

01. Utilising 2XU's breakthrough moisture management technology to keep you drier through high-filament yarns and cooler through our advanced knit structure.
02. POLYGIENE® odour technology ensures you stay fresh and odour-free. Wear more, wash less and reduce your environmental footprint.

EMBELLISHMENT RECOMMENDATIONS

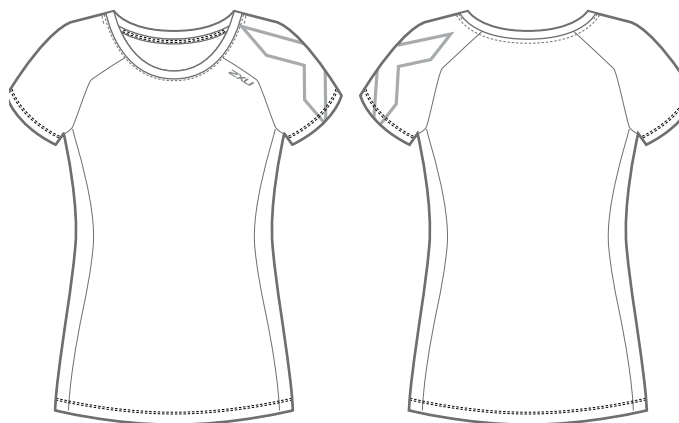

Hannah is 170cm, 60kgs and wears a Small

WOMEN'S BSR 3" RUN SHORT

WR4828B

COLOUR WAYS: BLACK, NAVY

SIZE RANGE: 2XS -4XL

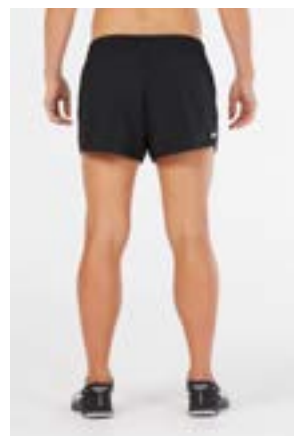
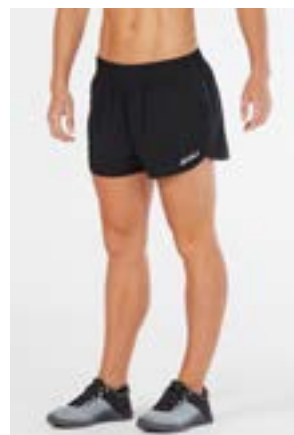

GARMENT FEATURES

01. 3-inch inseam length.
02. Anatomically shaped crossover hem, bound and raised at side seams to offer optimal range of movement.
03. 5cm width elasticated waistband with a hidden drawcord for a personalised and secure fit.
04. Internal stretch brief liner for comfort and an internal key pocket for convenient storage.
05. Designed to meet on-field needs.

FABRIC BENEFITS

01. Durable micro filament polyester yarns combined with an elastane component for unhindered movement.
02. Moisture wicking woven construction quickly removes sweat on contact with skin.
03. POLYGIENE® odour control technology, applied to the liner, ensures you stay fresh and odour free. Wear more, wash less and reduce your environmental footprint.
04. Zero cling against the body.

EMBELLISHMENT RECOMMENDATIONS

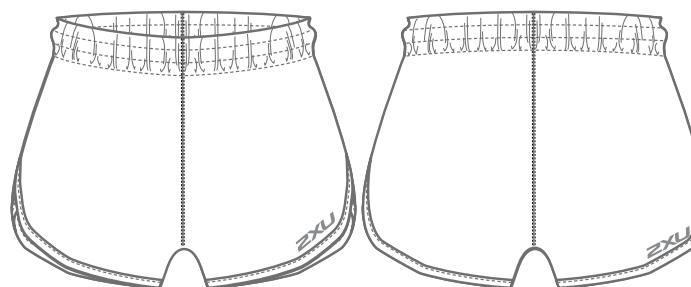

Hannah is 170cm, 60kgs and wears a Small

WOMEN'S BSR 5" PARADE SHORT

WR4826B

COLOUR WAYS: BLACK, NAVY

SIZE RANGE: 2XS -4XL

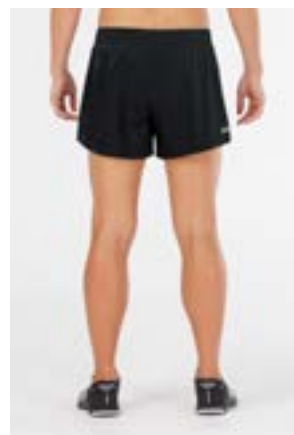

GARMENT FEATURES

01. 5-inch inseam length.
02. 5cm width elasticated waistband with a hidden drawcord for personalised and secure fit.
03. Internal stretch brief liner for comfort.
04. Side front zip pockets and internal key pocket for convenient storage.
05. Designed to meet on and off-field needs.

FABRIC BENEFITS

01. Durable micro filament polyester yarns combined with an elastane component for unhindered movement.
02. Moisture wicking woven construction quickly removes sweat on contact with skin.
03. POLYGIENE® odour control technology, applied to the liner, ensures you stay fresh and odour free. Wear more, wash less and reduce your environmental footprint.
04. Zero cling against the body.

EMBELLISHMENT RECOMMENDATIONS

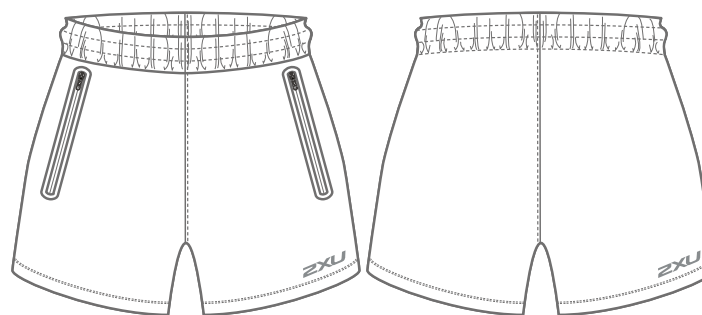

Hannah is 170cm, 60kgs and wears a Small

WOMEN'S BSR TRACK JACKET

WR4822A

COLOUR WAYS: BLACK, NAVY

SIZE RANGE: 2XS -4XL



GARMENT FEATURES

01. Semi-fitted style with articulated back hem to provide extra coverage.
02. Stand-up collar for warmth and protection.
03. Full front zipper.
04. Side front zip pockets for convenient storage.
05. Chafe-free flatlock seam construction.
06. Designed to meet on and off-field needs.

FABRIC BENEFITS

01. A light-weight, french-terry backed, flexible, 3D mesh offers thermal regulation properties and optimal range of movement.
02. Moisture-wicking knit construction for essential moisture management.

EMBELLISHMENT RECOMMENDATIONS

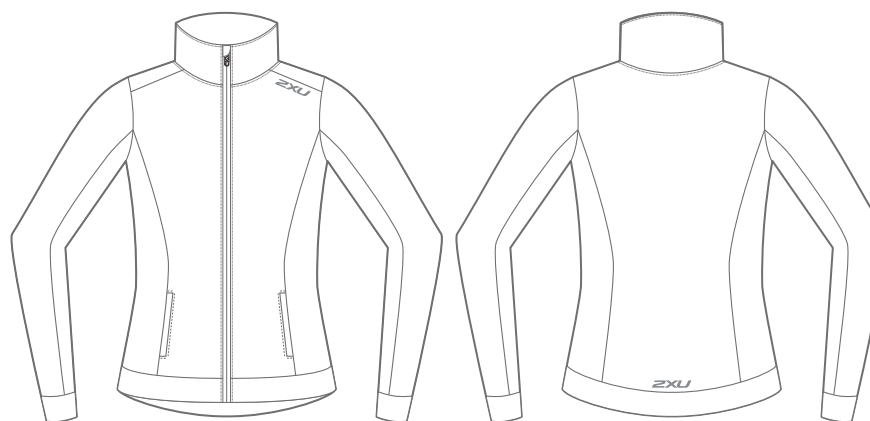

Hannah is 170cm, 60kgs and wears a Small

WOMEN'S BSR TRACK PANT

WR4824B

COLOUR WAYS: BLACK, NAVY

SIZE RANGE: 2XS -4XL



GARMENT FEATURES

01. Semi-fitted style with tapered leg.
02. 5cm width elasticated waistband with a hidden drawcord for personalised and secure fit.
03. Bonded side front zip pockets for convenient storage.
04. Designed to meet off-field needs.

FABRIC BENEFITS

01. A light-weight, french-terry backed, flexible, 3D mesh offers thermal regulation properties and optimal range of movement.
02. Moisture-wicking knit construction for essential moisture management.

EMBELLISHMENT RECOMMENDATIONS

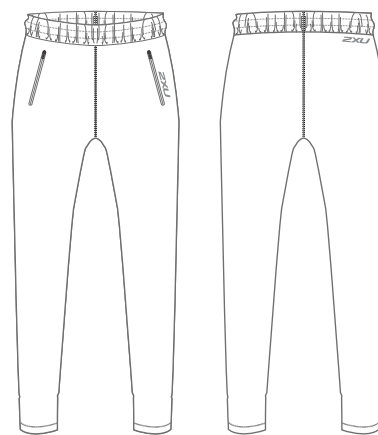

WOMEN'S MEMBRANE JACKET

WR4820A

COLOUR WAYS: BLACK, NAVY

SIZE RANGE: 2XS -4XL



GARMENT FEATURES

01. Semi-fitted style with articulated back hem to provide extra coverage.
02. Hood boasts an integrated bungee cord for personalised coverage.
03. Detachable hood for a customised look.
04. High collar with an internal zip guard.
05. Full front waterproof zipper.
06. Side front waterproof zip pockets for convenient storage.

FABRIC BENEFITS

01. Utilising fully waterproof fabric, coupled with advanced moisture control to create the perfect micro climate, you stay warm and dry.
02. Soft internal cuff and collar for comfort and added insulation.
03. Fleece lined front pockets for softness and warmth next to skin.

EMBELLISHMENT RECOMMENDATIONS

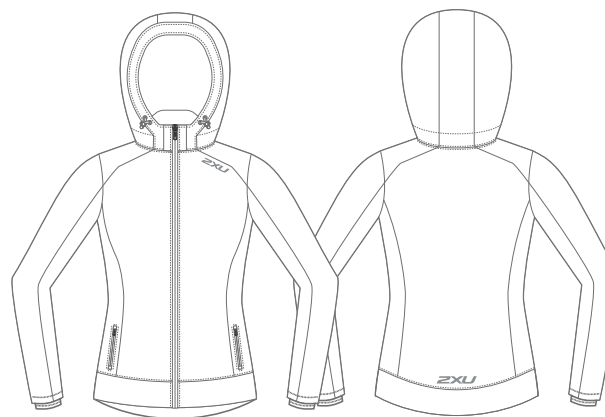

Hannah is 170cm, 60kgs and wears a Small



ESSENTIALS

BSR COLLECTION

ESSENTIALS BSR COLLECTION



UR1188F
Run Cap

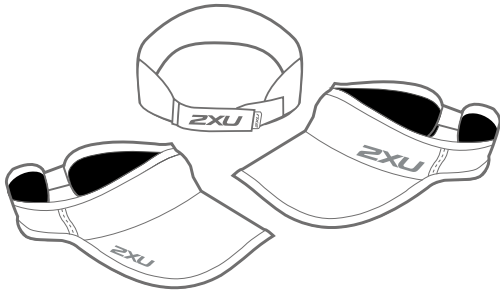

UA1150F
Run Visor

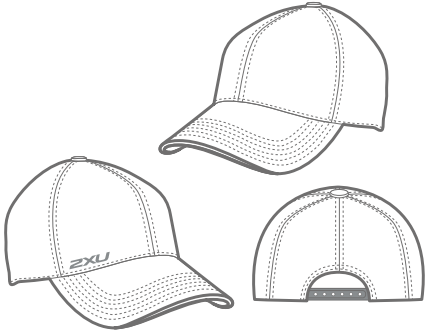

UQ4989G
Casual Cap

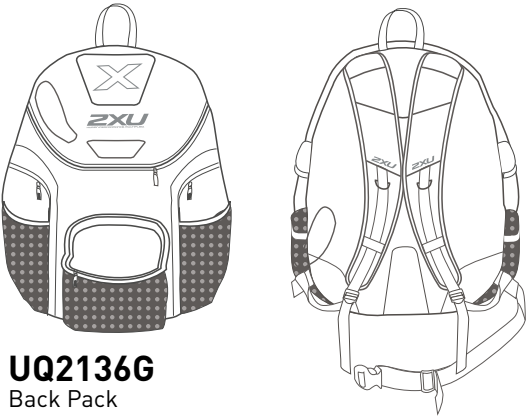

UQ2136G
Back Pack

UNISEX RUN CAP

UR1188F

COLOUR WAYS: BLACK, WHITE

SIZE RANGE: OSFA



GARMENT FEATURES

- 01. Six-panel, curved peak design.
- 02. Mesh panelling for ventilation.
- 03. Adjustable hook and loop strap closure to ensure a secure fit.
- 04. Soft internal elastic sweatband for lasting comfort.
- 05. Traditional 2XU branding.
- 06. Designed to meet on-field needs.

FABRIC BENEFITS

- 01. Durable light-weight woven structure for premium moisture management and breathability.

EMBELLISHMENT RECOMMENDATIONS



UNISEX RUN VISOR

UA1150F

COLOUR WAYS: BLACK, WHITE

SIZE RANGE: OSFA



GARMENT FEATURES

01. Anatomic panelling, curved peak design for a performance fit.
02. Adjustable hook and loop strap closure to ensure a secure fit.
03. Soft internal elastic sweatband for lasting comfort.
04. Traditional 2XU branding.
05. Designed to meet on-field needs.

FABRIC BENEFITS

01. Durable light-weight woven structure for premium moisture management and breathability.

EMBELLISHMENT RECOMMENDATIONS

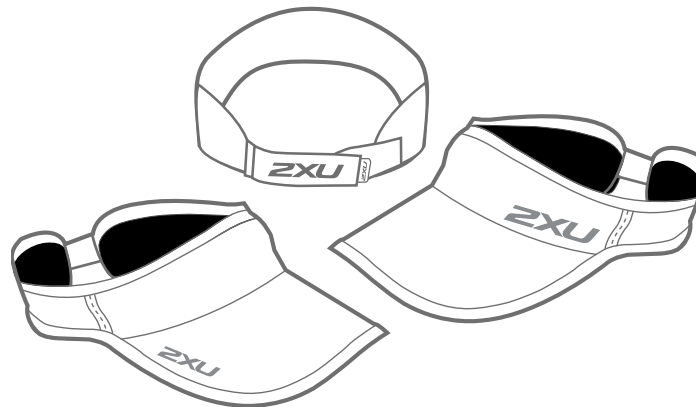

UNISEX CASUAL CAP

UQ4989G

COLOUR WAYS: BLACK

SIZE RANGE: OSFA



GARMENT FEATURES

01. Classic six-panel design.
02. Curved peak, providing adequate shade from the sun.
03. Lightweight and quick drying.
04. Snapback strap for a customised fit.
05. Designed to meet on and off-field needs.

FABRIC BENEFITS

01. High filament cross section yarns for the ultimate in moisture management and breathability.
02. Durable and lightweight mesh structure ensures quick dry and comfort.

EMBELLISHMENT RECOMMENDATIONS

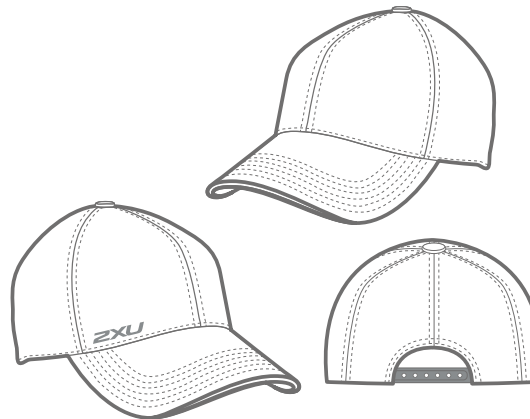

UNISEX BACKPACK

UQ2136G

COLOUR WAYS: BLACK

SIZE RANGE: OSFA



GARMENT FEATURES

- 01. Ergonomic design with fully adjustable and padded straps for a customised fit.
- 02. Padded laptop pouch, easy access key storage and side storage for water bottles.
- 03. 20L capacity.

FABRIC BENEFITS

- 01. Highly durable shell outer offers water and abrasion resistance.
- 02. Internal padding zones for essential comfort.

EMBELLISHMENT RECOMMENDATIONS

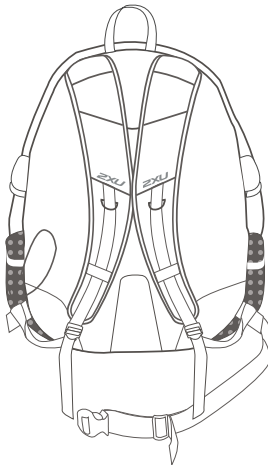



SIZING CHARTS

BSR COLLECTION

BSR COLLECTION SIZING INFORMATION - MEN'S

MEN'S SIZING

MEASUREMENT (circumferences)		2XS	XS	S	M	L	XL	2XL	3XL	4XL	5XL
Chest	cm	83-87	88-92	93-97	98-102	103-107	108-112	113-117	118-122	123-127	123-127
	inches	32 ⁵ / ₈ -34 ¹ / ₄	34 ⁵ / ₈ -36 ¹ / ₄	36 ⁵ / ₈ -38 ¹ / ₄	38 ⁵ / ₈ -40 ¹ / ₈	40 ¹ / ₂ -42 ¹ / ₈	42 ¹ / ₂ -44 ¹ / ₈	44 ¹ / ₂ -46	46 ¹ / ₂ -48	48 ³ / ₈ -50	50 ³ / ₈ -52
Waist	cm	65-69	70-74	75-79	80-84	85-89	90-94	95-99	100-104	105-109	110-114
	inches	25 ¹ / ₂ -27 ¹ / ₈	27 ¹ / ₂ -29 ¹ / ₈	29 ¹ / ₂ -31 ¹ / ₈	31 ¹ / ₂ -33	33 ¹ / ₂ -35	35 ¹ / ₈ -37	37 ³ / ₈ -39	39 ³ / ₈ -41	41 ³ / ₈ -42 ⁷ / ₈	43 ³ / ₈ -44 ⁷ / ₈



Levi is 188cm, 82kgs and wears a Medium

BSR COLLECTION SIZING INFORMATION - WOMEN'S

WOMEN'S SIZING

MEASUREMENT (circumferences)		2XS	XS	S	M	L	XL	2XL	3XL	4XL
Bust	cm	78-82	83-87	88-92	93 - 97	98 -102	103-107	108-112	113-117	118-122
	inches	30 ³ / ₄ -32 ¹ / ₄	32 ⁵ / ₈ -34 ¹ / ₄	34 ⁵ / ₄ -36 ¹ / ₄	36 ⁵ / ₈ -38 ¹ / ₄	38 ⁵ / ₈ -40 ¹ / ₄	40 ¹ / ₂ -42 ¹ / ₈	42 ¹ / ₂ -44 ¹ / ₈	44 ¹ / ₂ -46	46 ¹ / ₄ -48
Waist	cm	58-62	63-67	68-72	73-77	78-82	83-87	88-92	93-97	98-102
	inches	22 ³ / ₈ -24 ³ / ₈	24 ³ / ₄ -26 ³ / ₈	26 ³ / ₄ -28 ³ / ₈	28 ³ / ₄ -30 ³ / ₈	30 ³ / ₄ -32 ¹ / ₄	32 ³ / ₄ -34 ¹ / ₄	34 ⁵ / ₈ -36 ¹ / ₄	36 ⁵ / ₈ -38 ¹ / ₄	38 ¹ / ₂ -45
Hip	cm	86-90	91-95	96-100	101-105	106-110	111-115	116-120	121-125	126-131
	inches	33 ⁷ / ₈ -35 ¹ / ₂	35 ⁷ / ₈ -37 ³ / ₈	37 ³ / ₄ -39 ³ / ₈	39 ³ / ₄ -41 ³ / ₈	41 ³ / ₄ -43 ³ / ₈	43 ³ / ₄ -54 ¹ / ₄	45 ⁵ / ₈ -47 ¹ / ₄	47 ⁵ / ₈ -49 ¹ / ₄	49 ¹ / ₂ -51 ¹ / ₂



Hannah is 170cm, 60kgs and wears a Small

PERFORM X RUN

CUSTOM COLLECTION

2XU
CUSTOM



PERFORMX
RUN COLLECTION

BULK DYE AND SUBLIMATION MANUFACTURING



BULK-DYE

Our bulk-dye offering presents 3 colour options of black, navy and red. When selecting a bulk-dye garment 3 types of logo embellishment are available;



EMBROIDERY

Embroidery is the longest lasting embellishment method and provides a quality finish to garments. Whilst providing a nice finish on outer layers (e.g. jackets), embroidery is not ideal for larger back logos and chest logos applied on a thin/breathable fabric.



SCREEN PRINT

Screen printing is the most common method of textile printing, as it can be printed on almost all fabric types and provides long lasting prints with an accurate colour reproduction. Due to the set-up fees for each individual colour used, screen printing is recommended for medium to large volume orders.



HEAT TRANSFER

Heat transfer prints are pressed onto garments via high-temperature and heavy pressure. With less durability than screen print or embroidery, we strongly recommend cold machine wash only.



SUBLIMATION

Sublimation printing uses ink or dye to transfer your artwork into your desired garment. Sometimes referred to as "dye-sublimation printing," this process has many unique elements to it which allow you to have full creative freedom when customising your apparel. Traditionally this process is the most popular in the industry as it is so versatile allowing you to receive the exact colour and design you desire.

PERFORM X FABRIC TECHNICAL INFORMATION

HI~FIL+

Utilising high filament technology, 2XU has engineered a performance fabric to maximise moisture management. Cross-channeled yarns wick vapour from the inner to outer layers in order to keep the wearer as dry and as comfortable as possible, while a mesh structure promises breathability. HI FIL+ includes Polygiene® odour control technology ensuring you stay fresh and odour free. Wear more, wash less and reduce your environmental footprint.

VAPOR

A lightweight, high-gauge woven fabric with a 4-way mechanical stretch. A solution that blocks out wind while remaining light and packable. High-filament yarns wick moisture away from the body to keep the wearer comfortable, dry and with zero cling to the body.



Polygiene is the world's leading permanent Anti-Bacterial treatment. As the most respected and customer recognised permanent Anti-Bacterial treatment on the market, Polygiene prevents the growth of odour-causing bacteria and fungi at the source, permanently. Only active on the textile, it does not interfere with the skins natural bacterial flora and does not wash out, as the technology is bound and permanently integrated into the fabric. Polygiene means no more washing after every wear.

ACTIVE LINER

For extreme moisture control through hot conditions, 2XU's ACTIVE LINING is built with polyester filament yarns to keep the wearer dry and chafe-free.

ICEX

Cooling technology that actively lowers skin temperature upon contact with skin. Engineered from high filament yarns, this impressive fabric keeps you cool in the heat and wicks moisture to keep you dry. Excellent stretch and recovery memory to move with the body.

MEN'S

PERFORM X CUSTOM RUN COLLECTION



MEN'S PERFORM X CUSTOM RUN COLLECTION

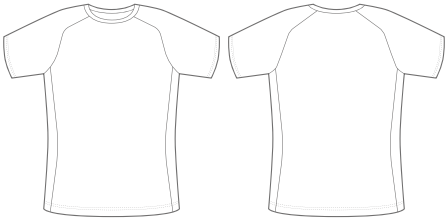

MX5702A 
Men's Perform X Run Tee

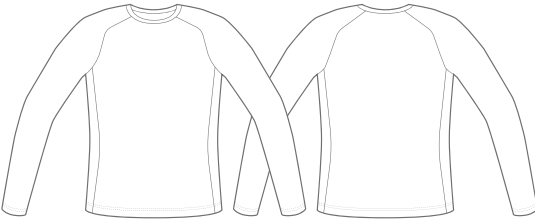

MX5706A 
Men's Perform X Longsleeve Run Top

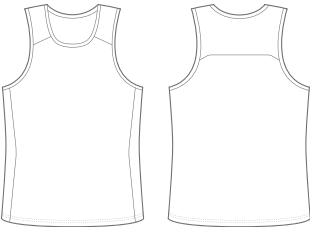

MX5704A 
Men's Perform X Run Tank

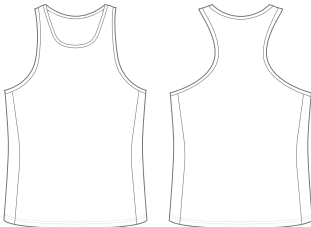

MX5700A 
Men's Perform X Racer Back Tank

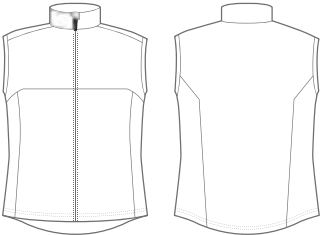

MX5714A
Men's Perform X Lightweight Run Vest

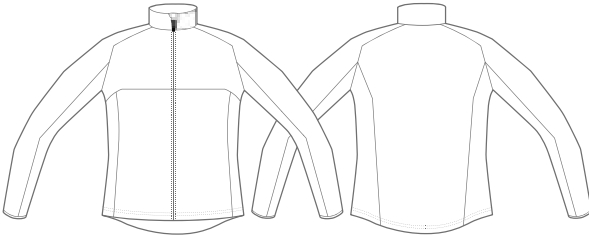

MX5712A
Men's Perform X Lightweight Run Jacket

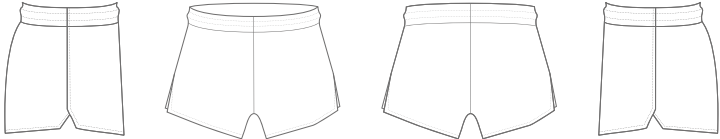

MX5708B
Men's Perform X 3-Inch Run Short



MX5710B
Men's Perform X 5-Inch Run Short

MEN'S PERFORM X RUN TEE

MX5702A

SIZE RANGE: 2XS - 5XL

SUBLIMATION or BULK DYE (black, red and navy)



GARMENT FEATURES

01. Semi-fitted, active style tee.
02. Crew neckline with neck band and interior taping for comfort and durability.
03. Short sleeve with raglan design.
04. Chafe-free flatlock seam construction.
05. Engineered to meet all performance needs.

FABRIC BENEFITS

HI FIL

Utilising 2XU's breakthrough moisture management technology. Keeps you drier through high-filament yarns and cooler through our advanced knit structure.

Polygiene®

Odour control technology ensures you stay fresh and odour-free. Wear more, wash less and reduce your environmental footprint.

BULK DYE LOGO EMBELLISHMENT OPTIONS

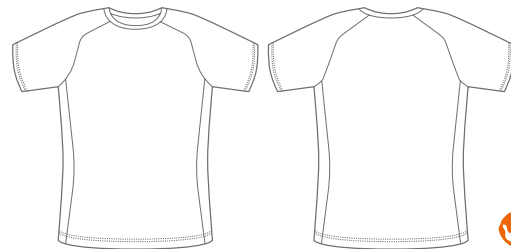

Levi is 188cm, 82kgs and wears a Medium

Garment pictured is sublimated, available bulk dye colours are black, navy and red.

MEN'S PERFORM X LONGSLEEVE RUN TOP

MX5706A

SIZE RANGE: 2XS - 5XL

SUBLIMATION or BULK DYE (black, red and navy)



GARMENT FEATURES

01. Semi-fitted, active style long sleeve top.
02. Crew neckline with neck band and interior taping for comfort and durability.
03. Long sleeve with raglan design.
04. Chafe-free flatlock seam construction.
05. Engineered to meet all performance needs.

FABRIC BENEFITS

HI FIL

Utilising 2XU's breakthrough moisture management technology. Keeps you drier through high-filament yarns and cooler through our advanced knit structure.

Polygiene®

Odour control technology ensures you stay fresh and odour-free. Wear more, wash less and reduce your environmental footprint.

BULK DYE LOGO EMBELLISHMENT OPTIONS

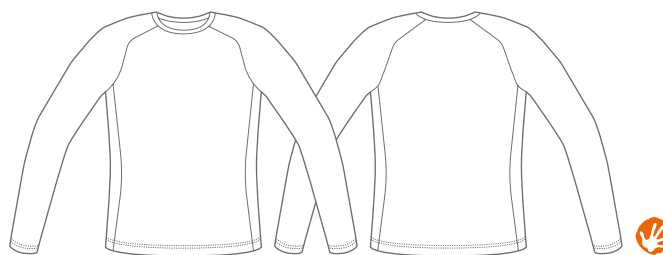

Levi is 188cm, 82kgs and wears a Medium

Garment pictured is sublimated, available bulk dye colours are black, navy and red.

MEN'S PERFORM X RUN TANK

MX5704A

SIZE RANGE: 2XS - 5XL

SUBLIMATION or BULK DYE (black, red and navy)



GARMENT FEATURES

01. Semi-fitted, active style tank.
02. Round neckline with neck bind.
03. Forward shoulder seam and back yoke panel.
04. Chafe-free flatlock seam construction.
05. Engineered to meet all performance needs.

FABRIC BENEFITS

HI FIL

Utilising 2XU's breakthrough moisture management technology. Keeps you drier through high-filament yarns and cooler through our advanced knit structure.

Polygiene®

Odour control technology ensures you stay fresh and odour-free. Wear more, wash less and reduce your environmental footprint.

BULK DYE LOGO EMBELLISHMENT OPTIONS

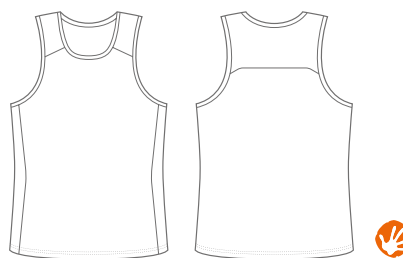

Levi is 188cm, 82kgs and wears a Medium

Garment pictured is sublimated, available bulk dye colours are black, navy and red.

MEN'S PERFORM X RACER BACK TANK

MX5700A

SIZE RANGE: 2XS - 5XL

SUBLIMATION or BULK DYE (black, red and navy)

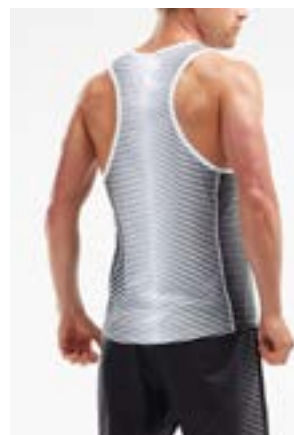

GARMENT FEATURES

01. Semi-fitted, racer back style tank.
02. Round neckline with neck bind.
03. Chafe-free flatlock seam construction.
04. Engineered to meet all performance needs.

FABRIC BENEFITS

HI FIL

Utilising 2XU's breakthrough moisture management technology. Keeps you drier through high-filament yarns and cooler through our advanced knit structure.

Polygiene®

Odour control technology ensures you stay fresh and odour-free. Wear more, wash less and reduce your environmental footprint.

BULK DYE LOGO EMBELLISHMENT OPTIONS

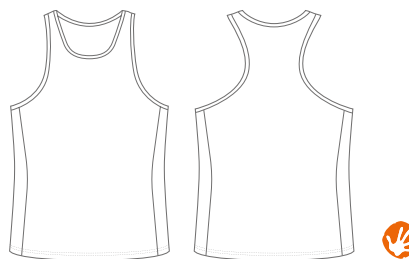

Levi is 188cm, 82kgs and wears a Medium

Garment pictured is sublimated, available bulk dye colours are black, navy and red.

MEN'S PERFORM X LIGHTWEIGHT RUN VEST

MX5714A

SIZE RANGE: 2XS - 5XL

SUBLIMATION or BULK DYE (black, red and navy)



GARMENT FEATURES

01. Semi-fitted style with articulated back hem to provide extra coverage.
02. Stand-up collar for warmth and protection.
03. Full front zipper.
04. Sleeveless trans-seasonal style, ideal for layering.
05. Engineered to meet all performance needs.

FABRIC BENEFITS

VAPOR

A lightweight, high-gauge woven fabric with a four-way mechanical stretch. A solution that blocks out wind while remaining light and packable. High-filament yarns wick moisture away from the body to keep the wearer comfortable, dry and with zero cling to the body.

BULK DYE LOGO EMBELLISHMENT OPTIONS

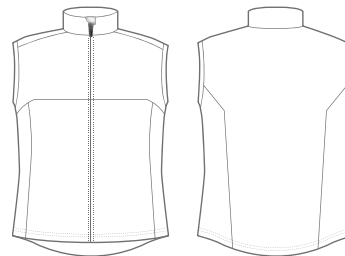

Levi is 188cm, 82kgs and wears a Medium

Garment pictured is sublimated, available bulk dye colours are black, navy and red.

MEN'S PERFORM X LIGHTWEIGHT RUN JACKET

MX5712A

SIZE RANGE: 2XS - 5XL

SUBLIMATION or BULK DYE (black, red and navy)



GARMENT FEATURES

01. Semi-fitted style with articulated back hem to provide extra coverage.
02. Stand-up collar for warmth and protection.
03. Full front zipper.
04. Raglan sleeves for increased range of movement.
05. Engineered to meet all performance needs.

FABRIC BENEFITS

VAPOR

A lightweight, high-gauge woven fabric with a four-way mechanical stretch. A solution that blocks out wind while remaining light and packable. High-filament yarns wick moisture away from the body to keep the wearer comfortable, dry and with zero cling to the body.

BULK DYE LOGO EMBELLISHMENT OPTIONS

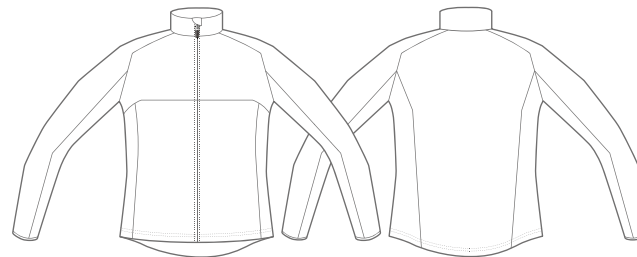

Levi is 188cm, 82kgs and wears a Medium

Garment pictured is sublimated, available bulk dye colours are black, navy and red.

MEN'S PERFORM X 3-INCH RUN SHORT

MX5708B

SIZE RANGE: 2XS - 5XL

SUBLIMATION or BULK DYE (black, red and navy)

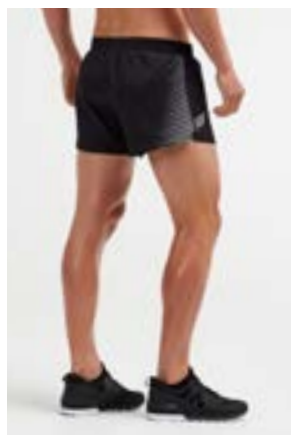

GARMENT FEATURES

01. 3-inch inseam length.
02. Anatomically shaped crossover hem, raised and split at the side seams to offer a range of movement.
03. 4cm width elasticated waistband with an internal drawcord for a personalised and secure fit.
04. Internal stretch brief liner for comfort and coverage.
05. Internal key pocket for convenient storage.
06. Engineered to meet all performance needs.

FABRIC BENEFITS

VAPOR

A lightweight, high-gauge woven fabric with a four-way mechanical stretch. A solution that blocks out wind while remaining light and packable. High-filament yarns wick moisture away from the body to keep the wearer comfortable, dry and with zero cling to the body.

ACTIVE LINER

For extreme moisture control through hot conditions, 2XU's ACTIVE LINING is built with polyester filament yarns to keep the wearer dry and chafe-free.

BULK DYE LOGO EMBELLISHMENT OPTIONS

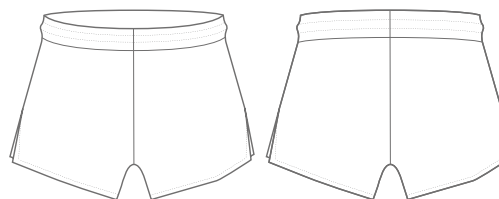

Levi is 188cm, 82kgs and wears a Medium

Garment pictured is sublimated, available bulk dye colours are black, navy and red.

MEN'S PERFORM X 5-INCH RUN SHORT

MX5710B

SIZE RANGE: 2XS - 5XL

SUBLIMATION or BULK DYE (black, red and navy)

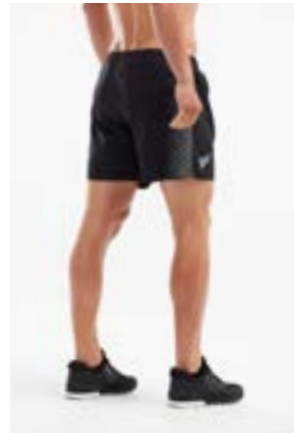

GARMENT FEATURES

01. 5-inch inseam length.
02. Straight hem design with split at side seams to offer a range of movement.
03. 4cm width elasticated waistband with an internal drawcord for a personalised and secure fit.
04. Internal stretch brief liner for comfort and coverage.
05. Internal key pocket for convenient storage.
06. Engineered to meet all performance needs.

FABRIC BENEFITS

VAPOR

A lightweight, high-gauge woven fabric with a four-way mechanical stretch. A solution that blocks out wind while remaining light and packable. High-filament yarns wick moisture away from the body to keep the wearer comfortable, dry and with zero cling to the body.

ACTIVE LINER

For extreme moisture control through hot conditions, 2XU's ACTIVE LINING is built with polyester filament yarns to keep the wearer dry and chafe-free.

BULK DYE LOGO EMBELLISHMENT OPTIONS

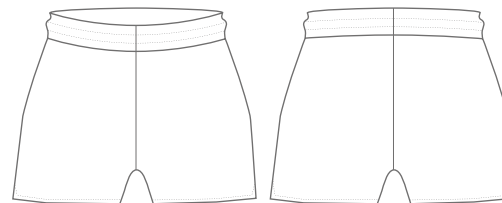

Levi is 188cm, 82kgs and wears a Medium

Garment pictured is sublimated, available bulk dye colours are black, navy and red.



WOMEN'S

PERFORM X CUSTOM RUN COLLECTION

WOMEN'S PERFORM X CUSTOM RUN COLLECTION

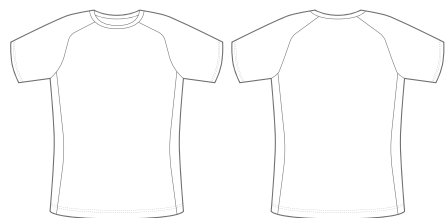

WX5703A 
Women's Perform X Run Tee

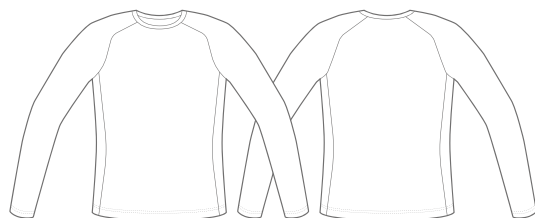

WX5707A 
Women's Perform X Longsleeve Run Top

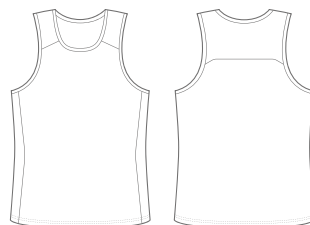

WX5705A 
Women's Perform X Run Tank

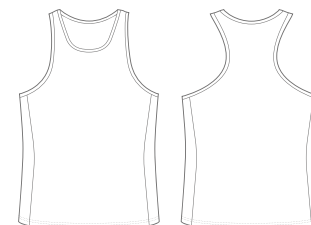

WX5701A 
Women's Perform X Racer Back Tank

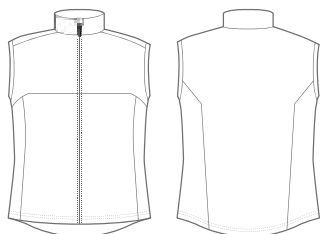

WX5715A
Women's Perform X Lightweight Run Vest

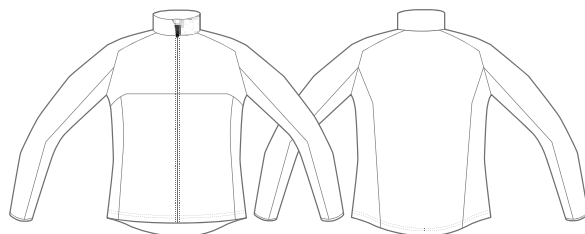

WX5713A
Women's Perform X Lightweight Run Jacket

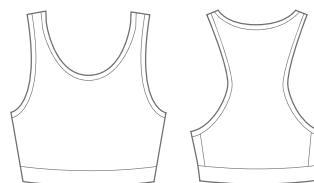

WX5711A
Women's Perform X Run Crop

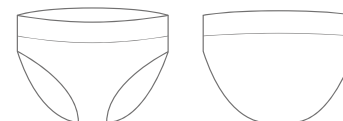

WX5724B
Women's Perform X Run Brief

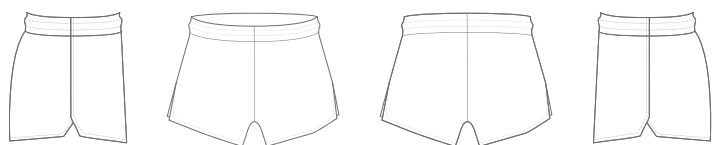

WX5709B
Women's Perform X 3-Inch Run Short

WOMEN'S PERFORM X RUN TEE

WX5703A

SIZE RANGE: 2XS - 4XL

SUBLIMATION or BULK DYE (black, red and navy)

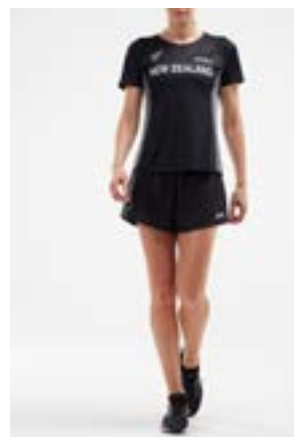

GARMENT FEATURES

01. Semi-fitted, active style tee.
02. Crew neckline with neck band and interior taping for comfort and durability.
03. Short sleeve with raglan design.
04. Chafe-free flatlock seam construction.
05. Engineered to meet all performance needs.

FABRIC BENEFITS

HI FIL

Utilising 2XU's breakthrough moisture management technology. Keeps you drier through high-filament yarns and cooler through our advanced knit structure.

Polygiene®

Odour control technology ensures you stay fresh and odour-free. Wear more, wash less and reduce your environmental footprint.

BULK DYE LOGO EMBELLISHMENT OPTIONS

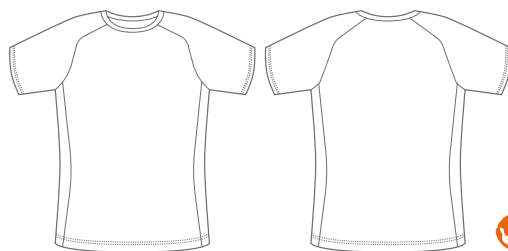

Emma is 180cm, 64kgs and wears a Small

Garment pictured is sublimated, available bulk dye colours are black, navy and red.

WOMEN'S PERFORM X LONGSLEEVE RUN TOP

WX5707A

SIZE RANGE: 2XS - 4XL

SUBLIMATION or BULK DYE (black, red and navy)

Emma is 180cm, 64kgs and wears a Small



GARMENT FEATURES

01. Semi-fitted, active style long sleeve top.
02. Crew neckline with neck band and interior taping for comfort and durability.
03. Long sleeve with raglan design.
04. Chafe-free flatlock seam construction.
05. Engineered to meet all performance needs.

FABRIC BENEFITS

HI FIL

Utilising 2XU's breakthrough moisture management technology. Keeps you drier through high-filament yarns and cooler through our advanced knit structure.

Polygiene®

Odour control technology ensures you stay fresh and odour-free. Wear more, wash less and reduce your environmental footprint.

BULK DYE LOGO EMBELLISHMENT OPTIONS

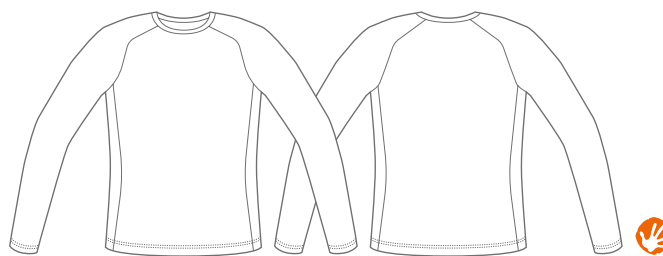

Garment pictured is sublimated, available bulk dye colours are black, navy and red.

WOMEN'S PERFORM X RUN TANK

WX5705A

SIZE RANGE: 2XS - 4XL

SUBLIMATION or BULK DYE (black, red and navy)

Emma is 180cm, 64kgs and wears a Small

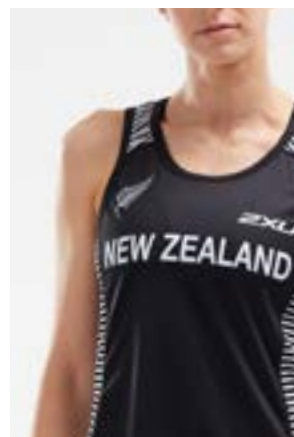
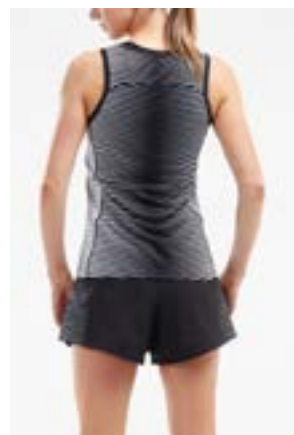

GARMENT FEATURES

01. Semi-fitted, active style tank.
02. Round neckline with neck bind.
03. Forward shoulder seam and back yoke panel.
04. Chafe-free flatlock seam construction.
05. Engineered to meet all performance needs.

FABRIC BENEFITS

HI FIL

Utilising 2XU's breakthrough moisture management technology. Keeps you drier through high-filament yarns and cooler through our advanced knit structure.

Polygiene®

Odour control technology ensures you stay fresh and odour-free. Wear more, wash less and reduce your environmental footprint.

BULK DYE LOGO EMBELLISHMENT OPTIONS

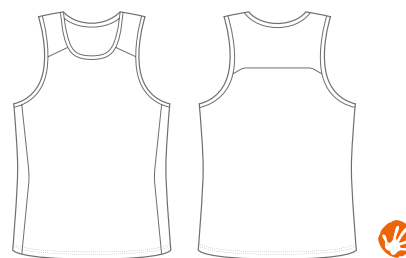

Garment pictured is sublimated, available bulk dye colours are black, navy and red.

WOMEN'S PERFORM X RACER BACK TANK

WX5701A

SIZE RANGE: 2XS - 4XL

SUBLIMATION or BULK DYE (black, red and navy)

Emma is 180cm, 64kgs and wears a Small

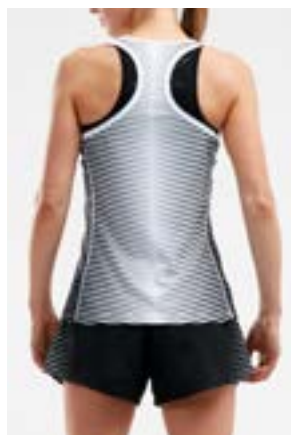

GARMENT FEATURES

01. Semi-fitted, racer back style tank.
02. Round neckline with neck bind.
03. Chafe-free flatlock seam construction.
04. Engineered to meet all performance needs.

FABRIC BENEFITS

HI FIL

Utilising 2XU's breakthrough moisture management technology. Keeps you drier through high-filament yarns and cooler through our advanced knit structure.

Polygiene®

Odour control technology ensures you stay fresh and odour-free. Wear more, wash less and reduce your environmental footprint.

BULK DYE LOGO EMBELLISHMENT OPTIONS

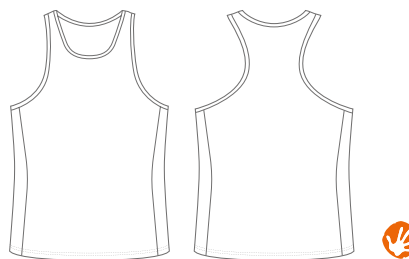

Garment pictured is sublimated, available bulk dye colours are black, navy and red.

WOMEN'S PERFORM X LIGHTWEIGHT RUN VEST

WX5715A

SIZE RANGE: 2XS - 4XL

SUBLIMATION or BULK DYE (black, red and navy)

Emma is 180cm, 64kgs and wears a Small



GARMENT FEATURES

01. Semi-fitted style with articulated back hem to provide extra coverage.
02. Stand-up collar for warmth and protection.
03. Full front zipper.
04. Sleeveless trans-seasonal style, ideal for layering.
05. Engineered to meet all performance needs.

FABRIC BENEFITS

VAPOR

A lightweight, high-gauge woven fabric with a four-way mechanical stretch. A solution that blocks out wind while remaining light and packable. High-filament yarns wick moisture away from the body to keep the wearer comfortable, dry and with zero cling to the body.

BULK DYE LOGO EMBELLISHMENT OPTIONS

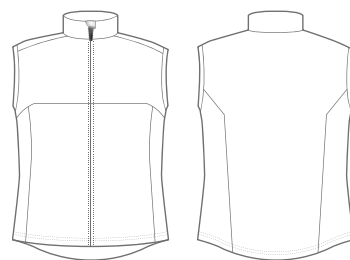

Garment pictured is sublimated, available bulk dye colours are black, navy and red.

WOMEN'S PERFORM X LIGHTWEIGHT RUN JACKET

WX5713A

SIZE RANGE: 2XS - 4XL

SUBLIMATION or BULK DYE (black, red and navy)

Emma is 180cm, 64kgs and wears a Small



GARMENT FEATURES

01. Semi-fitted style with articulated back hem to provide extra coverage.
02. Stand-up collar for warmth and protection.
03. Full front zipper.
04. Raglan sleeves for increased range of movement.
05. Engineered to meet all performance needs.

FABRIC BENEFITS

VAPOR

A lightweight, high-gauge woven fabric with a four-way mechanical stretch. A solution that blocks out wind while remaining light and packable. High-filament yarns wick moisture away from the body to keep the wearer comfortable, dry and with zero cling to the body.

BULK DYE LOGO EMBELLISHMENT OPTIONS

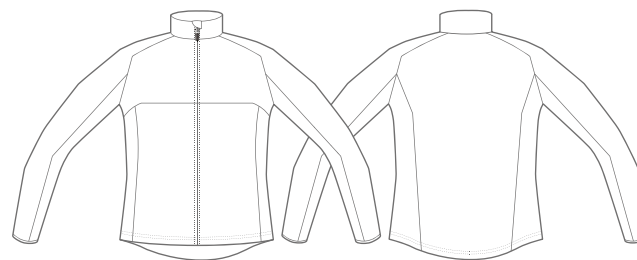

Garment pictured is sublimated, available bulk dye colours are black, navy and red.

WOMEN'S PERFORM X RUN CROP

WX5711A

SIZE RANGE: 2XS - 4XL

SUBLIMATION



GARMENT FEATURES

01. Fitted racer back style crop.
02. Full coverage.
03. Wide shoulder straps for support.
04. Supportive underbust elastic.
05. Engineered to meet all performance needs.

FABRIC BENEFITS

ICE X

Cooling technology that actively lowers skin temperature upon contact with skin. Engineered from high filament yarns, this impressive fabric keeps you cool in the heat and wicks moisture to keep you dry. Excellent stretch and recovery memory to move with the body.

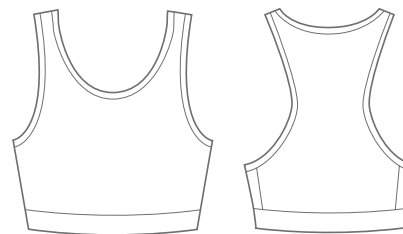

Emma is 180cm, 64kgs and wears a Small

WOMEN'S PERFORM X RUN BRIEF

WX5724B

SIZE RANGE: 2XS - 4XL

SUBLIMATION



GARMENT FEATURES

01. Performance brief design.
02. Full coverage.
03. 5cm width elasticated waistband.
04. Engineered to meet all performance needs.

FABRIC BENEFITS

ICE X

Cooling technology that actively lowers skin temperature upon contact with skin. Engineered from high filament yarns, this impressive fabric keeps you cool in the heat and wicks moisture to keep you dry. Excellent stretch and recovery memory to move with the body.

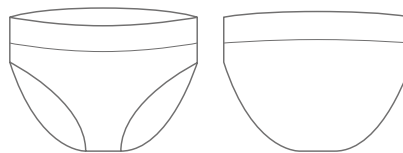

Emma is 180cm, 64kgs and wears a Small

WOMEN'S PERFORM X 3-INCH RUN SHORT

WX5709B

SIZE RANGE: 2XS - 4XL

SUBLIMATION or BULK DYE (black, red and navy)



GARMENT FEATURES

01. 3-inch inseam length.
02. Anatomically shaped crossover hem, raised and split at the side seams to offer a range of movement.
03. 4cm width elasticated waistband with an internal drawcord for a personalised and secure fit.
04. Internal stretch brief liner for comfort and coverage.
05. Internal key pocket for convenient storage.
06. Engineered to meet all performance needs.

FABRIC BENEFITS

VAPOR

A lightweight, high-gauge woven fabric with a four-way mechanical stretch. A solution that blocks out wind while remaining light and packable. High-filament yarns wick moisture away from the body to keep the wearer comfortable, dry and with zero cling to the body.

ACTIVE LINER

For extreme moisture control through hot conditions, 2XU's ACTIVE LINING is built with polyester filament yarns to keep the wearer dry and chafe-free.

BULK DYE LOGO EMBELLISHMENT OPTIONS

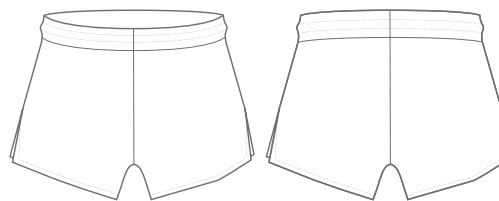

Emma is 180cm, 64kgs and wears a Small

Garment pictured is sublimated, available bulk dye colours are black, navy and red.



YOUTH

PERFORM X CUSTOM RUN COLLECTION

YOUTH PERFORM X CUSTOM RUN COLLECTION

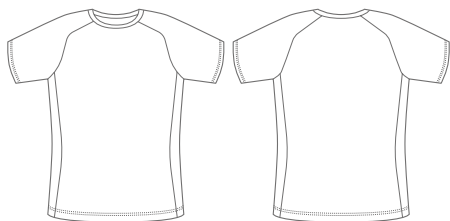

CX5721A 
Youth Perform X Run Tee

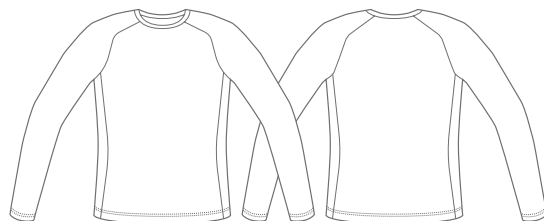

CX5719A 
Youth Perform X Longsleeve Run Top

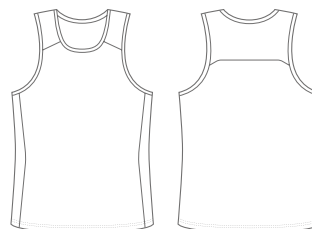

CX5720A 
Youth Perform X Run Tank

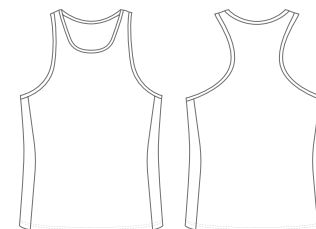

CX5718A 
Youth Perform X Racer Back Tank

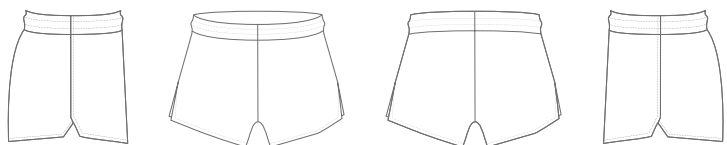

CX5722B
Youth Perform X Run Short

YOUTH PERFORM X RUN TEE

CX5721A

UNISEX SIZE RANGE: 6,8,10,12,14

SUBLIMATION or BULK DYE (black, red and navy)



GARMENT FEATURES

01. Semi-fitted, active style tee.
02. Crew neckline with neck band and interior taping for comfort and durability.
03. Short sleeve with raglan design.
04. Chafe-free flatlock seam construction.
05. Engineered to meet all performance needs.

FABRIC BENEFITS

HI FIL

Utilising 2XU's breakthrough moisture management technology. Keeps you drier through high-filament yarns and cooler through our advanced knit structure.

Polygiene®

Odour control technology ensures you stay fresh and odour-free. Wear more, wash less and reduce your environmental footprint.

BULK DYE LOGO EMBELLISHMENT OPTIONS

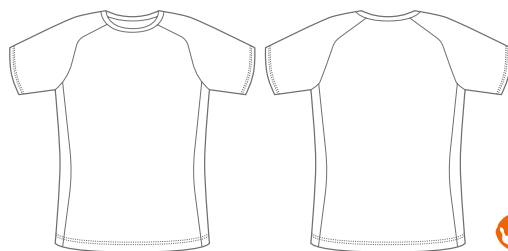

Garment pictured is sublimated, available bulk dye colours are black, navy and red.

YOUTH PERFORM X LONGSLEEVE RUN TOP

CX5719A

UNISEX SIZE RANGE: 6,8,10,12,14

SUBLIMATION or BULK DYE (black, red and navy)



GARMENT FEATURES

01. Semi-fitted, active style long sleeve top.
02. Crew neckline with neck band and interior taping for comfort and durability.
03. Long sleeve with raglan design.
04. Chafe-free flatlock seam construction.
05. Engineered to meet all performance needs.

FABRIC BENEFITS

HI FIL

Utilising 2XU's breakthrough moisture management technology. Keeps you drier through high-filament yarns and cooler through our advanced knit structure.

Polygiene®

Odour control technology ensures you stay fresh and odour-free. Wear more, wash less and reduce your environmental footprint.

BULK DYE LOGO EMBELLISHMENT OPTIONS

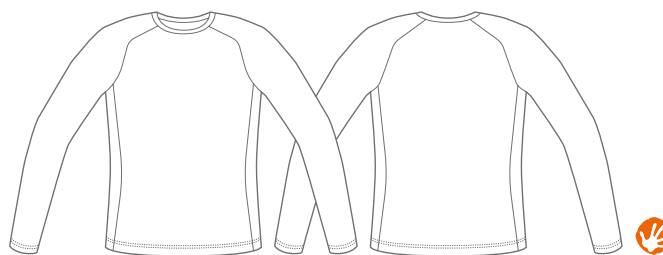

Garment pictured is sublimated, available bulk dye colours are black, navy and red.

YOUTH PERFORM X RUN TANK

CX5720A

UNISEX SIZE RANGE: 6,8,10,12,14

SUBLIMATION or BULK DYE (black, red and navy)



GARMENT FEATURES

01. Semi-fitted, active style tank.
02. Round neckline with neck bind.
03. Forward shoulder seam and back yoke panel.
04. Chafe-free flatlock seam construction.
05. Engineered to meet all performance needs.

FABRIC BENEFITS

HI FIL

Utilising ZXU's breakthrough moisture management technology. Keeps you drier through high-filament yarns and cooler through our advanced knit structure.

Polygiene®

Odour control technology ensures you stay fresh and odour-free. Wear more, wash less and reduce your environmental footprint.

BULK DYE LOGO EMBELLISHMENT OPTIONS

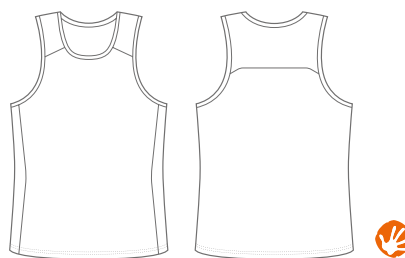

Garment pictured is sublimated, available bulk dye colours are black, navy and red.

YOUTH PERFORM X RACER BACK TANK

CX5718A

UNISEX SIZE RANGE: 6,8,10,12,14

SUBLIMATION or BULK DYE (black, red and navy)

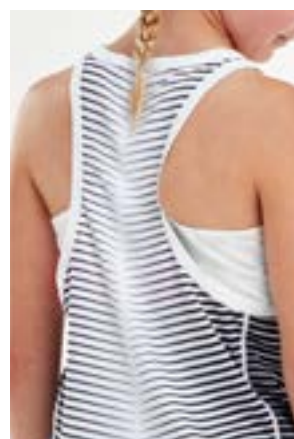

GARMENT FEATURES

01. Semi-fitted, racer back style tank.
02. Round neckline with neck bind.
03. Chafe-free flatlock seam construction.
04. Engineered to meet all performance needs.

FABRIC BENEFITS

HI FIL

Utilising 2XU's breakthrough moisture management technology. Keeps you drier through high-filament yarns and cooler through our advanced knit structure.

Polygiene®

Odour control technology ensures you stay fresh and odour-free. Wear more, wash less and reduce your environmental footprint.

BULK DYE LOGO EMBELLISHMENT OPTIONS

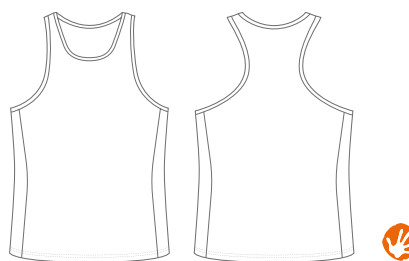

Garment pictured is sublimated, available bulk dye colours are black, navy and red.

YOUTH PERFORM X RUN SHORT

CX5722B

UNISEX SIZE RANGE: 6,8,10,12,14

SUBLIMATION or BULK DYE (black, red and navy)

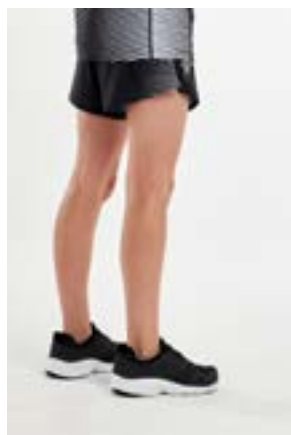

GARMENT FEATURES

01. Anatomically shaped crossover hem, raised and split at the side seams to offer a range of movement.
02. 4cm width elasticated waistband with an internal drawcord for a personalised and secure fit.
03. Internal stretch brief liner for comfort and coverage.
04. Internal key pocket for convenient storage.
05. Engineered to meet all performance needs.

FABRIC BENEFITS

VAPOR

A lightweight, high-gauge woven fabric with a four-way mechanical stretch. A solution that blocks out wind while remaining light and packable. High-filament yarns wick moisture away from the body to keep the wearer comfortable, dry and with zero cling to the body.

ACTIVE LINER

For extreme moisture control through hot conditions, 2XU's ACTIVE LINING is built with polyester filament yarns to keep the wearer dry and chafe-free.

BULK DYE LOGO EMBELLISHMENT OPTIONS

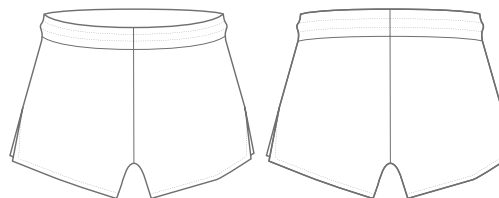

Garment pictured is sublimated, available bulk dye colours are black, navy and red.



SIZE GUIDE

PERFORM X CUSTOM CASUAL COLLECTION

PERFORM X CUSTOM CASUAL COLLECTION SIZING INFORMATION - MEN'S

MEN'S SIZING

MEASUREMENT (circumference)		2XS	XS	S	M	L	XL	2XL	3XL	4XL	5XL
Chest	cm	83-87	88-92	93- 97	98 -102	103-107	108-112	113-117	118-122	123-127	128-132
	inches	32 ^{5/8} - 34 ^{1/4}	32 ^{5/8} - 34 ^{1/4}	36 ^{5/8} - 38 ^{1/4}	38 ^{5/8} - 40 ^{1/8}	40 ^{1/2} - 42 ^{1/8}	42 ^{1/2} - 44 ^{1/8}	44 ^{1/2} - 46	46 ^{1/2} - 48	48 ^{3/8} - 50	50 ^{3/8} - 52
Waist	cm	65- 69	70-74	75-79	80-84	85-89	90-94	95-99	100-104	105-109	110-114
	inches	25 ^{1/2} - 27 ^{1/8}	27 ^{1/2} - 29 ^{1/8}	29 ^{1/2} - 31 ^{1/8}	31 ^{1/2} - 33	33 ^{1/2} - 35	35 ^{3/8} - 37	37 ^{3/8} - 39	39 ^{3/8} - 41	41 ^{3/8} - 42 ^{7/8}	43 ^{3/8} - 44 ^{7/8}



Levi is 188cm, 82kgs and wears a Medium

PERFORM X CUSTOM CASUAL COLLECTION SIZING INFORMATION - WOMEN'S

WOMEN'S SIZING

MEASUREMENT (circumference)		2XS	XS	S	M	L	XL	2XL	3XL	4XL
Chest	cm	78-82	83-87	88-92	93 - 97	98 -102	103-107	108-112	113-117	118-122
	inches	30 ³ / ₄ - 32 ¹ / ₄	32 ⁵ / ₈ - 34 ¹ / ₄	34 ⁵ / ₄ - 36 ¹ / ₄	36 ⁵ / ₈ - 38 ¹ / ₄	38 ⁵ / ₈ - 40 ¹ / ₄	40 ¹ / ₂ - 42 ¹ / ₈	42 ¹ / ₂ - 44 ¹ / ₈	44 ¹ / ₂ - 46	46 ¹ / ₂ - 48
Waist	cm	58-62	63-67	68-72	73-77	78-82	83-87	88-92	93-97	98-102
	inches	22 ³ / ₄ - 24 ³ / ₈	24 ³ / ₄ - 26 ³ / ₈	26 ³ / ₄ - 28 ³ / ₈	28 ³ / ₄ - 30 ³ / ₈	30 ³ / ₄ - 32 ¹ / ₄	32 ³ / ₄ - 34 ¹ / ₄	34 ⁵ / ₈ - 36 ¹ / ₄	36 ⁵ / ₈ - 38 ¹ / ₄	38 ⁵ / ₈ - 40 ¹ / ₈
Hip	cm	86-90	91-95	96-100	101-105	106-110	111-115	116-120	121-125	126-130
	inches	33 ⁷ / ₈ - 35 ¹ / ₂	35 ⁷ / ₈ - 37 ³ / ₈	37 ³ / ₄ - 39 ³ / ₈	39 ³ / ₄ - 41 ³ / ₈	41 ³ / ₄ - 43 ³ / ₈	43 ³ / ₄ - 45 ¹ / ₄	45 ⁵ / ₈ - 47 ¹ / ₄	47 ⁵ / ₈ - 49 ¹ / ₄	49 ⁵ / ₈ - 51 ¹ / ₄



Emma is 180cm, 64kgs and wears a Small

PERFORM X CUSTOM CASUAL COLLECTION SIZING INFORMATION - YOUTH

YOUTH UNISEX SIZING

MEASUREMENT (circumference)		6	8	10	12	14
Chest	cm	58-62	63-68	69-74	75-77	79-81
	inches	22 ^{3/4} -24 ^{1/2}	24 ^{3/4} -26 ^{3/4}	27 ^{1/8} -29 ^{1/8}	29 ^{1/2} -30 ^{1/4}	31-32
Waist	cm	56-58	59-62	63-66	67-69	70-74
	inches	22-22 ^{3/4}	23 ^{1/4} -24 ^{1/2}	24 ^{3/4} -26	26 ^{3/8} -27 ^{1/4}	27 ^{1/2} -29



2XU
C U S T O M



CUSTOM TRIATHLON RANGE



CUSTOM TRI FABRIC TECHNICAL INFORMATION

Our Custom Tri collection is specifically designed and engineered for the rigours of triathlon and is built for all-round performance.



KINETIC COOL

Developed with cutting-edge hydrophobic polyester, KINETIC COOL minimises water retention and hydrodynamic drag, improves water repulsion by up to 50%, and accelerates drying. Complete with a four-way stretch system for outstanding flexibility.



PWX COMPRESSION

Premium compression fabric engineered to offer optimal POWER, WEIGHT + FLEXIBILITY in perfect equilibrium.



SENSOR MESH

Mesh structure for more airflow and soft hand feel for comfort. SENSOR MESH has a high LYCRA® content for enhanced flexibility with the body. With high filament polyester yarn for impressive moisture management, this fabric keeps the wearer dry and comfortable.



KINETIC SPEED

Utilises swiss air turbulent technology for improved aerodynamics and 2XU's powerful 70D/CK compression fabric for greater endurance and power.

Engineered with high-quality LYCRA® fibre to enhance garment shape retention and fit. A revolutionary fabric unmatched in speed and compression performance.

CUSTOM TRI BULK DYE OPTIONS

Choose from these five bulk dye fabric colours to best customise your tri kit.

BLACK

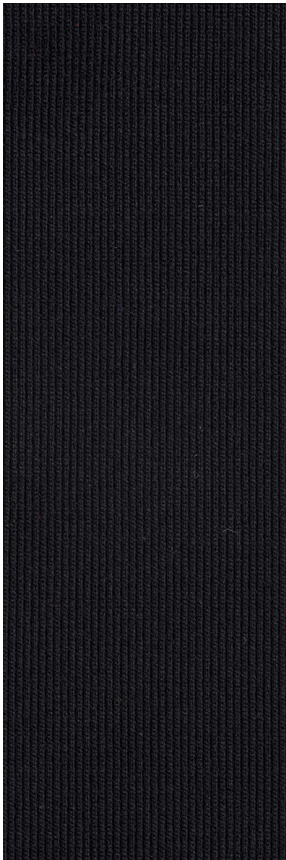

GUNMETAL GREY

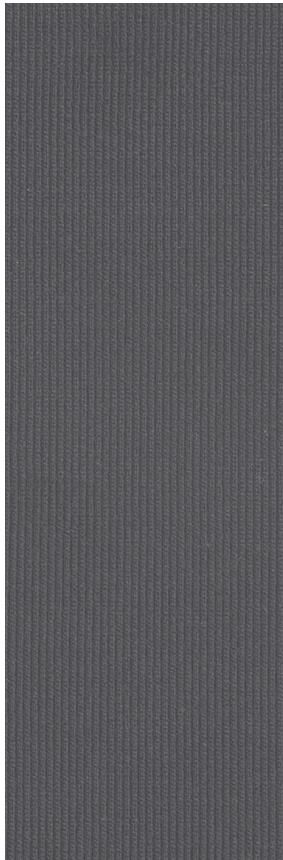

NAVY 282C



REFLEX BLUE C

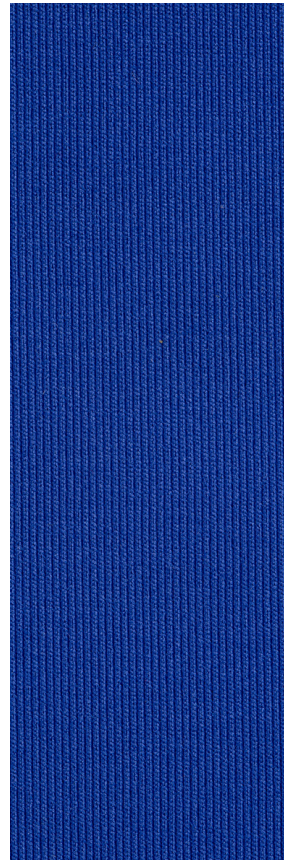

RED 186 C

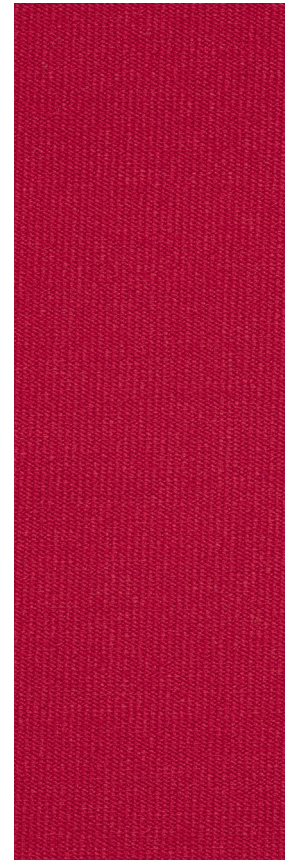

*Enquire with your 2XU Custom representative for additional customisation options.



AERO TRI-X

CUSTOM TRI SUITS

DELIVERING UNRIVALED PERFORMANCE FOR SWIM, BIKE AND RUN DEMANDS, THE 2XU AERO TRI COLLECTION REPRESENTS BEST IN CLASS TRIATHLON ENGINEERING.

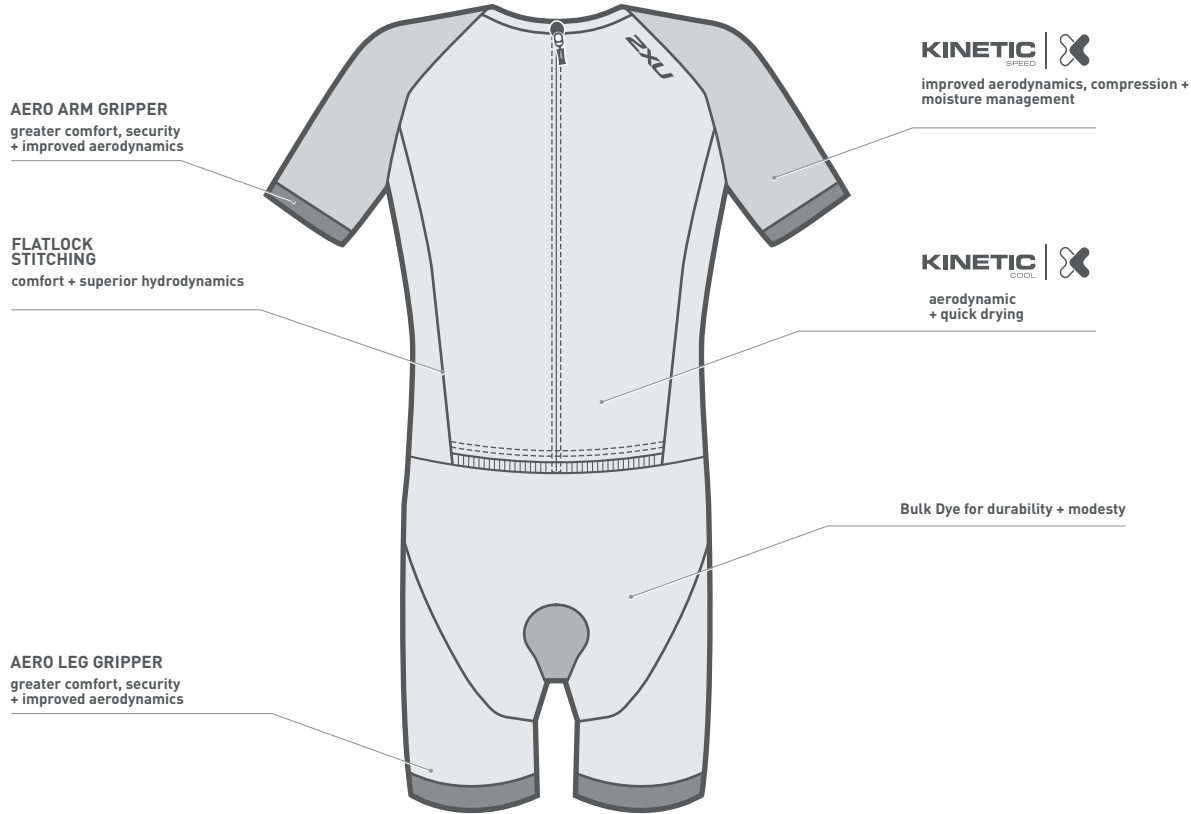

MEN'S AERO TRI-X SKIN SUIT

MX3259D

BULK DYE/SUBLIMATION

SIZE RANGE: 2XS - 4XL



GARMENT FEATURES

01. Unique open front waist skinsuit design
02. Aero arm + leg grippers
03. 3 rear pockets

FABRIC BENEFITS

KINETIC  KINETIC 

LDCHAMOIS

Quick drying long course triathlon chamois fused onto high density, hydrophobic foam base to manage moisture and deliver comfort to go the distance.

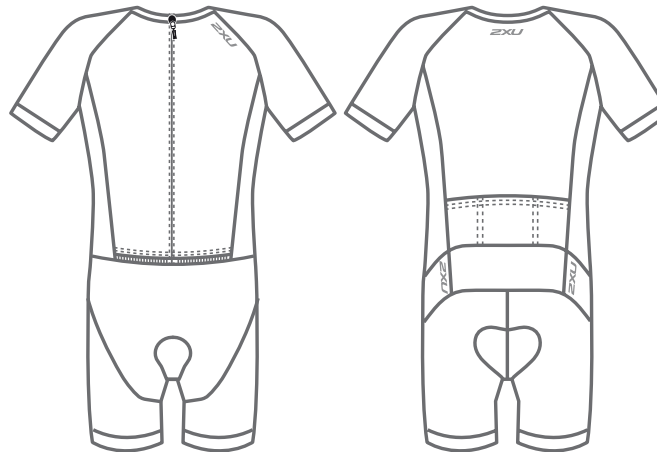

WOMEN'S AERO TRI-X SKIN SUIT

WX3260D

BULK DYE/SUBLIMATION

SIZE RANGE: 2XS - 2XL



GARMENT FEATURES

01. Aero arm + leg grippers
02. 3 rear pockets

FABRIC BENEFITS

KINETIC |  KINETIC | 

LDCHAMOIS

Quick drying long course triathlon chamois fused onto high density, hydrophobic foam base to manage moisture and deliver comfort to go the distance.

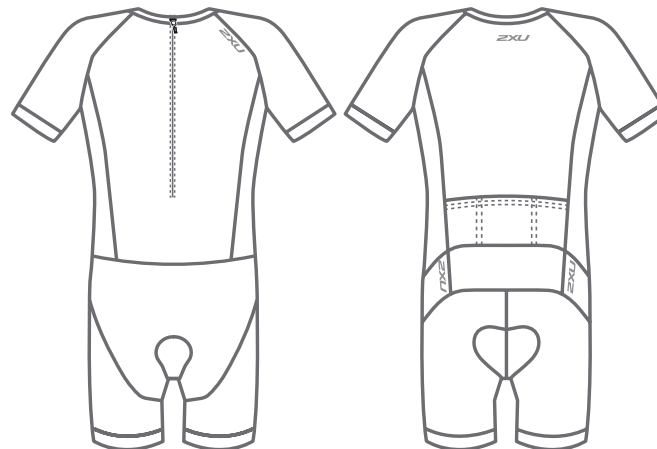

MEN'S AND WOMEN'S SLEEVELESS AERO TRI SUIT

MX3390D/WX3391D
BULK DYE/SUBLIMATION
SIZE RANGE: 2XS - 4XL



GARMENT FEATURES

01. Front zipper
02. Sleeveless design
03. 2 rear pockets

FABRIC BENEFITS

KINETIC |  **KINETIC** | 

LDCHAMOIS

Quick drying long course triathlon chamois fused onto high density, hydrophobic foam base to manage moisture and deliver comfort to go the distance.

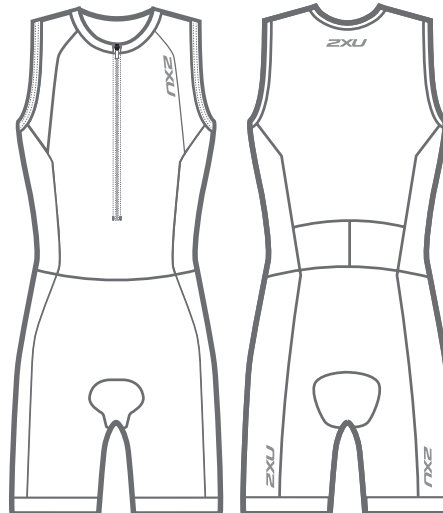



LONG DISTANCE

CUSTOM TRI SUITS, SINGLETs AND SHORTS

EXPERTLY ENGINEERED FOR LONG COURSE RACING.

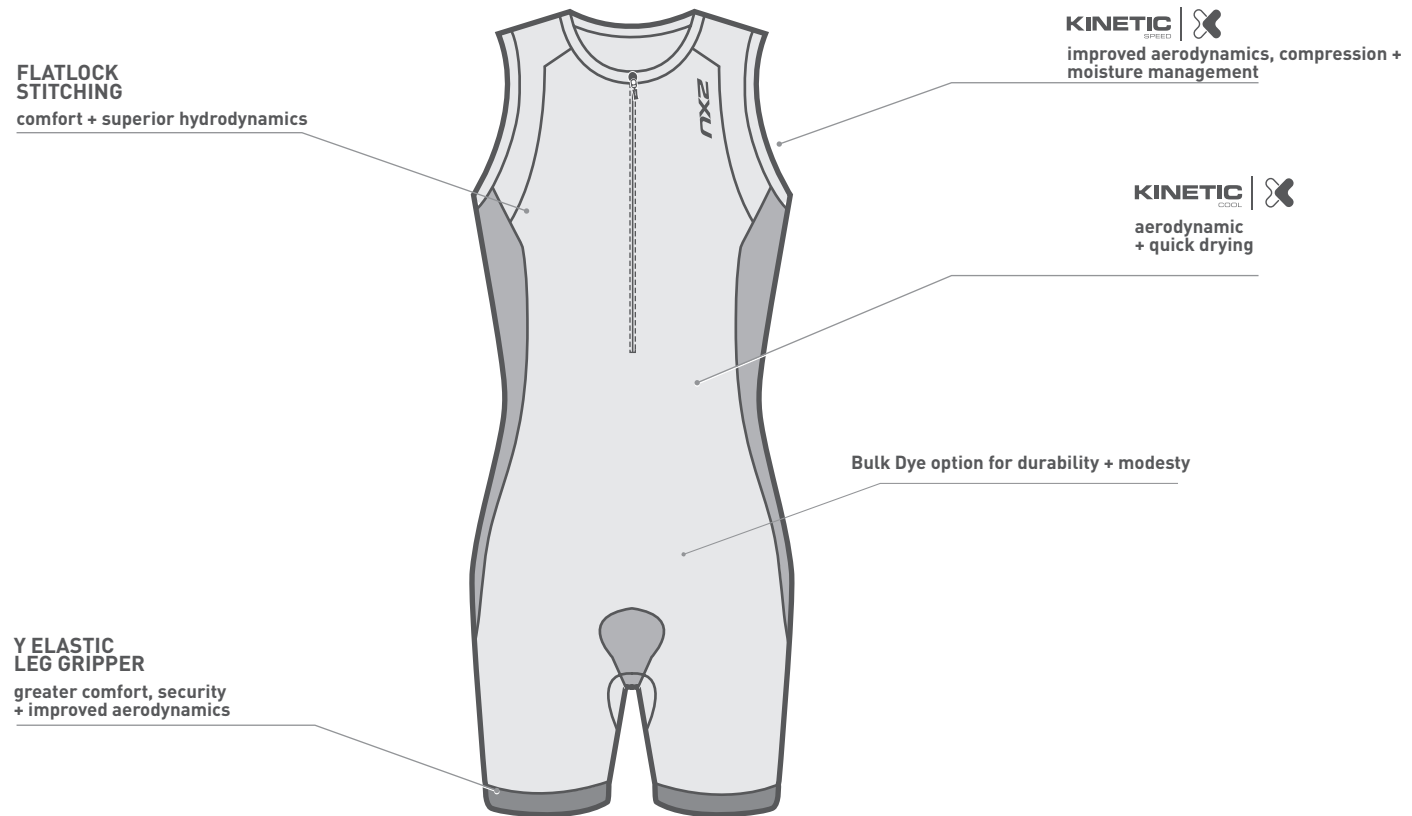

MEN'S LONG DISTANCE TRI SUIT

MX0057D

BULK DYE/SUBLIMATION

SIZE RANGE: 2XS - 4XL



GARMENT FEATURES

01. 3/4 front semi-lock zipper
02. 2 rear pockets
03. Kinetic cool for thermo-regulation + 4 way stretch
04. 70D Kinetic Speed fabric for supreme aerodynamics
05. Y Elastic leg gripper
06. 2 rear pockets

FABRIC BENEFITS

KINETIC  KINETIC 

LDCHAMOIS

Quick drying long course triathlon chamois fused onto high density, hydrophobic foam base to manage moisture and deliver comfort to go the distance.

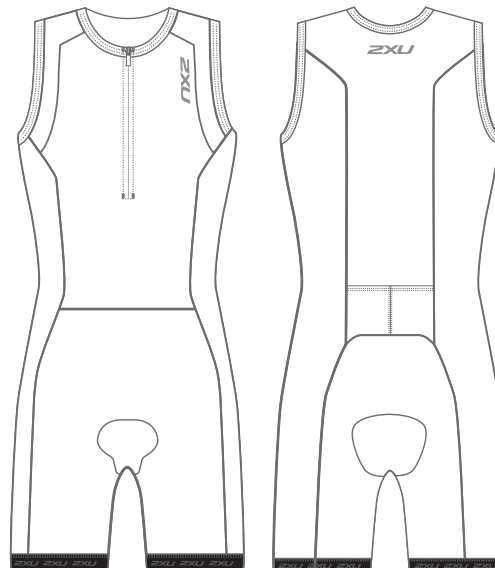

WOMEN'S LONG DISTANCE TRI SUIT

WX0058D
BULK DYE/SUBLIMATION
SIZE RANGE: 2XS - 2XL



GARMENT FEATURES

01. 3/4 front semi-lock zipper
02. 2 rear pockets
03. Kinetic cool for thermo-regulation + 4 way stretch
04. 70D Kinetic Speed fabric for supreme aerodynamics
05. Y Elastic leg gripper
06. 2 Rear pockets

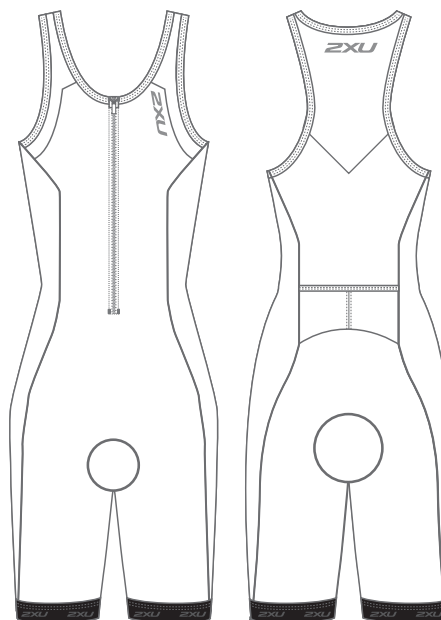

FABRIC BENEFITS

KINETIC  KINETIC 

SENSOR MESH 

LDCHAMOIS

Quick drying long course triathlon chamoisfused onto high density, hydrophobic foam base to manage moisture and deliver comfort to go the distance. Sensor mesh rear panelling for superior ventilation.

MEN'S LONG DISTANCE TRI SINGLET

MX0054A SUBLIMATION

SIZE RANGE: 2XS - 4XL



GARMENT FEATURES

01. 3/4 front semi-lock zipper
02. 3 rear pockets
03. Kinetic cool for thermo-regulation + 4 way stretch
04. 70D Kinetic Speed fabric for supreme aerodynamics
05. Flatlock seams to prevent chaffing

FABRIC BENEFITS



WOMEN'S LONG DISTANCE TRI SINGLET

WX0060A
SUBLIMATION

SIZE RANGE: 2XS - 2XL



GARMENT FEATURES

01. 3/4 front semi-lock zipper
02. 2 rear pockets
03. Kinetic cool for thermo-regulation + 4 way stretch
04. 70D Kinetic Speed fabric for supreme aerodynamics
05. Flatlock seams to prevent chaffing
06. Sensor Mesh back panel for breathability

FABRIC BENEFITS

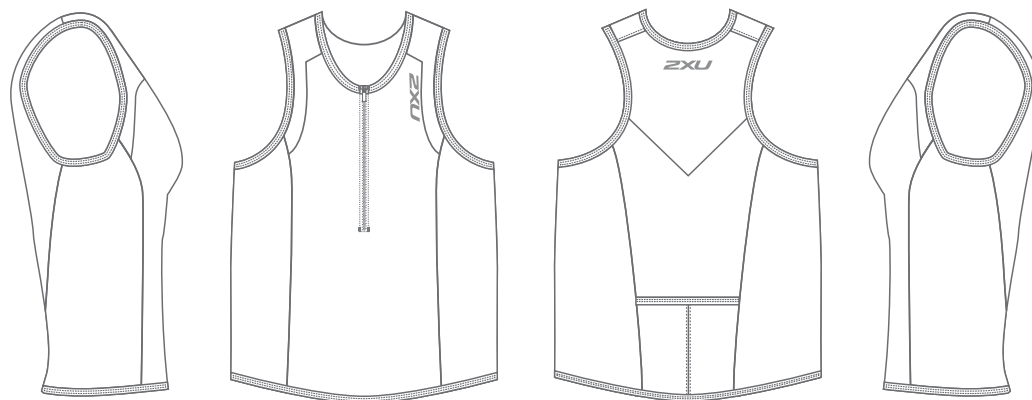

MEN'S LONG DISTANCE TRI SHORT

MX0055B

BULK DYE/SUBLIMATION

SIZE RANGE: 2XS - 4XL



GARMENT FEATURES

01. 2 rear pockets
02. Kinetic cool for thermo-regulation + 4 way stretch
03. 70D Kinetic Speed fabric for supreme aerodynamics
04. Flatlock seams to prevent chaffing
05. Y Elastic leg gripper

FABRIC BENEFITS

KINETIC |  KINETIC | 

LDCHAMOIS

Quick drying long course triathlon chamois fused onto high density, hydrophobic foam base to manage moisture and deliver comfort to go the distance.

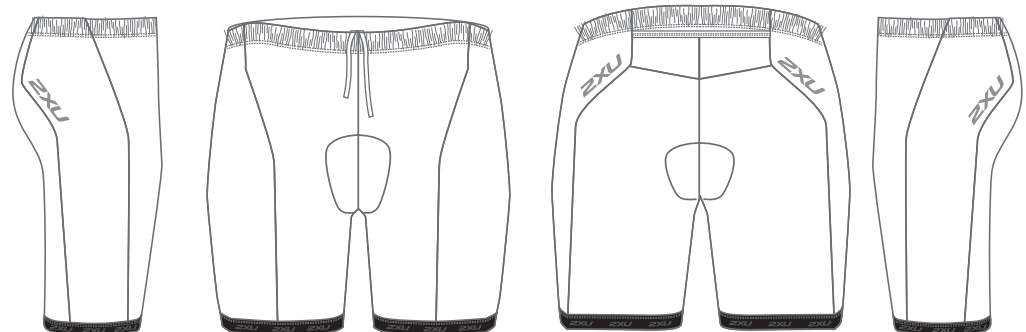

WOMEN'S LONG DISTANCE TRI SHORT

WX0059B

BULK DYE/SUBLIMATION

SIZE RANGE: 2XS - 2XL



GARMENT FEATURES

01. 2 rear pockets
02. Kinetic cool for thermo-regulation + 4 way stretch
03. 70D Kinetic Speed fabric for supreme aerodynamics
04. Flatlock seams to prevent chaffing
05. Y Elastic leg gripper

FABRIC BENEFITS

KINETIC |  KINETIC | 

LDCHAMOIS

Quick drying long course triathlon chamois fused onto high density, hydrophobic foam base to manage moisture and deliver comfort to go the distance.

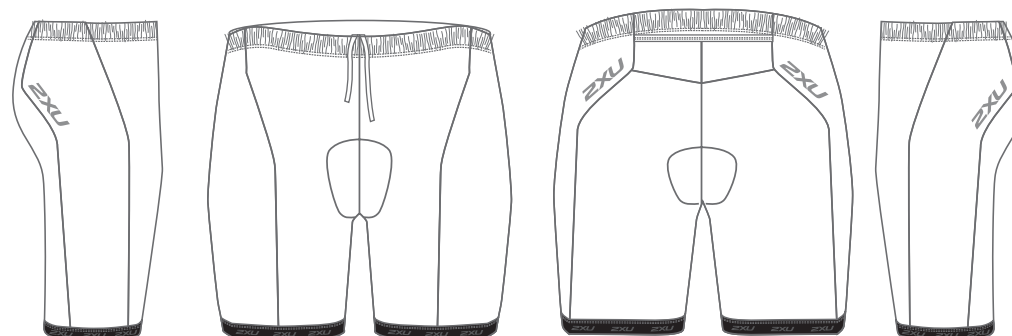

WOMEN'S LONG DISTANCE 6" TRI SHORT

WX3392B
BULK DYE/SUBLIMATION

SIZE RANGE: 2XS - 2XL



GARMENT FEATURES

01. 2 rear pockets
02. Kinetic cool for thermo-regulation + 4 way stretch
03. 70D Kinetic Speed fabric for supreme aerodynamics
04. Flatlock seams to prevent chaffing
05. Y Elastic leg gripper

FABRIC BENEFITS



LDCHAMOIS

Quick drying long course triathlon chamois fused onto high density, hydrophobic foam base to manage moisture and deliver comfort to go the distance.

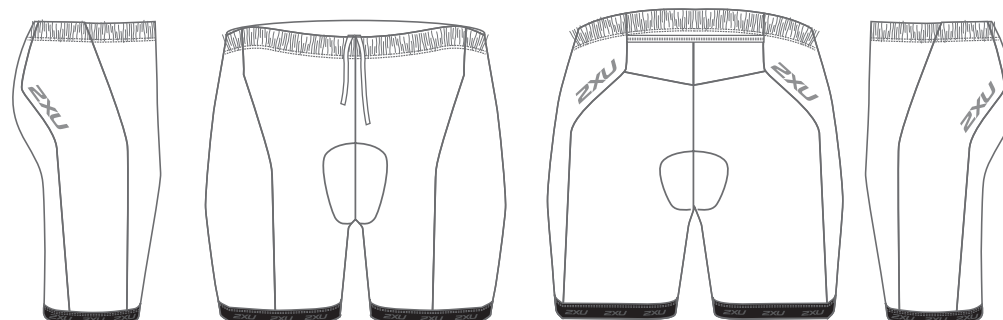



ACTIVE

CUSTOM TRI SUITS, SINGLETs AND SHORTS

FEATURING PREMIUM FABRICS, TRIMS AND BENEFITS TYPICALLY EXPECTED IN ELITE STYLES, THE ACTIVE COLLECTION IS THE MOST COMPETITIVE PROPOSITION ON THE CIRCUIT.

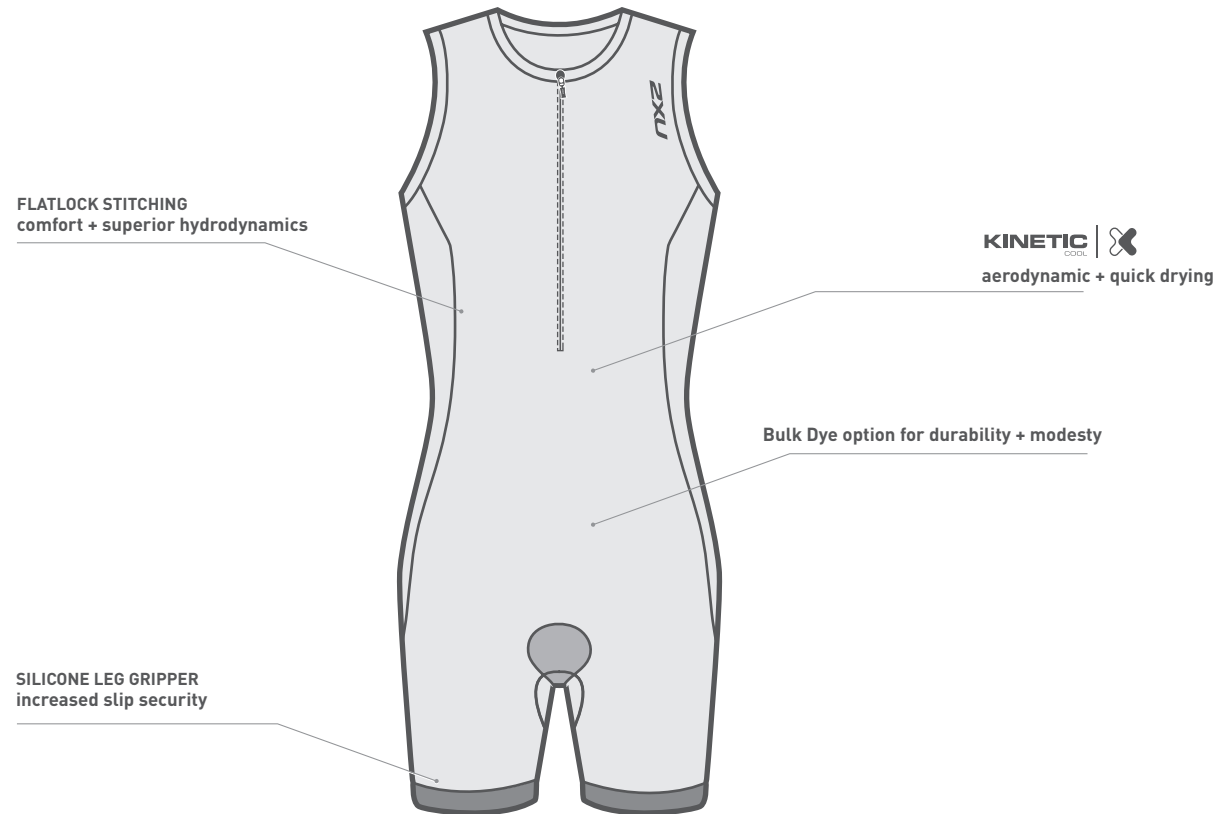

MEN'S ACTIVE TRI SUIT

MX0013D

BULK DYE/SUBLIMATION

SIZE RANGE: 2XS - 4XL



GARMENT FEATURES

01. 3/4 front or rear semi-lock zipper
02. Kinetic cool for thermo-regulation + 4 way stretch
03. 70D Kinetic Speed fabric for supreme aerodynamics
04. Flatlock seams to prevent chaffing
05. Silicone leg gripper

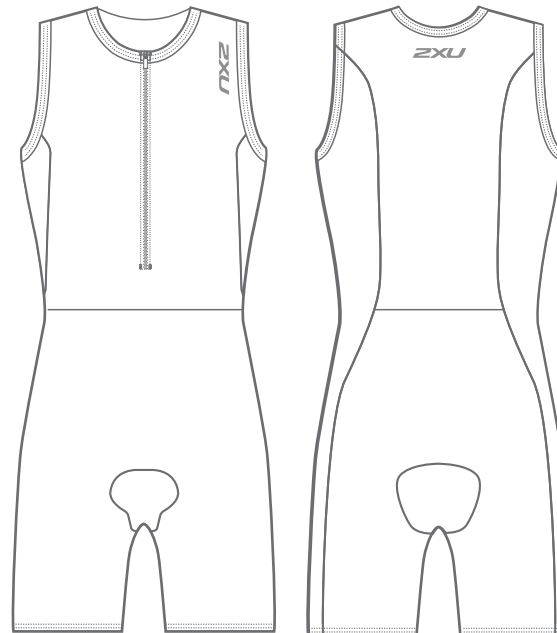

FABRIC BENEFITS



SBR FLEECE CHAMOIS

Using a micro-filament polyester yarn, 2XU has developed a fleece with enough padding for the bike while remaining discreet for the swim and run. Using polyester yarns with hydrophobic properties, this fabric delivers critical antibacterial protection and will remain dry through all three disciplines.

WOMEN'S ACTIVE TRI SUIT

WX0012D
BULK DYE/SUBLIMATION
SIZE RANGE: 2XS - 2XL



GARMENT FEATURES

01. 3/4 front or rear semi-lock zipper
02. Kinetic cool for thermo-regulation + 4 way stretch
03. 70D Kinetic Speed fabric for supreme aerodynamics
04. Flatlock seams to prevent chaffing
05. Silicone leg gripper

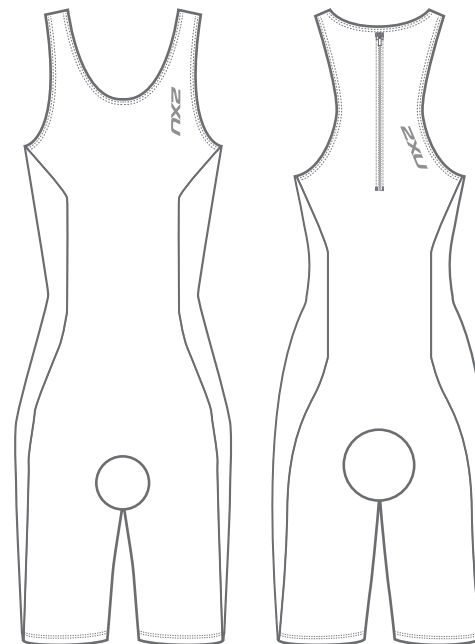

FABRIC BENEFITS



SBR FLEECE CHAMOIS

Using a micro-filament polyester yarn, 2XU has developed a fleece with enough padding for the bike while remaining discreet for the swim and run. Using polyester yarns with hydrophobic properties, this fabric delivers critical antibacterial protection and will remain dry through all three disciplines.

MEN'S ACTIVE TRI SINGLET

MX0011A
SUBLIMATION

SIZE RANGE: 2XS - 4XL



GARMENT FEATURES

01. 3/4 front or rear semi-lock zipper
02. Kinetic cool for thermo-regulation + 4 way stretch
03. 70D Kinetic Speed fabric for supreme aerodynamics
04. Flatlock seams to prevent chaffing
05. 1 rear pocket

FABRIC BENEFITS



WOMEN'S ACTIVE TRI SINGLET

WX0010A
SUBLIMATION

SIZE RANGE: 2XS - 4XL



GARMENT FEATURES

01. Kinetic cool for thermo-regulation + 4 way stretch
02. 70D Kinetic Speed fabric for supreme aerodynamics
03. Flatlock seams to prevent chaffing
04. 2 rear pockets

FABRIC BENEFITS

KINETIC |  KINETIC | 



MEN'S ACTIVE TRI SHORT

MX0009B

BULK DYE/SUBLIMATION

SIZE RANGE: 2XS - 4XL



GARMENT FEATURES

01. Kinetic cool for thermo-regulation + 4 way stretch
02. Silicone leg gripper
03. Flatlock seams to prevent chaffing
04. SBR Fleece chamois

FABRIC BENEFITS

KINETIC |  KINETIC | 

SBR FLEECE CHAMOIS

Using a micro-filament polyester yarn, 2XU has developed a fleece with enough padding for the bike while remaining discreet for the swim and run. Using polyester yarns with hydrophobic properties, this fabric delivers critical antibacterial protection and will remain dry through all three disciplines.

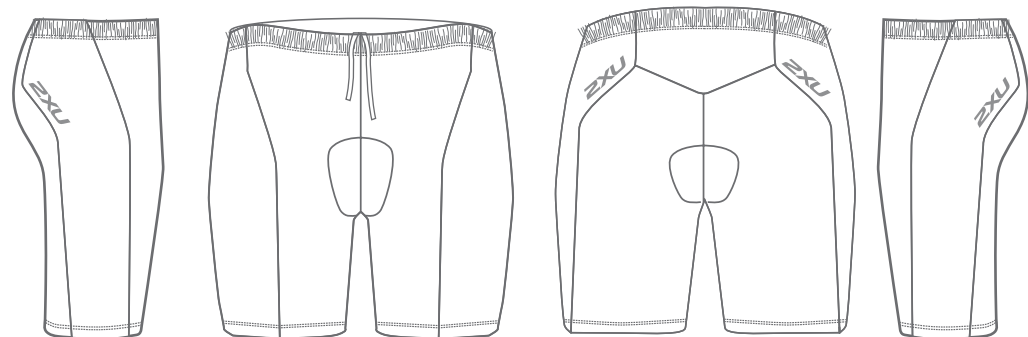

WOMEN'S ACTIVE TRI SHORT

WX0008B

BULK DYE/SUBLIMATION

SIZE RANGE: 2XS - 2XL



GARMENT FEATURES

01. Kinetic cool for thermo-regulation + 4 way stretch
02. Silicone leg gripper
03. Flatlock seams to prevent chaffing
04. SBR Fleece chamois
05. 70D Kinetic Speed fabric for supreme aerodynamics

FABRIC BENEFITS



SBR FLEECE CHAMOIS

Using a micro-filament polyester yarn, 2XU has developed a fleece with enough padding for the bike while remaining discreet for the swim and run. Using polyester yarns with hydrophobic properties, this fabric delivers critical antibacterial protection and will remain dry through all three disciplines.

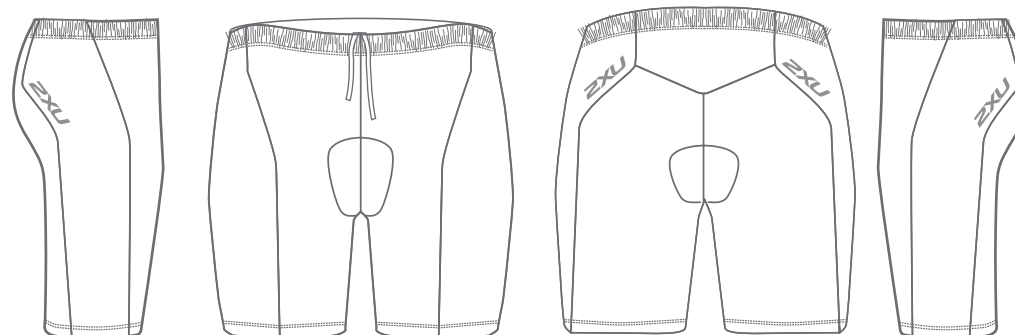

WOMEN'S ACTIVE TRI CROP

WX0026A

SUBLIMATION

SIZE RANGE: 2XS - 2XL



GARMENT FEATURES

01. Kinetic cool for thermo-regulation + 4 way stretch
02. Flatlock seams to prevent chaffing

FABRIC BENEFITS

KINETIC 



WOMEN'S ACTIVE HIPSTER SHORT

WX0027B

BULK DYE/SUBLIMATION

SIZE RANGE: 2XS - 2XL



GARMENT FEATURES

01. Kinetic cool for thermo-regulation + 4 way stretch
02. Silicone leg gripper
03. Flatlock seams to prevent chaffing
04. SBR Fleece chamois
05. 70D Kinetic Speed fabric for supreme aerodynamics

FABRIC BENEFITS



SBR FLEECE CHAMOIS

Using a micro-filament polyester yarn, 2XU has developed a fleece with enough padding for the bike while remaining discreet for the swim and run. Using polyester yarns with hydrophobic properties, this fabric delivers critical antibacterial protection and will remain dry through all three disciplines.

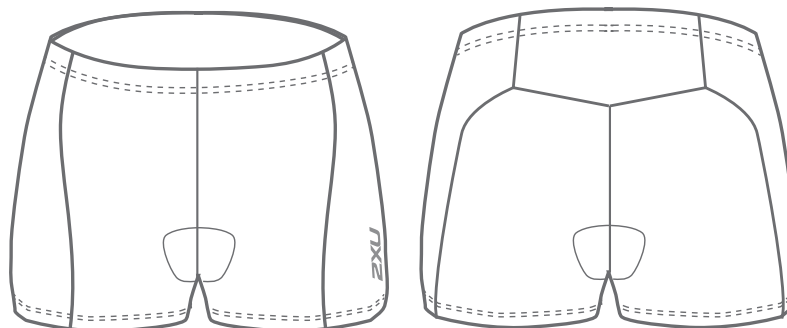

WOMEN'S ACTIVE SWIM BACK

WX3258D

BULK DYE/SUBLIMATION

SIZE RANGE: 2XS - 2XL



GARMENT FEATURES

01. Elasticised binding for ultimate comfort + fit
02. Silicone leg gripper

FABRIC BENEFITS



SBR FLEECE CHAMOIS

Using a micro-filament polyester yarn, 2XU has developed a fleece with enough padding for the bike while remaining discreet for the swim and run. Using polyester yarns with hydrophobic properties, this fabric delivers critical antibacterial protection and will remain dry through all three disciplines.

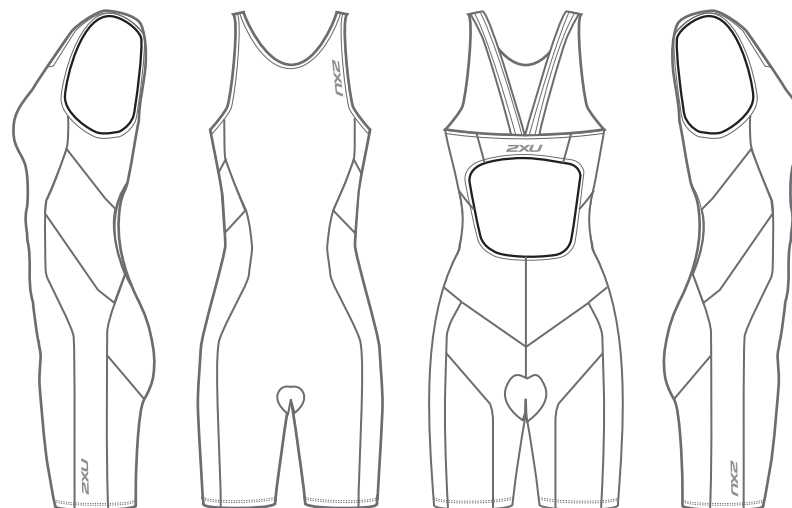

WOMEN'S ACTIVE TRI SWIM SUIT

WX3262D

SUBLIMATION

SIZE RANGE: 2XS - 2XL



GARMENT FEATURES

01. Elasticised binding for ultimate comfort + fit
02. Kinetic cool for thermo-regulation + 4-way stretch

FABRIC BENEFITS

KINETIC 



YOUTH ACTIVE TRI SUIT

CX3363D

BULK DYE/SUBLIMATION

SIZE RANGE: 8-14



GARMENT FEATURES

01. Silicone leg gripper
02. Rear semi-lock zip
03. 30cm rear zip

FABRIC BENEFITS



SBR FLEECE CHAMOIS

Using a micro-filament polyester yarn, 2XU has developed a fleece with enough padding for the bike while remaining discreet for the swim and run. Using polyester yarns with hydrophobic properties, this fabric delivers critical antibacterial protection and will remain dry through all three disciplines.

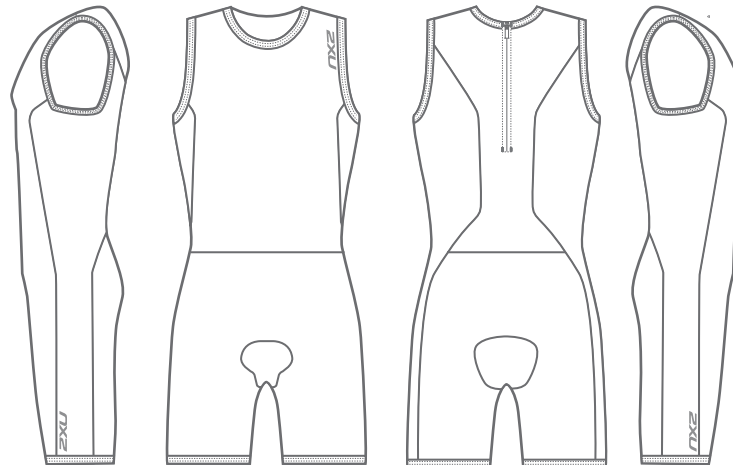



H1-2021

ENGINEERED STORY

KEY LOOKS

WOMEN'S TRAINING

OAT/OAT

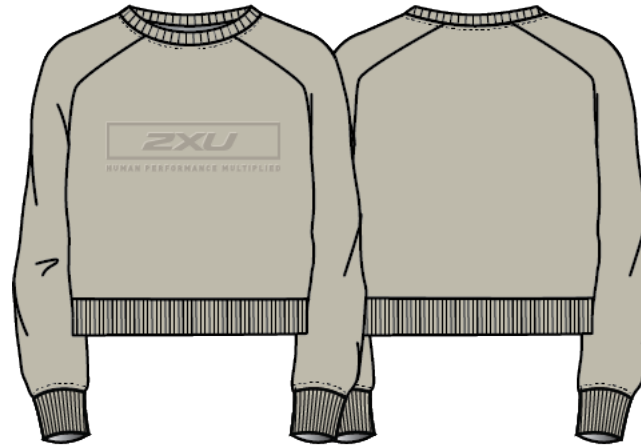

WR6458a. FORM CROP CREW

WHT/BLK



WR6466a. FORM CROP TEE

BLK/SRF



UQ6581f. MULTIPLY CAP

OAT/BLK

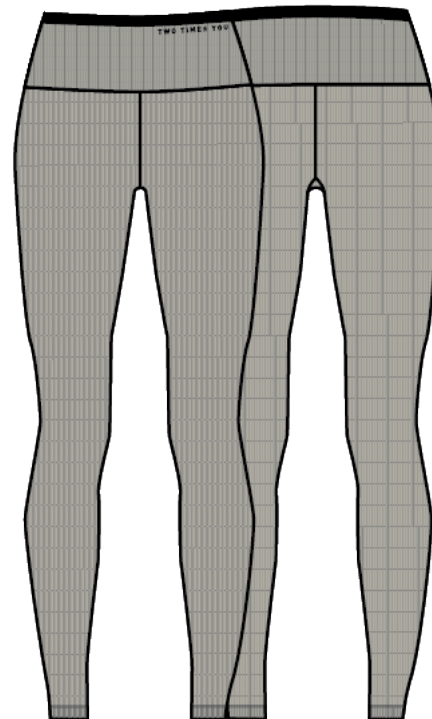

WR6464b. ENGINEERED TIGHTS

OAT/BLK

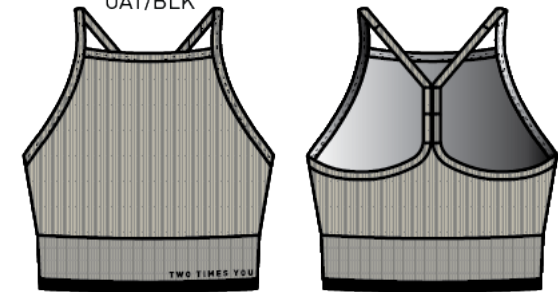

WR6462a. ENGINEERED LONGLINE CROP

OAT/BLK

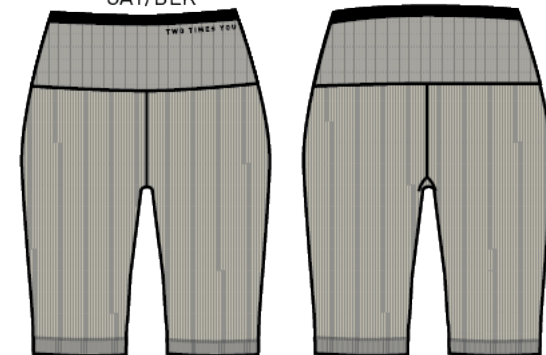

WR6463b. ENGINEERED SHORTS

HI-2021

**FORM
STORY**

KEY LOOKS
**WOMEN'S
TRAINING**



WR6458a. FORM CROP CREW



UQ6581f. MULTIPLY CAP



**WA6473b. FORM BLOCK HI-RISE
COMPRESSION TIGHTS**



WR6459a. MOTION CROP (medium impact)

HI-2021

**MOTION
STORY**

KEY LOOKS
**WOMEN'S
TRAINING**

BLK/BLK



WR6457a. COMMUTE JACKET

CBY/RST

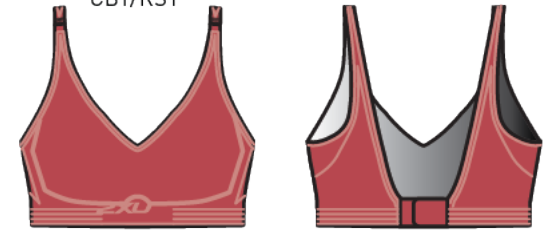

WR6455a. NO DISTRACTION CROP

CBY/RST

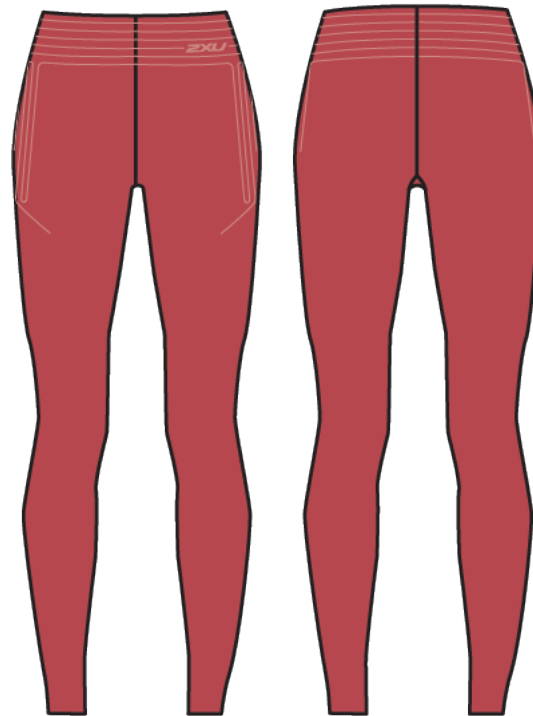

**WA6456b. NO DISTRACTION HI-RISE
COMPRESSION TIGHTS**

BLK/BLK



WR6416a. MOTION MESH TANK

HI-2021

**WARMTH
STORY**

KEY LOOKS
**WOMEN'S
RUNNING**

BLK/BRF



WR6580a. IGNITION INSULATION JACKET

GRM/SRF



WR6562a. IGNITION 1/4 ZIP

BLM/SRF



WR6342a. IGNITION BASE LAYER LS

BLK/SIL



UQ5340h. RUN GLOVE

BLK/SSR



WA6312b. WIND DEFENCE COMPRESSION TIGHT

GRM/SRF

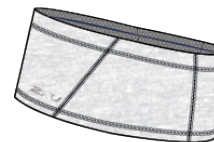

UQ6549f. IGNITION HEADBAND

HI-2021

VENTILATION STORY

KEY LOOKS WOMEN'S RUNNING

PCL/ORF

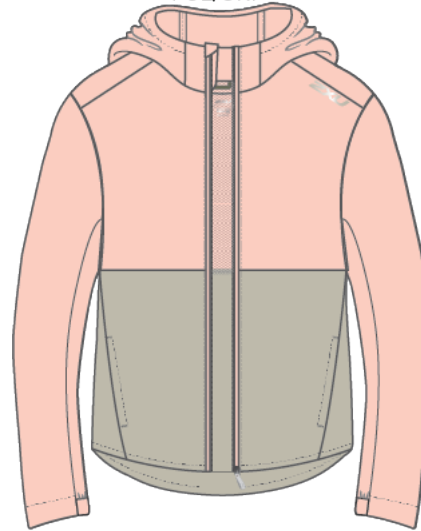

WR6538a. AERO JACKET

WHT/SRF

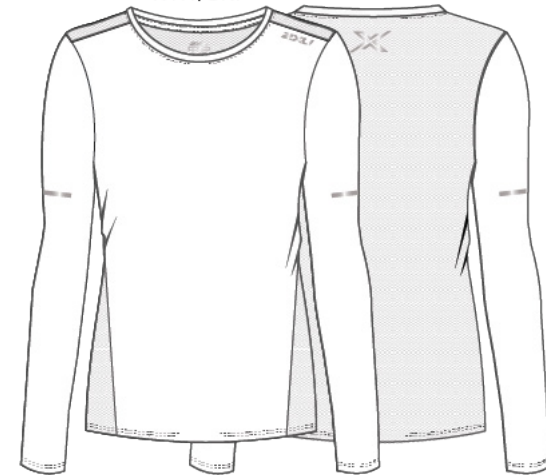

WR6564a. AERO L/S

BLK/BLK

ALP/PCL



WR6214a. LIGHT SPEED
HI-IMPACT BRA

OAT/ORF

BLK/SRF

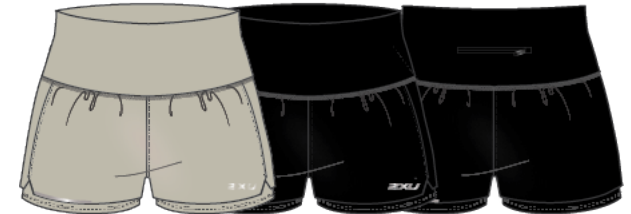

WR6533b. AERO 2-IN-1 3 INCH SHORT

WHT/PCL



UA5052e. VECTR LIGHT
CUSHION SOCKS

ALP/BLK

PCL/WHT



UQ6165f. PERFORMANCE VISOR

HI-2021

LIGHTWEIGHT STORY #1

KEY LOOKS WOMEN'S RUNNING

CBY/CBF



WR6513a. LIGHT SPEED WP JACKET

CBY/CBY BLK/BLK

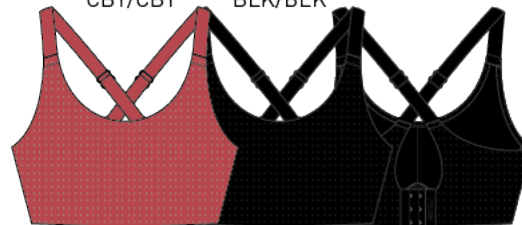

WR6347a. AERO MEDIUM IMPACT BRA

CBY/BRF BLK/SRF



WR6563a. LIGHT SPEED 1/2 ZIP

BLK/CBF BLK/GRF BLK/BRF



WA6523b. LIGHT SPEED
MID-RISE COMPRESSION TIGHT

HI-2021

KEY LOOKS
WOMEN'S
RUNNING

MDN/WRF



WR6563a. LIGHT SPEED 1/2 ZIP

CDB/SRF

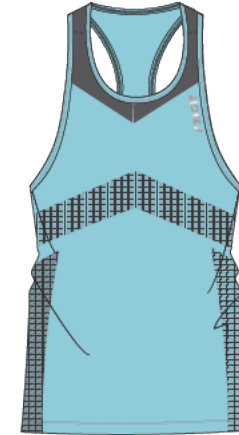

WR6515a. LIGHT SPEED TECH SINGLET

MDN/ELS



WA6527b. AERO SCULPT HI-RISE
COMPRESSION TIGHTS

CDB/MDN



UQ6540f. LIGHT SPEED CAP

HI-2021

KEY LOOKS
WOMEN'S
TRANSIT

INSULATION
IN MOTION
STORY

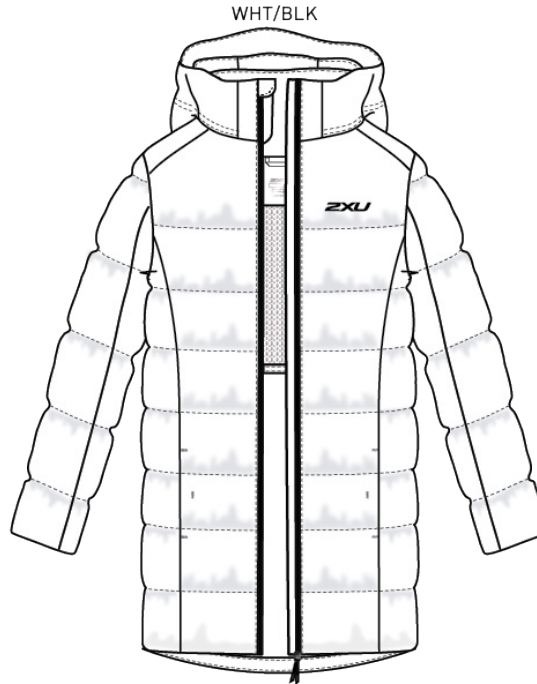

WR6284b. UTILITY INSULATION LONGLINE

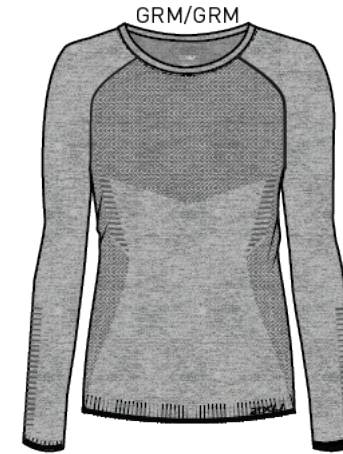

WR6450a. MOTION TECH LS

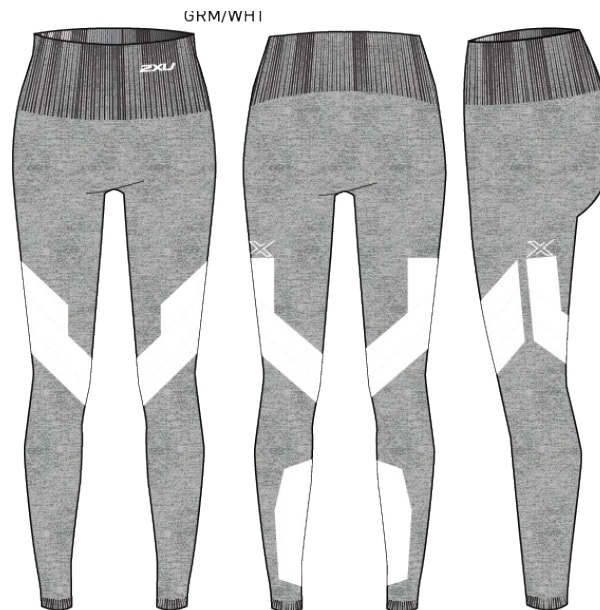

WR6472b. MOTION TECH TIGHTS

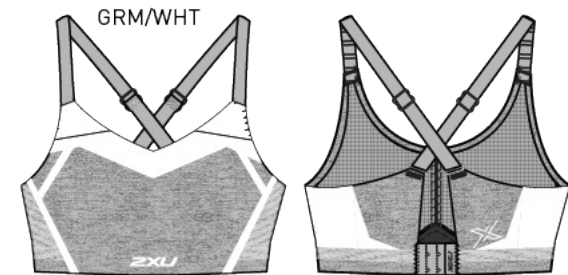

WR6471a. MOTION TECH BRA



UQ6581f. MULTIPLY CAP

HI-2021

**WARMTH
STORY**

KEY LOOKS
**MEN'S
RUNNING**

BLK/BRF



MR6511a. IGNITION INSULATION VEST

TRB/BRF



MR6554a. IGNITION 1/4 ZIP

ECH/BRF

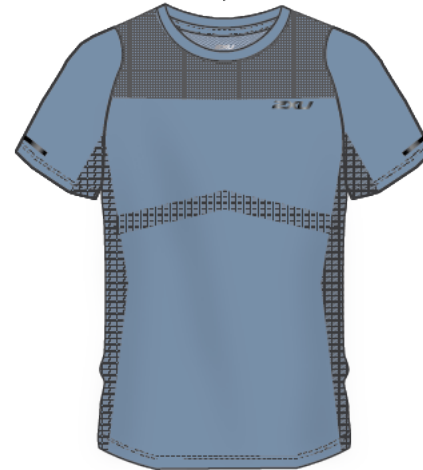

MR6503a. LIGHT SPEED TECH TEE

TRB/BRF



UQ6549f. IGNITION HEADBAND

BLK/BRF



MR6507b. LIGHT SPEED JOGGER

HI-2021

**LIGHTWEIGHT
STORY**

KEY LOOKS

**MEN'S
RUNNING**

AME/ARF



MR6499a. LIGHT SPEED WP JACKET

LGA/BRF



MR6502a. LIGHT SPEED TEE

BLK/BRF



MR6505b. LIGHT SPEED 7 INCH COVER SHORTS

BLK/ARF



MA5331b. LIGHT SPEED COMPRESSION SHORTS

BLK/SRF



UA6539e. REFLECTIVE
VECTR FULL LENGTH

BLK/FLW



UQ6542f. LIGHT SPEED
TRUCKER

HI-2021

KEY LOOKS
MEN'S
RUNNING

VENTILATION
STORY

OAT/BRF



MR6557a. AERO TEE

BLK/SRF



UQ6451f. PACKABLE RUN CAP

ALP/KRF



MR6532b. AERO 5 INCH SHORT (brief liner)

BLK/SRF



MA6108b. MA6108b AERO VENT
COMPRESSION SHORTS

ALP/KWI



UA5052e. VECTR LIGHT CUSHION SOCKS

HI-2021

**COMMUTE
STORY**

KEY LOOKS
**MEN'S
TRAINING**



MR6480a. COMMUTE WINDBREAKER

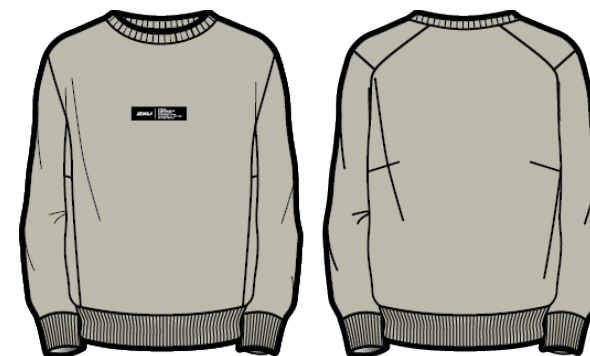

MR6481a. CONTENDER CREW

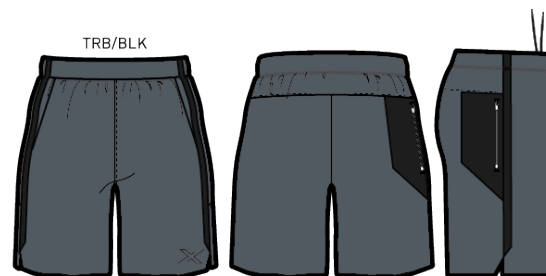

MR6479b. MOTION 8 INCH SHORT



MR6475a. MOTION TEE



MA5642b. FLIGHT COMPRESSION TIGHTS



UA5053e. VECTR CUSHION CREW SOCKS

HI-2021

**MOTION
STORY**

KEY LOOKS
**MEN'S
TRAINING**

SAP/LLT

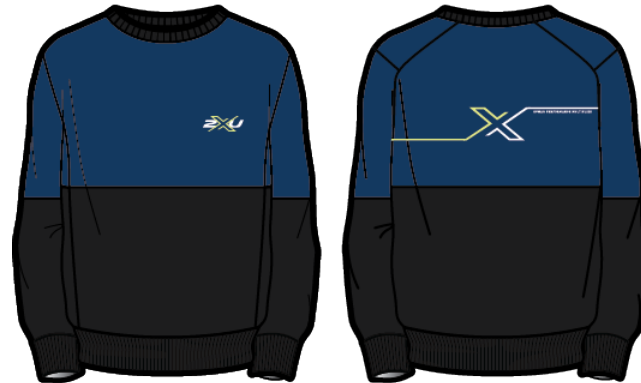

MR6490a. CONTENDER COLOUR BLOCK CREW

NVM/NVM



MR6487a. MOTION TECH TEE

MDN/AME



MR6278b. MOTION 5 INCH SHORTS

MDN/NRO



MA6488b. MOTION COMPRESSION SHORTS

BLK/WHT



UA5053e. VECTR CUSHION CREW SOCKS

HI-2021

**POWER
STORY**

KEY LOOKS
**MEN'S
TRAINING**

ALP/BLK



MR6477a. MOTION COLOUR BLOCK TEE

BLK/BLK

TRB/BLK

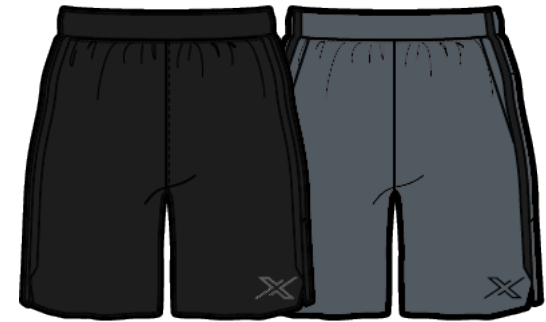

MR6278b. MOTION 5 INCH SHORTS

BLK/GLD



MA5366b. FORCE COMPRESSION SHORTS

WHT/BLK



UA5053e. VECTR CUSHION CREW SOCKS

HI-2021

KEY LOOKS
MEN'S
TRANSIT

INSULATION
STORY

CRH/BLK



MR6265a. UTILITY INSULATION JACKET

BLK/BLK



MR6268a. COMMUTE FULL ZIP HOODIE

CHM/BLK



MR6273b. COMMUTE TRACKPANT

WHT/WHT



MR6483a. CONTENDER TEE

SEASONAL
RANGEBOARD

H2 2020

2XU

HUMAN PERFORMANCE. MULTIPLIED.

RUNNING

Run your personal best,
no matter what the weather
conditions.



STAY WARM

- 1/ 600 FILL POWER DOWN INSULATION.
- 2/ RECYCLED DOUBLE-KNIT WAFFLE.
- 3/ NANO ACTIVATED CERAMIC INFUSED YARNS.
- 4/ PWX THERMAL.



STAY DRY

- 1/ ADVANCED 20K/20K AND 20K/10K WATERPROOF STRETCH MEMBRANES.
- 2/ ENVIRONMENTALLY RESPONSIBLE C6 DWR TREATMENT.



BE SEEN

REFLECTIVE LOGOS AND TRIMS
PROVIDE VISIBILITY IN LOW-LIGHT
CONDITIONS.



ESSENTIAL STORAGE

BOUNCE-FREE POCKETING
SOLUTIONS FOR SECURING PHONES,
KEYS OR CARDS.



IMPROVED PERFORMANCE

- 1/ MUSCLE CONTAINMENT STAMPING (MCS).
- 2/ GRADUATED COMPRESSION.
- 3/ PWX - MOST POWERFUL, LIGHTWEIGHT AND FLEXIBLE COMPRESSION FABRIC.



MR6223a
**PURSUIT
INSULATION
JACKET**



MR6340a
**HEAT
BASE LAYER
L/S TOP**

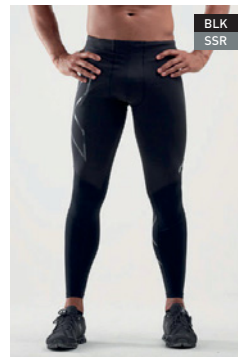

MA6311b
**WIND
DEFENCE
COMPRESSION
TIGHTS**



MA5394b
**THERMAL
ACCELERATE
COMPRESSION
TIGHTS**



MR6204a
**GHST
WATERPROOF
JACKET**

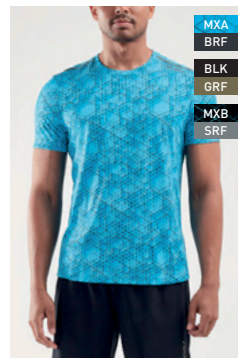

MR6210a
**GHST
S/S TEE**

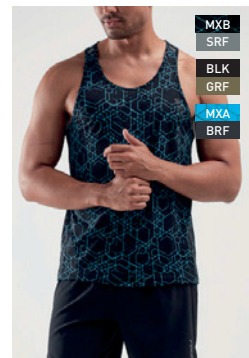
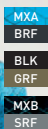

MR6211a
**GHST
SINGLET**

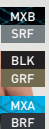

MR6215b
**GHST
3" SHORTS**



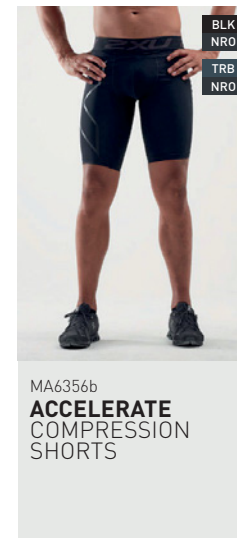
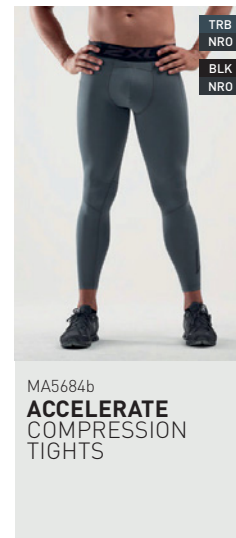
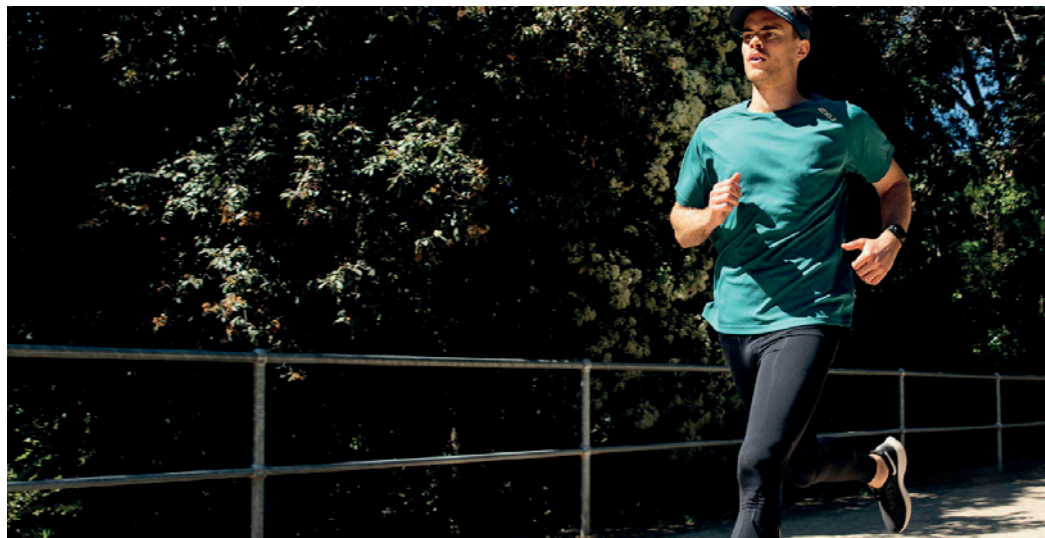
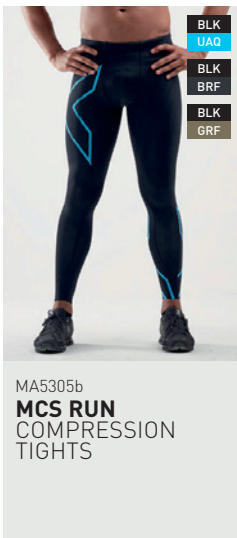
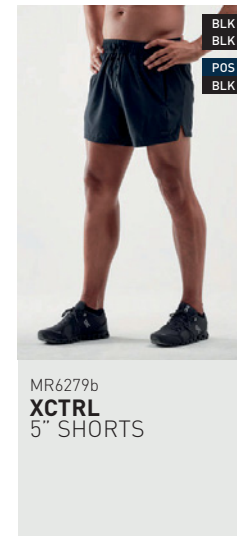
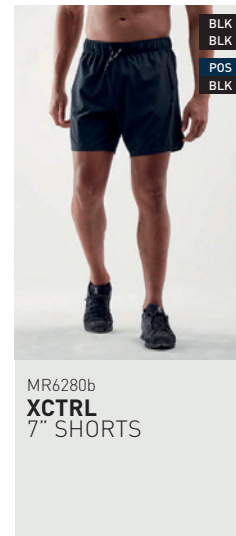
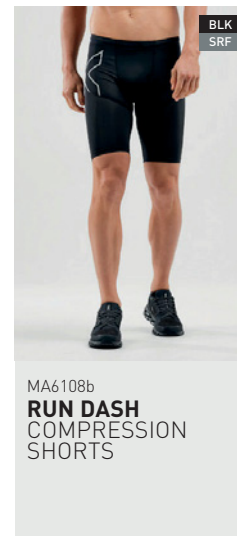
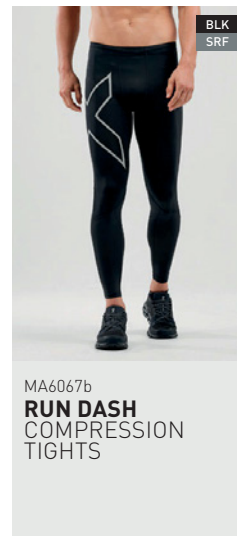
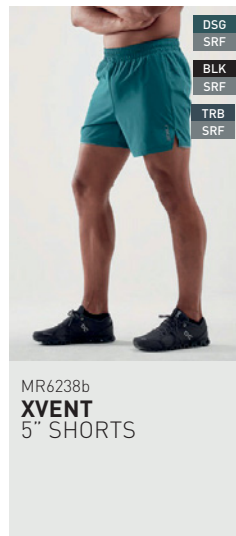
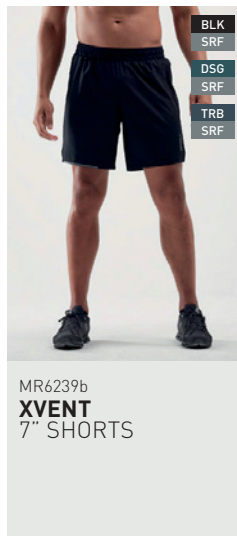
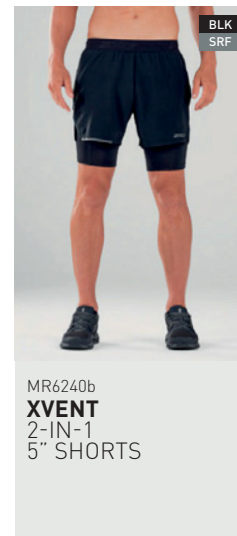
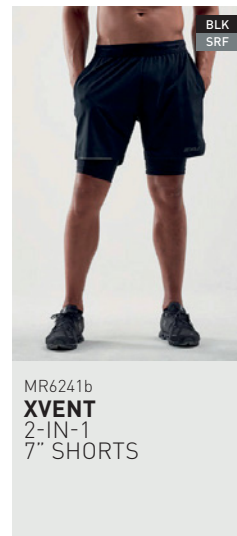
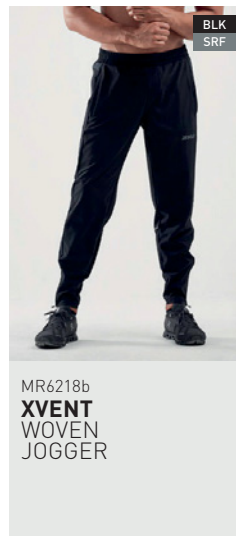
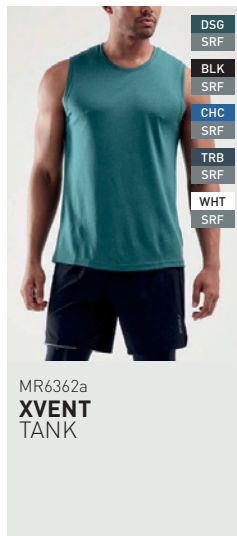
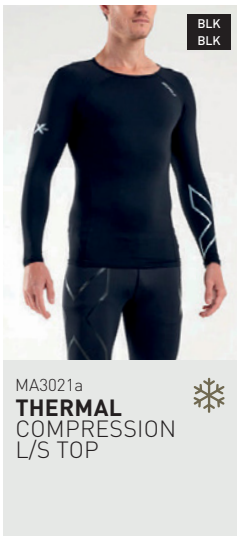
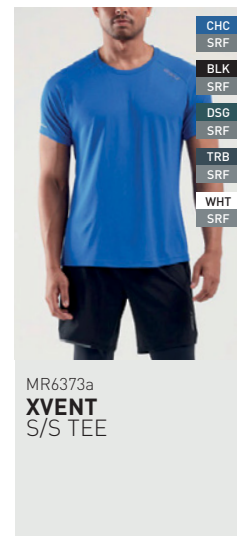
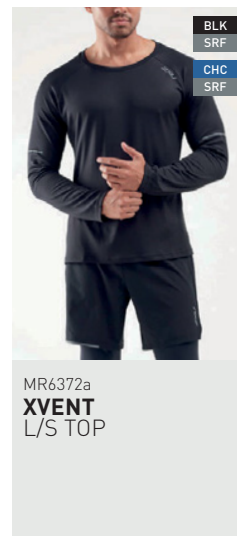
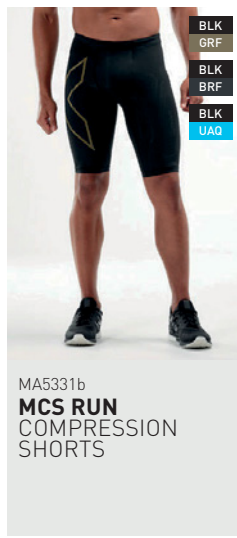
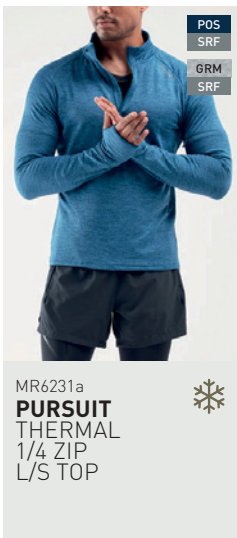

TRAINING

Designed to provide unrestricted movement and withstand the impact of your toughest workouts.



BUILT TO LAST
DURABLE GARMENT YARNS RESIST PILLING AND ABRASION.



STAY DRY
1/ PERFORATED FABRIC PROVIDES VENTILATION WHERE YOU NEED IT MOST.
2/ MOISTURE-WICKING PROPERTIES REMOVE SWEAT FROM SKIN SURFACE.



ULTIMATE COMFORT
1/ COMFORT WAISTBANDS ENSURE STREAMLINED SILHOUETTE.
2/ LONGER LENGTHS PROVIDE COVERAGE AND UNRESTRICTED MOVEMENT.



IMPROVED PERFORMANCE
1/ MUSCLE CONTAINMENT STAMPING (MCS).
2/ GRADUATED COMPRESSION.
3/ PWX - MOST POWERFUL, LIGHTWEIGHT AND FLEXIBLE COMPRESSION FABRIC.



NO SMELL
1/ ANTIBACTERIAL AND ANTI-ODOUR TECHNOLOGY KEEPS YOU FRESHER FOR LONGER.
2/ LESS WASHING REDUCES YOUR ENVIRONMENTAL FOOTPRINT.



SLE
BLK
GRM
BLK
POS
BLK

MR6275a
XCTRL
S/S TEE

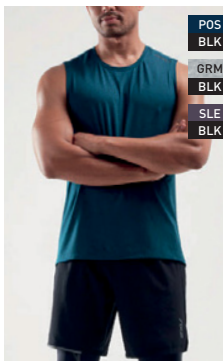

POS
BLK
GRM
BLK
SLE
BLK

MR6274a
XCTRL
TANK



CRH
BLK
BLK
BLK

MR6265a
UTILITY
INSULATION
JACKET



BLK
WHT
DSG
WHT
WHT
BLK

MR6243a
CONTENDER
S/S TEE



WHT
BLK
BLK
WHT
DSG
WHT

MR6245a
CONTENDER
TANK

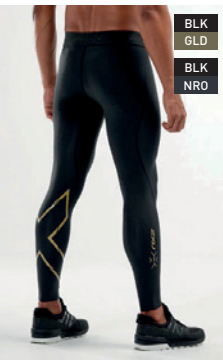

BLK
GLD
BLK
NRO

MA5365b
MCS
X TRAINING
COMPRESSION
TIGHTS

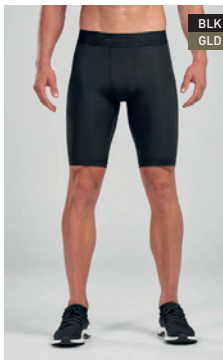

BLK
GLD

MA5366b
MCS
X TRAINING
COMPRESSION
SHORTS



BLK
SIL

MA5860b
ASPIRE
COMPRESSION
TIGHTS



BLK
SIL

MA5861b
ASPIRE
COMPRESSION
SHORTS

VECTR

For every sport and every shoe,
delivering next-level support for
training and performance.



X-LOCK TECHNOLOGY

1/ PROVIDES POWERFUL ARCH AND
PLANTAR FASCIA SUPPORT.
2/ SECURES SOCK ON FOOT DECREASING
RISK OF BLISTERING.



SEAMLESS TOE BOX

PROMOTES NATURAL TOE SPLAY
IMPROVING BALANCE, ALIGNMENT
AND COMFORT.



ANATOMICAL DESIGN

CONFORMS TO LEFT AND RIGHT
STRUCTURE OF THE FOOT FOR A
BETTER FIT.



MESH PANELS

MOISTURE WICKING YARNS AND
ZONED MESH VENTILATION AREAS
KEEP YOUR FEET COOL AND DRY.



NO SMELL

1/ ANTIBACTERIAL AND
ANTI-ODOUR TECHNOLOGY KEEPS
YOU FRESHER FOR LONGER.
2/ LESS WASHING REDUCES YOUR
ENVIRONMENTAL FOOTPRINT.



TTM
BLK
TTM
WHT
GRY



UA5041e
VECTR
ULTRALIGHT
NO SHOW
SOCKS

BLK
TTM
WHT
GRY



UA5046e
VECTR
ULTRALIGHT
1/4 CREW
SOCKS

WHT
GRY
BLK
TTM



UA5051e
VECTR
ULTRALIGHT
CREW SOCKS

BLK
TTM
HPK
GRY
TTM
BLK
WHT
GRY



UA5155e
VECTR
LIGHT CUSHION
FULL LENGTH
SOCKS

- VBB
- GRY
- BLK
- TTM
- MAG
- LGY
- WHT
- GRY



UA5042e
VECTR LIGHT CUSHION NO SHOW SOCKS

- BLK
- TTM
- BSL
- GRY
- DYP
- GRY
- WHT
- GRY



UA5043e
VECTR CUSHION NO SHOW SOCKS

- GRY
- GRY
- BLK
- TTM



UA5044e
VECTR MERINO LIGHT CUSHION NO SHOW SOCKS ❄️

- WHT
- GRY
- BLK
- TTM



UA5047e
VECTR LIGHT CUSHION 1/4 CREW SOCKS

- BLK
- TTM
- WHT
- GRY



UA5048e
VECTR CUSHION 1/4 CREW SOCKS

- GRY
- GRY
- BLK
- TTM



UA5049e
VECTR MERINO LIGHT CUSHION 1/4 CREW SOCKS ❄️

- BLK
- TTM
- UAQ
- TRB
- ULT
- TRB
- WHT
- GRY



UA5052e
VECTR LIGHT CUSHION CREW SOCKS

- WHT
- GRY
- BLK
- TTM
- BLK
- WHT
- WHT
- BLK
- WHT
- ULT



UA5053e
VECTR CUSHION CREW SOCKS

- GRY
- GRY
- BLK
- TTM



UA5054e
VECTR MERINO LIGHT CUSHION CREW SOCKS ❄️

- WHT
- GRY
- BLK
- TTM



UA5156e
VECTR CUSHION FULL LENGTH SOCKS

- GRY
- GRY
- BLK
- TTM



UA5157e
VECTR MERINO LIGHT CUSHION FULL LENGTH SOCKS ❄️

- BLK
- TTM
- TTM
- MOS



UA5393e
VECTR ALPINE COMPRESSION SOCKS ❄️

CORE COLOURS

- BLK**
Black
- WHT**
White
- TRB**
Turbulence

SEASONAL COLOURS

- CHC**
Chilled-Cobalt
- DSG**
Dark Sage
- SLE**
Sloe
- UAQ**
Ultra Aqua
- POS**
Poseidon

REFLECTIVE COLOURS

- GRF**
Gold Reflective
- SRF**
Silver Reflective
- BRF**
Black Reflective
- UAF**
Ultra Aqua Reflective

MARLE / HEATHER COLOURS

- BLM**
Black Marle
- GRM**
Grey Marle
- CHM**
Charcoal Marle

PRINTS

- MXB**
Matrix Black
- MXA**
Matrix Aqua



PUT YOUR LOGO ON IT.

CUSTOM



TEAM/YOUTH



IMPROVED PERFORMANCE
CONSTRUCTED FROM LIGHTWEIGHT, YET POWERFUL PWX FABRIC TO ENSURE MAXIMUM POWER, WEIGHT AND FLEXIBILITY.



GRADUATED COMPRESSION
BOOSTS BLOOD FLOW TO MUSCLES, REDUCING MUSCLE SORENESS AND SWELLING WHILE IMPROVING PERFORMANCE.



STAY DRY
MOISTURE WICKING YARNS ABSORB SWEAT AWAY FROM THE SKIN, KEEPING YOUR HEAD IN THE GAME.



NO SMELL
1/ ANTIBACTERIAL AND ANTI-ODOUR TECHNOLOGY KEEPS YOU FRESHER FOR LONGER.
2/ LESS WASHING REDUCES YOUR ENVIRONMENTAL FOOTPRINT.

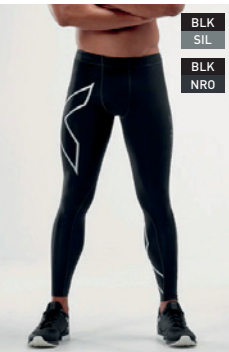

MA3849b
COMPRESSION TIGHTS

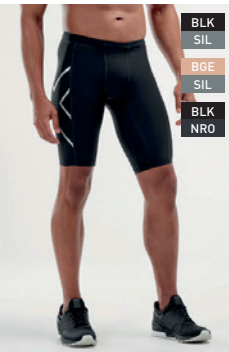

MA3851b
COMPRESSION SHORTS

TRAVEL

Arrive ready to hit the ground running.



GRADUATED COMPRESSION
IMPROVED BLOOD FLOW TO DECREASE SWELLING.



THERMOREGULATION
COTTON BLEND BRUSHED FABRIC, SOFT AGAINST SKIN AND ENSURE BODY MAINTAINS OPTIMUM TEMPERATURE.



REDUCED LONG-HAUL FATIGUE
LESS MUSCLE STIFFNESS AND LOWER RISK OF BLOOD POOLING AND DVT (DEEP VEIN THROMBOSIS).



MA5642b
FLIGHT COMPRESSION TIGHTS

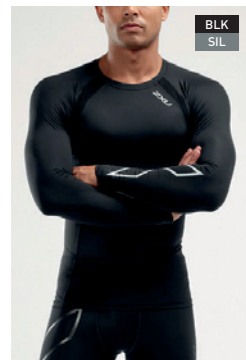

MA2308a
COMPRESSION L/S TOP



MA2307a
COMPRESSION S/S TOP

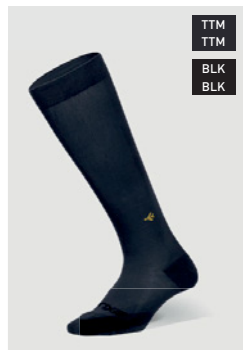

UA5689e
FLIGHT ULTRA LIGHT COMPRESSION SOCKS



UA5688e
FLIGHT COMPRESSION SOCKS

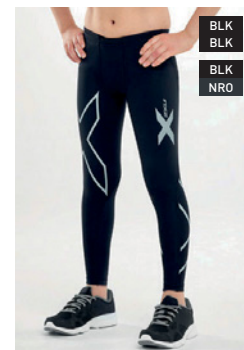

CA2549b
BOY'S COMPRESSION TIGHTS

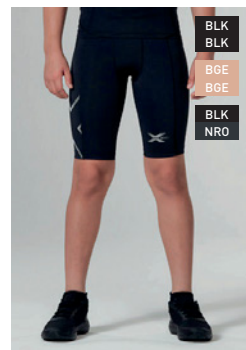

CA2548b
BOY'S COMPRESSION SHORTS

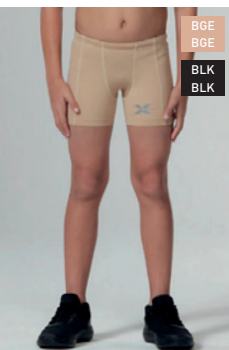

CA2547b
BOY'S COMPRESSION 1/2 SHORTS

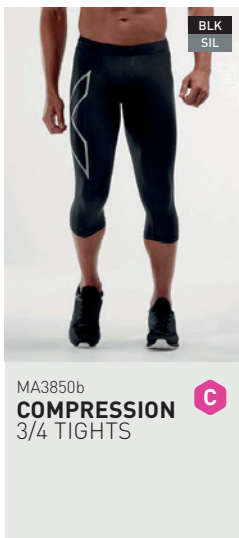

MA3850b
COMPRESSION
3/4 TIGHTS

BLK
SIL

C

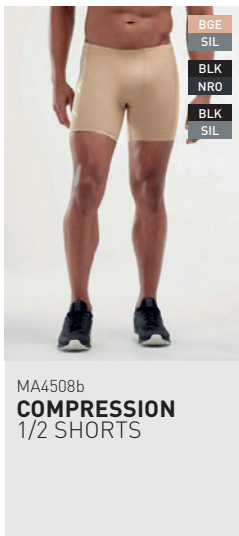
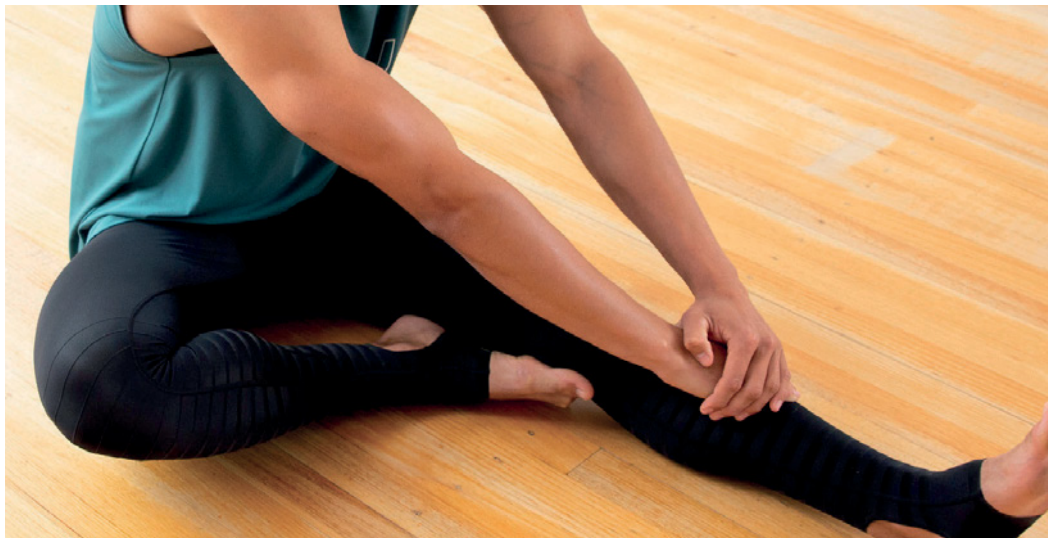

MA4508b
COMPRESSION
1/2 SHORTS

BGE
SIL
BLK
NRO
BLK
SIL

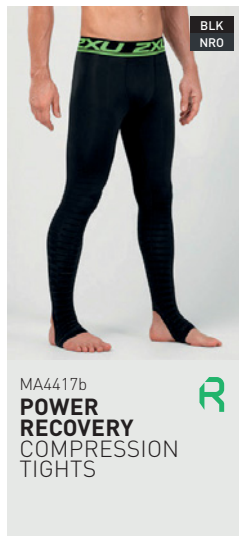

MA4417b
POWER
RECOVERY
COMPRESSION
TIGHTS

BLK
NRO

R

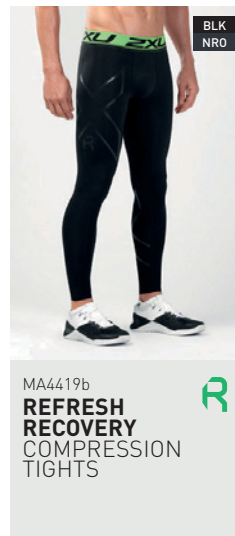

MA4419b
REFRESH
RECOVERY
COMPRESSION
TIGHTS

BLK
NRO

R

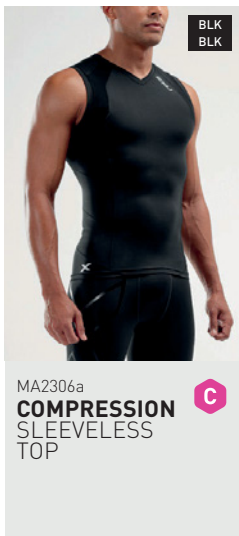

MA2306a
COMPRESSION
SLEEVELESS
TOP

BLK
BLK

C

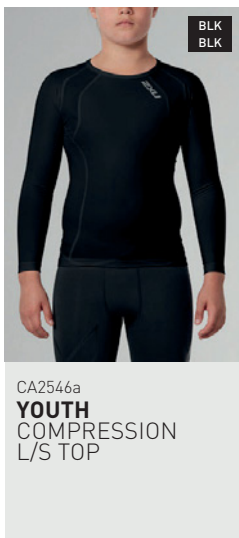

CA2546a
YOUTH
COMPRESSION
L/S TOP

BLK
BLK

RECOVERY

Get back to your peak in the fastest possible time.



GRADUATED STAMPING
IMPROVED CONTROL OF PRESSURE PROFILE AND INCREASED BLOOD FLOW TO SPEED UP RECOVERY.



OVER-FOOT COMPRESSION
POWERFUL, TARGETED RELIEF TO THE ENTIRE LOWER BODY.



COMFORT WAISTBAND
STREAMLINED SILHOUETTE AND 360-DEGREE STRETCH FOR EXTENDED WEAR.

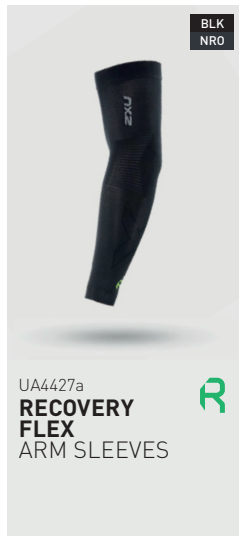

UA4427a
RECOVERY
FLEX
ARM SLEEVES

BLK
NRO

R

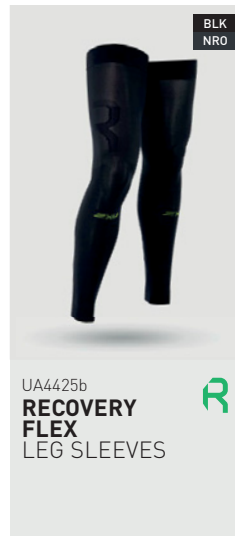

UA4425b
RECOVERY
FLEX
LEG SLEEVES

BLK
NRO

R



UQ3577f
RUN
BEANIE

BLK
BLK



UQ5352f
THERMAL
HEADBAND

BLK
BLK

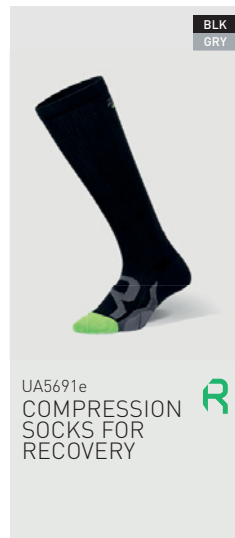

UA5691e
COMPRESSION
SOCKS FOR
RECOVERY

BLK
GRY

R

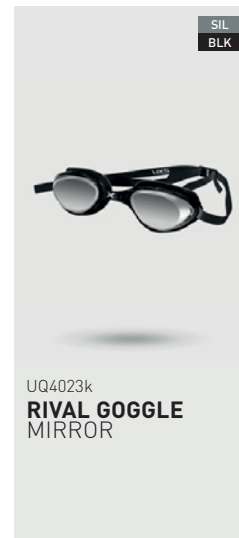

UQ4023k
RIVAL GOGGLE
MIRROR

SIL
BLK

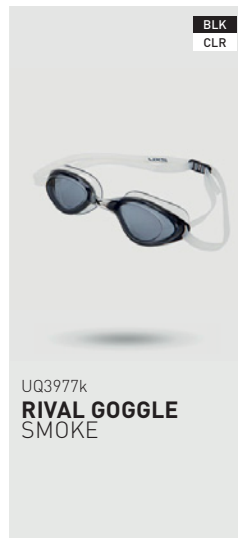

UQ3977k
RIVAL GOGGLE
SMOKE

BLK
CLR

ACCESSORIES

Elevate your performance.



BE SEEN
HIGH-QUALITY REFLECTIVE TRIMS PROVIDE VISIBILITY IN LOW-LIGHT CONDITIONS.



BUILT TO LAST
DURABLE FABRIC AND CONSTRUCTION TO SURVIVE THE ELEMENTS.

ACCESSORIES

- BLK
- GRF
- MXA
- BRF
- BEW
- WRF



UQ6371f
**VENTED
RUN CAP**

- CHC
- BLK
- BLK
- SIL
- PLT
- BLK
- POS
- WHT
- TRB
- WHT
- WHT
- SIL



UQ5685f
**RUN
CAP**

- BLK
- BLK



UQ3803g
**DISTANCE
BACKPACK**

- BLK
- BLK



UQ3804g
**GYM BAG
45L**

- BLK
- BLK



UQ5462g
**RUN
ARM BAND**

- BLK
- SIL



UQ5340h
**RUN
GLOVE**

- BLK
- SIL
- CHC
- BLK
- PLT
- BLK
- POS
- WHT
- TRB
- WHT
- WHT
- SIL



UQ5686f
**RUN
VISOR**

- TRB
- WHT
- BLK
- SIL
- CHC
- BLK
- PLT
- BLK
- POS
- WHT
- WHT
- SIL



UQ6165f
**PERFORMANCE
VISOR**

- BLK
- BLK



UQ5360g
RUN BELT

- BLK
- BLK



UQ3800g
**NUTRITION
RACE BELT**

- BLK
- BLK



UQ3799g
**TIMING CHIP
STRAP**

- BLK
- BLK
- WHT
- WHT



UA1855g
**PERFORMANCE
LOCKED LACES**

- BLK
- WHT



UQ5692f
**SKINNY
HEADBAND
2 PACK**

- BLK
- BLK
- SIL
- SIL
- WHT
- WHT



US1355f
**SILICONE
SWIM CAP**

- BLK
- BLK
- CLR
- BLX



UQ4812g
**220Z
WATERBOTTLE**

- CLR
- BLX
- BLK
- BLK



UQ4813g
**260Z
WATERBOTTLE**

- BLK
- GLD
- BLK
- NRO



UA3513a
**MCS ELITE
COMPRESSION
ARM GUARDS**

- WHT
- SIL
- BLK
- SIL



UA3196a
**COMPRESSION
ARM GUARD
(SINGLE)**

- BLK
- BLU



UQ3976k
**RIVAL GOGGLE
CLEAR**

- BLK
- BLK



UQ3805g
**TRANSITION
BAG**

- WHT
- GRY
- BLK
- GRY



UA4009a
**COMPRESSION
FLEX ARM SLEEVES
(PAIR)**

- BLK
- GRY
- WHT
- GRY



UA3567a
**COMPRESSION
FLEX ARM SLEEVE
(SINGLE)**

- BLK
- NRO
- BLK
- GLD



UA3064b
**ELITE MCS
COMPRESSION
CALF GUARDS**

- BLK
- BLK
- WHT
- WHT



UA1987b
**COMPRESSION
CALF GUARDS**



- MAG
- LGY
- BLK
- BLK
- TTM
- BLK
- VBB
- GRY
- WHT
- WHT

UA5458b
X
COMPRESSION
CALF SLEEVES



- BLK
- BLK

UA5690e
24/7
COMPRESSION
SOCKS



- TRE
- COL
- BLK
- WHT
- WHT
- BLK

UQ6141e
ANKLE SOCK
3 PACK



- TRE
- COL
- BLK
- WHT
- WHT
- BLK

UQ6140e
INVISIBLE SOCK
3 PACK



SEASONAL
RANGEBOARD

H2 2020

2XU
HUMAN PERFORMANCE. MULTIPLIED.

RUNNING

Run your personal best,
no matter what the weather
conditions.



STAY WARM

- 1/ 600 FILL POWER DOWN INSULATION.
- 2/ RECYCLED DOUBLE-KNIT WAFFLE.
- 3/ NANO ACTIVATED CERAMIC INFUSED YARNS.
- 4/ PWX THERMAL.



STAY DRY

- 1/ ADVANCED 20K/20K AND 20K/10K WATERPROOF STRETCH MEMBRANES.
- 2/ ENVIRONMENTALLY RESPONSIBLE C6 DWR TREATMENT.



BE SEEN

REFLECTIVE LOGOS AND TRIMS
PROVIDE VISIBILITY IN LOW-LIGHT
CONDITIONS.



ESSENTIAL STORAGE

BOUNCE-FREE POCKETING
SOLUTIONS FOR SECURING PHONES,
KEYS OR CARDS.



IMPROVED PERFORMANCE

- 1/ MUSCLE CONTAINMENT STAMPING (MCS).
- 2/ GRADUATED COMPRESSION.
- 3/ PWX - MOST POWERFUL, LIGHTWEIGHT AND FLEXIBLE COMPRESSION FABRIC.



WR6225a
**PURSUIT
INSULATION
JACKET**



WR6342a
**HEAT
BASE LAYER
L/S TOP**

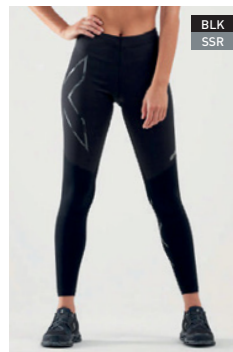

WA6312b
**WIND
DEFENCE
COMPRESSION
TIGHTS**

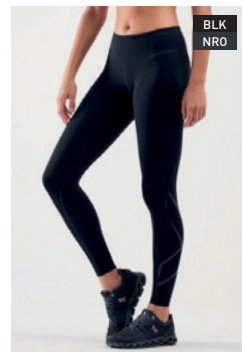

WA6352b
**THERMAL
MID-RISE
COMPRESSION
TIGHTS**



WR6205a
**GHST
WATERPROOF
JACKET**



WR6212a
**GHST
S/S TEE**

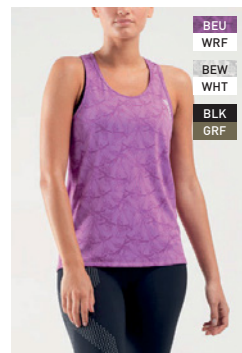

WR6213a
**GHST
SINGLET**



WR6220b
**GHST
3" SHORTS**





WR6233a
PURSUIT
THERMAL
1/4 ZIP
L/S TOP

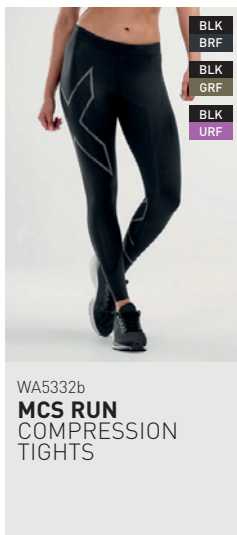

WA5332b
MCS RUN
COMPRESSION
TIGHTS

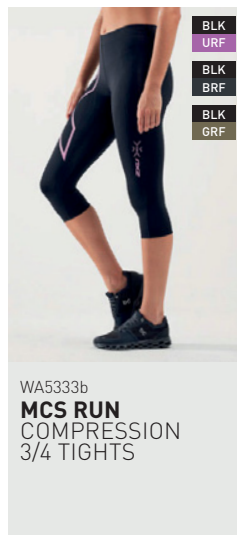

WA5333b
MCS RUN
COMPRESSION
3/4 TIGHTS

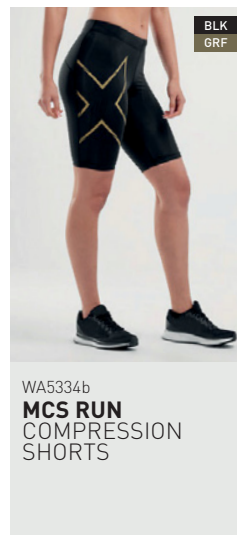

WA5334b
MCS RUN
COMPRESSION
SHORTS

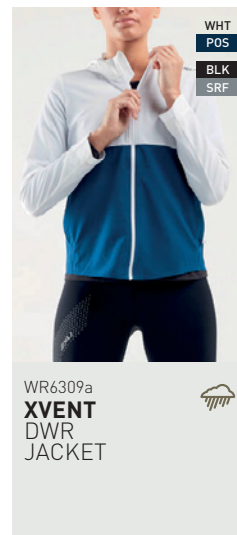

WR6309a
XVENT
DWR
JACKET

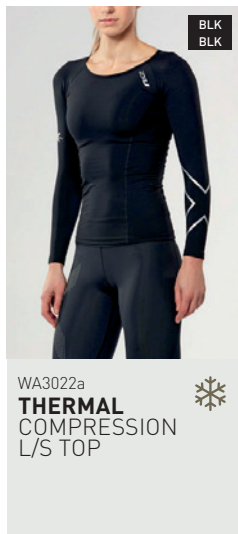

WA3022a
THERMAL
COMPRESSION
L/S TOP



WR6374a
XVENT
L/S TOP

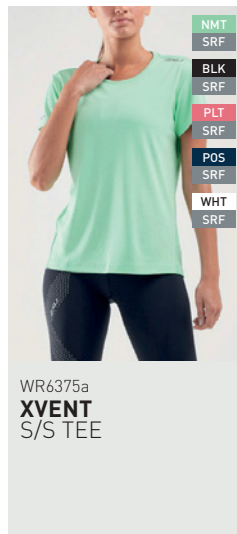

WR6375a
XVENT
S/S TEE

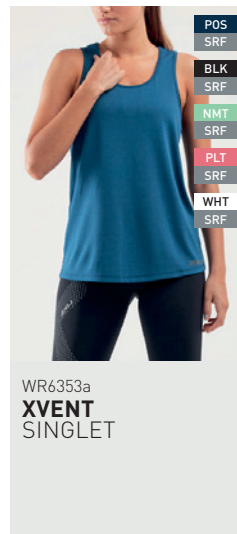

WR6353a
XVENT
SINGLET

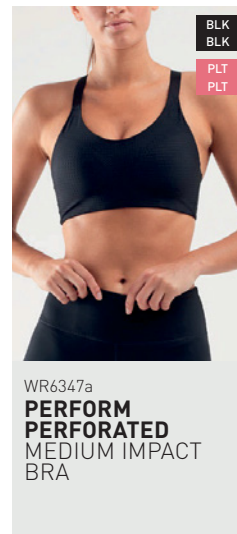

WR6347a
PERFORM
PERFORATED
MEDIUM IMPACT
BRA



WR6207a
GHST
1/2 ZIP
L/S TOP

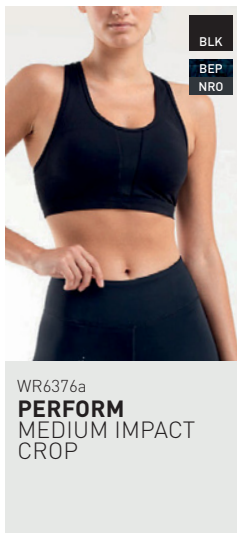

WR6376a
PERFORM
MEDIUM IMPACT
CROP

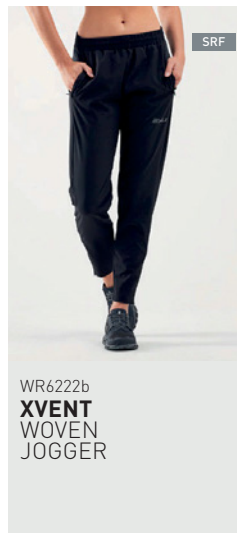

WR6222b
XVENT
WOVEN
JOGGER



WR6221b
XVENT
2-IN-1
3" SHORTS

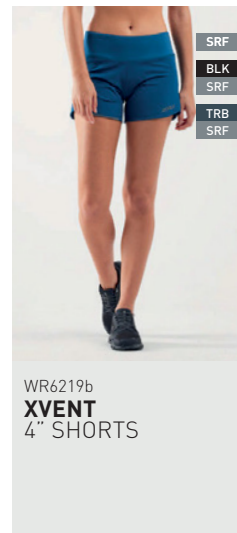

WR6219b
XVENT
4" SHORTS

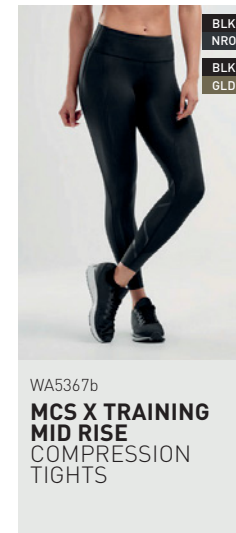

WA5367b
MCS X TRAINING
MID RISE
COMPRESSION
TIGHTS

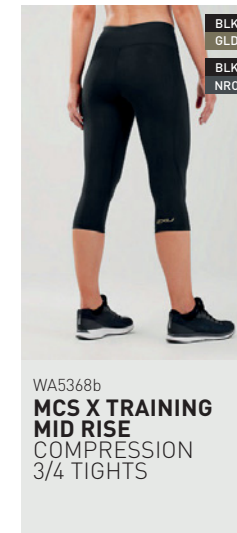

WA5368b
MCS X TRAINING
MID RISE
COMPRESSION
3/4 TIGHTS

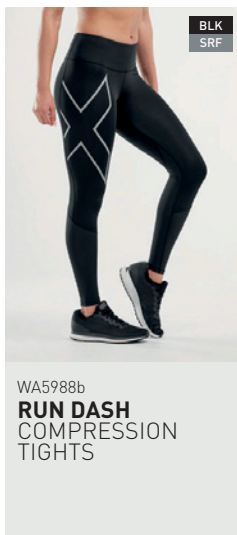

WA5988b
RUN DASH
COMPRESSION
TIGHTS

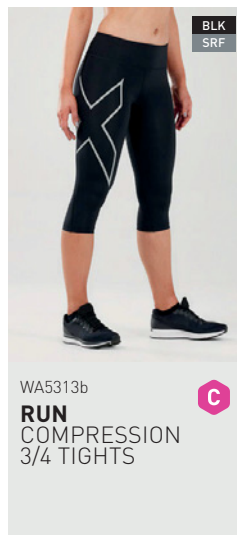

WA5313b
RUN
COMPRESSION
3/4 TIGHTS



WA5660b
PRINT
MID-RISE
COMPRESSION
3/4 TIGHTS

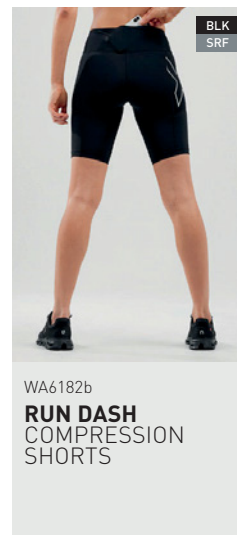

WA6182b
RUN DASH
COMPRESSION
SHORTS

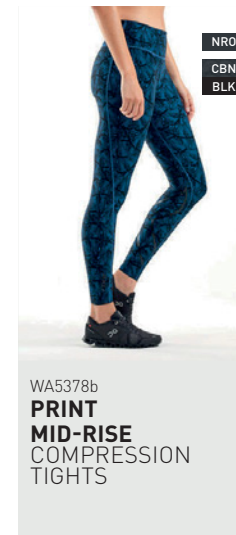

WA5378b
PRINT
MID-RISE
COMPRESSION
TIGHTS

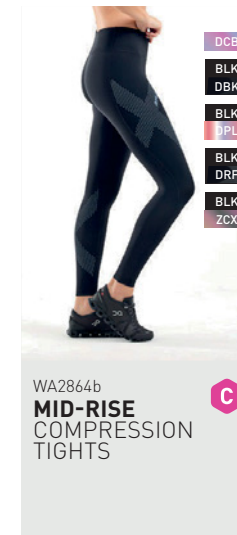

WA2864b
MID-RISE
COMPRESSION
TIGHTS

TRAINING

Designed to provide unrestricted movement and withstand the impact of your toughest workouts.



BUILT TO LAST
DURABLE GARMENT YARNS
RESIST PILLING AND ABRASION.



STAY DRY
1/ PERFORATED FABRIC PROVIDES
VENTILATION WHERE YOU NEED IT MOST.
2/ MOISTURE-WICKING PROPERTIES REMOVE
SWEAT FROM SKIN SURFACE.



ULTIMATE COMFORT
1/ COMFORT WAISTBANDS ENSURE
STREAMLINED SILHOUETTE.
2/ LONGER LENGTHS PROVIDE COVERAGE
AND UNRESTRICTED MOVEMENT.



IMPROVED PERFORMANCE
1/ MUSCLE CONTAINMENT STAMPING (MCS).
2/ GRADUATED COMPRESSION.
3/ PWX - MOST POWERFUL, LIGHTWEIGHT
AND FLEXIBLE COMPRESSION FABRIC.
4/ FITNESS - ULTRA MATTE BODY
SCULPTING LUXE FEEL.



NO SMELL
1/ ANTIBACTERIAL AND ANTI-ODOUR
TECHNOLOGY KEEPS YOU FRESHER
FOR LONGER.
2/ LESS WASHING REDUCES YOUR
ENVIRONMENTAL FOOTPRINT.