

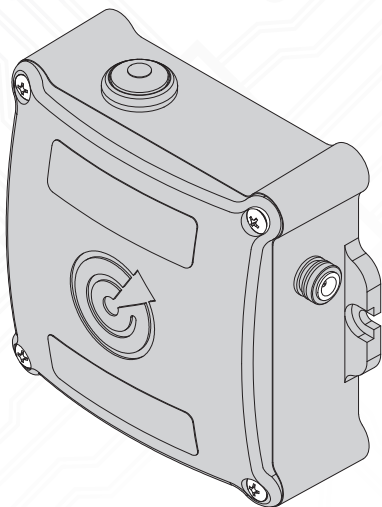

GLAS

Quick Start Guide



CORE

WIRELESS
SAFETY 

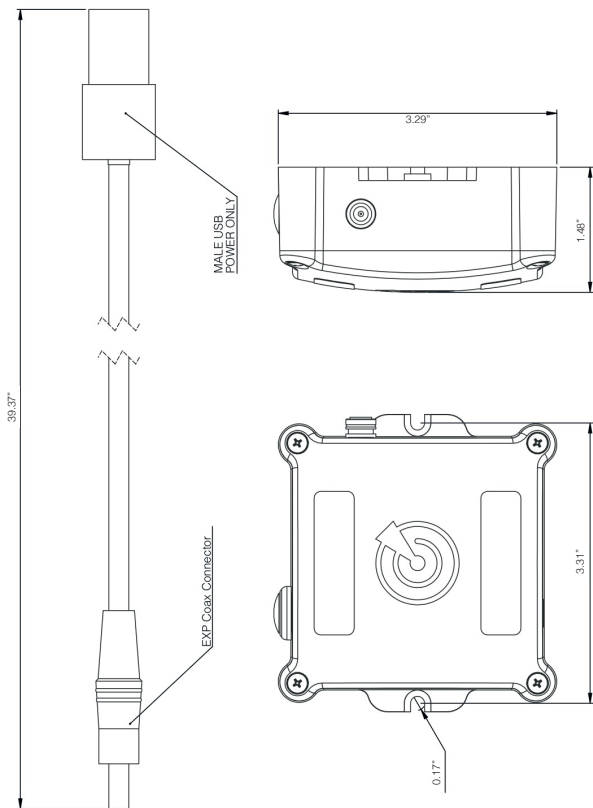

All dimensions are in inches

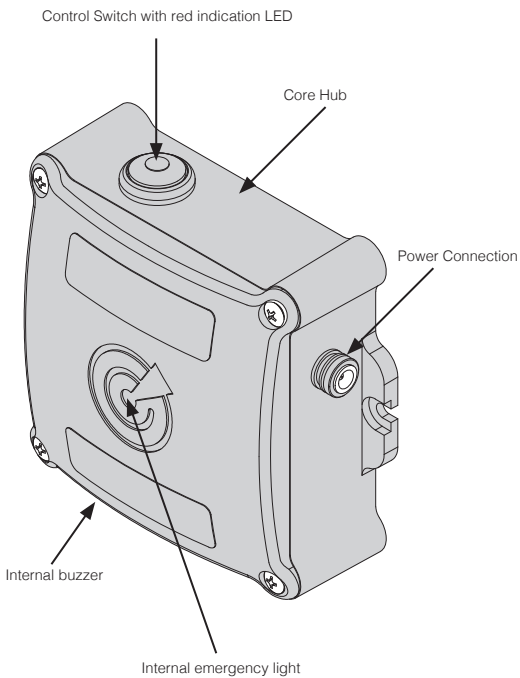

CORE

OLAS TRANSMITTERS

The OLAS TAG or the OLAS FLOAT-ON are considered OLAS transmitters. They emit a Bluetooth signal which is monitored by the OLAS receivers.

OLAS RECEIVERS

The OLAS receivers track the OLAS transmitters. OLAS receivers are:

1. OLAS Mobile application
2. CORE - Base station for OLAS Transmitters and man overboard (MOB) alarm system
3. GUARDIAN - Wireless engine kill switch and man overboard (MOB) alarm system
4. EXTENDER - This operates as a repeater to increase the range of the CORE and GUARDIAN

OLAS MOBILE APPLICATION

The OLAS mobile application allows the OLAS transmitters to be used as a MOB/proximity alarm if connected solely with OLAS transmitters. When an OLAS transmitter goes out of range an alarm is set off and overboard screens are activated.

When the OLAS mobile application is connected to the Core or Guardian, it allows greater control over the OLAS transmitters that are being tracked.

To download the app, enter "ACR OLAS" in the Apple App Store or Google Play.

IMPORTANT INFORMATION

The Core has been designed for recreational marine use. The design conforms to appropriate Electromagnetic Compatibility (EMC) regulations but for optimal performance correct installation is required. For optimum performance the mobile device and the Core should be located at least 0.5 meters from any equipment transmitting, or cables carrying radio signals including VHF Radios, antennas and cables.

QUICK START GUIDE

1. Turn on OLAS transmitters within 2 meters of the CORE (press button on the OLAS Float-On for 4 secs until it flashes green or press button on OLAS TAG for 3 secs. until it flashes green)
2. Turn on power to the Core or press the control switch once if power has already been connected
3. Wait for 30 seconds – observe the number of sound and light signals emitted by the Core. These signals represent the number of OLAS transmitters switched on within 2 meters
4. Download the OLAS mobile application (enter "ACR OLAS" in the Apple App Store or Google Play) and check battery status of all OLAS tags
5. **WARNING:** Always check the battery of any OLAS transmitter before leaving the dock. If a transmitter battery runs out whilst being used in the system it will cause the alarm to sound
6. **CHECK BEFORE FIRST USE** - Place the OLAS transmitter at least 4 inches into open water (a cup or bucket will not be enough!)
7. The alarm will sound
8. Press the control switch once to Pause the alarm
9. Bring the OLAS transmitter back within 2 meters and press the Core's switch once to reconnect
10. The Core can be switched off at any point by pressing the switch for 4 seconds or when the power is disconnected.

CORE FUNCTIONS

There are 2 operating states (Tracking and Paused) which can be applied to individual OLAS Transmitters using the OLAS mobile app:

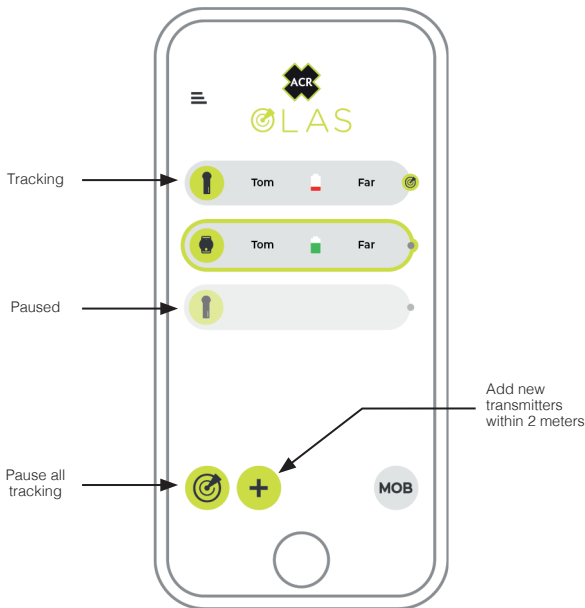

a. Alert

When an OLAS transmitter goes out of range, within 4 seconds the Core will sound its internal alert and trigger the MOB alert on the OLAS App. (the 4 second reaction time is the default setting. Reaction time is fully adjustable between 2-15 secs.)

b. Paused

Pause state should be used when the user knows an OLAS transmitter will go out of range and they do not want the Core to react i.e. leaving the boat for an extended period or swimming.

Index

1. Start up or returning to the vessel
2. Checking logged OLAS transmitter (without the OLAS mobile application)
3. Checking logged OLAS transmitter (with the OLAS mobile application)
4. OLAS mobile application features
5. Pause Tracking
6. Adding an OLAS transmitter (without the OLAS app)
7. Adding an OLAS transmitter (with the OLAS app)
8. Remove an OLAS transmitter
9. Low battery alert
10. Switching off the Core
11. Recommendations

1. START UP OR RETURNING TO THE VESSEL

- Turn on all the OLAS transmitters and place within 2 meters of the Core
- Either switch on the power to the Core by activating the power supply or press the control switch once
- The control switch LED will illuminate Red with sound indication for 3 seconds
- The Core will scan for 30 seconds while the control switch LED flashes Red
- After 30 seconds, any OLAS transmitters within 2 meters of the Core will be logged
- The number of connected OLAS transmitters is then indicated with a sound signal and Red flash per transmitter
- The control switch will illuminate Red to indicate the Core is tracking

2. CHECKING LOGGED OLAS TRANSMITTERS (WITHOUT THE OLAS MOBILE APP)

- Press the control switch once
- The number of logged OLAS transmitters is indicated with a sound signal and Red flash per transmitter

3. CHECKING LOGGED OLAS TRANSMITTERS (WITH THE OLAS MOBILE APP)

- Download and open the ACR OLAS application from Google Play or the App store
- Select the Core from the device selection page
- All OLAS transmitters that are being tracked will be indicated on the home page

4. OLAS MOBILE APPLICATION FEATURES (AVAILABLE FROM HOME SCREEN)

- Customise the OLAS transmitters name (press the unique number associated with the transmitter ~ eg. OLAS Float-On 1670 - then type the custom name)
- Check OLAS tag battery status
- Enable/Disable OLAS transmitters
- Pause all tracking

5. PAUSE TRACKING

- Press the control switch for 2 seconds, release the control switch after a single beep
- When in Paused state the control switch will flash Red for 3 seconds ON/3 seconds OFF followed by a sound signal
- Press the control switch once to re-start Tracking
- If an OLAS transmitter has been removed or switched off the Core will remain in Pause

6. ADDING AN OLAS TRANSMITTER (WITHOUT THE OLAS APP)

- Press the control switch for 2 seconds, release after a single beep, Tracking will be Paused
- Switch on the OLAS transmitter and hold it within 2 meters of the Core
- Press the control switch once, the control switch will flash Red for 10 seconds whilst scanning for new transmitters
- The number of connected OLAS transmitters is indicated with a sound signal and Red flash per transmitter

7. ADDING AN OLAS TRANSMITTER (WITH THE OLAS APP)

- Switch on the OLAS transmitter and hold it within 2 meters of the Core
- Open the home screen, press the + icon in the bottom corner, press "Scan for new transmitter"
- The control switch will flash Red for 10 seconds whilst scanning for new transmitters
- The number of connected OLAS transmitters is indicated with a sound signal and Red flash per transmitter
- The home screen will update with the newly connected transmitters

8. REMOVE AN OLAS TRANSMITTER

- Press the control switch for 4 seconds, release after the second beep – this will switch off the Core
- Switch off the OLAS transmitter/s to be removed. OLAS transmitter are turned off by pressing the button on the transmitter for 4 secs. The light on the transmitter will then flash red.
- Hold all remaining OLAS transmitters within 2 meters of the Core
- Press the control switch to switch the Core ON
- The Core will scan for 30 seconds while the control switch LED flashes Red to indicate scanning
- After 30 seconds, any OLAS transmitter within 2 meters of the Core will be tracked
- The number of connected OLAS transmitters is indicated with a sound signal and Red flash per transmitter
- The control switch will illuminate Red to indicate the Core is Tracking

9. LOW BATTERY ALERT

- A low battery alert will be initiated by the Core when an OLAS Tag's battery level goes below 20%
- The alert is indicated by a red flash every 10 seconds on the control switch and the Core Hub
- The alert will remain until the battery is changed
- You can check which OLAS tag has low battery using the OLAS app

Once you have located the tag you can **either**:

1. pause the Core, change the battery and restart tracking
2. or switch off the Core to remove the OLAS tag from the log, switch off the OLAS tag and restart the Core

10. SWITCHING OFF THE CORE

- The Core can be switched off at any point by pressing the control switch for 4 seconds
- The control switch will illuminate red with a sound signal before switching off

11. RECOMMENDATIONS

- Switch off your OLAS transmitter if it is not going to be used for longer than 24 hours
- Check the battery life of the OLAS tags in the OLAS mobile application before you leave
- Check your OLAS Float-On's battery status before your journey and charge if required

LIMITATIONS

The connection signal can be blocked by carbon and metal. Operation on carbon or, metal boats may require the Extender

SOUND AND LIGHT INDICATIONS

OPERATION	ACTION / REACTION	DURATION
Turning On	Control switch - Red Box: Low red Buzzer ON	4 seconds
No OLAS transmitter in range	Control switch - Red Box: Low red Buzzer ON	Pulsing 0.5 seconds ON/OFF
Initial scan for OLAS transmitters within 2 meters	Control switch - Red Box: Low red	Pulsing 1 second ON/OFF for 30 seconds
Indication of logged OLAS transmitters	Control switch - Red Box: Low red Buzzer ON	Pulsing 0.5 seconds ON/OFF, 1 pulse per transmitter up to max 15
Tracking OLAS transmitters	Control switch - Red	Continuous
MOB Alert	Control switch - Red Box: High red Buzzer ON	Continuous lights Pulsing buzzer
Tracking paused	Control switch - Red Box: Low red Buzzer ON	Pulsing 3 second ON/OFF Buzzer once every 6 seconds
Scanning and logging transmitters within 2 meters	Control switch - Red Box: Low red	Pulsing 1 second ON/OFF
Low battery alert for OLAS tag NOTE: OLAS Float-On does not transmit battery status	Control switch - Red Box: Low red	Pulsing once every 10 seconds

SPECIFICATION

Power/Current	5V / 13~17mA
Vessel length	50ft
Connected Transmitters	Up to 15
Weight	110 grams
Size	92 x 90 x 38 mm
LED Output	55 lm
Buzzer Output	85 db

CERTIFICATIONS

RoHS2 DIRECTIVE 2011/65/EU

(RED) (2014/53/EU)

EN 301 489-1 V2.1.1, EN 301 489-17 V3.1.1, EN 55032:2015 (CSPR 32:2015)
and EN 55035: 2017 (CSPR 35: 2016)

EN 300 328 V2.1.1

FCC part 15b CFR47 ICES-003:2012

Contains Transmitter module FCC ID: QOQBGM13P

Contains Transmitter module IC: 5123A-BGM13P

WARNING & WARRANTY

Any change or modification to this unit not expressly approved by the party responsible for compliance could void the user's authority to operate the equipment.

⚠ NOTE: This equipment has been tested and found to comply with the limits for a Class B digital device, pursuant to Part 15 of the FCC Rules.

These limits are designed to provide reasonable protection against harmful interference in a residential installation. This equipment generates, uses and can radiate radio frequency energy and, if not installed and used in accordance with the instructions, may cause harmful interference to radio Communications. However, there is no guarantee that interference will not occur in a particular installation. If this equipment does cause harmful interference to radio or television reception, which can be determined by turning the equipment off and on, the user is encouraged to try and relocate the module.

This device complies with part 15 of the FCC Rules. Operation is subject to the following two conditions: (1) This device may not cause harmful interference, and (2) this device must accept any interference received, including interference that may cause undesired operation.

Ensure your phone or tablet has maximum volume, charged battery, GPS ON and Bluetooth ON.

Ultimate Sports Engineering Ltd. accept no liability for any injuries or other damages arising from the use of their product in any circumstances.

We are here to help.

The OLAS systems are products from Ultimate Sports Engineering Ltd.

OLAS wireless systems utilise OLAS transmitters (OT) and OLAS receivers (OR).

OLAS transmitters consist of the OLAS tag and OLAS Float On.

OLAS receivers include the Core, the Guardian, the Extender and the OLAS mobile application (OLAS app)

Before using any OLAS wireless system it is imperative that you read the DISCLAIMER and the LIMITATION OF LIABILITY which follows. There is legal presumption that by using OLAS wireless systems you have read, understood and accepted the DISCLAIMER and the LIMITATION OF LIABILITY statement.

Setup

Start and setup all OLAS systems before you leave the dock and ensure all OTs are connected. Connecting the OLAS app allows visual indication of connected OTs.

Check the battery level of OLAS tags using the OLAS app. Check the battery level of OLAS Float-On's using the inbuilt color coded battery indicator.

The OLAS App

Ensure GPS is running in the background on your mobile device. Keep your mobile device plugged in to a charger as GPS drains the battery. It is advised that the app is running in the foreground to enable maximum response time. It can take up to 30 seconds for the system to respond if the phone is in locked mode.

Test the Connection Whilst In Dock

Test the connection between the OR and the OT by leaving the OR in its planned location and walk the OT to the furthest point on the vessel. Check that all OT's being used are working correctly by submersing them in more than 4 inches of open water which will activate the alarm on the receiver.

Advice

As soon as a MOB situation occurs ensure a crew member keeps visual contact and points at the MOB. Contact the emergency services and give them the co-ordinates from your vessels GPS navigation system and the time since the MOB occurred.

Use OLAS Systems frequently as a practice aid for a MOB situation.

Disclaimer:

OLAS wireless systems are an aid only and should be used alongside existing safety products and procedures. They should not be used for navigation or lifesaving procedures. The OLAS app GPS coordinates cannot be relied upon to be accurate. Whilst accuracy of between 10-30 metres can be achieved, many factors can cause larger variations. The OLAS app cannot and does not take the external environment into consideration. Wind, tide, current and other factors will affect the position of the MOB.

The OLAS app can only assist you in getting back to the position that the automatic alert was issued. The OLAS app is not warranted to be accurate. GPS reception is variable and cannot be relied on. The phone can take up to 40 seconds to get a good GPS lock even when GPS connectivity is available.

The OLAS app will be more accurate if already running for 1 minute before grabbing the GPS location. It is advised that the app is running in the foreground to enable maximum response time. It can take up to 30 seconds for the system to respond if the phone is in locked mode. The OLAS App should only be used to complement other MOB methods and procedures.

Limitation of Liability:

In no event shall Ultimate Sports Engineering Ltd or its members, representatives or suppliers be liable for any damages whatsoever (including, without limitation, loss of property, personal injury, lost revenue, lost profits, loss of goodwill, business interruption) arising from or related to the use or inability to use or reliance on any OLAS wireless system, even if Ultimate Sports Engineering Ltd or its representatives or agents have been advised of the possibility of such damages. Some jurisdictions prohibit the exclusion or limitation of liability for implied warranties or consequential damages or incidental damages, so the above limitation may not apply to you. You may have other legal rights that vary from jurisdiction to jurisdiction. To the extent any liability is found, in no event will the liability of Ultimate Sports Engineering Ltd, its members, representatives or suppliers exceed the amount paid for the OLAS wireless system inclusive of the OLAS transmitters and receivers.

Patent Notice:

The OLAS wireless systems and associated products may be covered by patents or patent pending applications.

Credits Product: Ultimate Sports Engineering Ltd

OLAS CORE Declaration of Conformity:

Hereby, Ultimate sports Engineering Ltd declares that this Bluetooth Alarm System is in compliance with Directive 2014/53/EU and Directive 2011/65/EU.

MADE IN
GREAT BRITAIN



Learn more about marine electronics and navigation we have.