

INSTALLATION INSTRUCTIONS

HydroFix™//
Hydrostatic Release Unit (HRU)

Model No.: HRU-100

Product No.: 9490.1

Y1-06-0276, Rev. E

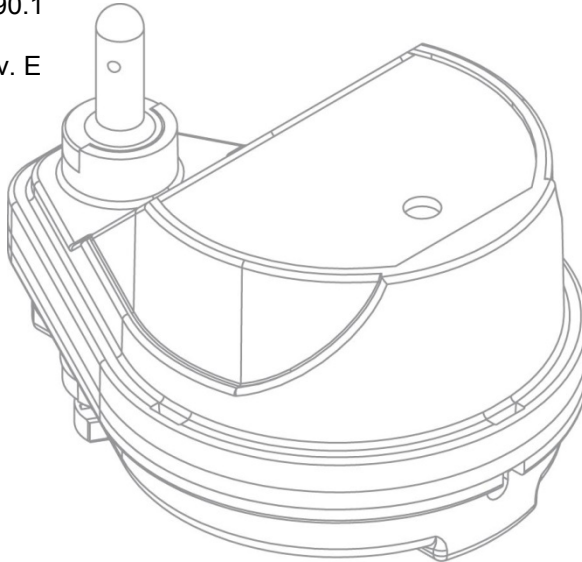



CAUTION: Before proceeding to install, test or use your new ACR Electronics product, please read this Product Support Manual in its entirety.

If you have questions regarding the contents of the manual, please contact our Technical Service Department at ACR Electronics, Inc. Please be ready to provide the technician with the page number you wish to discuss. If you have a question that is not covered in the manual, please visit our website and access the Frequently Asked Questions (FAQs) section for further information or call our Technical Service Department. If in the future you lose this manual, you may access and print a replacement on the ACR website.

Table of Contents

SECTION 1 – INTRODUCTION _____ 3

SECTION 2 – PREPARING TO INSTALL _____ 4

SECTION 3 – HOW TO DETERMINE HRU EXPIRATION DATE _____ 6

SECTION 4 – INSTALLING THE HRU IN A SeaShelter™ 4 BRACKET _____ 7

SECTION 5 – INSTALLING THE HRU IN A SeaShelter₃™ BRACKET _____ 9

SECTION 6 – INSTALLING THE HRU IN A SeaShelter₂™ BRACKET _____ 11

SECTION 7 – INSTALLING THE HRU IN A SeaShelter™ BRACKET _____ 13

APPENDIX A – WARRANTY, NOTICES _____ 15

 **PLEASE READ ALL WARNINGS, CAUTIONS AND NOTES CAREFULLY**

SECTION 1 – INTRODUCTION

Congratulations and thank you for purchasing the ACR HydroFix™ Hydrostatic Release Unit (HRU) replacement for your ACR Category I (Cat I) EPIRB.

ACR designs, manufactures and distributes quality products knowing they are used to save lives. Many of our products are required to be tested and approved by regulatory bodies worldwide. We believe in going beyond those specifications to ensure our products work when needed in real world conditions. With proper care and maintenance your ACR product will last for years.

ACR is proud to be certified to AS9100C.

This manual provides installation instructions for the HydroFix™ Hydrostatic Release Unit (HRU), model HRU-100, in supported ACR Cat I brackets only.

SECTION 2 – PREPARING TO INSTALL

UNPACKING THE HydroFix™ HRU

The HydroFix™ HRU Kit is a universal kit in that it is used for Category I ACR EPIRBs. The kit components that are required to replace the HRU in a particular model will vary with the EPIRB bracket you are servicing. The content of the universal HRU kit includes the following:

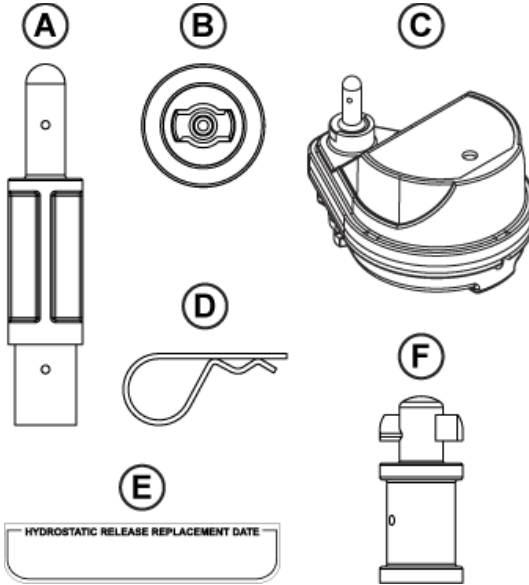

Figure 1 items:

Figure 1

- A Category I bracket (SeaShelter™ or SeaShelter™₂) release rod
- B Keyed bracket adapter
- C Replacement hydrostatic release unit (HRU)
- D Cotter pin, large
- E HRU expiration label
- F Category I bracket (SeaShelter™₃ or SeaShelter™₄) release rod

Equipment that may be required but is not included:

- // Black indelible marker
- // Phillips-head screwdriver
- // Flat-head screwdriver
- // Pliers

Notes, Cautions and Warnings

The following notes, cautions and warnings apply to all EPIRBs and **must be followed** for personal safety and proper HRU replacement.



WARNING: Failure to replace the entire assembly can cause the bracket to malfunction.



WARNING: Do not use any parts from the old HRU (the one being replaced).



WARNING: The HRU holds down the ejector spring. Take great care to hold the spring in place during removal and installation of the new HRU to prevent injury.



WARNING: Stow the EPIRB in a dry location as it will activate if out of the bracket and wet.



WARNING: Non-ACR-supplied hydrostatic release units must not be installed in ACR Category I EPIRB brackets. ACR cannot and does not warrant the performance of other manufacturers' products. Installation of a non-ACR-supplied HRU voids the warranty and potentially jeopardizes your safety.



CAUTION: Visually check the EPIRB when removing it from the bracket. It must be sent back to ACR for checkup and/or refurbishment if ANY of the following conditions exist:

- Cracks to the exterior plastics
- Activation indicator break tab is broken
- Moisture appears inside the EPIRB
- Lacquer is not present in one of the screws or appears to have been tampered with

NOTE: Some parts in this kit will not be used. Refer to Figure 1 and the instructions for your specific model for details. Discard unused parts.

SECTION 3 – HOW TO DETERMINE HRU EXPIRATION DATE

The ACR HydroFix™ HRU is a replaceable part and, as such, has dating associated with it. **The HRU must be replaced two (2) years from the install date or four (4) years from the date of manufacture, whichever comes first.**

The HRU has a calendar on its top side; the calendar should be marked with the expiration date at the time of installation, according to the following instructions.

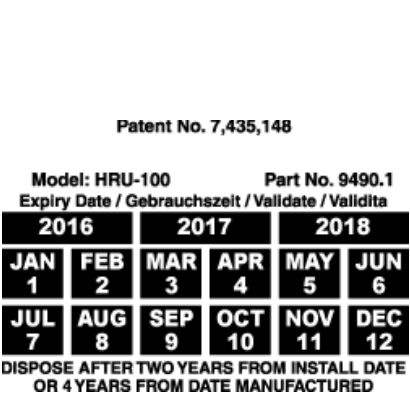

Figure 2

Date of Installation Example:
 Date of installation of New HRU or first installation of EPIRB including new HRU: **August 1, 2015**.
 This unit will need to be replaced in **August 2017**.
 Mark off “AUG 8” and “2017” on the HRU date calendar

Date of Manufacture Example:
 On the bottom of the HRU a date of manufacture is pin stamped: **0813**.
 This unit will need to be replaced in **August 2017**.
 Mark off “AUG 8” and “2017” on the HRU date calendar

SECTION 4 – INSTALLING THE HRU IN A SeaShelter™ 4 BRACKET

The following ACR EPIRBs are compatible with the SeaShelter™₄ (ACR P/N 2832):

- GlobalFix™ V4 model RLB-41

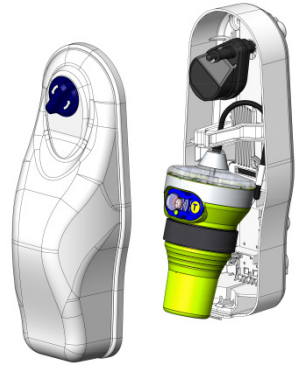

Contents of the HydroFix™ HRU Kit that you will need:

- HydroFix™ Replacement Hydrostatic Release Unit (C)
- Large cotter pin (D)
- HRU expiration label (E)
- SeaShelter™₃ or SeaShelter™₄ release rod (F)

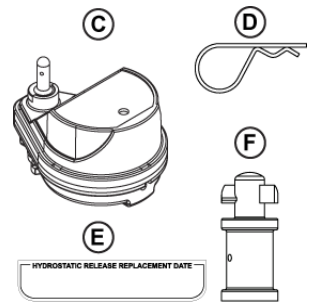

Instructions:

- 1.) Remove the front cover of the bracket and carefully release the EPIRB from the bracket.
- 2.) Remove the old HRU unit and rod from the bracket by pressing the spring release back and rotating the old HRU out of the bracket.
- 3.) Take the SeaShelter™₄ release rod (F) and place it on top of the rod on the HRU, aligning the two sets of holes on the base (see Figure A).
- 4.) Place large cotter pin (D) inside the two holes, securing the two rods together.
- 5.) **Mark the expiry date** on the HRU according to the instructions in Section 3.
- 6.) Record the expiration date on the HRU expiration label (E) with an indelible marker.
- 7.) Push the release spring back against the bracket aligning the holes on the spring with the holes on the back of the bracket.

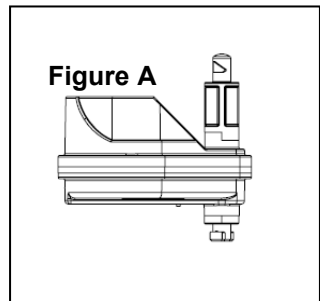

- 8.) Take the assembled HRU and place the end of the HRU through the slot.
- 9.) Turn the HRU to the left side of the bracket (see Figure B).
- 10.) This will lock the HRU and spring into place. Carefully release the HRU and make sure it is securely in place.
- 11.) Reinstall the beacon with the activation and test buttons facing toward the front of the bracket.
- 12.) Place the bracket top cover on top of the bottom cover.
- 13.) Make sure the bottom hinge and the top handle are securely connected.
- 14.) Place HRU expiration label (E) on the outside of your bracket in a visible location.

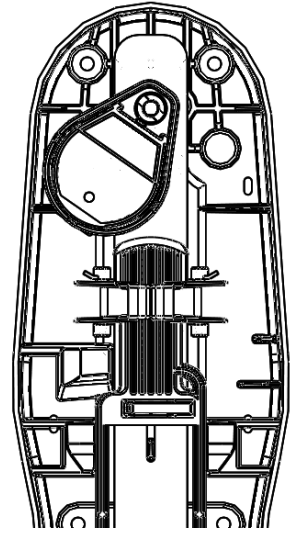

Figure B

SECTION 5 – INSTALLING THE HRU IN A SeaShelter™₃ BRACKET

The following ACR EPIRBs are compatible with the SeaShelter™₃ (ACR P/N 9501):

- GlobalFix™ iPRO, GlobalFix™ PRO, Satellite₃ 406™ or models RLB-36, RLB-37, and RLB-38



Contents of the HydroFix™ HRU Kit that you will need:

- HydroFix™ Replacement Hydrostatic Release Unit (C)
- Large cotter pin (D)
- HRU expiration label (E)
- SeaShelter™₃ or SeaShelter™₄ release rod (F)

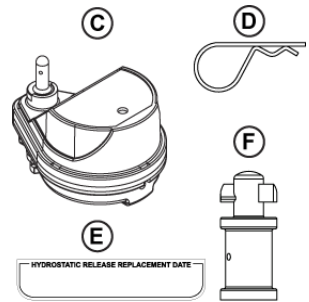

Instructions:

- 15.) Remove the front cover of the bracket and carefully release the EPIRB from the bracket.
- 16.) Remove the old HRU unit and rod from the bracket by pressing the spring release back and rotating the old HRU out of the bracket.
- 17.) Take the SeaShelter™₃ release rod (F) and place it on top of the rod on the HRU, aligning the two sets of holes on the base (see Figure A).
- 18.) Place large cotter pin (D) inside the two holes, securing the two rods together.
- 19.) **Mark the expiry date** on the HRU according to the instructions in Section 3.
- 20.) Record the expiration date on the HRU expiration label (E) with an indelible marker.
- 21.) Push the release spring back against the bracket aligning the holes on the spring with the holes on the back of the bracket.

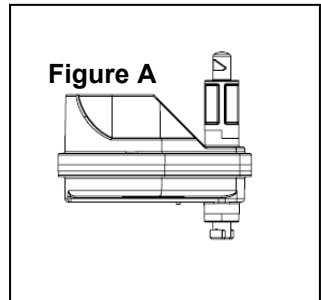

- 22.) Take the assembled HRU and place the end of the HRU through the slot.
- 23.) Turn the HRU to the left side of the bracket (see Figure B).
- 24.) This will lock the HRU and spring into place. Carefully release the HRU and make sure it is securely in place.
- 25.) Reinstall the beacon with the lanyard facing toward the back of the bracket.
- 26.) Place the bracket top cover on top of the bottom cover.
- 27.) Make sure the bottom hinge and the top handle are securely connected.
- 28.) Place HRU expiration label (E) on the outside of your bracket in a visible location.

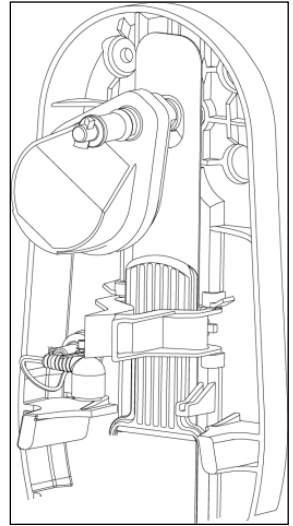

Figure B

SECTION 6 – INSTALLING THE HRU IN A SeaShelter™₂ BRACKET

The following ACR EPIRBs are compatible with the SeaShelter™₂ (ACR P/N 9435/9455):

- GlobalFix™ 406
- RapidFix™ 406
- SATELLITE₂ 406™
- Or models RLB-35, RLB-32, RLB-33



Contents of the HydroFix™ HRU Kit that you will need:

- SeaShelter™ or SeaShelter₂™ release rod (A)
- Keyed bracket adapter (B)
- HydroFix™ Replacement Hydrostatic Release Unit (C)
- Large cotter pin (D)
- HRU expiration label (E)

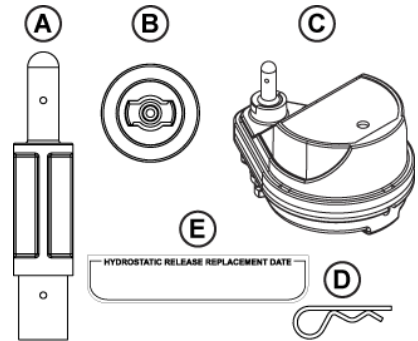

Instructions:

- 1.) Remove the front cover of the bracket and carefully release the EPIRB from the bracket.
- 2.) Remove the old HRU unit and rod from the bracket by pressing the spring release back and sliding the old HRU up and out of the bracket.
- 3.) Take the SeaShelter™₂ release rod (A) and place it on top of the rod on the HRU, aligning the two sets of holes on the base (see Figure A).
- 4.) Place large cotter pin (D) inside the two holes, securing the two rods together.
- 5.) Place keyed bracket adapter (B) on the bottom of the HRU. This part is keyed so that it will fit together only one way. Turn to the right until it snaps into place.
- 6.) **Mark the expiry date** on the HRU according to the instructions in Section 3.

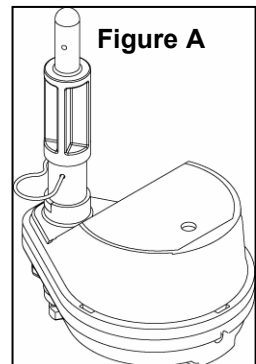

- 7.) Record the expiration date on the HRU expiration label (E) with an indelible marker.
- 8.) Push the release spring back against the bracket aligning the holes on the spring with the holes on the back of the bracket.
- 9.) Take the assembled HRU and place the washer end of the HRU through the larger top hole and slide down into the smaller slot.
- 10.) Turn the HRU to the left side of the bracket (see Figure B).
- 11.) This will lock the HRU and spring into place. Carefully release the HRU and make sure it is securely in place.
- 12.) Reinstall the beacon with the lanyard facing toward the back of the bracket.
- 13.) Place the bracket top cover on top of the bottom cover and maneuver the HRU rod to come out the rod hole on the bracket.
- 14.) Make sure the bottom hinge and the top bracket are securely connected.
- 15.) Place a cotter pin into the top of the HRU release rod locking the top cover in place.
- 16.) Place HRU expiration label (E) on the outside of your bracket in a visible location.

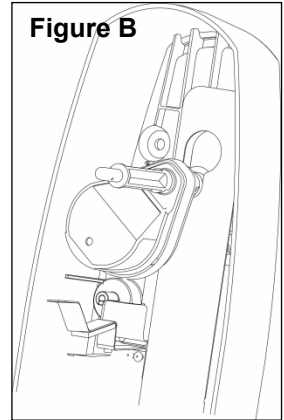

SECTION 7 – INSTALLING THE HRU IN A SeaShelter™ BRACKET

The ACR SeaShelter™ is a discontinued product that looks like this:



Contents of the HydroFix™ HRU Kit that you will need:

- SeaShelter™ or SeaShelter₂™ release rod (A)
- Keyed bracket adapter (B)
- HydroFix™ Replacement Hydrostatic Release Unit (C)
- Large cotter pin (D)
- HRU expiration label (E)

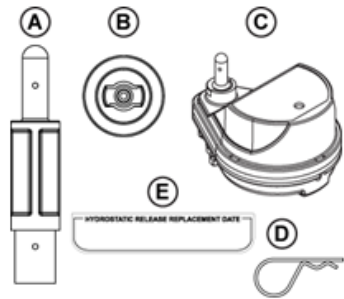

Tools required: Flat-head screwdriver

Instructions:

- 1.) Remove the front cover and carefully release the EPIRB from the bracket. If the front cover of the SeaShelter™ contains a metal bushing where the HRU rod is secured close (see Figure A), use a flat-head screwdriver and pry the bushing out of the top case and discard. This bushing prevents the HRU rod from securing to the cotter pin.
- 2.) Remove the old HRU unit and rod from the bracket by pressing the spring release back and sliding the old HRU up and out of the bracket.
- 3.) Take the SeaShelter™ release rod (A) and place it on top of the rod on the HRU aligning the two sets of holes on the base (see Figure B).

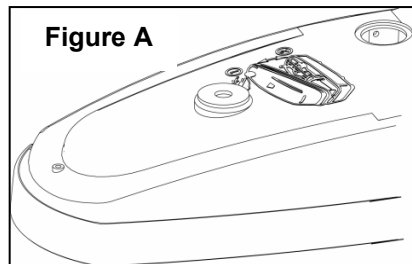

- 4.) Place large cotter pin (D) inside the two holes, securing the two rods together.
- 5.) Place keyed bracket adapter (B) on the bottom of the HRU. This part is keyed so that it will fit together only one way. Turn to the right until it snaps into place.
- 6.) **Mark the expiry date** on the HRU according to the instructions in Section 3.
- 7.) Record the expiration date on the HRU expiration label (E) with an indelible marker.
- 8.) Push the release spring back against the bracket aligning the holes on the spring with the holes in the back of the bracket.
- 9.) Take the assembled HRU and place the washer end of the HRU through the larger top hole and slide down into the smaller slot (see Figure C), locking the HRU and spring into place.
- 10.) Carefully release the HRU and make sure it is securely in place.
- 11.) Reinstall the beacon with the lanyard facing toward the back of the bracket.
- 12.) Put the top cover on the base, maneuvering the HRU through the rod hole on the bracket.
- 13.) Verify the bottom hinge and the top bracket are securely connected.
- 14.) Place a cotter pin into the top of the HRU release rod, locking the top cover in place.
- 15.) Place HRU expiration label (E) on the outside of the bracket in a visible location.

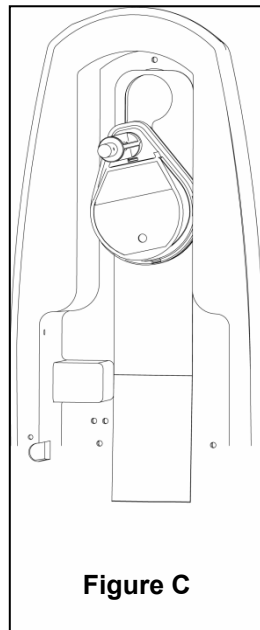
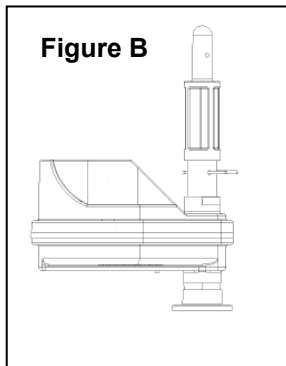

APPENDIX A – WARRANTY, NOTICES

LIMITED WARRANTY

This product is warranted against factory defects in material and workmanship for a period of 1 (one) year* from date of purchase or receipt as a gift. During the warranty period ACR Electronics, Inc. will repair or, at its option, replace the unit at no cost to you for labor, materials and return transportation from ACR. For further assistance, please contact our Technical Service Department at ACR Electronics, Inc.

This warranty does not apply if the product has been damaged by accident or misuse, or as a result of service or modification performed by an unauthorized factory. Except as otherwise expressly stated in the previous paragraph, THE COMPANY MAKES NO REPRESENTATION OR WARRANTY OF ANY KIND, EXPRESS OR IMPLIED, AS TO MERCHANTABILITY, FITNESS FOR A PARTICULAR PURPOSE, OR ANY OTHER MATTER WITH RESPECT TO THIS PRODUCT. The Company shall not be liable for consequential or special damages.

*Five years for the following products: EPIRB, PLB.

NOTICES

ACR Electronics diligently works to provide a high quality Product Support Manual, however, despite best efforts, information is subject to change without notice, and omissions and inaccuracies are possible. ACR cannot accept liability for manual contents. To ensure that you have the most recent version of the Product Support Manual, please visit the ACR website.

Ongoing product improvements may change product specifications without notice.

Trademarks or registered trademarks are the property of their respective owners.