

ANALYTIC SYSTEMS

Power Conversion Solutions

INSTALLATION & OPERATION MANUAL

IPSi2400 Series PURE-SINE INVERTER



INVERTER

IMPORTANT SAFETY INSTRUCTIONS

1. SAVE THESE INSTRUCTIONS — This manual contains important safety and operating instructions for the inverter.
2. Do not expose the inverter to rain or snow.
3. Use of an attachment not recommended or sold by the inverter manufacturer may result in a risk of fire, electric shock, or injury to persons.
4. Do not disassemble the inverter; take it to a qualified serviceman when service or repair is required. Incorrect reassembly may result in a risk of electric shock or fire.
5. To reduce risk of electric shock, disconnect the inverter from the input power before attempting any maintenance or cleaning. Turning off controls will not reduce this risk.
6. Never place the inverter directly above a battery; gases from the battery will corrode and damage the inverter.
7. Never allow battery acid to drip on the inverter.

GROUNDING AND AC POWER CORD CONNECTION INSTRUCTIONS — Inverters should be grounded to reduce risk of electric shock. This inverter is equipped with a chassis grounding stud, and electric receptacles capable of accepting an equipment-grounding conductor and a grounding plug.

Medical Equipment Notice

Analytic Systems does not recommend the use of their products in life support applications where failure or malfunction of this product can be reasonably expected to cause failure of the life support device or to significantly affect its safety or effectiveness. Analytic Systems does not recommend the use of any of its products in direct patient care. Examples of devices considered to be life support devices are neonatal oxygen analyzers, nerve stimulators (whether used for anesthesia, pain relief, or other purposes), auto-transfusion devices, blood pumps, defibrillators, arrhythmia detectors and alarms, pacemakers, hemodialysis systems, peritoneal dialysis systems, neonatal ventilator incubators, ventilators for both adults and infants, anesthesia ventilators, and infusion pumps as well as any other devices designated as “critical” by the U.S. FDA

HEAVY DEVICE - The IPSi2400 weighs approximately 50lbs. Please use appropriate safety measures when lifting or moving this device.



TABLE OF CONTENTS

- Front Cover
- Product Warnings and Advisories
- Table of Contents
- Introduction
- Box Contents
- Main Parts
- Operation
- Two-Stage Charging
- Installation
- Troubleshooting
- Specifications





Introduction

The IPSi2400 series *Intelligent* Pure Sinewave Inverters are designed specifically for powering computers and other sensitive AC loads in rugged, mobile, off-grid environments. They produce pure sinewave power, identical to a conventional AC outlet.

Internally, the IPSi2400 is controlled by a sophisticated Digital Signal Processor (DSP) for optimal control and the most efficient operation possible. The heavy-duty Toroidal Power Transformer steps the low voltage AC produced by the Power MOSFET Transistors from 110 or 220 VAC at 50 or 60 Hz. Additional filtering on the outputs reduces and eliminates EMI noise that can interfere with sensitive communications equipment.

The front panel features standardized high current MIL connectors to provide a solid connection to the battery and to the AC load(s), they also allow for easy interchange between 1200, 2400, and 3600 watt models without rewiring.

Built for the safest operation possible, this unit features low voltage warning with shutdown circuitry to protect the DC power source. While the Inverter is safeguarded by high voltage and over temperature protection both with shutdown circuitry. All the alarm conditions can be monitored on the bright LED indicator display which can also be mirrored on the optional remote control panel.

Using the free-to-download *InverterWizard* software from Analytic Systems, you can select the unit's output frequency, adjust the voltage shutdown thresholds and view/record in depth operating data from any PC with a standard USB interface.

Box Contents

The box you have received should contain the following:

- 1 IPSi2400 *Intelligent* Puresine Inverter
- 1 Compatible USB cable
- 1 Warranty Card
- This User Guide

If anything is damaged or missing from your box, please contact your dealer or Analytic Systems for a replacement.



Main Parts



Front Panel

- | | |
|--|---|
| <ul style="list-style-type: none"> 1. Remote Control Connection Port 2. MicroUSB Port 3. DC Input Connection: Marathon Power Stud Block (1/4" studs) 4. Chassis Grounding Stud | <ul style="list-style-type: none"> 5. Indicator LEDs 6. Lighted ON/OFF button 7. AC Output Connection: Phoenix VDFK4 Terminal Block 8. AC Output Connection: 5-15 NEMA Outlet 9. Thermal Carling 20A Circuit Breaker 10. AC Output Connection: 5-15 NEMA Outlet |
|--|---|

Rear Panel (Not Pictured)

- 1. Thermostatic Cooling Fan



Operation

Before operating, the Inverter must be properly installed and the load and power source must be properly connected. See *Installation*, *DC Connections*, and *AC connections* for more information.

The IPSi2400 is designed for simple and intuitive operation. It is also designed to function unattended and will automatically attempt to recover from any alarm conditions or malfunctions.

1. To turn the unit on, press the On/Off button.
2. The On/Off button and Invert LED will glow to indicate AC power on the output(s). Either the 50Hz or 60Hz LED will also glow corresponding to the unit's output frequency.
3. The Inverter will automatically begin supplying the loads with the voltage listed on its label.
4. To turn the unit off, push the On/Off button again and wait until all of the LEDs to turn off.

Controls and Indicators

The Inverter's front panel features 8 LED indicators to display the unit's operating condition. Their functions are detailed below.

Low Voltage: This LED blinks red when the input voltage nears the minimum limit for proper operation. It glows red when the input voltage is too low for proper operation. The Bypass LED will also glow red and the Invert LED and On/Off button will stop glowing.

High Voltage: The LED blinks red when the input voltage nears the maximum limit for proper operation. It glows red when the input voltage is too high for proper operation. The Bypass LED will also glow red and the Invert LED and On/Off button will stop glowing.

Over Temp: This LED blinks red if the unit's internal temperature nears the safe limit. The Inverter will automatically derate its maximum power rating to maintain a safe operating temperature. This LED glows red if the Inverter is too hot to operate. The Bypass LED will also glow red and the Invert LED and On/Off button will stop glowing.

Over Load: This LED blinks red if the current drawn by the load reaches the unit's continuous rating. It glows red if the current drawn reaches the peak rating.

50 Hz: This LED glows green if the Inverter is set to output frequency of 50.00 Hz. This setting can be changed using InverterWizard.

60 Hz: This LED glows green if the Inverter is set to output frequency of 60.00 Hz. This setting can be changed using InverterWizard.

Bypass: This LED glows green if the Inverter is in Bypass mode. This feature is only available on units with the Off-Line UPS option. For more information, see *Off-line UPS* section. This LED glows red if the Inverter is experiencing an alarm condition.

Invert: This LED glows green when the Inverter operating normally.



Installation

Mounting

Mount the Inverter in a WELL VENTILATED and DRY area with at least 1 inch (2.54 cm) of clearance all around the unit.

DANGER: *Do not mount the unit anywhere explosive gases can accumulate.*

A slight arc may form when the power leads are connected and, in the unlikely event of a failure, sparks may be generated inside the unit.

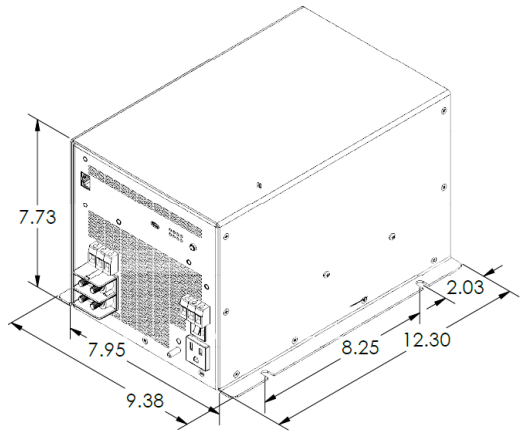

CAUTION: *The unit must be mounted on a flat horizontal surface.*

The heavy-duty toroidal power transformer inside the inverter weighs 50+ pounds. Unless the unit is mounted horizontally, it could break free from its single mounting bolt under severe vibration.

Grounding

The unit case is connected to AC Ground and AC Neutral in order to meet regulatory requirements and reduce the possibility of it generating any radio frequency interference.

The unit case must be bonded appropriately to the grounding system of the vehicle or marine vessel. On a vehicle, bond the case to the vehicle's frame. On a marine vessel, bond the case to the vessel's hull. A grounding stud is provided on the front panel for this purpose.

To ensure proper grounding, check the connection with an ohmmeter. The case is isolated from the DC input, so the DC power can be connected to a different ground from the AC output.

Disconnecting

If you need to disconnect the Inverter for service or storage:

1. Move the power switch to OFF and disconnect the DC power source.
2. With power disconnected, move the power switch to ON.
3. Leave the switch in this position for one minute to discharge the storage capacitors.
4. Return the power switch to the OFF position. Disconnect the load(s).
5. The inverter is ready for service or storage.



DC Connections

BEFORE MAKING ANY CONNECTIONS, MAKE THE POWER SWITCH IS OFF.

DC INPUT CONNECTION

Before making any connections to the unit, you will need to prepare an external circuit breaker or fuse for the DC power source. See *Specifications* for the appropriate rating.

This unit is equipped with a Marathon Terminal Block connector with 4 1/4" studs to serve as a DC input connection. An externally-supplied circuit breaker or fuse is required for safe operation.

- Connect the positive terminal of the DC power source to the indicated terminal block stud(s) using RED AWG12 stranded wire and appropriately sized lugs.
- Connect the negative terminal of the DC power source to the indicated terminal block stud(s) using BLACK AWG12 stranded wire and appropriately sized lugs.

TIP: Use the largest gauge (AWG 1/0) recommended) and shortest length of welding wire possible.

The biggest effect on Inverter performance and EMI is the length and gauge of the DC Input connections.

TIP: Make sure the wire insulation butts up tightly against the lug.

For maximum safety, no non-insulated wire should be exposed. Trim the length of non-insulated wire if necessary.

CAUTION: Do not reverse connect the input wires.

This will cause serious damage to the Inverter and will not be covered under warranty.



AC Connections

BEFORE MAKING ANY CONNECTIONS, MAKE THE POWER SWITCH IS OFF.

AC OUTPUT CONNECTIONS

This unit is equipped with two AC Output connections.

- A standard NEMA 5-15 AC receptacle is provided for connection. This connection is protected by a Thermal Carling 15A circuit breaker.
- A 30 amp, 250V rated CSA/UL approved Phoenix VDFK terminal block is also provided for wiring to a distribution panel. It is wired as follows:

Block Color	Function
Grey	AC Neutral
Green / Yellow	AC Ground
Black	AC Hot

CAUTION: Do not apply AC voltage to the output connection.

This will damage the Inverter and will not be covered under warranty.

CAUTION: This terminal block is NOT protected by a circuit breaker.

Each device wired to the distribution panel connected to the terminal block must have its own circuit breaker. Ensure that the total average load of all the devices does not exceed the continuous current rating of the unit.



Remote Control Port (Optional)

This port is intended to connect to an Analytic Systems Digital Remote Control, but can also be used for as a remote ON/OFF switch, isolated RS232 communications terminal and dry contact output fail indicator.

The remote control port is a standard RJ45 style “telephone jack” connector with Analytic Systems proprietary connections. The wire colors in the table below correspond to colors found in any standard T-568B network cable.

CAUTION: Do not connect this port to a computer!

This will cause serious damage to the Inverter and computer. This damage is not be covered under warranty.

Pin Number	Wire Color	Function
1	White/Orange Stripe	Remote ON/OFF
2	Orange	Digital Ground
3	White/Green Stripe	+12V Out
4	Blue	RX RS232
5	White/Blue Stripe	TX RS232
6	Green	Gnd RS232
7	White/Brown	Dry Contact Relay
8	Brown	Dry Contact Relay

Remote On/Off

Pins 1 (White/Orange) and 2 (Orange) can be used to turn the Inverter ON or OFF. Connect the pins together through a switch or relay to turn the Inverter OFF and disconnect them to turn the Inverter ON. The front panel power switch must be ON for this connection to function.

Isolated RS232 Communications

Pins 4 (Blue), 5 (White/Blue) and 6 (Green) are an isolated RS232 port that can be used for communication to/from the Inverter. Information on the standard data structure or custom programming is available from the Analytic Systems. Pin 4 is RX, Pin 5 is TX and Pin 6 is Return.

Dry Contact Output Fail Relay

Pins 7 (White/Brown) and 8 (Brown) are wired to the contacts of an output fail relay controlled by the processor. The contacts will be CLOSED if the Inverter is operating normally and OPEN if it has failed. An LED or buzzer can be wired to these pins to serve as a failure indicator.



Off-line UPS (Optional)

The Off-line UPS (Uninterrupted Power Source) option allows the Inverter to be used as a backup power source in the event of external AC power failure.

To set up the Off-line UPS

1. Connect the external AC power source to the AC Input Connection.
2. Connect the batteries to the DC Input Connection.
3. Connect the load to the AC Output Connection.
4. Move the Power Switch to the ON position. The Bypass LED will glow green indicating the load is drawing current from the AC Input Connection.

In the event that external AC power fails, the Inverter will sense the voltage drop, power on, and begin supplying AC power to the load. It will continue to do so until either time the external AC power is restored or the batteries become discharged.

The voltage thresholds for the Inverter to take over supplying AC Power or to stop supplying AC power to the load are all factory-preset to typical values. However, you can use the *InverterWizard* software to adjust these values to fit your specific needs. For more information, see the *InverterWizard* manual.

TIP: Choose batteries with enough capacity to ensure that the Inverter can power the load for the required amount of time in the event of AC power failure.

For example, a 2000W Inverter running from 24 VDC input will draw ~100 amps, so for 2 hours of runtime the minimum required battery capacity is 280 amps hours of capacity at 24 volts.

InverterWizard Program

The Inverter is factory preset for the input voltage, output voltage, and output frequency on the label. If these parameters are satisfactory, the Inverter can be put immediately into service.

The low voltage shutdown parameters are set for the lowest battery voltage that the Inverter will support. They are 12 Volts for a -12 model, 24 Volts for a -20 mode, and 48 Volts for a -40 model

If the Inverter is powered by alternate DC battery voltage such as 32/36 Volts for a -20 model or 72 Volts (rail) for a -40 model, then the low voltage shutdown parameters will need to be changed. You can do this using the free-to-download *InverterWizard* software from www.analyticssystem.com

With *InverterWizard*, you can also:

- Set the Output Frequency (50.00 or 60.00 Hz)
- Adjust the Output Voltage ($\pm 10\%$ range at 1 VAC intervals)
- Set the voltage thresholds for UPS (For units with the Off-line UPS Option)



Troubleshooting

This unit features eight LED indicators and an alarm buzzer to help diagnose any malfunctions. The Inverter will sound the buzzer to alert you prior to shutting down. You should immediately check the LED indicators to determine the cause of the shutdown.

LED Indicator	Meaning
LOW VOLTAGE	The input voltage is too low for normal operation.
Fix:	<p>Check that the rating of the DC power source is appropriate for the application. Check that the input cables and connections are not corroded or damaged.</p> <p>If using InverterWizard, check the Low Voltage parameters are set properly for the battery voltage you are using, for example: 21V for a 24V battery and 28V for a 32V battery.</p> <p>If everything else is normal, the cause is likely an internal component failure and the unit must be returned for repair.</p>
HIGH VOLTAGE	The input voltage is too high for normal operation.
Fix:	<p>Check that the rating of the DC power source is appropriate for the application. The Inverter can be damaged if the input voltage exceeds the maximum rating. Over-voltage damage is not covered under warranty.</p> <p>If the power source is functioning correctly, the cause is likely an internal component failure and the unit must be returned for repair.</p>
OVER TEMP	The unit's internal temperature is too hot for normal operation.
Fix:	<p>Check that the unit's cooling fans are functioning. If the fans are running, you may need to remount the Inverter for improved ventilation.</p> <p>If the fans are NOT running, the Inverter must be returned to the manufacturer for repair.</p>
OVER LOAD	The load is drawing too much current from the Inverter
Fix:	<p>The unit has been operating at peak current for longer than its intended duty cycle. Reduce the load by disconnecting some devices from the unit's AC output.</p>



Specifications

Input	-20	-40
Nominal Voltage	24, 28, 32 or 36 VDC	48 or 72 VDC
Actual Voltage	20 - 45 VDC	40 - 80 VDC
Amps (max)	120 A	60 A
Input Fuse	None, external fuse or breaker required	
Output	-110	-220
Actual Voltage	110 ± 2 VAC	220 ± 4 VAC
Amps (max)	20 A (cont) / 24 A (peak)	10 A (cont) / 12 A (peak)
Frequency	50.00 or 60.00 ± 0.01 Hz	
Distortion	<2% at 2400 Watts into resistive load	
Regulation (Line & Load)	< +/- 2.0%	
Duty Cycle	Continuous 100% for 24 hours per day	
Mechanical		
Length	15.2 in / 38.5 cm	
Width	9.4 in / 23.8 cm (including lifting handles)	
Height	9.3 in / 23.6 cm	
Clearance	1 in / 2.5 cm (all around)	
Material	Marine Grade Aluminum	
Finish	Black Powder Epoxy / Black Anodized	
Fastenings	18-8 Stainless Steel	
Weight	52.5 lb / 24.0 kg	
Connections	DC In – Marathon ST722B2502UH, 175 Amp, 300V Rating c/w Protective Snap On Cover AC Out – 2 x NEMA 5-20 receptacle or 2 x 16A 250V CEE 7/7 receptacles with circuit breaker protection, plus one 30A hardwire connection AC In – one 30A hardwire connection (with Off-Line UPS Option).	
Warranty	3 Years	
Environmental		
Efficiency	> 90% @ maximum output	
Temp Range	-25°C to +40°C @ maximum output	
Isolation	Input-Output, Input-Case & Output-Case: 1500VDC	
Safety	Built to CSA 22.2.107.1 & UL458 standards	

* Specifications subjects to change without notice.