

Current limiting protection

Ultra quiet operation (no fans)

Rugged and reliable

Simple operation



3 YEAR WARRANTY



VTC305 COMMON NEGATIVE VOLTAGE CONVERTER

Step up a 12 VDC battery to between 13.5 and 17.0 or 24.0 and 27.5 VDC in 0.5 VDC increments (via 3 position DIP switch), or stabilize a 12 or 24 VDC power system.

Safety features include reverse input protection, low input voltage alarm, low output voltage alarm, over temperature shutdown and alarm, a dry contact alarm relay output and output overvoltage crowbar. If the input voltage exceeds the regulated output voltage, the unit simply passes the voltage through with full LC filtering and a single schottky diode drop (0.5 VDC or less). Optional features include remote panel monitoring with On/Off control.

Applications include temporarily brightening 12 volt headlights or work lights, increasing voltage into an automotive or marine ignition system for hotter spark and/or prevention of failures due to voltage drop during engine start, stabilizing 12V and 24 VDC power systems in marine, automotive or aeronautical environments and more.

Available models

Input

10.5-18

10.5-28

Output

12V

24V

Applications



VTC305 | COMMON NEGATIVE VOLTAGE CONVERTER

INPUT

Input Volts Nominal (DC)	10.5 - 18	10.5 - 28
Input Amps (max)	30	
Input Fuse (AGC)	20 x 2 Amp	
Low Input Voltage Alarm	10.5 VDC	
Noise on Input Voltage Alarm	< 25 mV	
Current Limit	30 Amps in	

OUTPUT

Output Volts Nominal VDC	12	24
Output Volts Actual (DC)	Input - 1V or 13.5 to 17.0 Whichever is greater	Input - 1V or 24.0 to 27.5 Whichever is greater
Output Current (Amps)	*27	

*** The actual output current capability depends upon the input/output voltage ratio. To obtain the actual output current capability at any given input voltage, use the following formula:
Output Amps = Input Volts/Output Volts x 27
For example, at 11 VDC in and 13.6 VDC out, the output current = 11/13.6 x 27 = 22.8 amps**

Output Crowbar	Programmed output volts x 1.3
Output Ripples & Noise	< 25 mV
Low Output Voltage Alarm	Program Output Voltage minus 2.5 VDC
Transient Response	< 1V for 50% Surge
Regulation (Line & Load)	< +/- 0.5%
Duty Cycle	Continuous 100% for 24 hrs per day
Efficiency	> 90% @ Maximum Output

MECHANICAL

Dimensions	9.1 in / 23.1 cm Long x 7.8 in / 19.8 cm Wide x 2.5" / 6.4 cm High
Clearance	1.0" / 2.5cm all around
Weight	4.0 lb / 1.8 kg
Material and Finish	Marine Grade Black Anodized Aluminum with 18-8 Stainless Fasteners
Mounting	Wall or Shelf Mount
Connections	Input: Flying Leads – Red & Black, 4 ft / 1.25 m length, 10 AWG Output: Beau 4 position terminal block, 2 positive, 2 negative

ENVIRONMENTAL AND SAFETY

Operating Temperature Range	-25°C to +40°C @ maximum output. Derate Linearly 2.5% per °C from 40°C (Optional -40°C wide temperature range available)
Humidity	0 - 95% Relative Humidity (non-condensing) with standard conformal coating
Emissions	Meets FCC Part 15, Class B
Isolation	Input-Case, Input-Output and Output-Case 1500 VDC
Audible Noise	None
Duty Cycle	Continuous
Warranty	Three years parts and labor
Safety	Designed to meet CSA 22.2.107.1 & UL458

OPTIONS

- Paralleling Diodes
- European ROHS Compliant (Lead Free Manufactured)
- Electric Fork Lift (Filtering and Surge Suppression)
- Open Frame (No chassis just heat sink bars)
- Safety Special Inspection (CSA/UL)
- Heavy duty ruggedization with wide temperature range
- Custom input/output available

DIMENSIONS

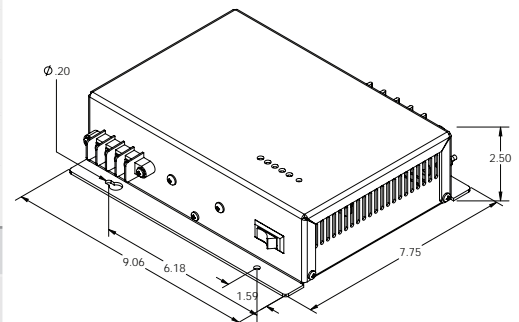

ANALYTIC SYSTEMS
Power Conversion Solutions