

# attwood®

## Water-Resistant, 90° Fuel Tank Vent

1670, 1671, 1680, 1682, 66419

### Mounting Instructions

Attwood marine hardware, navigational lighting, bilge pumps, and other marine accessories are specified more than any other brand by America's best-known boat manufacturers as original equipment. Look to Attwood for quality replacement parts and marine accessories.

### SAVE THESE INSTRUCTIONS

Form Number 69252 Rev. G

04-11

### FEATURES:

The Attwood water-resistant 90° fuel tank vent is designed for permanently-installed fuel systems and is intended for use with 5/8" vent hose. Hull thickness should be 9/16" maximum.

The unique design helps to avoid ingestion of water into the fuel tank under normal sea conditions and washdown.

The design includes a series of baffles and traps to allow air to move freely while reducing the possibility of water splashing back into the tank.

Eliminates the need for an anti-siphon loop in the vent hose and allows a more direct routing of the hose to the fuel tank requiring less hose for installation.

Meets ABYC H-24 ventilation specifications.

U.S. Patent Nos. 4,877,152 and D,314,548

### ⚠ WARNING:

DO NOT INSTALL THIS VENT IN A LOCATION LOWER THAN THE TOP OF THE FUEL TANK. IT MAY ALLOW FUEL TO ESCAPE CREATING A FIRE HAZARD.

Figure 1

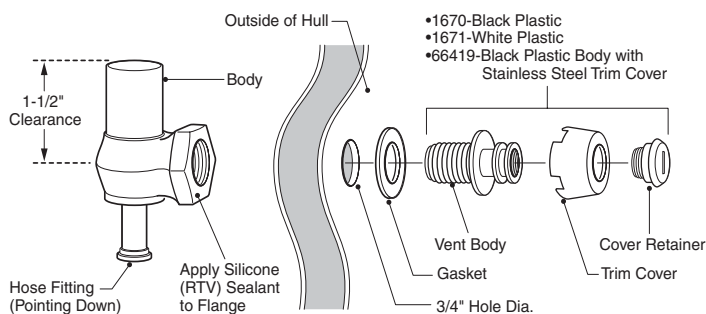

### TOOLS AND MATERIALS REQUIRED FOR INSTALLATION:

1. Drill
2. 3/4" drill bit
3. Silicone (RTV) sealant
4. Ruler or tape measure

### MOUNTING INSTRUCTIONS:

1. Select a location that is the highest point possible above the top of the fuel tank as installed in the boat under normal operating conditions. Install as high and as far forward toward the helm as practical. It is important that the vent is in a location where it will not be submerged or exposed to constant wave action or splashing. **MAKE SURE THERE IS ENOUGH ROOM INSIDE THE HULL FOR THE VENT AND HOSE BEFORE DRILLING THE MOUNTING HOLE** (See applicable figure below). Hull thickness should be 9/16" maximum.
2. Carefully drill a 3/4" diameter hole for installation of the vent. Keep the hole clear of burrs and fiberglass strands.
3. Remove the cover retainer from trim cover. Remove trim cover, vent body and gasket from P-trap body.
4. Apply a small bead of silicone (RTV) sealant on the P-trap body front flange. No sealant is required on the vent body.
5. Put gasket onto threaded area of vent body. Insert vent body into predrilled hole from outside of hull and screw into the P-trap body, making sure the hose fitting is pointing down.

### ⚠ CAUTION:

**Overtightening will damage the plastic threads.**

6. Reinstall the trim cover and cover retainer. Make sure cover retainer is fully seated. A coin or flat washer may be used to tighten the retainer.
7. Using a corrosion-resistant clamp, install vent hose to hose fitting.

Figure 1a

