



LED WAKETOWER LIGHT 5580

SAVE THESE INSTRUCTIONS

INSTALLATION INSTRUCTIONS

09/02

69448 Rev. B

FEATURES

The Attwood LED Waketower Light is designed for boats up to 39.6 ft (12 meters). It features an impact resistant, UV-stable polycarbonate housing. Light meets USCG CFR 183.810, ABYC A-16 requirements, and all applicable standards as tested by Imanna Labs. July 2008. 5580 is an All-Round Light with 2 Nautical Mile visibility.

REQUIRED FOR INSTALLATION

- Cordless drill with 1/8" and 1/4" (3mm and 6mm) bits.
- Screwdriver.
- Two #8 or #10 stainless pan head screws per light.
- Non-silicone sealant.

⚠ WARNING:

To prevent personal injury, disconnect the power source when installing or servicing this product. Always remove the boat from the water before using 120V AC power tools.

LOCATION

All-Round Lights must be mounted a minimum of 1 meter above the sidelights, on a smooth surface where the 360° beam will not be obstructed. Light must not shine on operator or on anything in operator's field of view. (Figure 1)

IMPORTANT: Before drilling mounting holes, be sure that light shines within 5° of horizontal **when the boat is floating.**

INSTALLATION, DECK MOUNT

1. To access mounting holes, gently twist lens helmet counterclockwise to remove.
2. Place light in position as shown in Figure 2.

IMPORTANT: Before drilling, be sure that light will shine within 5° of horizontal **when the boat is floating.**

3. Drill 1/8" (3mm) pilot holes for both screws using base as a guide.
4. Bring 12V DC (+) and (-) wires up through deck hole. Connect wires using waterproof crimp on butt joint connectors.
5. Activate light to verify proper operation.
6. Apply a thin bead of non-silicone sealant on underside of base to prevent water from entering hull or cabin.
7. Align and fasten base with stainless screws. Do not over tighten.
8. Snap light into base while aligning rib into slot.

FINAL WIRING

⚠ CAUTION:

Power source must be positive 12V DC only. All positive (+12V DC) wires must be fused to protect the circuit. Attwood Navigation Lights require a 1-amp fuse. Failure to make proper connections and fusing will void product warranty.

1. Neatly thread wires to dash avoiding any areas where abrasion or snagging may occur.
2. Use waterproof crimp on butt joint connectors to attach wires to a switch on the dash that allows for two-position operation - one for running lights and one for anchor lights. Test lights for proper operation. (Figure 3)

MAINTENANCE

To clean, wipe with damp cloth. Bulb is not serviceable.

Figure 1

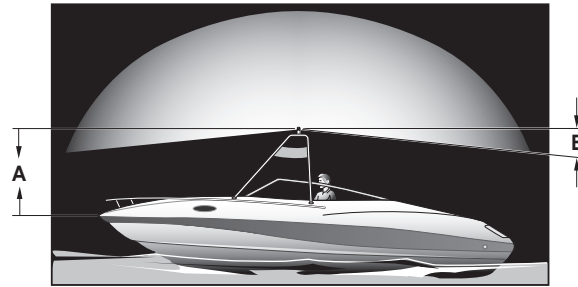

Figure 1

- A. One meter or 39-3/8"
- B. 7°

Figure 2

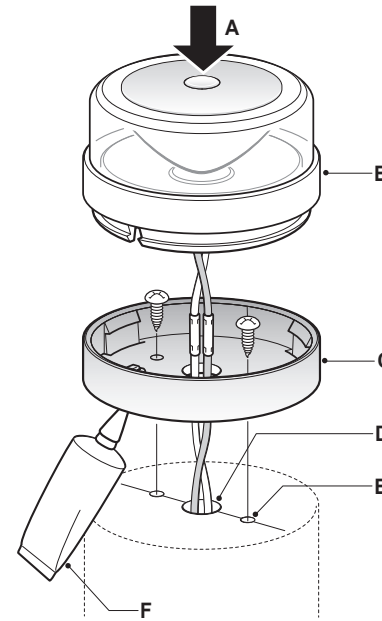

Figure 2

- A. One Time Snap
Straight Down To Secure, Not Meant To Be Removed.
- B. Lens Helmet
- C. Base
- D. 1/4" (6mm) Dia. Hole
- E. 1/8" (3mm) Pilot Holes
- F. Sealant

Figure 3

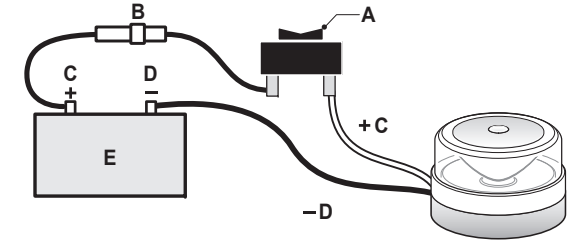

Figure 3

- A. 3-Way Switch
- B. 1-Amp Fuse
- C. Pos.
- D. Neg.
- E. 12V DC

Learn more about boat navigation lights we have.