



Light Armor Underwater Lights

HP & HPX Series

INSTALLATION INSTRUCTIONS

69540 Rev. C

REQUIRED FOR INSTALLATION

- Screwdriver
- Appropriate switch and fuse
- Drill and bits:
 - 9/16 inch (1.43 cm) for wire clearance hole
 - 3/32 inch (2.38 mm) for mounting pilot holes
- Two #8 pan head stainless steel screws

LOCATION

1. Lights are designed to be submersible and are for **underwater use only**. Lights are intended for surface mount.
2. Use template or measure and mark location for 9/16 inch wire clearance hole.

NOTE: Whenever possible, lights should be installed a minimum of 10-inches below the waterline.

DRILLING INSTRUCTIONS

1. Drill 9/16 inch (1.43 cm) hole for wire clearance.
 2. Align light engine with the position you've drilled for the wire clearance hole (Figure 1).
 3. Use the light engine or template to mark locations for the mounting screw pilot holes.
- CAUTION:** Position wire clearance hole carefully on aluminum boat so that wires do not contact hull.
4. At the marked locations, drill two pilot holes for mounting screws. Drill to adequate depth for screw length.

MOUNTING INSTRUCTIONS

1. Make wire connections according to the WIRING INSTRUCTIONS.
 2. Using marine grade underwater sealant, seal around drilled wire clearance hole and fasteners to prevent water intrusion. **Only seal where indicated in Figure 1 and 2 and fastener holes.**
 3. **DO NOT** seal over back ridges since failure to comply will cause lights to overheat and void warranty.
 4. Add bezel to light assembly (if supplied).
- CAUTION:** Screws should fit snugly against bezel assembly. **DO NOT** over tighten, doing so may cause cracking of the light housing and light failure.
5. Insert screws through bezel housing (if supplied), light engine, and gaskets then fasten light to surface. **NOTE:** If stainless steel bezel is not used, a #8 pan head stainless screw must be used (not included).

WIRING INSTRUCTIONS

The power supply must be a 12 or 24-volt DC only. Use crimp-type marine grade connectors with suitable waterproof insulation. Protect all connections with suitable materials.

NOTE: Failure to make proper connections and fuse the light properly will void the product warranty

CAUTION: Polarity is important. If wiring is mis-connected, the LED light will not operate.

1. Connect wires to fused power source (Figure 3).
2. Connect the (-) black wire to the negative (-) wire for each light from the 12/24-volt supply.
3. Connect the (+) white wire to the proper fuse switch. See *Fuse Recommendation for correct fuse size.*
4. Connect fused switch to the positive (+) 12/24-volt supply.

Fuse Recommendation:

HP	12 VDC Amps	24 VDC Amps	HPX	12 VDC Amps	24 VDC Amps
4.0	1	1	4.0	2	2
5.0	2	1	5.0	4	3
6.0	3	2	6.0	6	3

Figure 1

Apply marine sealant directly into wire clearance and screw holes drilled into boat surface.

**Gaskets are placed between light assembly and boat's surface.*

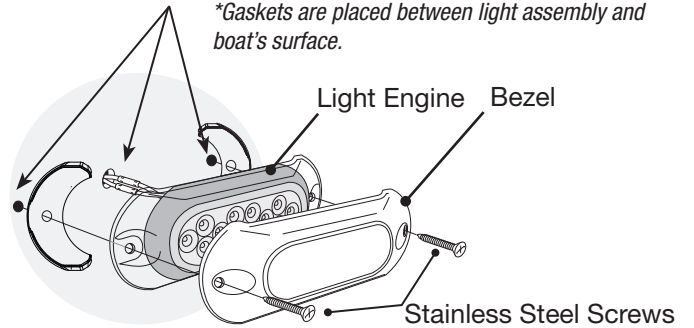

Figure 2

Add an additional "small" quantity of sealant around wire lead to help seal hole as installed.

Note: Keep sealant off cooling ribs. Failing to do so will affect the light's performance.

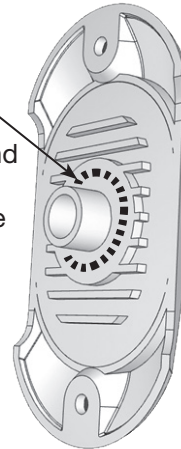
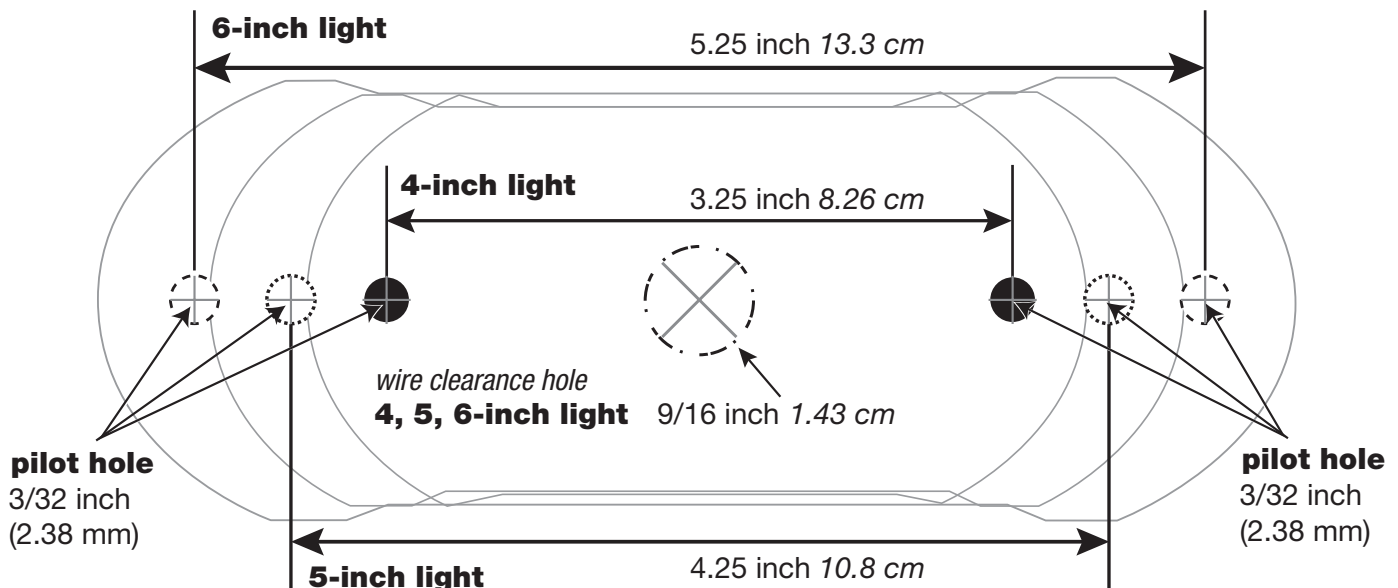
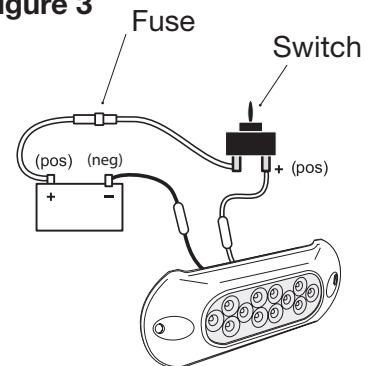

Figure 3



ATTWOOD LIMITED 10-YEAR WARRANTY

This product carries a limited ten (10) year warranty. This is a non-serviceable (LED) light source, any attempt to open or service the light voids the warranty.