



12-Volt Stainless 1-Mile Navigational Light

Without Wire Leads: 66320
With 7" Wire Leads: 66318, 66319

Attwood marine hardware, navigational lighting, bilge pumps, and other marine accessories are specified more than any other brand by America's best-known boat manufacturers as original equipment. Look to Attwood for quality replacement parts and marine accessories.

SAVE THESE INSTRUCTIONS

Form Number 69376

FEATURES

The Attwood 12-volt DC stainless steel one-mile navigational sidelights are designed for mounting on horizontal surfaces, such as the gunwale or deck. Meets USCG CFR 183.810, ABYC A-16 requirements, and all applicable standards as tested by ITS (ETL). 1 Nautical Mile visibility. Uses Lamp 9231, 12V, 8 Watt.

The housing is made of highly-polished stainless steel for corrosion resistance. The lens completely encapsulates the bulb and socket assembly for splash resistance. The lens rests on a rubber gasket, making these lights virtually waterproof when used with the optional base gasket.

REQUIRED FOR INSTALLATION

- #1 Phillips head screwdriver.
- Drill with suitable bits — 1/2" (13mm).
- Base gasket (Attwood # 910410) or marine sealant.
- Three #4 or #6 stainless steel pan head screws.

LOCATION

1. Be sure that sidelights shine straight ahead. Combination sidelight must be aligned on centerline (See Figure 1a), sidelights pairs must be parallel to centerline (See Figure 1b.)
2. Position light(s) on a horizontal surface ($\pm 5^\circ$) of the gunwale or deck. If installing a combination light, place it on the furthestmost tip of the bow on the centerline of the boat. (See Figure 1a.)

Sidelight pairs must be equal distance from the bow. The red lens must be on the port (left) and the green on the starboard (right) as you stand onboard facing the bow of the boat. (See Figure 1b.)

Figure 1a

Figure 1b

112.5° Arc Must Be Clear

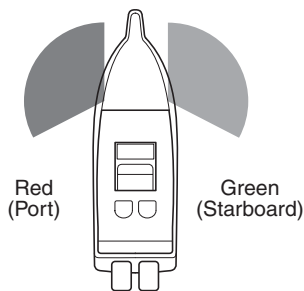
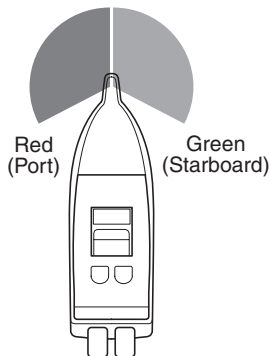

4. Measure and mark location of terminal clearance hole. Hole(s) must be on boat centerline for combination sidelight (66318, Figure 1a), or equal distance from bow for sidelight pairs (66320 and 66319, figure 1b.) Drill a 1/2" (13mm)-dia. hole. (See Figure 2.)

Figure 2

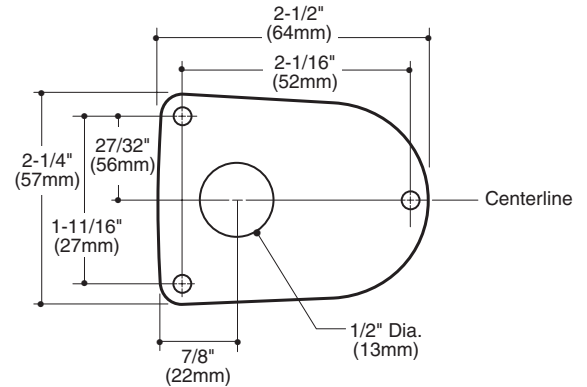

MOUNTING INSTRUCTIONS

1. Place base into hole and align so that light(s) shine straight ahead. Use base to mark pilot holes for the mounting screws. Drill pilot holes.
2. Feed the power source leads up through the deck and attach to base terminals or wires. Insulated terminals are recommended.
3. Apply base gasket or sealant to the deck mounting area. Gasket is highly recommended on aluminum surfaces. Place gasket, then lens, and housing over the base.

CAUTION

Position carefully on aluminum boats so that wires do not contact the hull.

4. Insert mounting screws through housing and fasten into deck. (See Figure 3.)

Figure 3

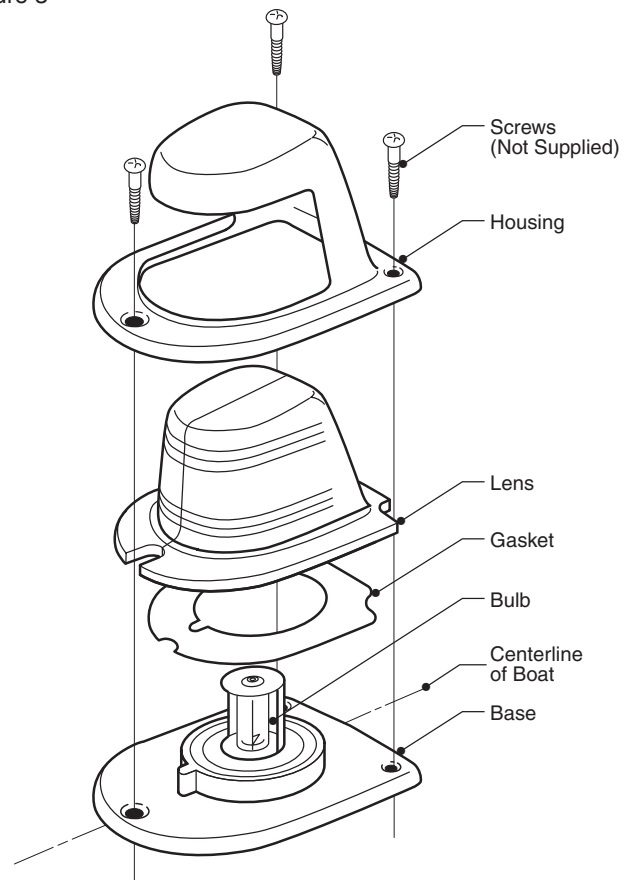

3. Ensure that there are no front or side obstructions, such as rail stanchions, chocks, anchors, etc., within the arc of visibility (112.5° each side).

WIRING INSTRUCTIONS

The power source must be 12-volt DC ONLY. Use marine grade wire connectors only. Protect all connections with suitable materials.

NOTE: Failure to make proper connections and fuse the light properly will void the product warranty.

1. Connect one terminal to the negative (-) post of the 12-volt battery. Connect the other terminal to the positive (+) lead through a 2-amp fuse and suitable dash-mounted switch. (See Figure 4.)

Figure 4

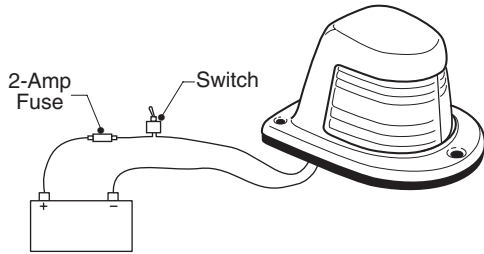

2. Test lights for proper operation from dash-mounted control switch.

MAINTENANCE

Replace bulb, when necessary, with standard 8-watt automotive festoon type (Attwood #9231).