



4" and 6" Flush Mounted Cleat

66510, 66511, 66512, 66513, 66514, 66516

Installation Instructions

SAVE THESE INSTRUCTIONS

Form Number 69343 Rev. G

APPLICATION

Attwood flush pull-up cleats provide easy fittings for mooring and anchoring applications.

NOTE: It is recommended that the installation of the Attwood Flush Cleats be done by a boat builder, boat dealer, or a qualified marine mechanic.

REQUIRED FOR INSTALLATION

- Adjustable wrench
- Length of 3/8" (9.5mm) I.D. hose
- Cordless drill and bits
- Sabre saw
- Screwdriver
- Marine sealant

WARNING:

To prevent personal injury, always disconnect the power source when installing or servicing this product. Always remove the boat from the water before using any 120V AC power tools.

LOCATION

Select an installation location that meets the following criteria:

- Location on vessel must be able to withstand loads specified in application section. See ABYC Reg. H-40 for details and ratings.
- Location is large enough and wide enough to accommodate the entire cleat body.
- Access to the underside of the vessel is necessary for both models in order to tighten the fasteners.

FLUSH CLEAT TEMPLATES

Figure 1

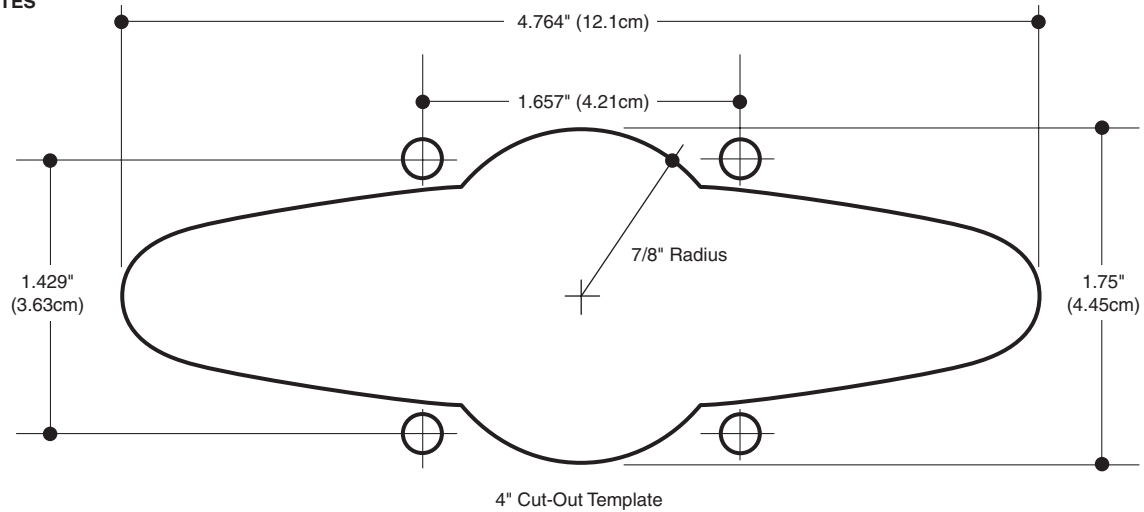
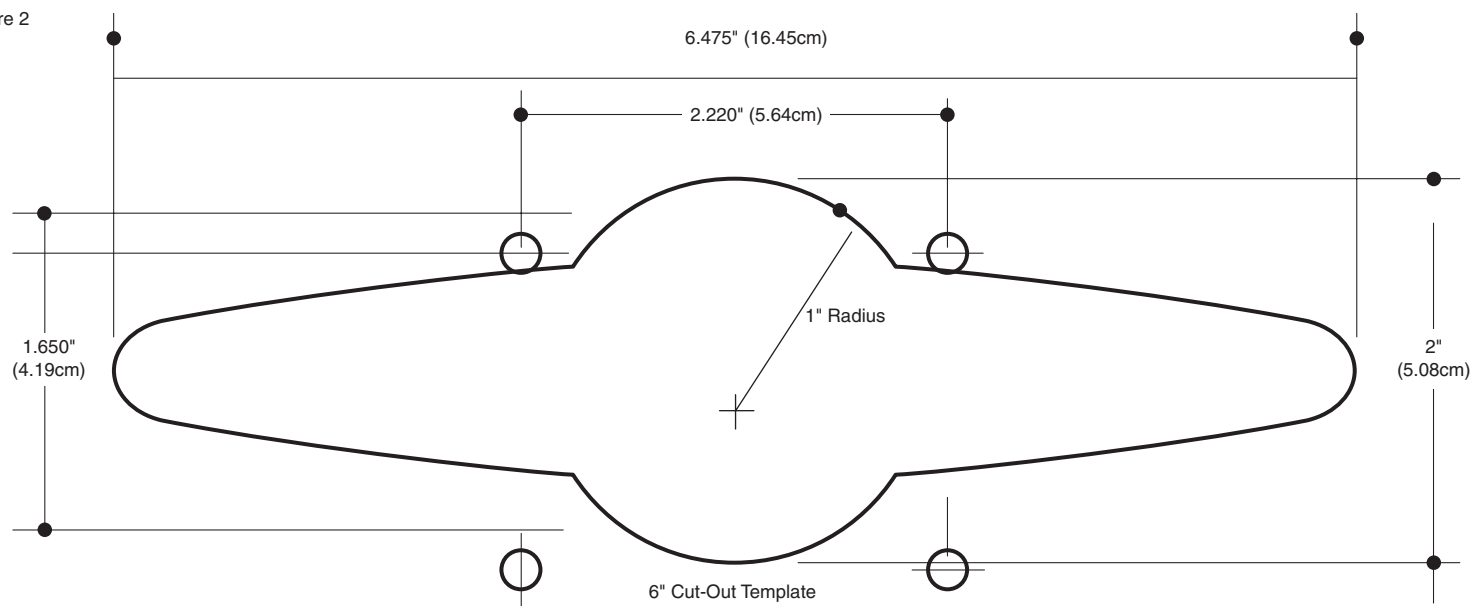

Figure 2



FLUSH CLEAT INSTALLATION INSTRUCTIONS

NOTE: Before you drill or cut a hole on your boat, BE ABSOLUTELY CERTAIN there is room for the unit beneath the deck or gunwale where it will be installed. The cleat mechanism, in the down position, will be recessed beneath the deck or gunwale.

1. Use templates provided to mark opening in deck (Figure 1 or 2). Cut using sabre saw and drill four 1/4" (6.4mm) holes where indicated (thru-bolt cleat only).
2. Remove the supplied fasteners from the studded cleat. Apply a small bead of marine sealant around the edge of the cut-out and place cleat in hole cut-out.
3. Align backing plate with the underside of the cleat. For the 4" thru-bolt version use (4) #10 machine screws, locking washers and nuts (regular washers and nylock nuts can be substituted). For the 6" thru-bolt version use (4) 1/4"-20 machine screws, locking washers and nuts (regular washers and nylock nuts can be substituted).
4. Ensure the screw is long enough to provide for proper engagement with the nut. Attach washers and nuts to the studs or screws and tighten.

WARNING:

The Flush Cleats are not to be used for towing, lifting, or for any other anchoring application beyond those listed above. Any misuse of the intended application may result in personal injury and/or damage to the boat.

OPTIONAL WATER RECEPTACLE INSTALLATION. (Water receptacle sold separately.)

If using the water receptacle on:

Thru-Bolt Version

The same cut-out can be used when the cleat is mounted with the receptacle.

1. Place water receptacle on underside of cleat and attach per flush cleat installation instructions (Figure 3). The screws used must be long enough to go through the flange of the cleat, deck, mounting plate and then the water receptacle.
2. Connect 3/8" inner diameter hose to the fitting on the receptacle. Route the hose into the bilge or to a drain fitting.

Figure 3

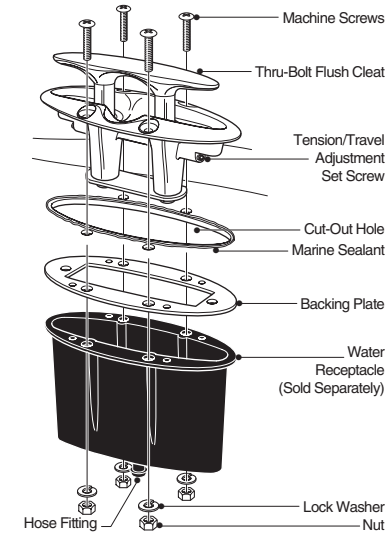

Studded Version

1. After the cleat has been installed, attach water receptacle to the backing plate using (4) #8 self-tapping screws (Figure 4).
2. Connect 3/8" inner diameter hose to the fitting on the water receptacle. Route hose into bilge or to a drain fitting.

Figure 4

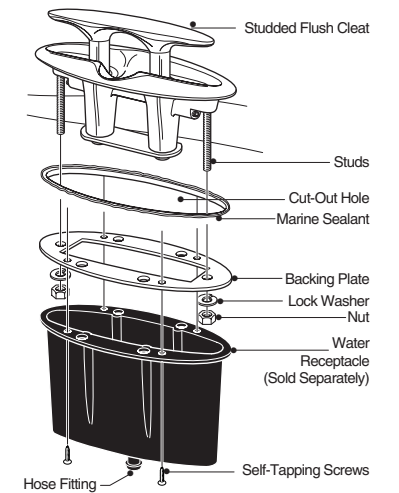

MAINTENANCE

- A silicone based lubricant maybe used on cleat shafts to increase the ease of travel.

Looking for dependable docking? Rely on Attwood for quality and long-lasting products.