



Stowaway Light Base

910R2, 910T2, 910V2
910R3, 910T3, 910V3

Installation Instructions

Attwood marine hardware, navigational lighting, bilge pumps, and other marine accessories are specified more than any other brand by America's best-known boat manufacturers as original equipment. Look to Attwood for quality replacement parts and marine accessories.

FEATURES

This base is designed for use with the Attwood locking collar poles (All-Around and Navigation lights). For 12-volt D.C. only.

CAUTION

To prevent personal injury, always disconnect the power source when installing or servicing this product. Always remove the boat from the water before using 120 VAC power tools.

Figure 1

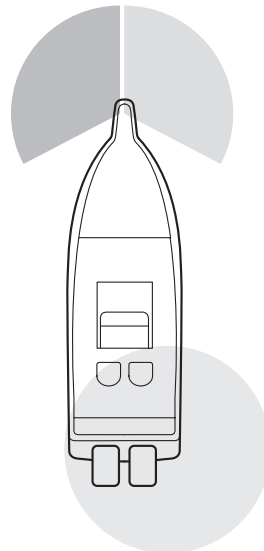

Note: For technical detailed positioning follow COLREG 72 or ABYC A-16. Figure 1 is a simplified drawing of placement of navigational lights in relationship to one another.

INSTALLATION INSTRUCTIONS

1. Position the light base either on the bow for combination sidelights or the stern or gunwale for all-round lights. Be sure that the mounting surface is flat and that the selected area will accommodate the base dimensions. Base angle and position must properly place light used in base.
2. Using the template provided (Figure 2), locate the base center line parallel to the boat fore-and-aft center line and carefully mark the center installation hole and the screw holes. Drill 1-1/8" diameter hole being very careful not to crack or break the gelcoat finish. Sand to remove burrs from around the edge of the hole. Drill the pilot screw holes.

Note: On some installations you may have to connect the wires then push them back through wire hole prior to screwing down the base.

3. Apply sealant between deck and light base. Fasten base in place with stainless steel screws.

CAUTION: Do not overtighten screws.

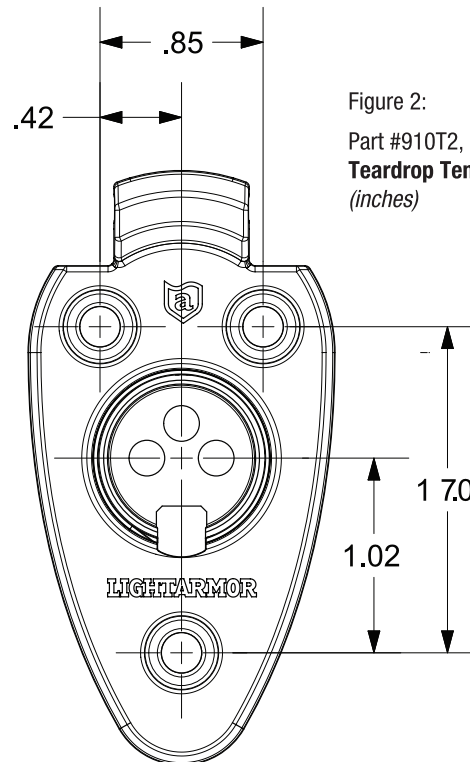

Figure 2:
Part #910T2, #910T3
Teardrop Template
(inches)

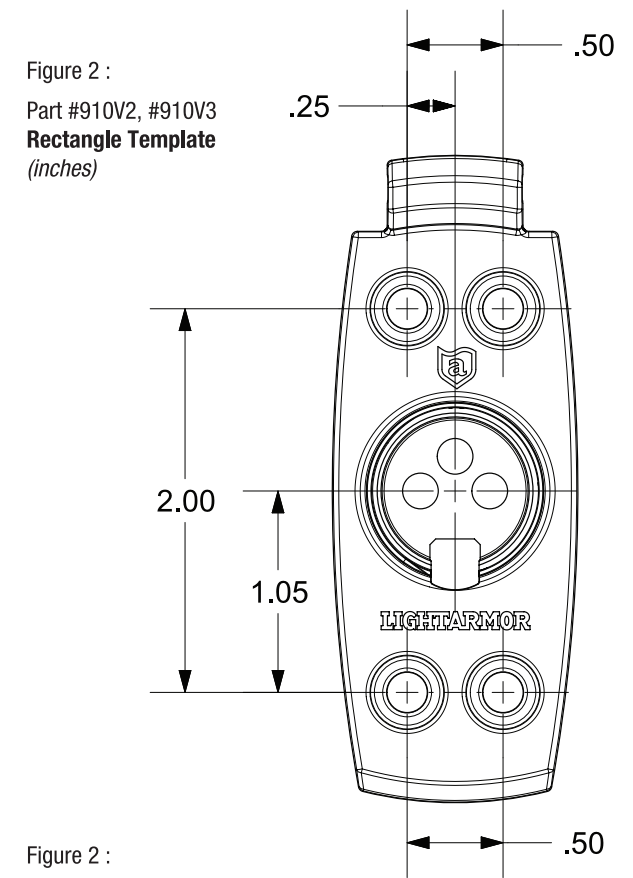

Figure 2 :
Part #910V2, #910V3
Rectangle Template
(inches)

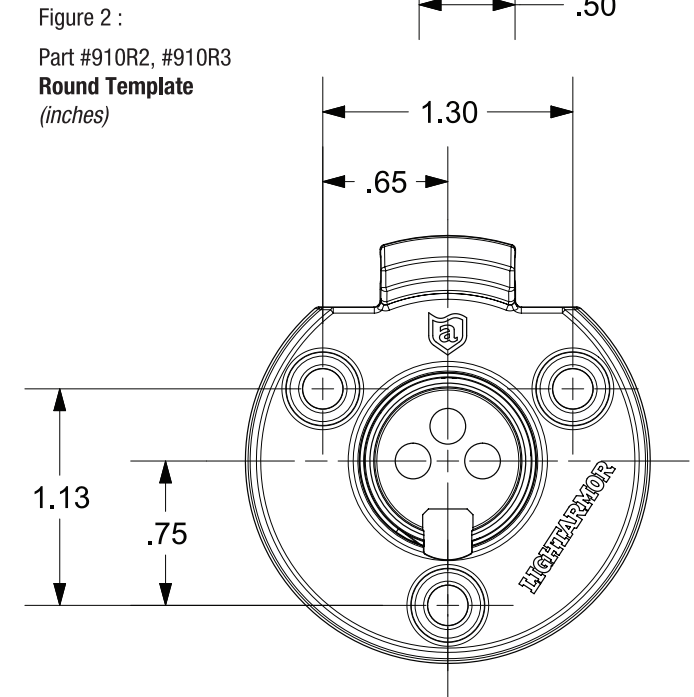

Figure 2 :
Part #910R2, #910R3
Round Template
(inches)

Part #910V2,
#910V3



Part #910T2,
#910T3



Part #910R2,
#910R3



FINAL WIRING FOR:

910R2, 910V2, 910T2 (2 wire base):

Connect the black wire to the battery ground (-) harness, using a crimp-on wire connector. Attach the remaining gray wire to the positive switched wire from the navigation light switch.

910R3, 910V3, 910T3 (3 wire base):

Connect black wire to the battery ground (-) harness, using a wire connector. Connect the blue wire to the wire from the switch for the courtesy light. Use a wire connector to make the connection. Connect the gray wire to the wire from the switch for the navigation running lights using a wire connector.

All positive wires must be fused according to light specs to protect the circuit. **MAKE SURE POWER SOURCE IS 12-VOLT D.C. ONLY.**

HIGHER VOLTAGE CAN CAUSE DAMAGE TO LIGHT AND WIRE CIRCUITRY.

Insert light pole into base and press down to make contact. Insert locking collar into base opening, rotate if necessary to push it down into base. Rotate collar until tight to hold light pole in base. Test light operation. Remove and stow light. Close cover to protect contacts when not in use.