



PRESSURE RELIEF SYSTEM DECK FILL

99DFPV Series

INSTALLATION INSTRUCTIONS
SAVE THESE INSTRUCTIONS

11/04

69485 Rev. B

CAUTION:

The vessel manufacturer must comply with the requirements of CFR 40 1060.202.

Failure to follow these instructions may result in accidental fuel system over-pressurization. Users must follow these instructions to ensure vessel function and operation

EMISSION-RELATED INSTALLATION INSTRUCTIONS

Failing to follow these instructions when installing the Attwood Pressure Relief System Deck Fills in a piece of nonroad equipment violates federal law (40 CFR 1068.105(b)), subject to fines or other penalties as described in the Clean Air Act.

FEATURES:

Attwood Pressure Relief System Deck Fills are sturdy, non-corrosive plastic. Bonding and grounding are not required because they are non-metallic. When latched, Deck Fills are water-resistant. They meet all requirements for ISO 10080, ABYC, and USCG.

WARNING! The use of Attwood 99DFPV Series Deck Fills will result in a pressurized fuel system designed to meet the diurnal emission requirements of CFR 40. Care must be taken to prevent pressurized fuel from reaching flexible fuel distribution lines and/or engine. Pressurized fuel may cause engine operation issues. See engine manufacturer's instructions. Install the Attwood 99IFDV Series Fuel Demand Valve on the fuel tank in order to prevent pressurized fuel from exiting fuel tank.

REQUIRED FOR INSTALLATION

- Pencil
- Drill
- 1-1/4" (32mm) bit or hole saw
- 2-1/4" (57mm) dia. hole saw (see Figure 1)
- Drill bit for fastener pilot holes — 3/32" (2.4mm) to 3/16" (5mm) depending on deck material
- (4) #8 stainless steel fasteners appropriate for specific deck material
- File for smoothing holes
- Screwdriver
- Marine-grade urethane-based sealant (Attwood #30106-6 recommended, **DO NOT USE A SILICONE-BASED SEALANT**)
- 1-1/2" (38mm) I.D. fill hose
- 5/8" (16mm) I.D. vent hose
- Stainless Steel clamps to match hose diameters

MOUNTING LOCATION AND REGULATIONS

Select location that meets these conditions:

1. Conforms to all ABYC, U.S. Coast Guard, and EPA regulations. (See end of this document for information availability.)
2. Surface must be flat, in an area where spilled fuel cannot enter the boat.
3. Below-deck area must allow adequate clearance to install and route hose(s) to the tank and should also all for predominantly vertical orientation of the fill hose.
4. Fill and vent hose installation must meet regulations — A.B.Y.C and U.S. Coast Guard Safety Standards for Small Boat Fuel Systems (33 CFR 183).
5. Deck thickness must be 1/2" (13mm) or less.
6. Straight Deck Fills *cannot* be mounted on a vertical surface +/- 30°. Angled Deck Fills *can* be mounted on a vertical surface right side up with hinge on top +/- 15°.

INSTALLATION INSTRUCTIONS

1. Cut out and orient mounting template (Figure 1) to match final position of Deck Fill. Attach template to deck.

- Note:** Deck Fill should be oriented to allow for standard fuel nozzles to be correctly inserted at the pump.
2. Mark and drill pilot hole positions for large and small holes.
 3. Remove template. Drill 1-1/4" dia. (32mm) hole first. Drill 2-1/4" (57mm) hole. Use file to remove burrs and deck material between holes.
 4. "Dry Fit" the Deck Fill neck into hole. (Figure 2)
 5. Mark position and drill small pilot holes for deck fasteners (fasteners not provided).
 6. Remove Deck Fill Neck. Apply a thin bead of marine-grade, urethane-based sealant (Attwood #30106-6 recommended) to underside of the Deck Fill.
 7. Press Deck Fill neck into hole.
 8. Fasten Deck Fill with #8 screws appropriate for the deck material (fasteners not provided). Torque to 30 +/- 3 in-lb. Do not overtorque.
 9. Clean any sealant spilled around Deck Fill edges.
 10. Attach and clamp 1-1/2" (38mm) fill hose using two (2) clamps. Use corrosion-resistant metallic clamps with nominal band widths of at least 1/2" (12mm). The first clamp should be 1/4" (6mm) from the end of the hose. The second hose clamp should be located above the barb leaving a small gap (at least 1/4") between the clamps. Torque to 36 +/- 4 in-lb.
 11. Attach and clamp 5/8" (16mm) maximum vent hose using at least one (1) corrosion-resistant metallic clamp with nominal band width of at least 5/16" (8mm). Torque hose clamp to 36 +/- 4 in-lb.
 12. Attach and clamp 5/8" vent hose using one (1) clamp. Torque hose clamp to 36 +/- 4 in-lb. Ensure 5/8" vent hose connects with 5/8" port on 99FL Series vent valves.
 13. Leak test installed deck fill per USCG CFR 33 183.580 at pressure of 3 psi for no less than 10 minutes. Inspect all connections for leaks by a method other than pressure decay.

Important safety instructions (for all Attwood 99FL/99GV/99CC/99ICV/99DF components):

When a fuel system is configured with Attwood 99DFPV Series Deck Fills, the following safety precautions must be taken;

1. Use an Attwood 99ICV series Inlet Control valve between the liquid reservoir and the deckfill to prevent the accidental wellback of fuel. Use only an Attwood 99ICV series Inlet Control Valve in-line with the fuel fill hose. No other fill hose valves should be installed in order to ensure the safety of the fuel system and vessel. The Attwood 99ICV series inlet control valves includes features to allow vapor and liquid to pass the valve in order to ensure the system does not become accidentally over pressurized.
2. Install an Attwood 99FL Series Fill Limit Vent Valve in the vent line between the liquid reservoir and the deck fill vent in order to prevent the accidental wellback of fuel.
3. Install an Attwood 99IFDV Series Integrated Fuel Demand Valve in fuel distribution line to prevent tank pressure from pressurizing fuel line.

CARE AND MAINTENANCE

Care should be taken, when cleaning the boat, to prevent contaminating the valves and deckfill. Cleaning with only mild soapy water is recommended. All connections should be checked annually.

MANUFACTURER REQUIREMENTS

The information below applies only to EPA CFR 40 1060.135. The vessel manufacturer is responsible to meet all additional regulatory labeling requirements including EPA, CARB, USCG and others as necessary. The below information is for reference only. The vessel manufacturer should refer to CFR 40 for complete labeling guidelines.

In order to meet the requirements of CFR 40 1060.135, the vessel must be labeled with respect to evaporative emissions in the following manner when installing certified components;

Excerpt from CFR 40 1060.135

(a) You must affix a permanent and legible label identifying each engine or piece of equipment before introducing it into U.S. commerce. The label must be—

- (1) Attached in one piece so it is not removable without being destroyed or defaced.
- (2) Secured to a part of the engine or equipment needed for normal operation and not normally requiring replacement.
- (3) Durable and readable for the equipment's entire life.
- (4) Written in English.
- (5) Readily visible in the final installation. It may be under a hinged door or other readily opened cover. It may not be hidden by any cover attached with screws or any similar designs. Labels on marine vessels must be visible from the helm.

(c) If you produce equipment without certifying with respect to evaporative emissions, the equipment label specified in paragraph (a) of this section must—

- (1) State: "MEETS U.S. EPA EVAP STANDARDS USING CERTIFIED COMPONENTS."
- (2) Include your corporate name.

Below is an example of a label specified by CFR40 1060.135 for use with certified components;

**MEETS U.S. EPA EVAP STANDARDS USING
CERTIFIED COMPONENTS
CORPORATE NAME**

Please refer to CFR 40 1060.135 to review EPA vessel labeling requirements. The NMMA has a program to supply OEM builders with labels. Please refer to the NMMA website below for further information regarding the NMMA label program

FIGURE 1 - MOUNTING TEMPLATE

Cut out and orient to match final position of Deck Fill

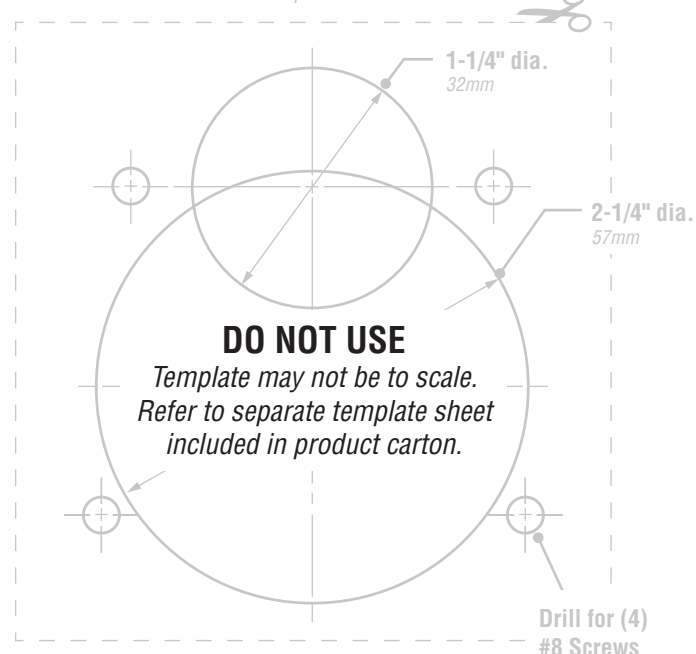

FIGURE 2

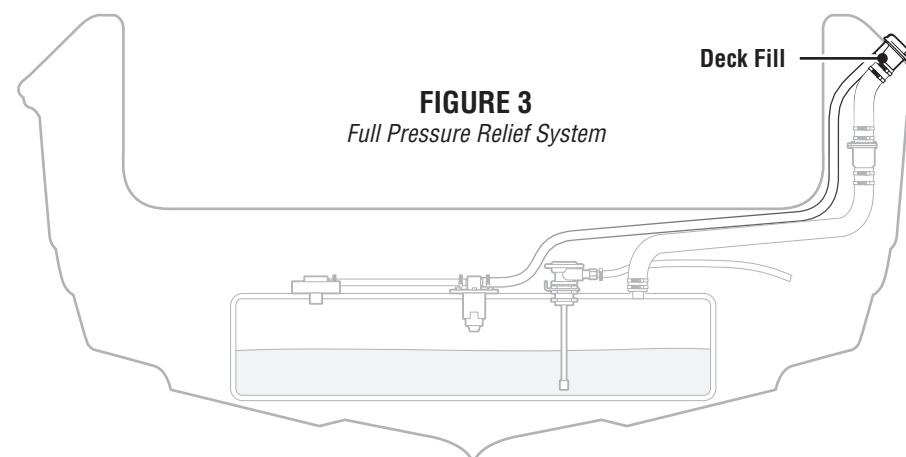
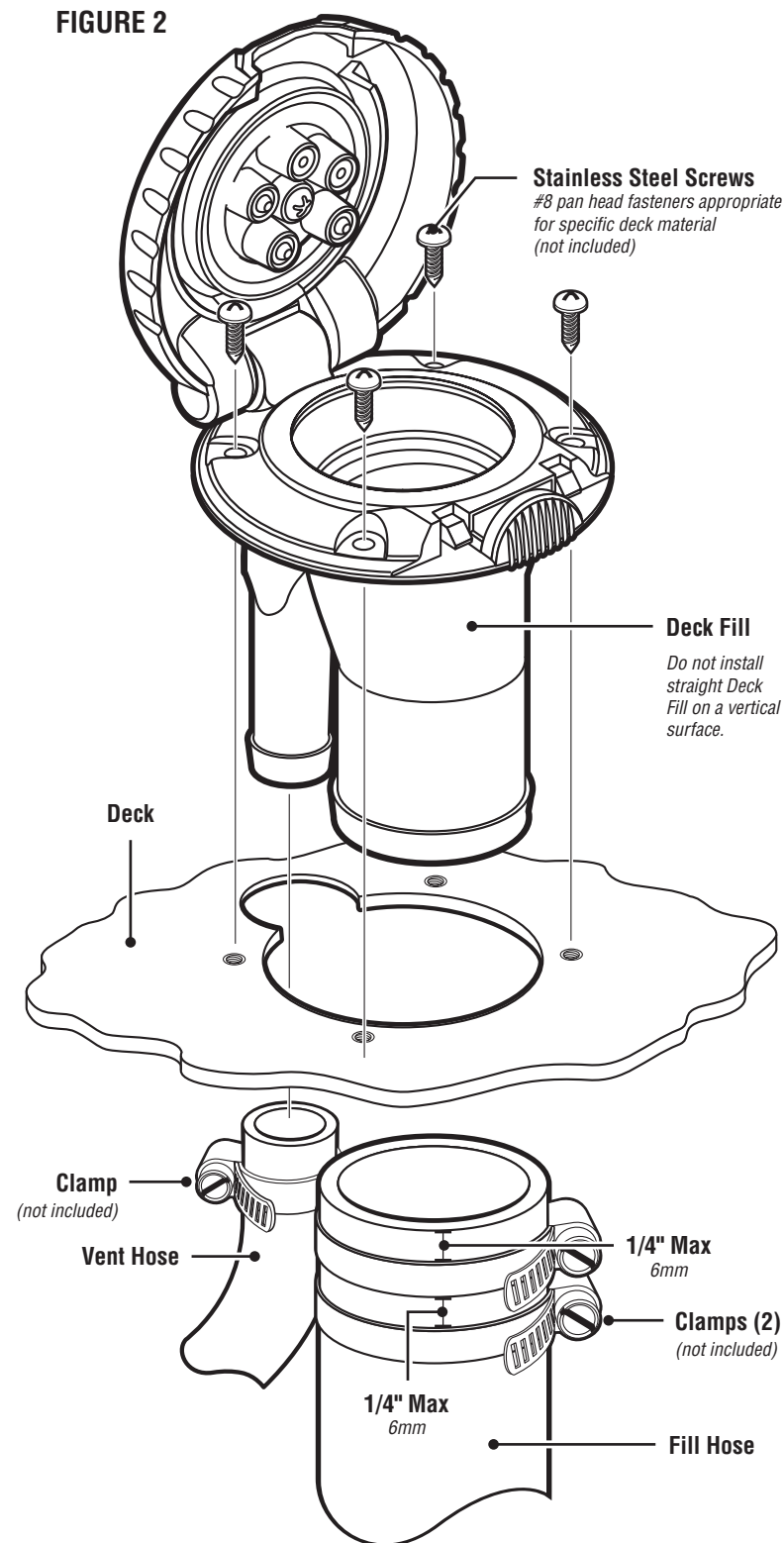

FIGURE 3
Full Pressure Relief System

©2011 Attwood Corporation

Learn more about boat on deck and outdoor we have.