



# Anti-Glare All-Round Light

5300, 5310, or 5320 Series: Fixed Head  
5330 Series: Articulating Head  
Installation Instructions

## SAVE THESE INSTRUCTIONS

Form Number 69388 Rev. A

03-02

Lights meet USCG CFR 183.810, ABYC A-16 requirements, and all applicable standards as tested by Imanna Labs, 7/19/2002. 2 Nautical Mile visibility. Use Lamp 9235, #906 13V, 6 Candle Power.

### CAUTION:

Read all instructions carefully before installing and using this product.

All positive (+12V DC) lighting wires require a 1-amp fuse to protect circuits and vessel. The aluminum light pole is not grounded. **MAKE SURE POWER SOURCE IS 12-VOLT DC ONLY. HIGHER VOLTAGE WILL DAMAGE LIGHT AND CIRCUITRY.**

### WARNING:

To prevent injury, disconnect power when installing or servicing this product. Remove boat from water before using any 120V AC power tools.

### LOCATION

Anti-Glare All-Round Lights are designed for boats up to 39.4 feet (12m). Position the Anti-Glare All-Round Light so bulb is not less than one meter (39.4") above sidelights. If replacing an existing pole light, replace with a pole at least as long as the existing.

Mount the anti-glare light in a position so that:

- Light output is flat and parallel to water when boat is floating.
- Light shines 360°, unobstructed.
- Light does not shine on operator, or reflect off any part of the boat in the operator's field of vision.

Figure 1

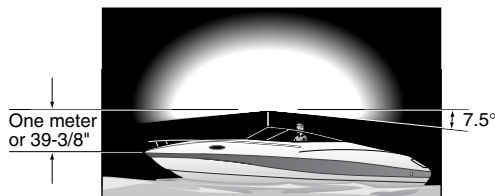

### INSTALLATION

Figure 2

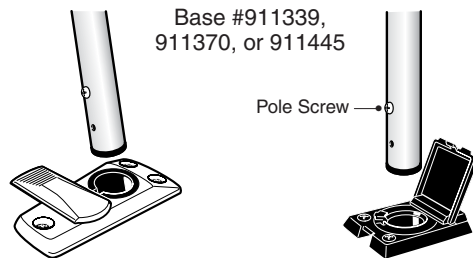

#### Poles Without Locking Collar (5300 Series)

1. Align pole screw with slot in the existing base. Insert pole into base (Figure 2).
2. Press down firmly to engage electrical connectors.
3. To remove, pull straight up.

#### Poles With Locking Collar (5310, 5320, 5330 Series)

1. Align pole screw with slot in the existing base. Insert pole into base (Figure 3).
2. Press down firmly to engage electrical connectors.
3. Slide locking collar down to base, rotate until you can insert lower ring inside top of base.
4. Press collar down into base and rotate until it tightens between pole and base.

**NOTE:** Periodically check pole to make sure it is secure.

5. To remove light, rotate locking collar in opposite direction until it loosens, then pull up on pole. (Figure 3)

Figure 3

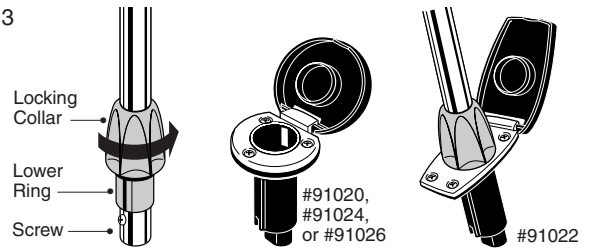

#### TO CONVERT POLE FOR USE WITHOUT LOCKING COLLAR

1. For bases that do not accept locking collar, remove screw at bottom of pole. Slide locking collar off end of pole.
2. Replace screw in the upper screw hole.

#### TO ADJUST ANTI-GLARE ARTICULATING HEAD (5330 Series)

For best glare reduction, adjust the light while the boat is floating, or at the same attitude as if it were floating.

1. Unscrew lens counter-clockwise and remove. Remove bulb (Figure 4)
2. Remove the pivot screw. Pull the top pivot up and away from yoke. Place a small level on top of the socket and rotate to level position.
3. When it is level, push yoke and pivot back together. Replace and tighten screw. (Do not over tighten.) Replace bulb.

Figure 4

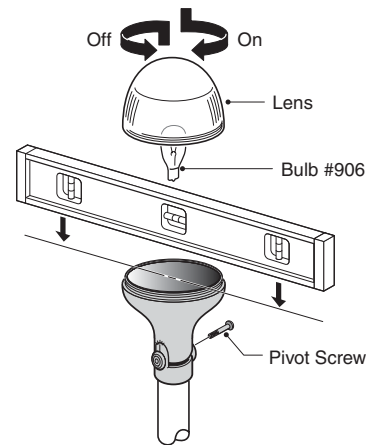

### OPERATION

After installation, check lights to verify proper operation. Regulations require lights to be operated with a three-position switch for:

- Running lights (sidelights and all-round light); Anchor lights (all-round light only); Off.

**NOTE:** Do not use light pole as a flagpole or handle.

### MAINTENANCE

When not in use, store in Pole Light Storage Clips (Attwood 7571). Choose a storage location where light will not be damaged or be in constant contact with water.

#### Replacing Bulb

1. Unscrew lens counter-clockwise and remove. Pull bulb straight up (Figure 4)
2. Replace bulb with #906 9-Watt Wedge Base Replacement Bulb (Attwood 9235-7) available in marine, auto, and convenience stores.
3. Screw lens clockwise onto pole.
4. If lens requires replacement, order Attwood #912852.

Clean the light with a mild soap and warm water solution. Never use solvents or abrasives that may damage the lens or light housing.