



NV1010 SERIES

1 NM AND 2 NM NAVIGATION LIGHTS SIDELIGHT, LED, PAIR

SAVE THESE INSTRUCTIONS
Form number 69573

1 NM SIDELIGHTS

- For boats up to 12 meters / 39.4 feet in length.
- Meets USCG CFR 183.810, ABYC A-16 and all applicable standards as tested by Imanna Laboratories and ISO19009 requirements.
- 1 nautical mile visibility.

2 NM SIDELIGHTS

- For boats up to 20 meters / 65.6 feet in length.
- Meets USCG CFR 183.810, ABYC A-16 and all applicable standards as tested by Imanna Laboratories and ISO19009 requirements.
- 2 nautical mile visibility.

REQUIRED FOR INSTALLATION

- Phillips screwdriver
- Drill
- 3/8 inch drill bit for wire clearance hole
- #29 drill bit for pilot holes for mounting screws
- Six #8 pan head stainless steel screws for mounting (not provided)

LOCATION

1. Position light(s) on a surface of the gunwale or deck that is horizontal (within $\pm 5^\circ$).
2. As you stand onboard facing bow of the boat, place red light on the port (left) and the green light on the starboard (right). Lights must be parallel to center line of the boat (See Figure 1).
3. Make sure there are no obstructions such as rail stanchions, chocks, anchors, cleats, etc..

DRILLING INSTRUCTIONS / MOUNTING

1. Using gasket as template, mark location of wire clearance hole. At the marked location, drill a 3/8 inch hole.
CAUTION Position holes carefully on aluminum boats so that wires do not contact the hull.
2. Wipe away debris caused by drilling.
3. Feed wires through gasket and drilled hole and position housing so that arrow on gasket is pointing toward bow ($\pm 5^\circ$).
4. Drill 3 pilot holes for each light using #29 drill bit.
5. Insert #8 stainless steel mounting screws through housing to fasten to the deck. (Three per light.) Tighten until gasket seals to the deck.
NOTE: If area below the light will not be reachable after installation, attach a suitable length of 16-gauge red- and black-colored NON-POWERED wire that can be routed to an accessible area.
6. Make connections according to WIRING INSTRUCTIONS (Figure 3).
7. To attach cover, align the bottom edge of the cover to the back edge of the housing with the cover at a 45 degree angle (Figure 4).
8. Apply downward force on the top of the cover making sure the front tab clears the front of the housing.
9. Make sure the tab interfaces with the slot in the housing once the cover is all the way down.
10. Fasten cover with assembly screw (provided).

WIRING INSTRUCTIONS

- The power supply must be 12-volt DC only.
- Use crimp-type marine-grade connectors with suitable waterproof insulation.
- Protect all connections with suitable materials.

NOTE: Failure to make proper connections and fuse the light properly will void the product warranty.

CAUTION Polarity is important. If wiring is connected wrong the LED light will not operate.

1. Connect wires to fused power source: (See Figure 3).
 - Connect the (-) black wire to the negative (-) wire from the 12-volt supply.
 - Connect the (+) gray or red wire along with proper fuse and switch to the positive (+) 12-volt supply.
 - Fuse must be 1-amp.
2. Navigation rules require sidelights to be operated separately from anchor lights. Use either two switches or one switch with three positions for off/anchor/running.

Figure 1

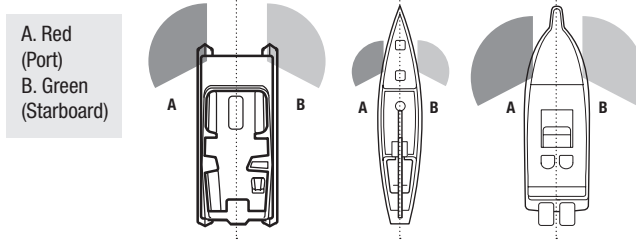

Figure 2

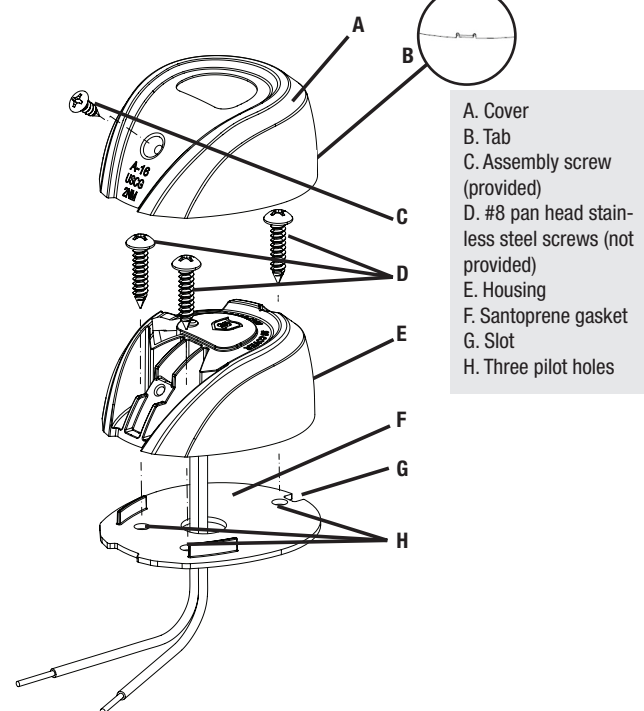

Figure 3

- A. 1-Amp Fuse
- B. Switch
- C. (pos)
- D. (neg)
- E. 12 V DC
- F. Green (Starboard)
- G. Red (Port)

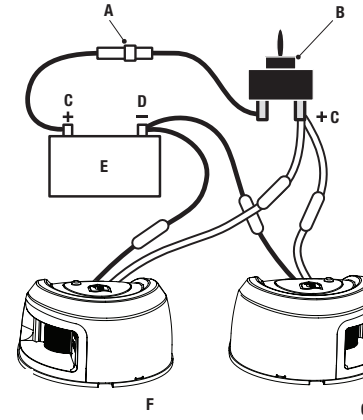
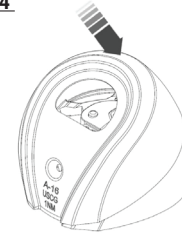

Figure 4





NV1000 SERIES

1 NM AND 2 NM NAVIGATION LIGHTS BI-COLOR COMBO, LED

SAVE THESE INSTRUCTIONS

Form number 69574 Rev. A

12/2016

1 NM BI-COLOR COMBINATION BOW LIGHT

- For boats up to 12 meters / 39.4 feet in length.
- Meets USCG CFR 183.810, ABYC A-16 and all applicable standards as tested by Imanna Laboratories and ISO19009 requirements.
- 1 nautical mile visibility.

2 NM BI-COLOR COMBINATION BOW LIGHT

- For boats up to 20 meters / 65.6 feet in length.
- Meets USCG CFR 183.810, ABYC A-16 and all applicable standards as tested by Imanna Laboratories and ISO19009 requirements.
- 2 nautical mile visibility.

REQUIRED FOR INSTALLATION

- Phillips screwdriver
- Drill
- 3/8 inch drill bit for wire clearance hole
- #29 drill bit for pilot holes for mounting screws
- Three #8 pan head stainless steel screws for mounting (not provided)

LOCATION

1. Position light(s) on a surface of the gunwale or deck that is horizontal (within $\pm 5^\circ$).
2. When installing bi-color combination light, place it on the centerline of the bow of the boat. (See Figure 1).
3. Make sure there are no obstructions such as rail stanchions, chocks, anchors, cleats, etc..

DRILLING INSTRUCTIONS / MOUNTING

1. Using the gasket as a template, mark location of wire clearance hole. At the marked location, drill a 3/8 inch hole.
CAUTION Position holes carefully on aluminum boats so that wires do not contact the hull.
2. Wipe away debris caused by drilling.
3. Feed wires through gasket and drilled hole / below deck and position housing so that arrow on gasket is pointing toward bow ($\pm 5^\circ$).
4. Drill 3 pilot holes for each light using #29 drill bit.
5. Insert #8 stainless steel mounting screws through housing to fasten to the deck. (Three per light.) Tighten until gasket seals to the deck.
NOTE: If area below the light will not be reachable after installation, attach a suitable length of 16-gauge red- and black-colored NON-POWERED wire that can be routed to an accessible area.
6. Make connections according to WIRING INSTRUCTIONS (Figure 3).
7. Align cover so that the tab fits inside the groove in housing and press firmly to snap in. Fasten cover with Philips head screw (provided).

WIRING INSTRUCTIONS

- The power supply must be 12-volt DC only.
- Use crimp-type marine-grade connectors with suitable waterproof insulation.
- Protect all connections with suitable materials.

NOTE: Failure to make proper connections and fuse the light properly will void the product warranty.

CAUTION Polarity is important. If wiring is connected wrong the LED light will not operate.

1. Connect wires to fused power source: (See Figure 3).
 - Connect the (-) black wire to the negative (-) wire from the 12-volt supply.
 - Connect the (+) gray or red wire along with proper fuse and switch to the positive (+) 12-volt supply.
 - Fuse must be 1-amp.
2. Navigation rules require sidelights to be operated separately from anchor lights. Use either two switches or one switch with three positions for off/anchor/running.

Figure 1

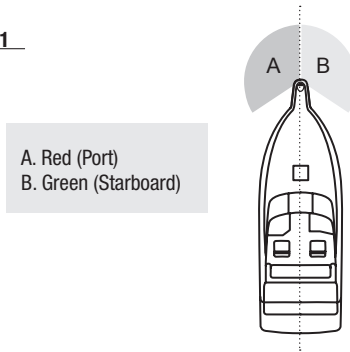

- A. Red (Port)
- B. Green (Starboard)

Figure 2

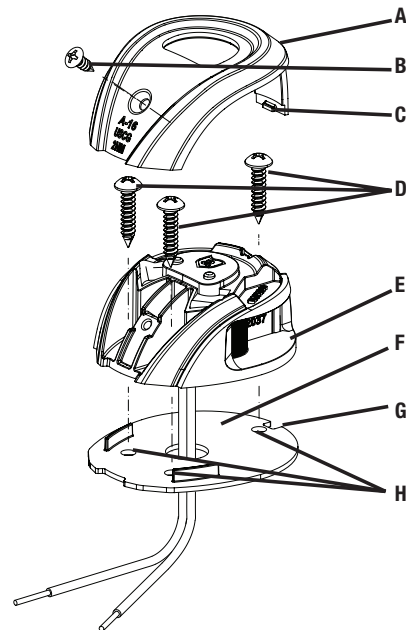

- A. Cover
- B. Assembly screw (provided)
- C. Tab
- D. #8 pan head stainless steel screws (not provided)
- E. Housing
- F. Santoprene gasket
- G. Slot
- H. Three pilot holes

Figure 3

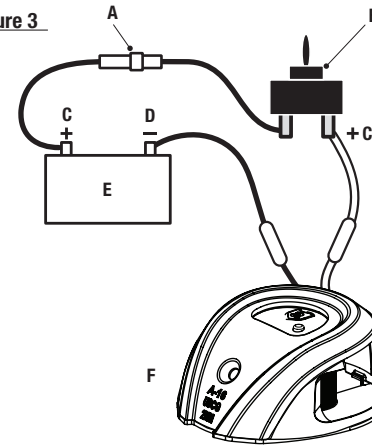

- A. 1-Amp Fuse
- B. Switch
- C. (pos)
- D. (neg)
- E. 12 V DC
- F. Bi-Color light



NV2010 SERIES

1 NM AND 2 NM NAVIGATION LIGHTS SIDELIGHT, LED, PAIR

SAVE THESE INSTRUCTIONS
Form number 69575 Rev. A

12/2016

1 NM SIDELIGHTS

- For boats up to 12 meters / 39.4 feet in length.
- Meets USCG CFR 183.810, ABYC A-16 and all applicable standards as tested by Imanna Laboratories and ISO19009 requirements.
- 1 nautical mile visibility.

2 NM SIDELIGHTS

- For boats up to 20 meters / 65.6 feet in length.
- Meets USCG CFR 183.810, ABYC A-16 and all applicable standards as tested by Imanna Laboratories and ISO19009 requirements.
- 2 nautical mile visibility.

REQUIRED FOR INSTALLATION

- Phillips screwdriver
- Drill
- 3/8 inch drill bit for wire clearance hole
- #29 drill bit for pilot holes for mounting screws
- Six #8 pan head stainless steel screws for mounting (not provided)

LOCATION

1. Position light(s) on a surface of the gunwale or deck that is horizontal (within $\pm 5^\circ$).
2. As you stand onboard facing bow of the boat, place red light on the port (left) and the green light on the starboard (right). Lights must be parallel to center line of the boat (See Figure 1).
3. Make sure there are no obstructions such as rail stanchions, chocks, anchors, cleats, etc..

DRILLING INSTRUCTIONS / MOUNTING

1. Using gasket as template, mark location of wire clearance hole. At the marked location, drill a 3/8 inch hole.
CAUTION Position holes carefully on aluminum boats so that wires do not contact the hull.
2. Wipe away debris caused by drilling.
3. Feed wires through gasket and drilled hole and position housing so that arrow on gasket is pointing toward bow ($\pm 5^\circ$).
4. Drill 3 pilot holes for each light using #29 drill bit.
5. Insert #8 stainless steel mounting screws through housing to fasten to the deck. (Three per light.) Tighten until gasket seals to the deck.
NOTE: If area below the light will not be reachable after installation, attach a suitable length of 16-gauge red- and black-colored NON-POWERED wire that can be routed to an accessible area.
6. Make connections according to WIRING INSTRUCTIONS (Figure 3).
7. To attach cover, align the bottom edge of the cover to the back edge of the housing with the cover at a 45 degree angle (Figure 4).
8. Apply downward force on the top of the cover making sure the front tab clears the front of the housing.
9. Make sure the tab interfaces with the slot in the housing once the cover is all the way down.
10. Fasten cover with assembly screw (provided).

WIRING INSTRUCTIONS (FIGURE 3)

- The power supply must be 12-volt DC only.
- Use crimp-type marine-grade connectors with suitable waterproof insulation.
- Protect all connections with suitable materials.

NOTE: Failure to make proper connections and fuse the light properly will void the product warranty.

CAUTION Polarity is important. If wiring is connected wrong the LED light will not operate.

1. Connect wires to fused power source: (See Figure 3).
 - Connect the (-) black wire to the negative (-) wire from the 12-volt supply.
 - Connect the (+) gray or red wire along with proper fuse and switch to the positive (+) 12-volt supply.
 - Fuse must be 1-amp.
2. Navigation rules require sidelights to be operated separately from anchor lights. Use either two switches or one switch with three positions for off/anchor/running.

Figure 1

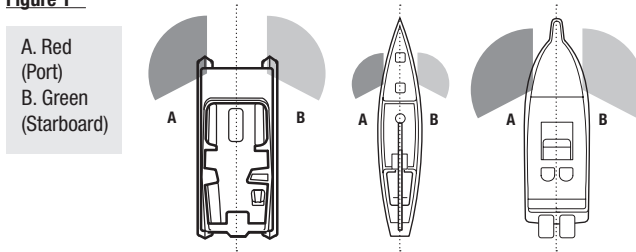

- A. Red (Port)
- B. Green (Starboard)

Figure 2

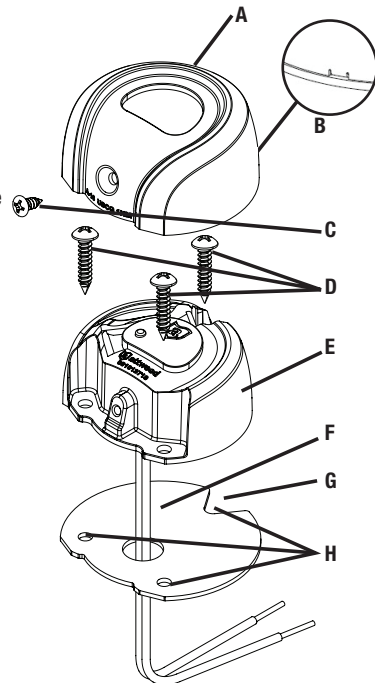

- A. Cover
- B. Tab
- C. Assembly screw (provided)
- D. #8 pan head stainless steel screws (not provided)
- E. Housing
- F. Santoprene gasket
- G. Slot
- H. Three pilot holes

Figure 3

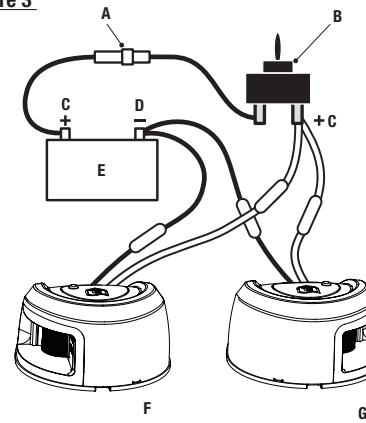

- A. 1-Amp Fuse
- B. Switch
- C. (pos)
- D. (neg)
- E. 12 V DC
- F. Green (Starboard)
- G. Red (Port)

Figure 4

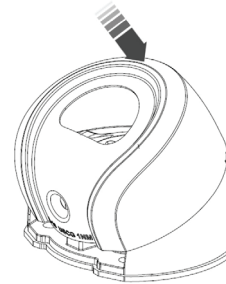



NV2000 SERIES

1 NM AND 2 NM NAVIGATION LIGHTS BI-COLOR COMBO, LED

SAVE THESE INSTRUCTIONS

Form number 69576 Rev. A

12/2016

1 NM BI-COLOR COMBINATION BOW LIGHT

- For boats up to 12 meters / 39.4 feet in length.
- Meets USCG CFR 183.810, ABYC A-16 and all applicable standards as tested by Imanna Laboratories and ISO19009 requirements.
- 1 nautical mile visibility.

2 NM BI-COLOR COMBINATION BOW LIGHT

- For boats up to 20 meters / 65.6 feet in length.
- Meets USCG CFR 183.810, ABYC A-16 and all applicable standards as tested by Imanna Laboratories and ISO19009 requirements.
- 2 nautical mile visibility.

REQUIRED FOR INSTALLATION

- Phillips screwdriver
- Drill
- 3/8 inch drill bit for wire clearance hole
- #29 drill bit for pilot holes for mounting screws
- Six #8 pan head stainless steel screws for mounting (not provided)

LOCATION

1. Position light(s) on a surface of the gunwale or deck that is horizontal (within $\pm 5^\circ$).
2. When installing bi-color combination light, place it on the centerline of the bow of the boat. (See Figure 1).
3. Make sure there are no obstructions such as rail stanchions, chocks, anchors, cleats, etc..

DRILLING INSTRUCTIONS / MOUNTING

1. Using the gasket as a template, mark location of wire clearance hole. At the marked location, drill a 3/8 inch hole.
CAUTION Position holes carefully on aluminum boats so that wires do not contact the hull.
2. Wipe away debris caused by drilling.
3. Feed wires through gasket and drilled hole / below deck and position housing so that arrow on gasket is pointing toward bow ($\pm 5^\circ$).
4. Drill 3 pilot holes for each light using #29 drill bit.
5. Insert #8 stainless steel mounting screws through housing to fasten to the deck. (Three per light.) Tighten until gasket seals to the deck.
NOTE: If area below the light will not be reachable after installation, attach a suitable length of 16-gauge red- and black-colored NON-POWERED wire that can be routed to an accessible area.
6. Make connections according to WIRING INSTRUCTIONS.
7. Align cover so that the tab fits inside groove in housing and press firmly to snap in. Fasten cover with philips head screw (provided).

WIRING INSTRUCTIONS

- The power supply must be 12-volt DC only.
- Use crimp-type marine-grade connectors with suitable waterproof insulation.
- Protect all connections with suitable materials.

NOTE: Failure to make proper connections and fuse the light properly will void the product warranty.

CAUTION Polarity is important. If wiring is connected wrong the LED light will not operate.

1. Connect wires to fused power source: (See Figure 3).
 - Connect the (-) black wire to the negative (-) wire from the 12-volt supply.
 - Connect the (+) gray or red wire along with proper fuse and switch to the positive (+) 12-volt supply.
 - Fuse must be 1-amp.
2. Navigation rules require sidelights to be operated separately from anchor lights. Use either two switches or one switch with three positions for off/anchor/running.

Figure 1

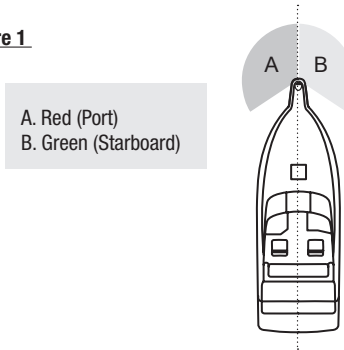

- A. Red (Port)
- B. Green (Starboard)

Figure 2

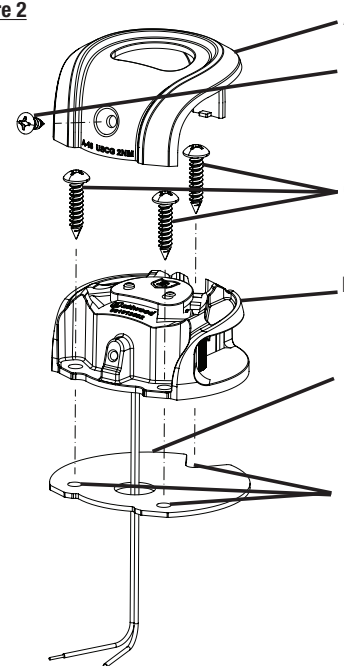

- A. Cover
- B. Assembly screw (provided)
- C. #8 pan head stainless steel screws (not provided)
- D. Housing
- E. Santoprene gasket
- F. Three pilot holes

Figure 3

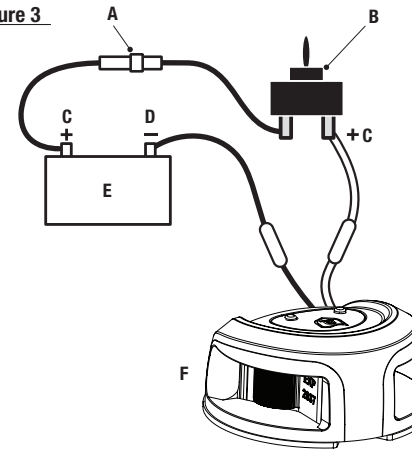

- A. 1-Amp Fuse
- B. Switch
- C. (pos)
- D. (neg)
- E. 12 V DC
- F. Bi-Color light