

INSTALLATION INSTRUCTIONS

GPS ELECTRIC MARINE SPEEDOMETER

2650-1596-00



Mounting

1. Mount a 3³/₈" speedometer in a 3³/₈" dia. hole and a 5" speedometer in a 4⁵/₈" dia. hole. Be careful not to cut the hole too large.
2. Cut a 3/8" dia. hole in the firewall for the speedometer wires. Place a rubber grommet in the hole and route the wires through the grommet to the engine compartment.
3. Connect the speedometer wires as shown in the wiring sections.
4. Secure the speedometer to the dashboard using the provided bracket and hardware.

3³/₈" Models

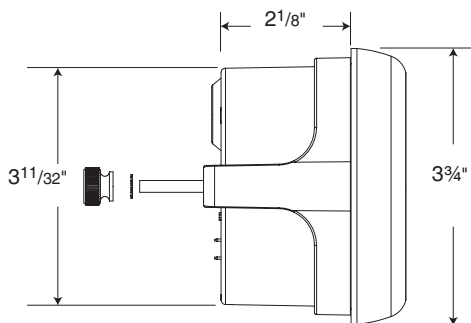

5" Models

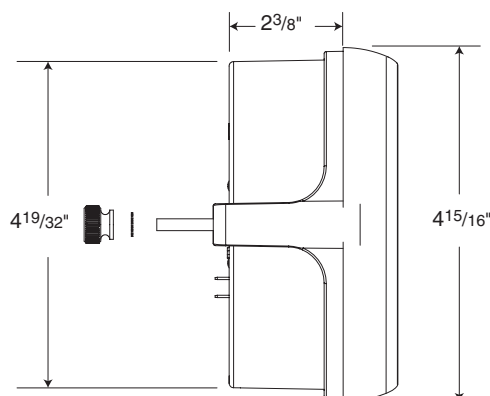

Wiring

Connect the GPS speedo as shown below. If the external GPS antenna (model #5283) is used it should be connected to the gold SMA connector on the back of the unit. External NEMA data can be connected to the speedo (requires purchase of wire harness model #5214). The baud rate of this data can be 4800, 9600, 19200, 38400, 115200. No parity, 1 stop bit. External data will take precedence over the antenna input.

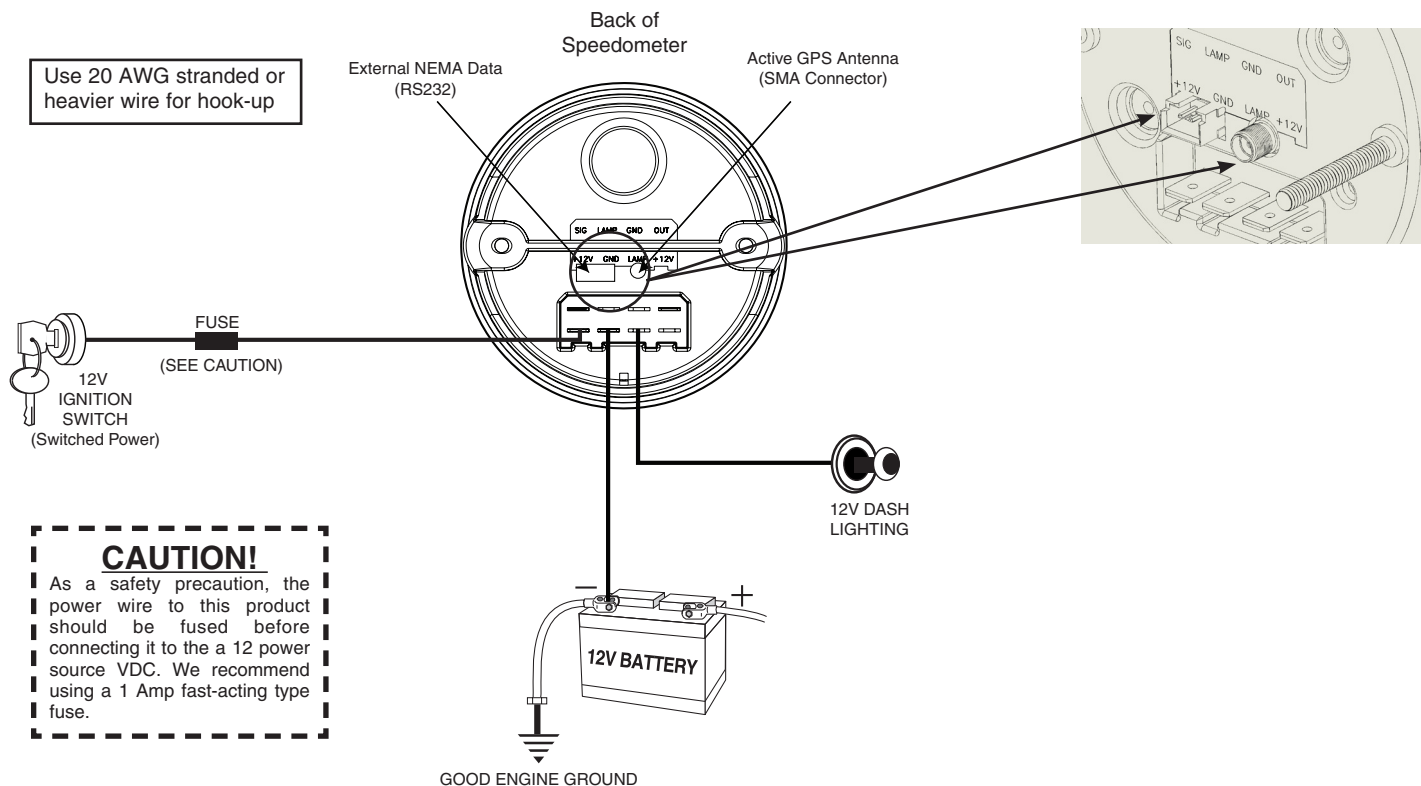

Testing

Once the speedometer is mounted and wired into the boat, the speedometer should be tested to verify that the electrical connections are working properly. First, watch the speedometer's pointer as the power is applied. The pointer should move up and then down to the 0 position on the dial. While the pointer is moving the LED display will show "AMP GPS". Once the pointer movement stops the LED display will show the firmware version number for a few seconds. If an external NEMA data source is connected, a menu item will be displayed followed by the data for this menu item. If only an external antenna is connected the time (this may or may not be the correct time) will be displayed with dashes between the digits, indicating no valid position. Once a valid position is determined the display will go to the last selected menu item. External data will take precedence over the antenna input.

Time Set Up

The time can only be set when there is a valid position, this will be indicated with colons between the time digits.

To set the current time, while in the time mode hold down the menu button and press the right button until the correct hour is displayed, release the menu button.

Operation

There are eight menu items to choose from: Time, Directional Heading, Peak Speed, Trip (distance), Odometer, Location, Hours and Display. Press the left button to cycle between the different menu items.

- Time - will display the current time.
 - Heading - will display your current heading when moving as a compass direction and heading in degrees.
 - Peak Speed – will display your peak speed. This value can be cleared by pressing and releasing the right button.
 - Trip – will display the number of miles traveled since it was reset. This value can be cleared by pressing and releasing the right button.
 - Odometer – Will display the miles traveled since installed. This value can not be reset.
 - Location – will display your current latitude and longitude.
 - Hours – will show engine hours since installed. This value can not be reset.
 - Display – will control the brightness of the display. There are 6 levels of brightness. After entering the display mode the current brightness level will be displayed. Pressing the right button will advance the current brightness level, returning to the lowest level after level 6. Pressing the menu button or not pressing any button for 4 seconds will return the display to the time mode.
-

Light Replacement (Models that have incandescent lighting only)

Remove the plastic cap on the back of the speedometer. Using needle nose pliers, rotate the twist-lock lamp socket counterclockwise to remove. Replace old bulb with GE 168 bulb.

NOTE: This Marine product is not waterproof, however has been built to be water resistant. Please try to avoid submerging this product in water.