

## Mounting

These gauges are panel mounted (2<sup>5</sup>/<sub>8</sub>" dia. hole for 2<sup>5</sup>/<sub>8</sub>" gauges) or (2<sup>1</sup>/<sub>16</sub>" dia. hole for 2<sup>1</sup>/<sub>16</sub>" gauges). Fasten with bracket supplied as shown. (Hookup wires are required.) To assure this instrument functions properly, please read instructions thoroughly before installing.

**CAUTION!** As a safety precaution, the +12 V terminal of this product should be fused before connecting it to the 12V ignition switch. We recommend using a 4 Amp, 3 AG fast-acting type cartridge fuse (Littlefuse® #312 004 or an equivalent).

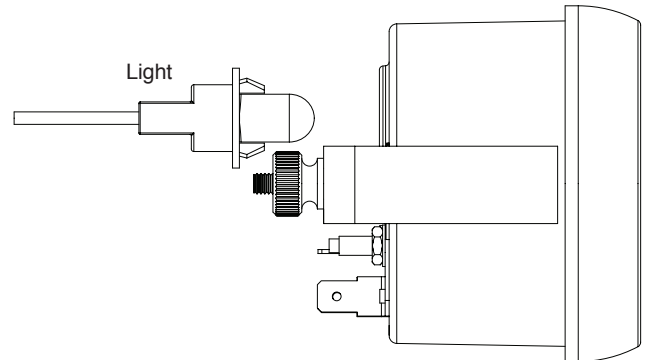

SIDE VIEW

## Fuel Level

**Disconnect negative battery cable when wiring and reconnect to check reading.**

1. Disconnect negative (-) battery cable.
2. Existing wires may be used, or route proper length of 18 gauge, 2 conductor wire from fuel tank to gauge. Connect one end to terminal post on fuel level sender and opposite end to sender (S) terminal on gauge.
3. Connect wire from gauge ground terminal [GND(-)] to fuel tank ground.
4. Connect wire from ignition switch to positive I (+) terminal on gauge.

**CAUTION: Be careful not to touch ignition wire to the sender (S) terminal on back of gauge or the sender will be damaged.**

5. Install the light in the socket on the rear of the gauge and connect one wire to the dash lighting circuit or other 12V power source. Connect the other wire to ground.
6. Reconnect negative (-) battery cable.

BACK VIEW

**Black Wire:**  
Connect to good ground or dimming circuits on some import vehicles

Replace light bulb with the same number bulb as the one removed.

**White Wire:** Connect to +12 Volt lighting

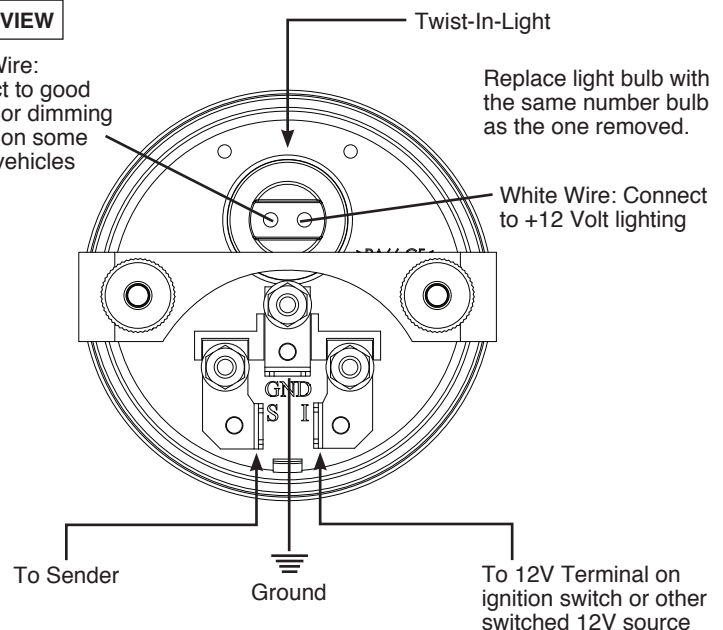

## Voltmeter

1. Disconnect negative (-) battery cable.
2. Using 18 gauge wire route one length through firewall using grommet. Attach one end to the [GND(-)] terminal on back of gauge, and the opposite end to a good engine ground.
3. Attach one length of wire to the positive I (+) terminal on back of gauge and opposite end to 12V terminal on ignition switch or other 12V power source.
4. Install the light in the socket on the rear of the gauge and connect one wire to the panel lighting circuit or other 12V power source. Connect the other wire to ground.
5. Reconnect negative (-) battery cable.

BACK VIEW

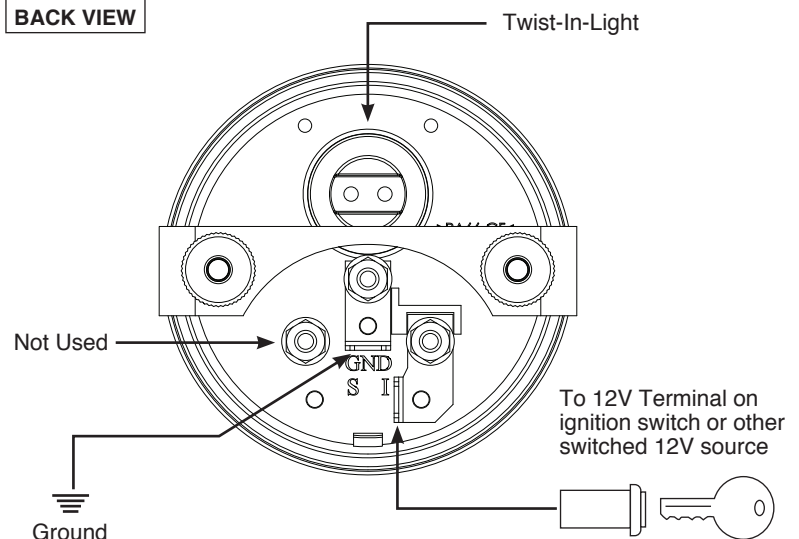

# Pressure Gauges

1. Disconnect negative (-) battery cable.
2. When installing fuel pressure sender, an adapter may be required for your specific application.
3. Install sender into pressure port of appropriate type. **If unit is to be installed on a high vibration application such as a full race engine or engine capable of high RPM, it is strongly recommended that the sender be remote mounted to the firewall or other structural member to insulate from vibration. Failure to remote-locate pressure senders on such an application could result in gauge failure and potential damage to vehicle and/or operator injury.** Braided stainless steel lines are sold separately by Auto Meter, and can be used to accomplish this. Sender should automatically be grounded when installed. If not, or if remote relocation of sender is required, a ground connection to sender "body" may need to be made.
4. Route 18-gauge twin conductor wire through firewall using grommet. Connect one end to terminal post on pressure sender, and opposite end to sender (S) terminal on back of gauge.  
**CAUTION: Be careful not to touch ignition wire to the sender (S) terminal on back of gauge or the sender may be damaged.**
5. Connect wire from ground terminal [GND (-)] on back of gauge to good engine ground near sender.
6. Connect wire from ignition switch to ignition I (+) terminal on back of gauge.
7. Install the light in the socket on the rear of the gauge and connect one wire to the panel lighting circuit or other 12V power source. Connect the other wire to ground.
8. Reconnect negative (-) battery cable.

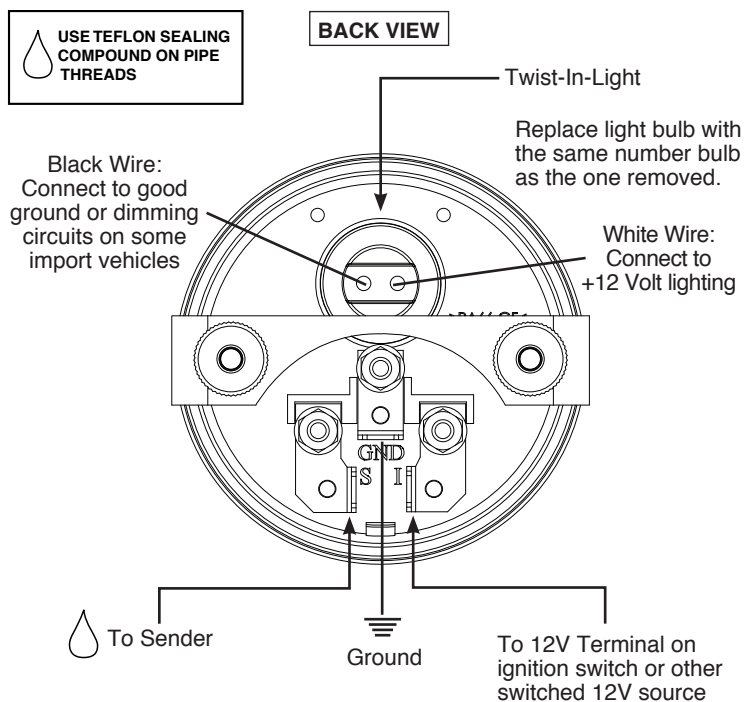

# Temperature Gauges

1. Disconnect negative (-) battery cable.
2. Install temperature sender.
  - A. Water Temp: Install temperature sender.
  - B. Oil Temp: Hole may have to be drilled and adaptor nut welded or brazed in pan. Be sure there is adequate internal clearance for nut and sender. Sender should automatically be grounded when installed. If not, proper ground connections should be made.
  - C. Cylinder Head Temp: Head must be drilled and tapped. Sender should be grounded automatically when installed. If not, proper ground connections should be made.
3. Route 18-gauge twin conductor wire through firewall using grommet. Connect one end to terminal post on temperature sender, and opposite end to sender (S) terminal on back of gauge.  
**CAUTION: Be careful not to touch ignition wire to the sender (S) terminal on back of gauge or the sender may be damaged.**
4. Connect wire from center terminal GND (-) on back of gauge to good engine ground near sender.
5. Connect wire from ignition switch to ignition I (+) terminal on back of gauge.
6. Install the light in the socket on the rear of the gauge and connect one wire to the panel lighting circuit or other 12V power source. Connect the other wire to ground.
7. Reconnect negative (-) battery cable.

