

Emergency Parallel Switch

720-MDO-EP

Operation and Installation Manual

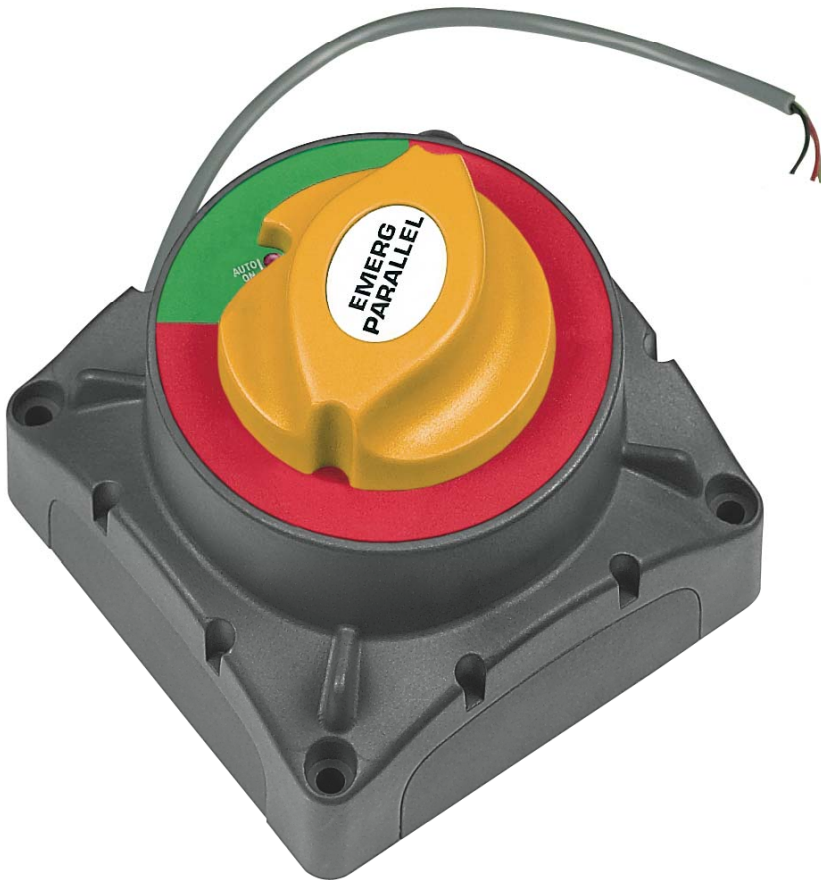

BEP

Introduction

The **Emergency Parallel** function can be operated through a remotely mounted momentary switch or button. The 720-MDO-EP will remain in parallel mode for 10 minutes. At any time depressing and holding the momentary switch or button for 5 seconds will disengage the 701-MDO-EP.

Manual Operation of the E.P can be overridden at anytime by depressing the control knob and turning clockwise towards the “Manual On” position or anti clockwise towards the “Manual Off” position. If the MD detects a manual override it will start rapidly flashing.

LED Indications

a. Auto Mode:

ON: EP is engaged

OFF: EP is disengaged

Rapid Flash: *On 0.1 Sec & Off 0.1 Sec;* The voltage is out side specification. i.e. Lower than 8V or higher than 30V

b. Manual Mode:

Rapid Flash: *On 0.1 Sec & Off 0.1 Sec;* 701-MD-EP is in manual override

Specifications

Continuous rating: 500 Amps DC
Intermittent rating: 700 Amps DC
Cranking rating: 2500 Amps DC
Maximum Voltage: 32 Volts DC
Operation: Manual On/Off
 Motorized On/Off

Mounting: Recessed or surface
Auto operating range 8 to 30 Volts DC
Ignition protected

Stud Size: 2 x 12mm(1/2")
Tin plated copper studs and nuts
Power draw:

Switch in off position: 7mA

Wiring

- Red** - LED Wire
- Green** - Control Wire
- Black** - Supply Negative
- Orange** - Supply Positive #1
- White** - Supply Positive #2

After installation please silicone the end of the outer sheath of the grey cable to preserve the IP65 rating. Ignore if this is not required.

Stud Input - High Current Contact

Stud Output - High Current Contact

Connect DC + to Supply Positive #1 (orange) or Supply Positive #2 (white) or both to power the 720-MDO-EP

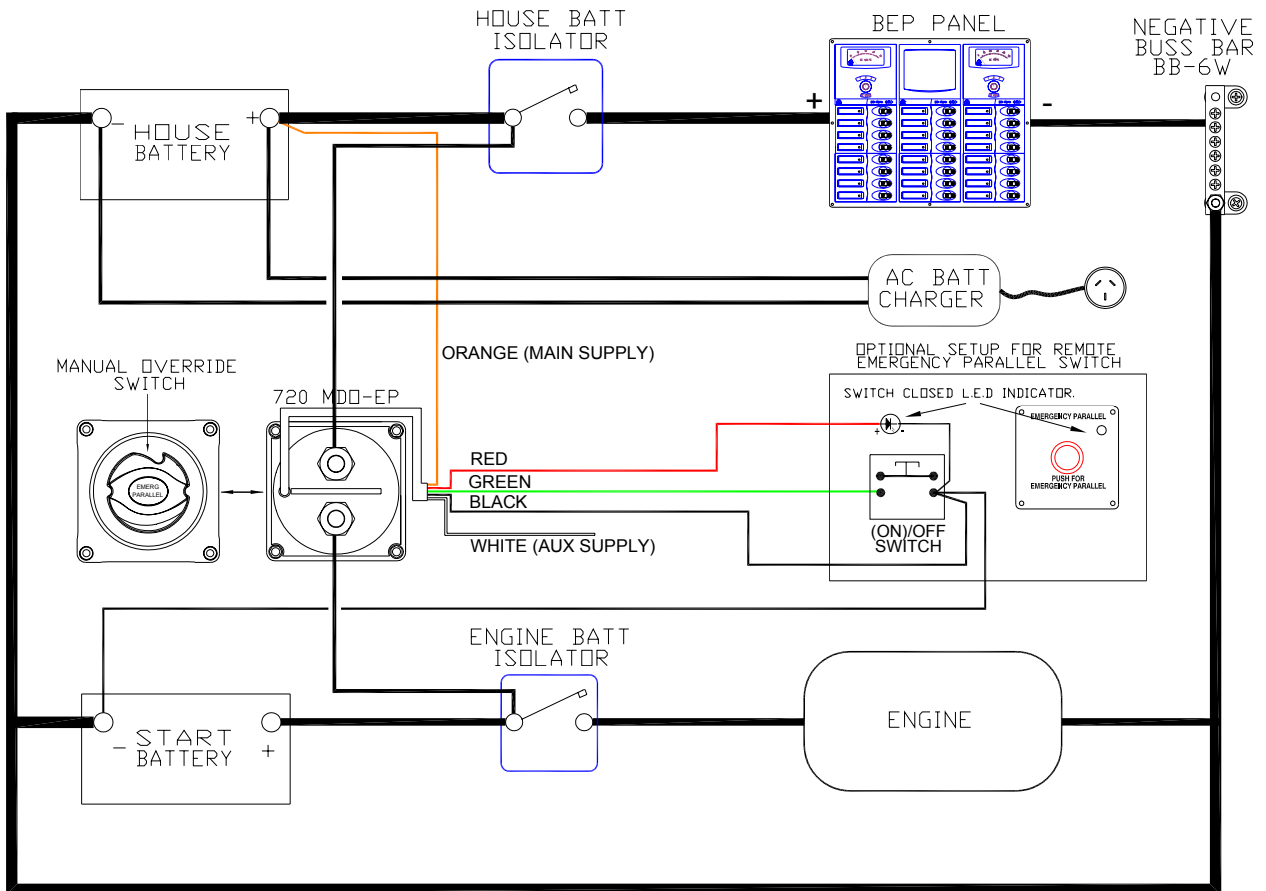

IT IS IMPERATIVE THAT THE NEGATIVE (BLACK) FOR THE MD/MDVS IS TAKEN FROM THE SAME BATTERY THAT IT IS ISOLATING. FAILURE TO DO THIS WILL CAUSE THE UNIT TO WORK ERRATICALLY. ONLY ONE NEGATIVE MUST BE SUPPLIED TO EACH UNIT FOR CORRECT OPERATION.

Dimensions

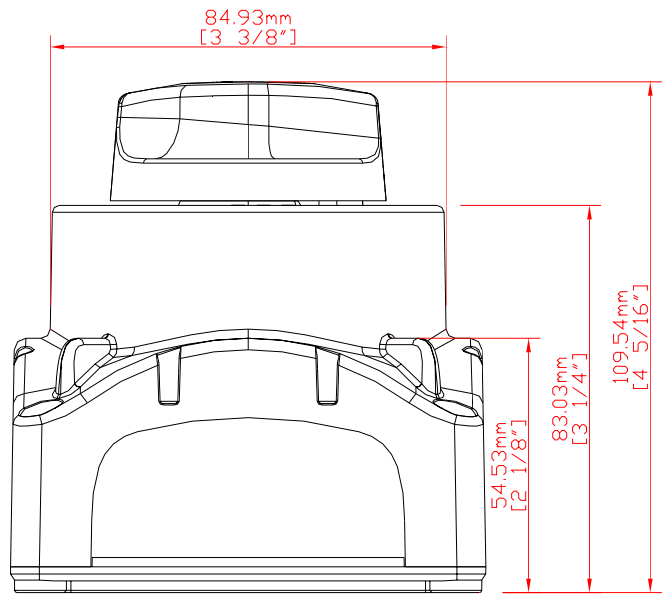
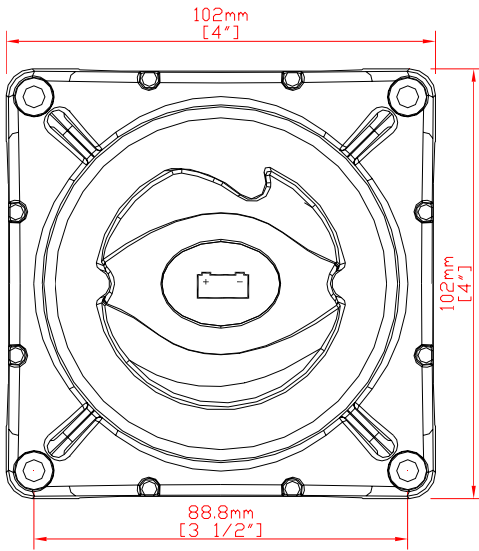

Cut Out Measurements

