

**Motorised Battery Switch**  
**Model: 720-MDO (Version 8)**  
**OPERATION AND INSTALLATION INSTRUCTIONS**

**BEP**  
LEADING ELECTRICAL DESIGN



**INTRODUCTION:**

The 720-MDO is a high current, remotely activated battery switch. This allows convenient operation with the remote switch within easy reach of the user, and the battery switch positioned where cable runs are minimized. Reduced cable runs allow smaller section cable to be used, resulting in significant reductions in cable cost, plus weight savings.

As well as remote, motorized operation, the 720-MDO can be manually over-ridden. From the "Manual Off" position, the switch knob can also be removed, providing security, particularly during servicing.

Designed and constructed for longevity in the marine environment with tinned copper conductors, stainless steel nuts and high temperature, fibre reinforced plastics. The units are ignition protected, provide On/Off switching operation, and may be recessed or surface mounted.

The Version 8 printed circuit boards include the latest developments in digital circuitry, and optical position sensing. These result in significant improvements to voltage measurement circuits, switch operation, and provide low power consumption.

**BEP**

**MASTERVOLT**

**MARINCO**

# Motorised Battery Switch

## Model: 720-MDO (Version 8)

### OPERATION AND INSTALLATION INSTRUCTIONS

The 720-MDO Version 8 offers a number of advanced installation options, whereby the motor/circuit board can be fed from an independent 12V or 24V supply, so the switch contacts are fully isolated and can:

- Still be operated in case the switched battery is flat
- Control higher voltage circuits e.g. 32 or 48 volt circuits
- Control negative cables in circuits (e.g. full isolation in metal hulled craft)
- Ensure engine electronics are fully isolated from all loads
- Note Version 8 720-MDO's can be identified by the 7 core connection cable with 3 cores terminated in the Wago plug, and 4 cores crimp-terminated

Typical installation is with a key-operated switch at the helm station and with the motorised battery switch installed as close as practical to the battery bank. Although any switch may be used BEP offer the specially developed 80-724-0006-00 key switch (pictured at right).



Another option is to use BEP's Wireless Remote Control. This is similar to a car remote, and provides access from up to 80m. Working through a 4 channel relay, the wireless remote (part number 80-911-0045-00) can be configured to control items such as motorised battery switches, entry lights, hatch lifters etc in order to offer safe, easy entry to your vessel (pictured at right).



## SPECIFICATIONS:

- **Continuous rating:** 500 Amps DC - minimum 2x95mm<sup>2</sup> (2x 3/0) cables
- **Intermittent rating:** 700 Amps DC - minimum 2x95mm<sup>2</sup> (2x 3/0) cables
- **Cranking rating:** 2500 Amps DC - minimum 2x95mm<sup>2</sup> (2x 3/0) cables
- **Maximum Voltage:** 32 Volts DC (for motor/PCB supply)  
50 Volts DC (switch contacts – note motor/PCB supply requires 12/24 volts)
- **Auto operating range:** 8 to 32 Volts DC
- **Operation:** Manual On/Off, Auto On/Off
- **Mounting:** Recessed or surface
- **Ignition protected** Meets UL 1107 standards
- **IP Rating** IP65
- **Stud Size:** 2 x 12mm (1/2") – See Installation section for torques
- **Materials:** Tinned copper conductors/studs, stainless steel nuts, high temperature fibre reinforced plastics
- **Power draw:** Switch in off positions: <=5mA@12V or 24V  
Switch in "Auto On" 9mA @12V, 13.5mA @24V

### Wires For Standard Connection:

- Red** • LED Wire
- Green** • Control Wire From Remote Switch
- Black** • Supply Negative
- Input Stud** • High Current Connection From Battery
- Output Stud** • High Current Connection To Loads

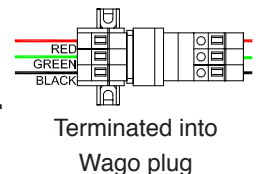

### Wires For Advanced/Optional Connections:

- Brown** • Power Supply From Input Stud
  - Orange** • Motor/PCB Supply Positive #1
- Brown takes power from the Input stud, and Orange takes this to the circuit board/motor to control the battery switch.
- Blue** • Power Supply From Output Stud
  - White** • Motor/PCB Supply Positive #2
- Blue takes power from the Output stud. White is a secondary connection to provide power to circuit board/motor. Both isolated as standard.

# Motorised Battery Switch

Model: 720-MDO (Version 8)

## OPERATION AND INSTALLATION INSTRUCTIONS

### DIMENSIONS:

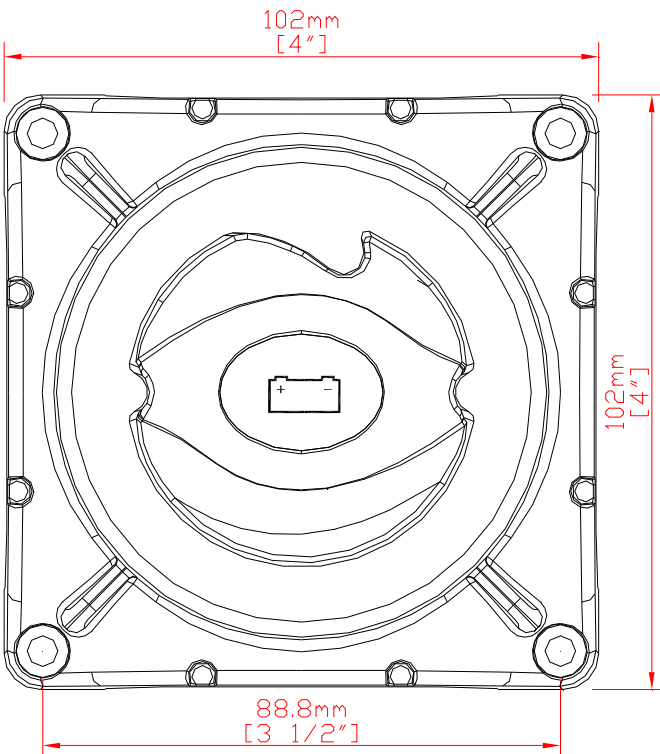
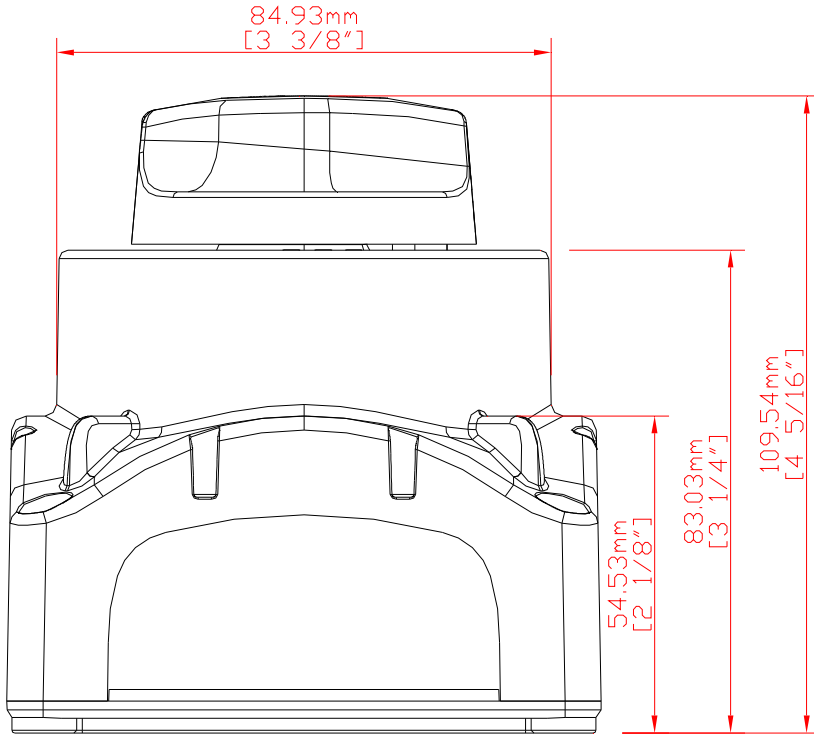

### LABEL OPTIONS:

- Label set 713

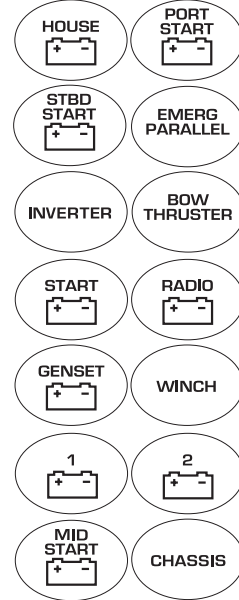

# Motorised Battery Switch

Model: 720-MDO (Version 8)

## OPERATION AND INSTALLATION INSTRUCTIONS

### GENERAL OPERATION:

**Note that the knob must be firmly depressed prior to manual rotation, in order to disengage the motor drive. Failure to do this could damage the motor drive.**

The Motorised Battery Switch, (720-MDO) has two modes of operation, Auto and Manual. There is an LED located on both the battery switch and the optional remote key switch, indicating battery switch status.

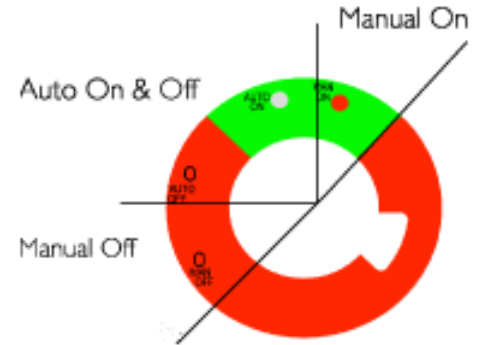

### AUTO OPERATION:

When the remote switch is turned on, the 720-MDO moves from a state of “Auto Off” to “Auto On”, and the “Auto On” LED becomes illuminated.

Auto operation of the Battery Switch is not possible whilst in manual mode. Knob must be returned to “Auto Off” or “Auto On” before normal auto operation can continue.

#### Auto Mode LED Indications:

**LED OFF:** Battery switch is off

**LED ON:** Battery switch is on

### MANUAL OPERATION:

The automatic operation of the 720-MDO battery switch can be overridden at anytime by depressing the control knob and turning clockwise towards the “Man On” position or counter clockwise towards the “Man Off” position.

During the time that the Battery switch is in “Man On” mode, the “Man On” LED is illuminated.

**Removing the switch knob:** The knob is removable for security or maintenance reasons.

Place switch in “Manual Off” position, then press and rotate the knob anticlockwise to remove. Once knob is removed, remote activation of the battery switch is not possible.

### INSTALLATION:

**Note:** For standard installation (PCB/motor power supply using factory default configuration), **Battery must be connected to the Input Stud**, otherwise switch will not operate in Auto mode.

Battery cables must be correctly selected for the maximum loads expected.

Cables must be a minimum of 1x 95mm<sup>2</sup> (3/0) to achieve 350 amps continuous.

Cables must be a minimum of 2x 95mm<sup>2</sup> (2x 3/0) to achieve 500 amps continuous.

Ensure nuts on studs are correctly tightened. Recommended torque is 18 Nm (13.3 lbf). Maximum torque 25 Nm (18.5 lbf).

Any latching on/off remote switch can be used to activate the 720-MDO.

**STANDARD INSTALLATION DRAWING:**  
(Provided only as a guide for installation, not as a complete system design)

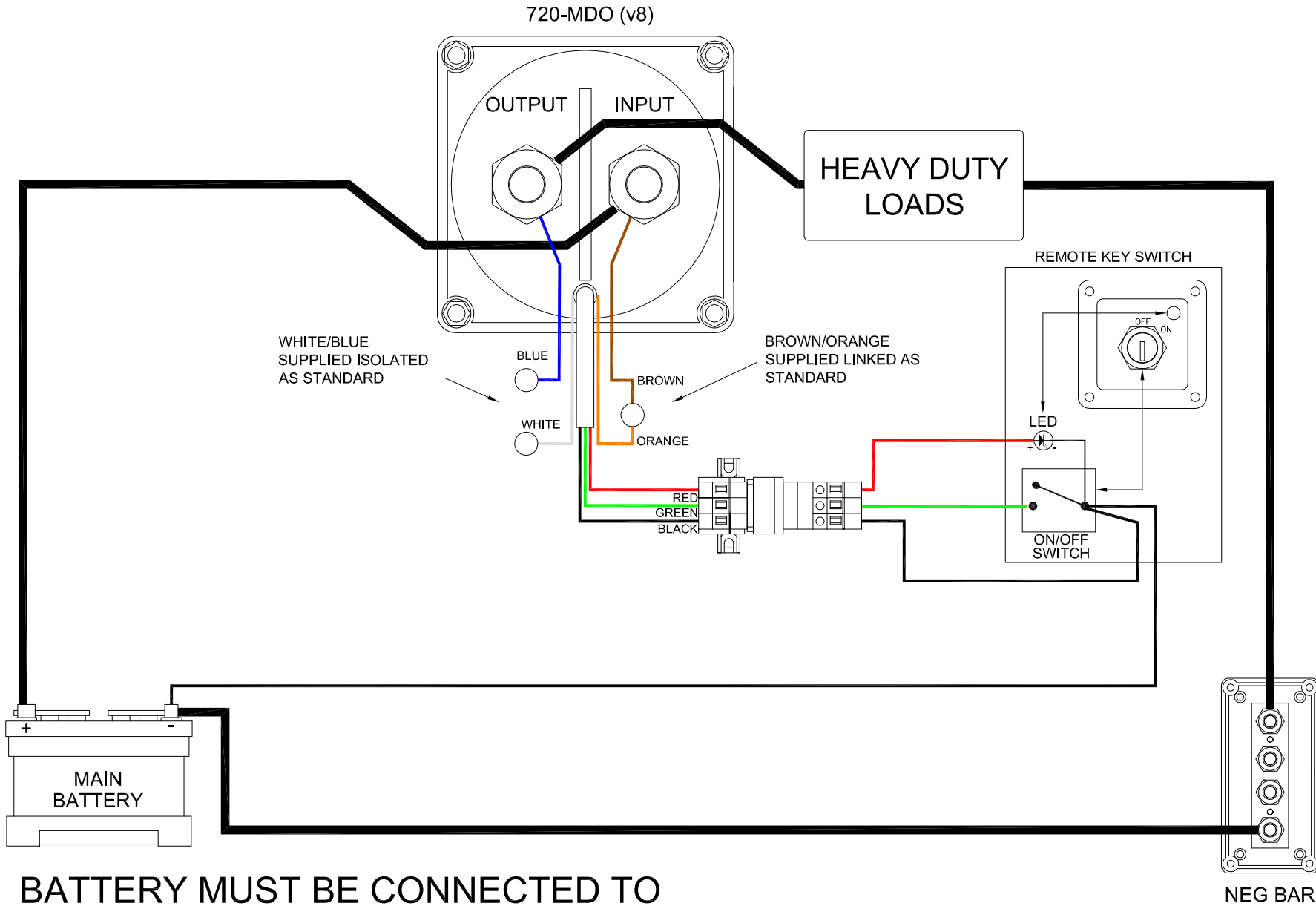

**BATTERY MUST BE CONNECTED TO INPUT STUD WITH STANDARD INSTALLATION.**

## OPTIONAL INSTALLATION: Switch contacts isolated from circuit board/motor supply

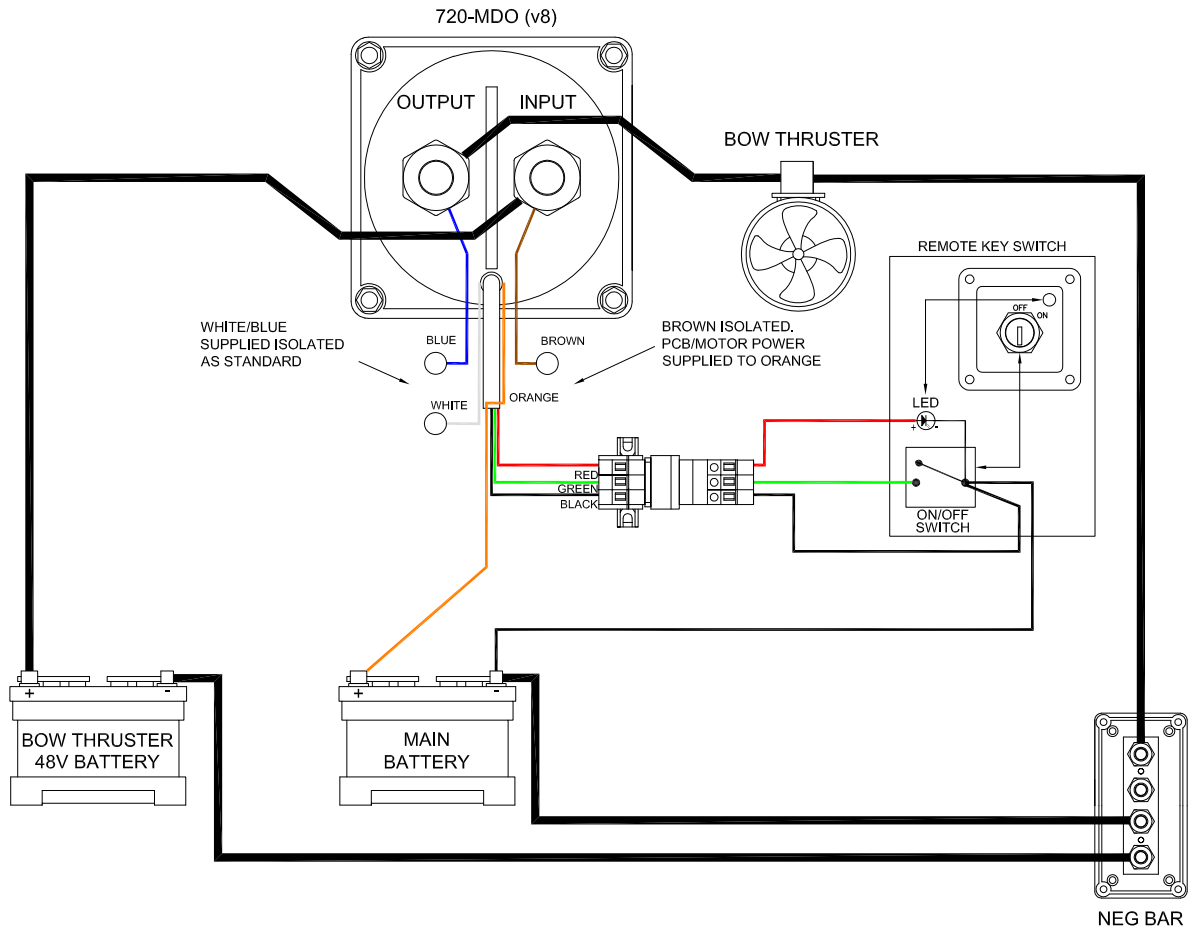

## OPTIONAL INSTALLATION: As a Parallel Switch

OPTIONAL INSTALLATION: AS A PARALLEL SWITCH.

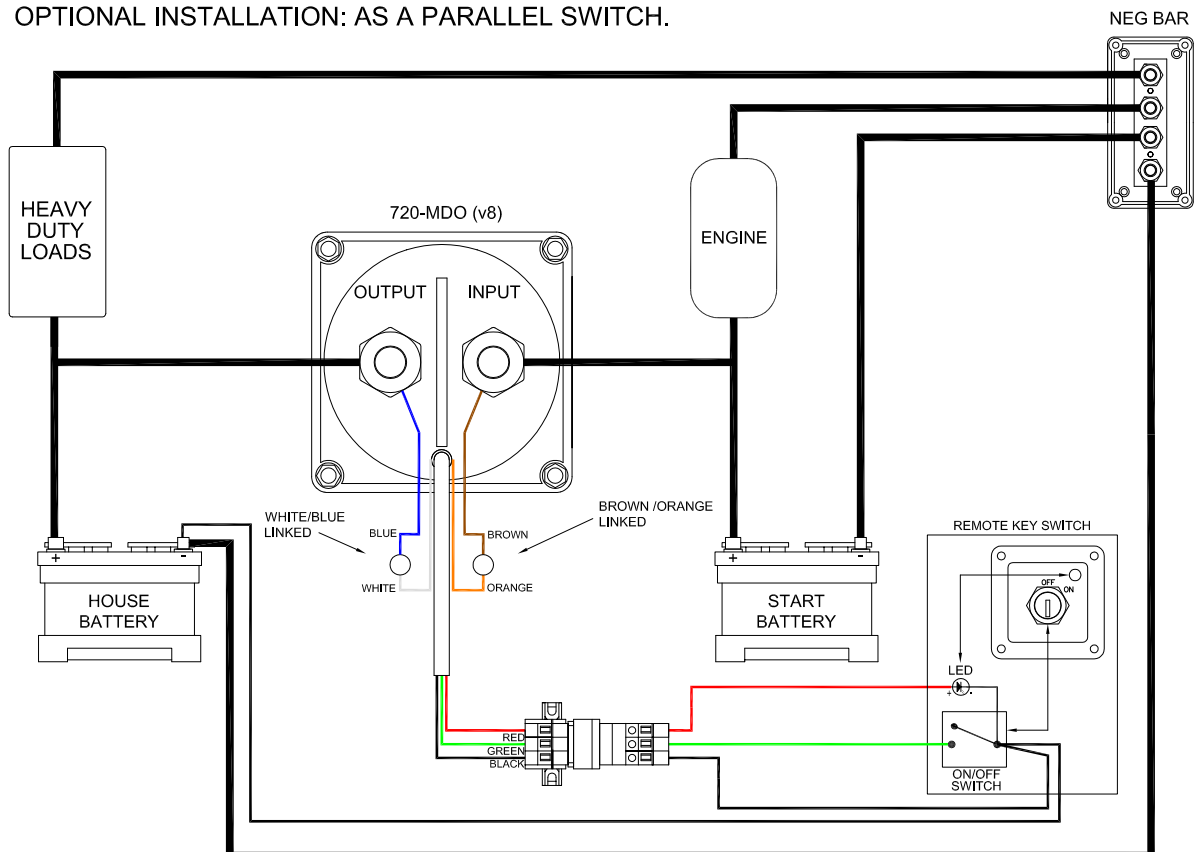

# Motorised Battery Switch

Model: 720-MDO (Version 8)

## OPERATION AND INSTALLATION INSTRUCTIONS

### CUT OUT MEASUREMENTS (NOT TO SCALE)

