

## HD-Series Heavy Duty Selector Battery Switch with AFD\*

PN 3003

### Features

- Selects battery bank 1 or battery bank 2, or 1+2 for charging or emergency starting
- Up to 500 Amperes continuous rating for large diesel engines, high power output, and low heat generation
- Alternator Field Disconnect (AFD) protects the diodes in the alternator in the event of the switch being switched to the OFF position while the engine is running

#### Tin-plated copper studs:

- M12-1.75 (1/2") provide maximum conductivity and corrosion resistance
- One-piece to reduce risk of overheating
- 7/8" (22.22mm) length to accept multiple cable terminals

#### Case design:

- Allows surface mounting or rear panel mounting
- Accepts 4/0 AWG (120 mm<sup>2</sup>) battery cables

### Specifications

Cranking Rating: 30 sec.	1,600A
Intermittent Rating: 5 min.	700A
Continuous Rating	500A
Voltage Max. Operating	32V DC
Terminal Stud, Tin-Plated Copper	M12-1.75 (1/2")
Torque	220 in-lb (24.86 N·m)
Cable Size to Meet Ratings**	4/0 AWG (120 mm <sup>2</sup> )
Maximum Voltage Rating	32 Volts DC
Ignition Protected	
CE marked	

### Agency Specifications

- Meets all American Boat and Yacht Council (ABYC) requirements for battery switches
- UL Listed - UL 1107 for electric power switches
- Meets UL 1500 and SAE J1171 external ignition protection requirements

## Caution

- Disconnect positive battery terminal before installing.
- Consult marine electrical professional for proper wiring application.

## Installation

- Mount in an easily accessible location close to the batteries.
- Attach one 4/0 cable to each battery terminal and two 4/0 cables to the common terminal to meet rating.
- Refer to the latest edition of NFPA 302 and/or ABYC E11 Standard for installation information.
- Battery cable terminals must be attached under nut. Torque 220 in-lb (24.86 N·m).
- AFD: Cut the field wire from the alternator to the voltage regulator; connect one end to F1, and the other end to F2.

## Operation

- Turn all appliances off before turning the battery switch to OFF.
- Do not switch to OFF while engine is running.

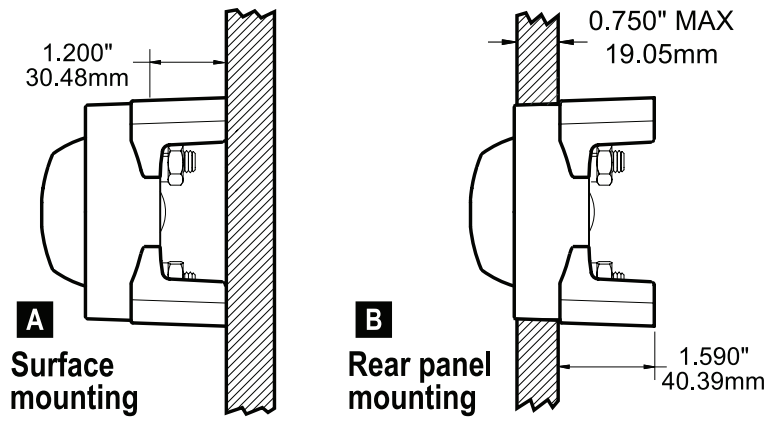

Switch Mounting Options

