

AC Rotary Switch

3 Positions + OFF, 2 Pole

PN 9010

Features

- Switches 3 - 120V AC Sources
- Compact solution when circuit protection is provided elsewhere
- Allows connecting one of three different AC sources to one circuit
- Heavy duty industrial rated switches
- Intuitive function - One handed operation
- UL listed switches

Specifications

Amperage Rating:	32 Amperes Maximum	
Voltage Rating:	600 Volts AC Maximum	
Maximum Wire Size:	10 AWG	
Minimum Wire Size:	14 AWG	
Terminal Recommended Torque:	12 lb-in.	
	Inches	Millimeters
Overall Dimensions:	1.890 x 1.890	48.00 x 48.00
Mounting Depth:	2.41	61.2
Maximum Panel Thickness:	0.157	4.00

⚠ WARNING ⚠

- ✔ These instructions are intended to provide assistance with the installation of this product, and are not a substitute for a more comprehensive understanding of electrical systems. We strongly recommend that a competent electrical professional perform the installation of this product.
- ✔ If either the switch front or back is to be exposed to water it must be protected with a waterproof shield.
- ✔ The switch must not be installed in explosive environments such as gasoline engine rooms or battery compartments as the switches are not ignition proof.
- ✔ The vessel's shore power cord must be disconnected from shoreside power before installing this electrical switch.
- ✔ If an inverter is installed on the vessel its power leads must be disconnected at the battery before the panel installation. Be aware that many inverters have a "sleep mode" in which their voltage potential may not be detectable with measuring equipment.
- ✔ If an AC Generator is installed aboard it must be stopped and rendered inoperable before the switch is installed.
- ✔ Verify that no other AC or DC source is connected to the vessel's wiring before the switch is installed.

Installation

1. Disconnect all AC and DC power

Disconnect all AC power originating on or off the vessel. This includes inverters, generators, shore power attachments and any other device capable of supplying AC power to the ship's circuits.

Disconnect the main positive DC cable from all batteries to eliminate the possibility of a short circuit and to disable the inverter while installing the switch.

2. Select mounting location and cut opening

Select a mounting location which is protected from water on the front and back of the switch and is not in an area where flammable vapors from propane, gasoline or lead acid batteries accumulate. AC rotary switches are not ignition protected and may ignite such vapors.

Using the template provided, drill the mounting surface where the switch is to be mounted. The mounting surface maximum thickness is 0.157" (4.00mm). Do not yet fasten the switch to the mounting surface.

3. Install source 1, source 2, source 3, and output wires

Install the feed wires from AC Shore Power and AC Generator. Install the output wires. Refer to the wire sizing chart to select the proper wire size. Connect the black AC hot, white AC neutral and green AC safety ground as shown in the illustration. To avoid excess wire temperatures when cooling may be limited, we recommend using at least 12 gauge wire for 30A.

Do not confuse the neutral current carrying wires (sometimes called ground) with the green normally non-current carrying wires (sometimes called grounding). These two wires must be connected only at the source of power, nowhere else.

A double pole circuit breaker must be installed within 10 feet of the shore power inlet, ahead of this switch. The measurement is made along the conductors.

The switch provides switching, but does not provide circuit protection. It is not a substitute for a main circuit breaker.

Wire sizing chart

Use the wire sizing chart below to determine the proper branch and feed circuit wire sizes.

Allowable Amperage of Conductors

Wire Size (AWG)	Outside Engine Spaces	Inside Engine Spaces
16	25.0	21.3
14	35.0	29.8
12	45.0	38.3
10	60.0	51.0
8	80.0	68.0
6	120.0	102.0
4	160.0	136.0
2	210.0	178.5

Note: This chart assumes wire with 105°C insulation rating and no more than 2 conductors are bundled. Not suitable for sizing flexible shore power cords.

4. Testing

It is very important that wiring be connected according to the diagram. The hot lines and neutral from each source must be identified and grouped together so that the switch selects all of the lines from the same source and does not accidentally select lines or neutrals from more than one source. Verify the connections and see that each connection is securely tightened, including the terminals for the jumpers installed on the switch where no wires are attached.

If you are using this switch for other purposes, such as voltage tap selection on a transformer, please review your installation diagram and devise a suitable test plan to verify your connections.

Installation (continued)

It is possible to verify most connections using an ohmmeter before power is applied. These procedures take a little time, but are recommended, especially if some elements of a previous installation might not have been clearly or correctly labeled or follow the expected color codes.

There are many possible sources that may be selected using this switch, and they may be arranged in any order. The following test instructions are generally suitable for shore and generator installations. The third source may be another shore power inlet or an inverter or other specialized source.

✓ Test Shore Connection to Switch

Disconnect the shore power cord from the shore power source and bring the shore plug aboard to a point close to the switch panel. Connect the other end of the shore cord to the boat's power inlet. Turn ON the shore power circuit breaker between the inlet and the selector switch. Set the selector switch to OFF.

- Use an ohmmeter to check for continuity from the shore ground plug to the green wire at the electrical panel.
- Check for continuity from the power cord plug neutral pin to the neutral wire (white typically in US, light blue typically in Europe) at the selector switch.
- Check for continuity between the line pin of the shore plug and the line wire (typically black in US, brown in Europe) at the selector switch.
- Check that there is a high resistance between (>1000 Ohms) the neutral conductor and the grounding conductor.
- Verify that there is a high resistance between (>1000 Ohms) between the shore cord plug neutral pin and line pin. There may be indicator lamps in the circuit, but no more than that with the selector switch in the off position.

✓ Verify Switch Selects Shore Input

With the shore cord still disconnected from the shore and available onboard, and the generator set not operating, set the load circuit breakers to off, so there is no load at the output side of the selector switch.

- Verify that there is a high resistance between the line and neutral of the load side terminals of the selector switch. There may be indicator lamps still attached, so it may not read open circuit.
- Set the selector switch to SHORE. The ohmmeter should still indicate a high resistance.
- Short the line pin to the neutral pin of the shore cord and verify that the line and neutral at the load side of the selector show a low resistance when these are shorted and a high resistance when they are not.

✓ Verify the Generator Wiring

Turn the generator circuit breaker to OFF and set the selector switch to the generator position. All load circuit breakers should still be off. Leave the shore input circuit breaker in the on position.

- Verify that there is a high resistance (>1000 Ohms) from the line to neutral.
- Verify that there is a low resistance from the neutral to ground at the load connections.
- With the generator still not running, close the generator circuit breaker at the generator. Verify that there is a now a low resistance from line to neutral where the generator windings are now connected across the circuit.
- Verify that there is still a high resistance from neutral to ground and neutral to line at the shore power plug.

✓ Test the third source in a similar manner.

✓ Set the Selector switch to **OFF**, turn the shore power breaker to **OFF**, and leave the load panel circuit breakers in the **OFF** position. Complete the mounting of the switch.

✓ **Set your multimeter to volts.**

✓ Test Shore Power

Connect the shore power cable to the shore power source. Turn on the shore source to make power available to the boat.

- Turn the selector switch to **SHORE**. No Reverse Polarity lights should be lit, and power available should be indicated. If any red Reverse Polarity lights are on, turn off the shore power circuit breaker and disconnect the shore cord at the shore source. Either the hot and neutral or hot and ground wires have been reversed. Starting at the distribution panel, trace the connections as far back as necessary to locate the error.
- If there are no indications of reverse polarity, check to see that power is available. If the electrical distribution panel has a meter, verify that shore power is available and at the proper voltage. If there is no meter, turn on the load circuit breaker for an AC circuit powering a convenience outlet and use a voltmeter to verify that power is available from line to neutral at the plug. Verify that there is no voltage between ground and neutral.

✓ Test Generator System

Turn the circuit breaker at the shore source to **OFF**. Set the selector switch to **OFF**. The shore power available lights should all be off. Start the generator and turn the generator breaker to **ON**.

- If there are power available lights for the generator output, they should light.
- There should be no power available indication at the shore power circuit breaker.
- Set the selector switch to **GENERATOR**. Power should be available at the power distribution panel. If the electrical distribution panel has a meter, verify that power is available and at the proper voltage.
- There should be no power available lights indicating at the shore circuit breaker.

✓ Test the third source in a similar manner.

The Purpose of the AC Source Selector Switch

Alternating Current (AC) power changes polarity 60 times per second in the US, Canada and Latin America and 50 times per second in Europe. This is the frequency of the power and is referred to as Hertz (or the now outdated term "cycle"). Because of this alternating nature of AC power, two live sources of AC power, such as shore power and inverter power, or shore power and a generator, cannot be electrically connected. The AC Source Selector switch is designed to connect two sources of AC power to a common circuit while preventing both sources from being connected to the circuit simultaneously.

Useful Reference Books

- Calder, Nigel (2005). *Boatowner's Mechanical and Electrical Manual* (3d ed). Camden, ME: International Marine / McGraw-Hill.
- Wing, Charlie (2006). *Boatowner's Illustrated Electrical Handbook* (2d ed). Camden, ME: International Marine / McGraw-Hill.

Other Innovative Products from Blue Sea Systems

- 360 Panel System
- Battery management solutions
- AC and DC circuit protection devices
- WeatherDeck™ waterproof panels
- BusBars, fuses, and fuse blocks
- Analog and digital meters

Installation (continued)

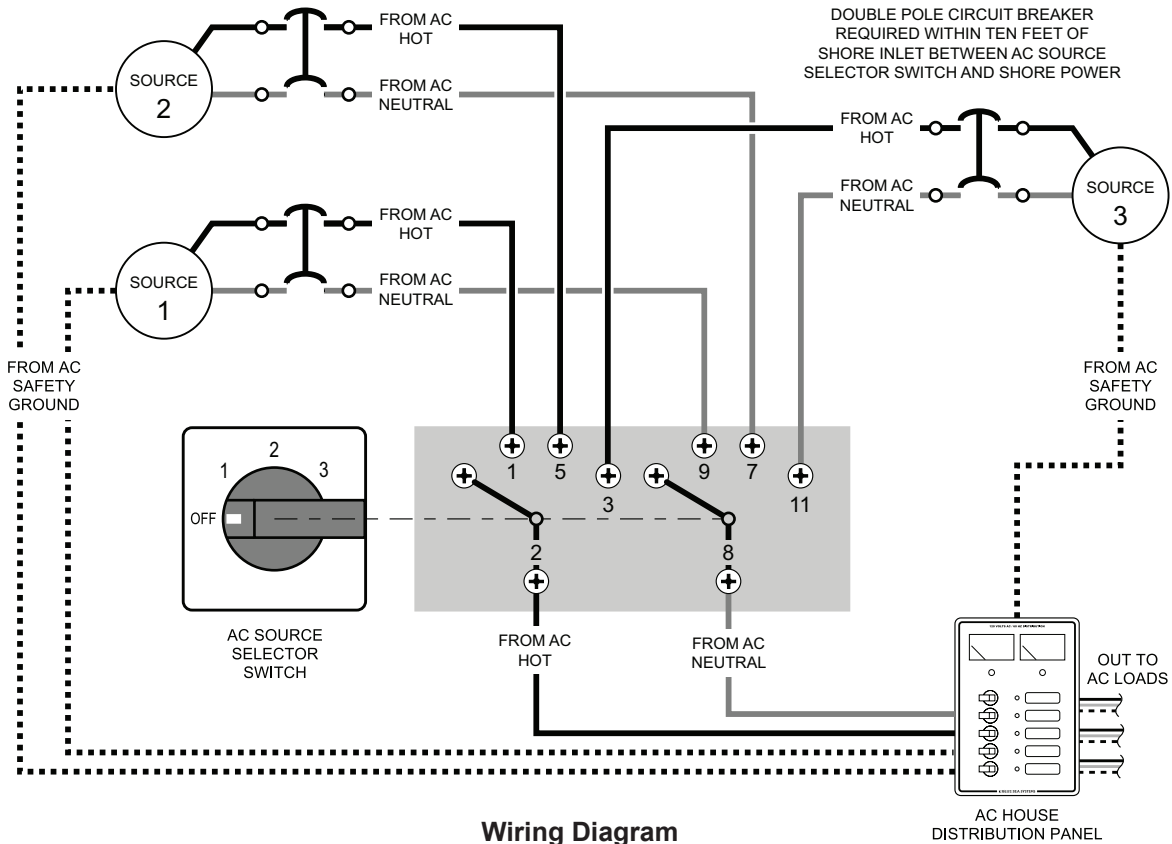

Wiring Diagram
AC Rotary Selector Switch
PN 9010

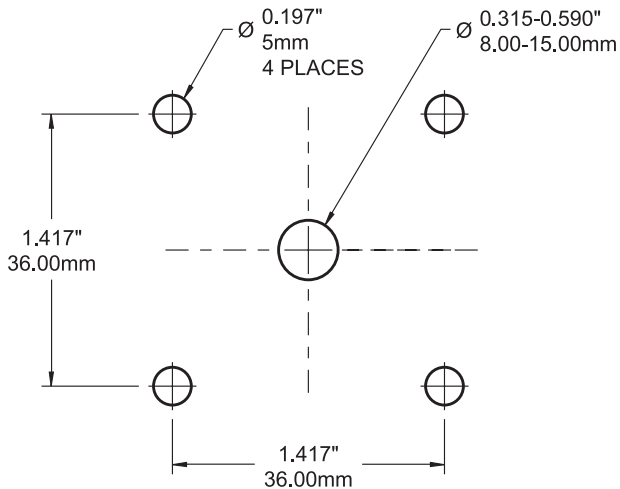

**Panel Mounting
Hole Pattern**
PN 9010

Part Number	L	
	Inches	Millimeters
9009	0.35	9
9010	0.35	9
9011	0.60	15
9019	0.60	15
9077	0.60	15
9093	0.60	15

Wire Strip Length

