



Installation and Troubleshooting Guide

All rights reserved. Reproduction or use of content, in any manner, without express written permission by CDI Electronics, Inc., is prohibited.



CDI P/N: 176-3095

This stator replaces P/N's 658095, 663095, 663095-1, 663095-2, 663095-3, 663095-4, 695095, 694095, 694095-1, 694095-2, 721095, 722095, 300-888793, 300-F658095, 300-F663095, 300-F694095-2, 300-F695095 and 300-F722095 (2, 3, 4 and 5 cylinder with crow's foot connectors).

Warning! This product is designed for installation by a professional marine mechanic. CDI cannot be held liable for injury or damage resulting from improper installation, abuse, neglect or misuse of this product.

NOTICE!! This stator has been redesigned to enhance durability and reduce inventory stock levels. It replaces the original dual winding with a single winding with larger wire. This design allows the stator to be used for the 2, 3, 4 and 5 cylinder applications.

Installation

2 Cylinder Using a Single Ignition Pack and Two Coils

Replace the original stator with the new one, matching wire colors (Some of these systems use brown/blue for blue and brown/yellow for yellow). Connect all of the Yellow (Brown/Yellow) wires to the Yellow wire from the pack and all of the Blue (Brown/Blue) wires to the Blue wire from the pack.

2 Cylinder Using Combination Pack and Coil (2 per engine)

Replace the original stator with the new one. Connect the Brown/Blue wires to the #1 coil pack and the Brown/Yellow wires to the #2 coil pack.

3 Cylinder

Replace the original stator with the new one. Connect both Brown/Blue wires on the new stator to the pack firing #1 and #2. (Like on a four cylinder engine).

4 Cylinder

Replace the original stator with the new one, matching wire colors (Some of these systems use brown/blue or brown/black/blue for blue and brown/yellow or brown/black/yellow for yellow).

5 Cylinder

Replace the original stator with the new one, matching wire colors (Some of these systems use brown/blue or brown/black/blue for blue and brown/yellow or brown/black/yellow for yellow). Install the supplied jumper wire from the #2 Brown/Yellow wire to the Brown/Yellow wire for the #3 cylinder. If the original stator had a 2 pin plug on the battery charge wires, remove it from the old stator. Cut the ring terminals from the new stator and use butt splice connectors to connect the plug to the new stator's battery charge wires.

TROUBLESHOOTING

NO SPARK ON ANY CYLINDER:

1. Disconnect the Kill (Stop) wires, typically White or Black/Yellow. If spark returns, there is a problem in the Kill circuit, possibly the ignition switch.
2. Disconnect the Green wires to the rectifier. If spark returns, replace the rectifier.
3. Check both Stator leads and check the resistance and DVA of the Stator as follows:

WIRE	Read To	CDI Ohms	DVA Connected	DVA Disconnected
Brown/Blue	Blue or Brown/Blue	250-350	180V or more	225V or more
Brown/Yellow	Brown/Yellow	250-350	180V or more	225V or more
Brown/Blue	Engine Ground	Open		2 V or less
Brown/Yellow	Engine Ground	Open		2 V or less

4. Check the flywheel outer magnet and make sure it has not broken loose from the flywheel.

NO SPARK ON ONE CYLINDER:

1. Swap the coil connections of the cylinder not firing with one that is firing. If the problem moves, replace the coil.
2. Check the resistance of the trigger lead sets. Each set should read approximately 50 ohms and give a minimum on 0.5V at cranking.
3. Disconnect the stator leads to the packs, one at a time. If the cylinder not firing starts firing, replace the power pack you just disconnected.
4. Swap the trigger wires for the cylinder not firing with one that is firing. If the problem moves, replace the trigger.
5. Gently pull on the Brown/Blue and Brown/Yellow wires close to the connector. If the insulation stretches, the wire is broken inside the insulation and a new terminal needs to be put on.
6. Swap the Brown/Blue and Brown/Yellow wires and see if the problem moves to the other cylinder. If it does, the stator is defective. If not the power pack is likely bad.

NO SPARK ON TWO CYLINDERS:

1. If two cylinders from the same CD unit will not fire, swap the stator leads. If the problem moves, check the stators wires by pulling on the wires to the connector.
2. Swap the trigger wires for the cylinders not firing with the cylinder with fire. If the problem moves, replace the trigger. If no change, replace the power pack(s).



Installation and Troubleshooting Guide

All rights reserved. Reproduction or use of content, in any manner, without express written permission by CDI Electronics, Inc., is prohibited.



CONNECTIONS

2 Cylinder Using Combination Pack and Coil (2 per engine)

Pack #1 (Firing #1 cylinder)

Trigger: Orange Pack: Orange
 Green Green
 Stator: Brown/Yellow Stripe (2 wires) Pack: Blue

Pack #2 (Firing #2 cylinder)

Trigger: Red Pack: Green
 Stator White/Green Orange
 Stator: Brown/Blue Stripe (2 wires) Pack: Blue

2 Cylinder Using a Single Ignition Pack and Two Coils & 3 Cylinder Connections:

Color Code Cross Reference

FUNCTION	OLD	NEW
Trigger	Orange	White/Orange Stripe
Trigger	Green	White/Yellow Stripe
Trigger	Red	White/Red Stripe
Trigger	White/Green Stripe	White/Green Stripe

Color Code Cross Reference

FUNCTION	OLD	NEW
Stator	Blue	Brown/Blue Stripe
Stator	Yellow	Brown/Yellow Stripe
Ignition Coil	White	Orange/Blue
Stop (Kill) Circuit	White (Brown)	Black/Yellow

Pack #1 (Firing #1 and #2 cylinders)

Trigger: Orange (White/Orange) Pack: White/Orange Stripe
 Green (White/Yellow Stripe) White/Yellow Stripe
 Red (White/Red) White/Red stripe
 White/Green Stripe White/Green Stripe
 Stator: Yellow (Brown/Yellow Stripe) Pack: Brown/Yellow Stripe
 Blue (Brown/Blue Stripe) Pack: Brown/Blue Stripe
 Coil #1: White (Orange/Blue Stripe) Pack: Orange/Blue Stripe
 Coil #2: White (Orange/Blue Stripe) Pack: Blue/Red stripe

Pack #2 (Firing #3 cylinder)

Trigger: Orange (White/Orange) Pack: White/Orange Stripe
 Green (White/Yellow Stripe) White/Yellow Stripe
 No Connection White/Red Stripe
 No Connection White/Green Stripe
 Stator: Yellow (Brown/Yellow Stripe) Pack: Brown/Yellow Stripe
 Blue (must be connected to the Brown/Blue stripe on pack 1) Pack: Brown/Blue Stripe
 Coil #3: White (Orange/Blue Stripe) Pack: Orange/Blue Stripe

4 Cylinder Connections:

Pack #1 (Firing #1 and #2 cylinders)

Trigger: Orange (White/Orange) Pack: White/Orange Stripe
 Green (White/Yellow Stripe) White/Yellow Stripe
 Red (White/Red) White/Red stripe
 White/Green Stripe White/Green Stripe
 Stator: Yellow (Brown/Yellow Stripe) Pack: Brown/Yellow Stripe
 Blue (Brown/Blue Stripe) Pack: Brown/Blue Stripe
 Coil #1: White (Orange/Blue Stripe) Pack: Orange/Blue Stripe
 Coil #2: White (Orange/Blue Stripe) Pack: Blue/Red stripe

Pack #2 (Firing #3 and #4 cylinders)

Trigger: Orange (White/Orange) Pack: White/Orange Stripe
 Green (White/Yellow Stripe) White/Yellow Stripe
 Red (White/Red) White/Red Stripe
 White/Green Stripe White/Green Stripe
 Stator: Yellow (Brown/Yellow Stripe) Pack: Brown/Yellow Stripe
 Blue (Brown/Blue Stripe) Pack: Brown/Blue Stripe
 Coil #3: White (Orange/Blue Stripe) Pack: Orange/Blue Stripe
 Coil #4: White (Orange/Blue Stripe) Pack: Blue/Red stripe

5 Cylinder Connections:

Pack #1 (Firing #1 and #2 cylinders)

Trigger: Orange (White/Orange) Pack: White/Orange Stripe
 Green (White/Yellow Stripe) White/Yellow Stripe
 Red (White/Red) White/Red stripe
 White/Green Stripe White/Green Stripe
 Stator: Yellow (Brown/Yellow Stripe) Pack: Brown/Yellow Stripe
 Blue (Brown/Blue Stripe) Pack: Brown/Blue Stripe
 Coil #1: White (Orange/Blue Stripe) Pack: Orange/Blue Stripe
 Coil #2: White (Orange/Blue Stripe) Pack: Blue/Red stripe

Pack #3 (Firing #3 cylinder)

Trigger: Orange (White/Orange) Pack: White/Orange Stripe
 Green (White/Yellow Stripe) White/Yellow Stripe
 No Connection White/Red Stripe
 No Connection White/Green Stripe
 Stator: Yellow (Brown/Yellow Stripe) Pack: Brown/Yellow Stripe
 Blue (must be connected to the Brown/Blue stripe on pack 1) Pack: Brown/Blue Stripe
 Coil #5: White (Orange/Blue Stripe) Pack: Orange/Blue Stripe

Pack #2 (Firing #4 and #5 cylinders)

Trigger: Orange (White/Orange) Pack: White/Orange Stripe
 Green (White/Yellow Stripe) White/Yellow Stripe
 Red (White/Red) White/Red stripe
 White/Green Stripe White/Green Stripe
 Stator: Yellow (Brown/Yellow Stripe) Pack: Brown/Yellow Stripe
 Blue (Brown/Blue Stripe) Pack: Brown/Blue Stripe
 Coil #4: White (Orange/Blue Stripe) Pack: Orange/Blue Stripe
 Coil #5: White (Orange/Blue Stripe) Pack: Blue/Red stripe

NOTICE: The color codes listed above may appear on the packs, stators or triggers. Some packs have solid colors and some triggers have striped wires. If you need further assistance, please call our technical support department.

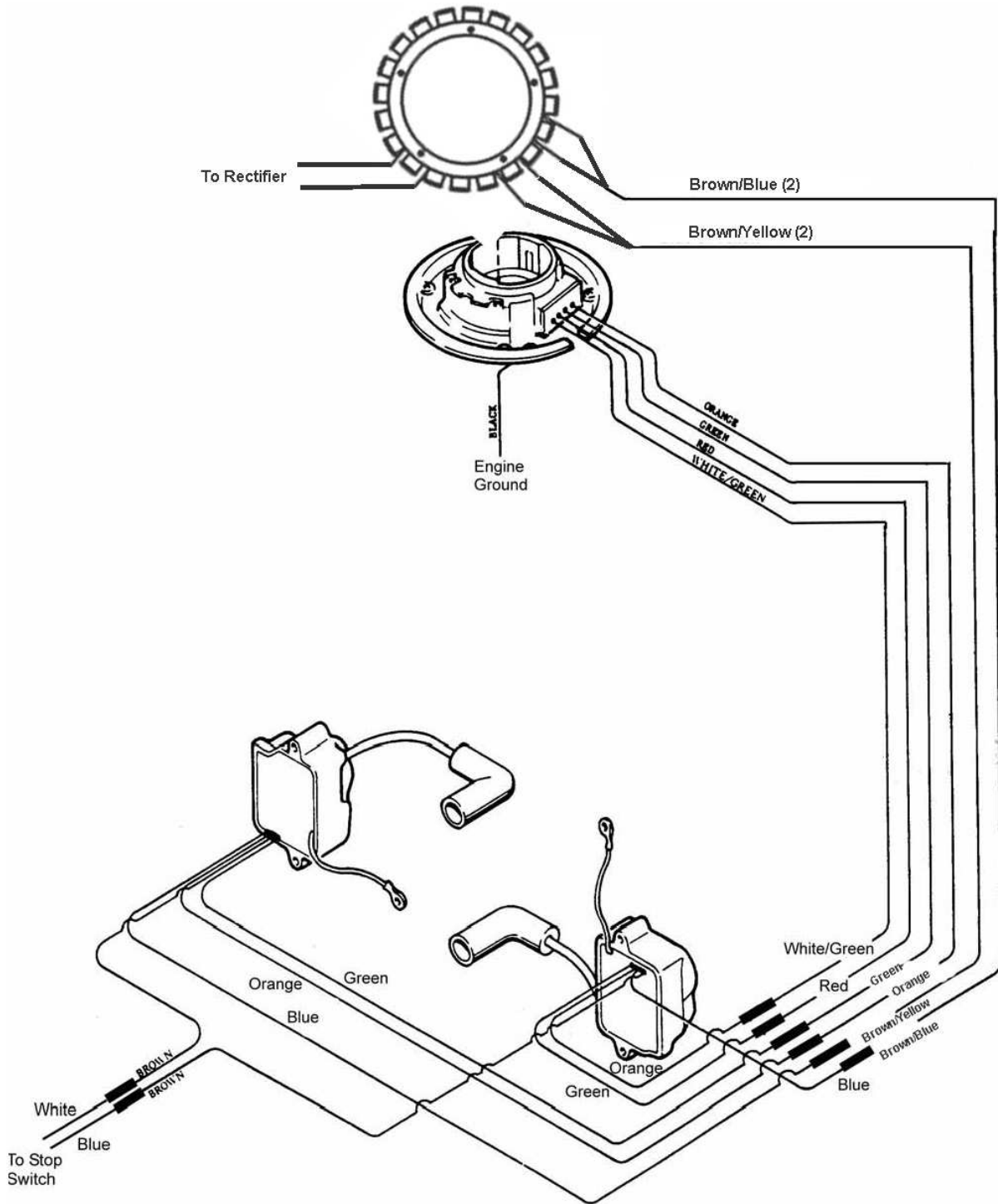

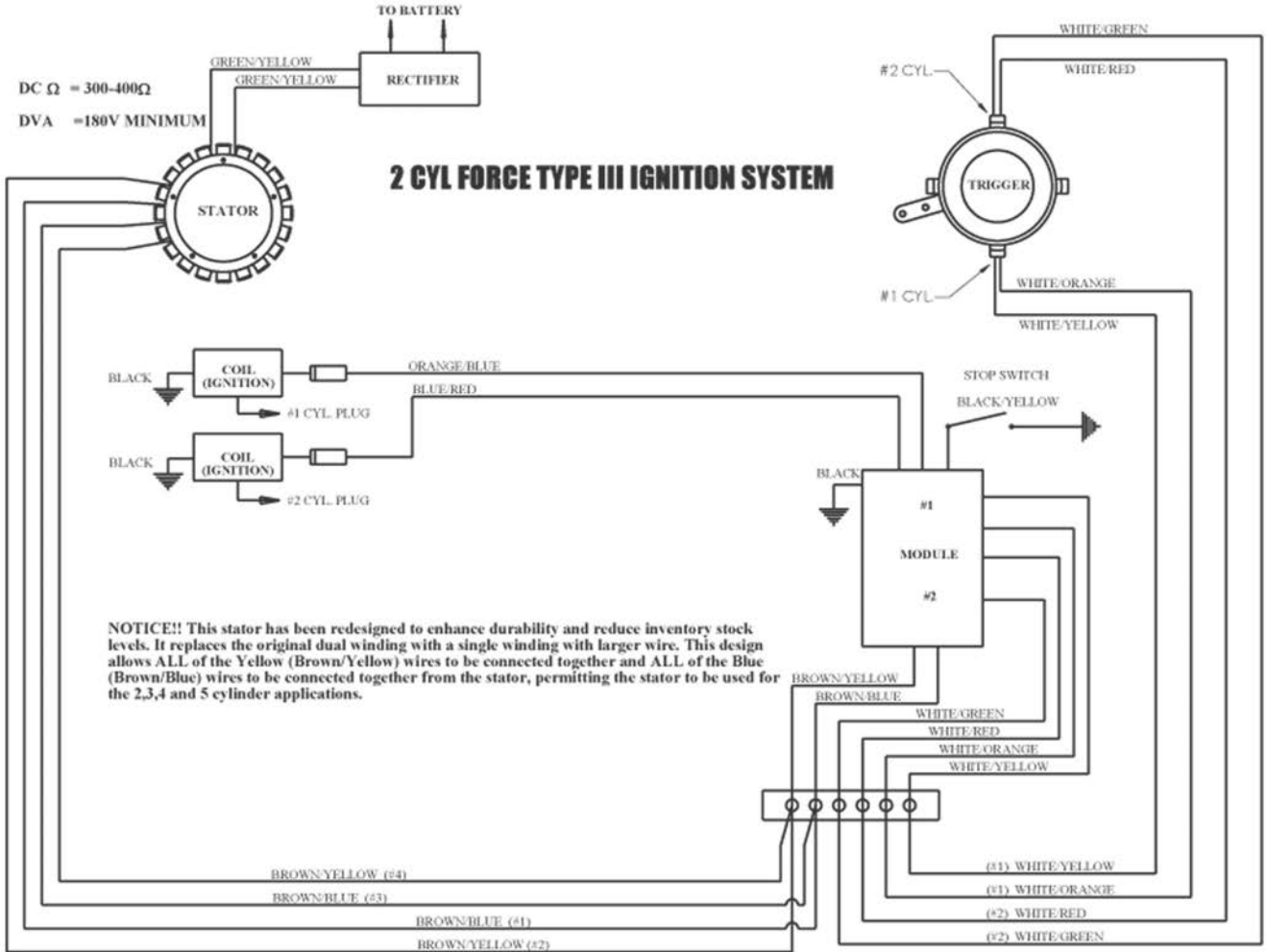

The following wiring diagrams are for reference when using the CDI Electronics triggers:

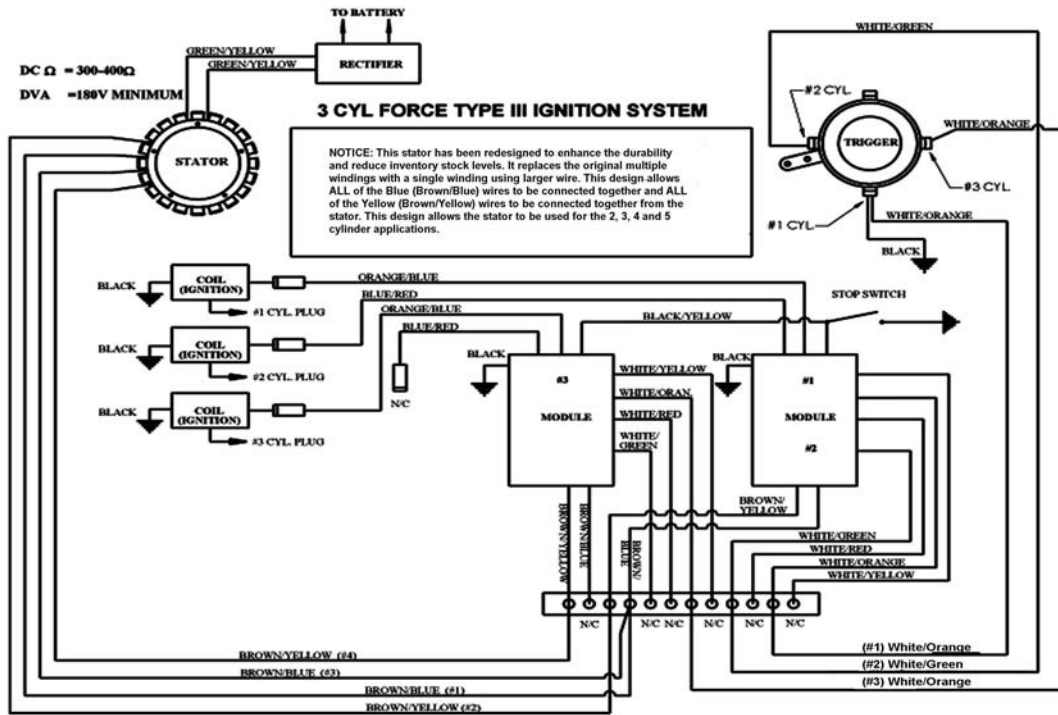

USING OEM TRIGGER AND CDI STATOR

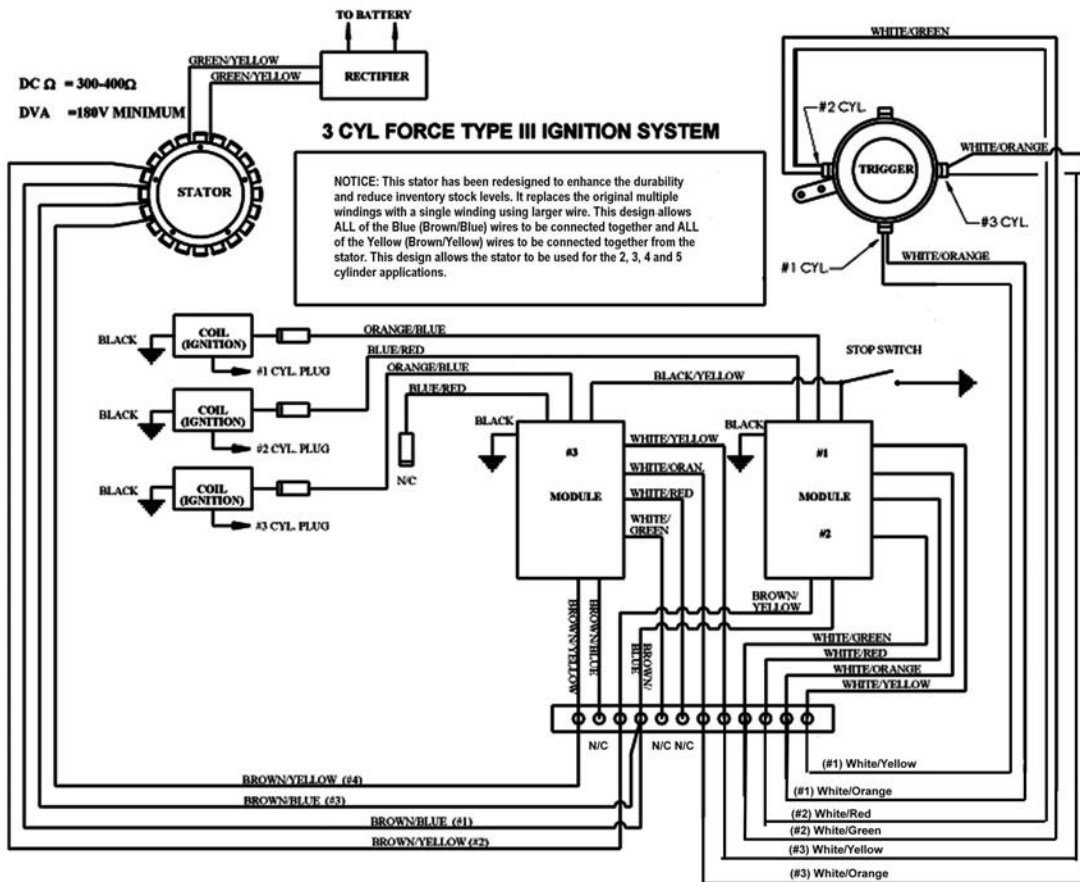

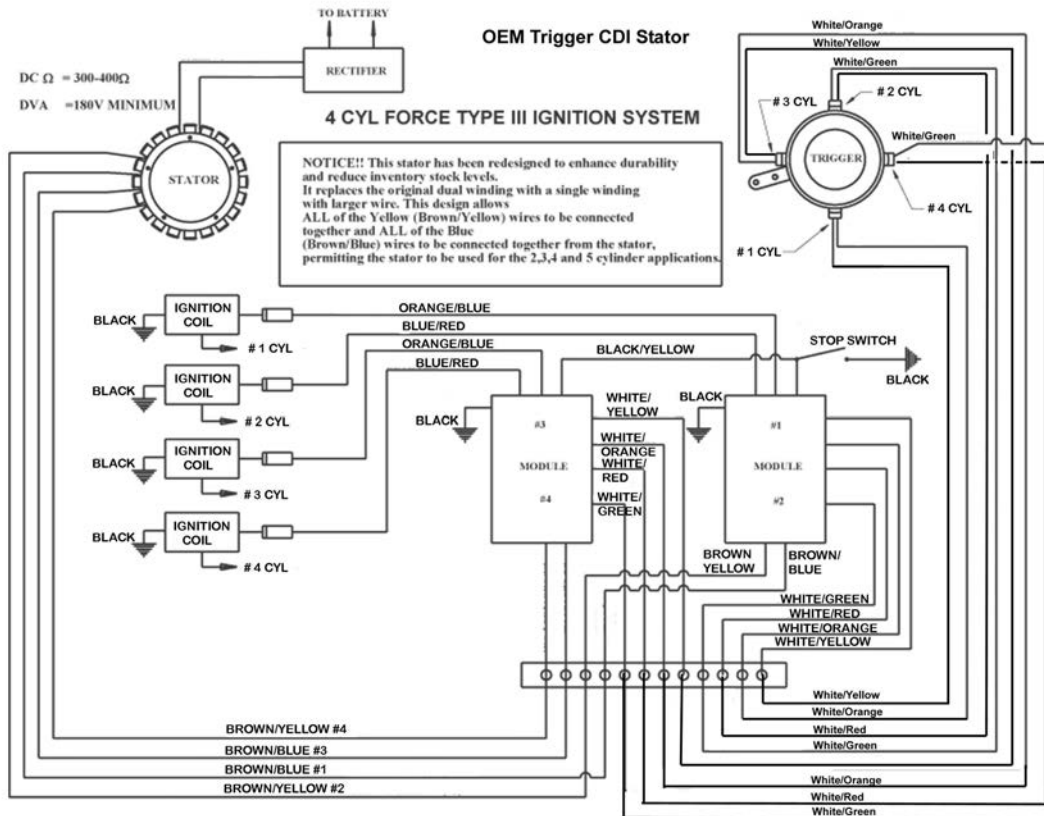
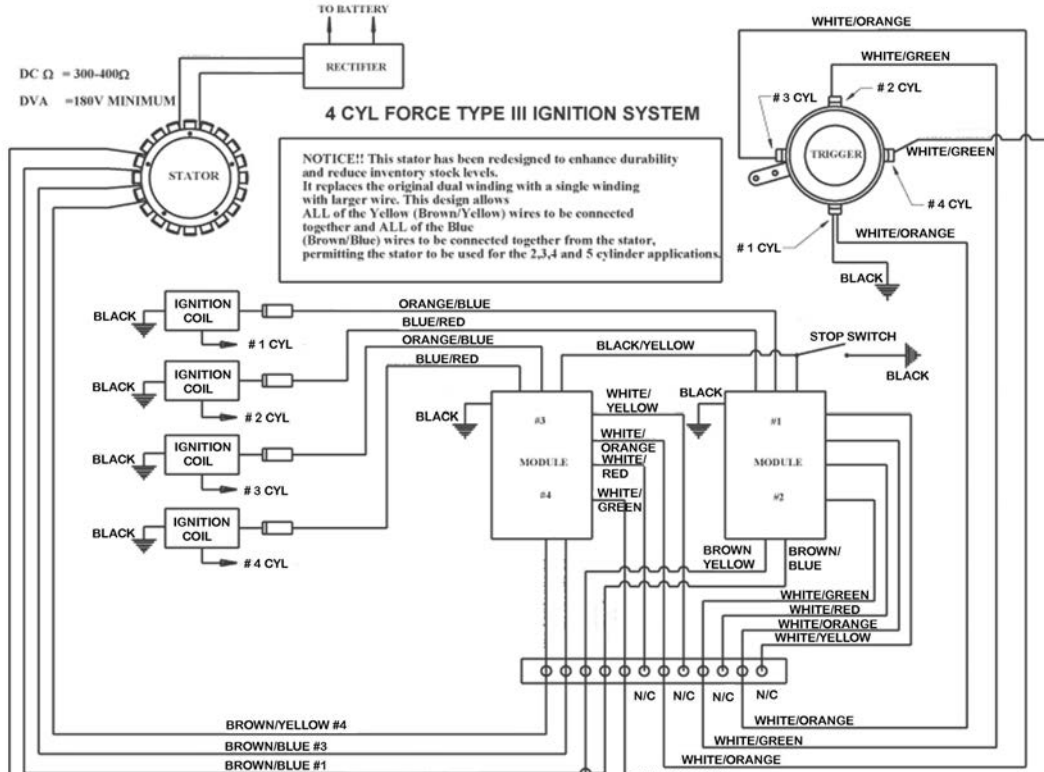

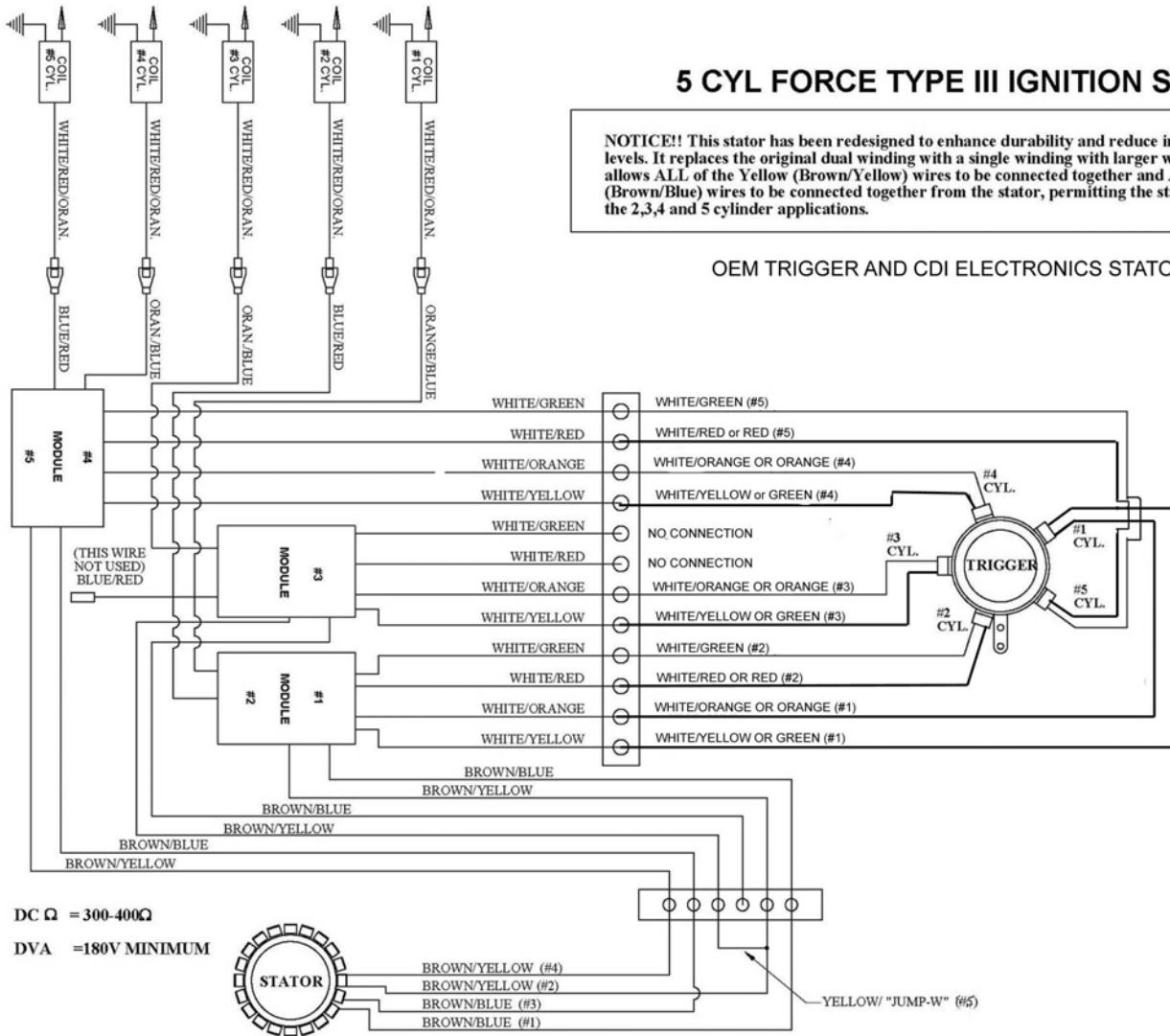

DC Ω = 300-400 Ω

DVA = 180V MINIMUM



BROWN/YELLOW (#4)
 BROWN/YELLOW (#2)
 BROWN/BLUE (#3)
 BROWN/BLUE (#1)

YELLOW/ "JUMP-W" (#5)

