

**CDI P/N: 213-4985K1**

**This unit replaces the following P/N's: 113-6367K 1, 173-4981 and 436367 for Racing Applications**

**WARNING!** This product is designed to be installed by a professional marine mechanic. CDI Electronics cannot be held liable for injury or damage resulting from improper installation, abuse, neglect or misuse of this product. The RPM limit has been reset to 8000 RPM's.

**SERVICE NOTE:** *This kit contains a power pack, special spark plug wires and a replacement sensor. Please use only the Factory Recommended Champion QL78YC (0.30 Gap) Spark Plugs. DO NOT OPERATE ENGINE WITH PLASTIC ENCODER COVER OFF OF THE ENGINE.*

## INSTALLATION

1. Disconnect the battery cables.
  2. Remove timing wheel cover, power pack cover and regulator/rectifier cover (Between the timing cover and the power pack).
  3. Disconnect the stator wire connector from the power pack.
  4. Disconnect the harness wire connector from the power pack.
  5. Disconnect the timing wire connector from the sensor.
  6. Disconnect the spark plug wires from the spark plugs.
  7. Unbolt and remove the ignition coils and old power pack.
  8. Carefully disconnect and remove the throttle linkage connected to the flywheel cover.
  9. Remove the flywheel cover. Watch for the bendix washers and do not lose them.
  10. Remove the screws holding the old sensor assembly in place on top of the flywheel cover and save the screws and spring.
  11. Remove the old sensor from the assembly.
  12. Install the new sensor into the assembly.
  13. Replace the sensor assembly on top of the flywheel cover using the original screws and spring.
  14. Unbolt the flywheel.
  15. Using the correct flywheel puller, remove the flywheel.
  16. Remove the original stator, saving the mounting bolts and grommet on the wire bundle. NOTE: There should be a clip holding down the wire bundle to prevent the wires from getting into the flywheel.  
SERVICE NOTE: At this time, it would be a good idea to replace the bendix bushing in the engine block.
  17. Install the new stator using the original bolts with a good thread-locker applied (CDI 989-3977 is recommended) to the bolts and tightened to the factory torque specifications.
  18. Install the wire bundle grommet on the new stator and route the wires through the notch in the casing. Secure the wire bundle using the clip loosened when removing the old stator.
  19. Replace the flywheel according to the service manual, using new bolts in the hub. USE THE FLYWHEEL REMOVAL TOOL TO HOLD THE FLYWHEEL WHEN INSTALLING IT AS THE MAGNETS WILL GRAB THE STATOR AND JERK THE FLYWHEEL DOWNWARDS –POSSIBLY CAUSING INJURY.
  20. Replace the flywheel cover. Be sure the bendix washers are in place and that the bendix is lubricated.
  21. Carefully connect the throttle linkage connected to the flywheel cover.
  22. Install the new power pack and ignition coils. (Take care not to over-torque the mounting bolts, OEM specification calls for 50-95 in lbs of torque). Make sure the RF Noise Shield is between the ignition coils and the power pack.
  23. Connect the stator and harness connectors to the power pack. Use a small amount of dielectric silicone grease on the connector seal – Do not put any inside the sockets.
  24. Set the ignition timing using the 511-4017 Timing Tool or follow the procedure listed below to set the ignition timing.
  25. Connect the timing wire connector to the sensor.
  26. Connect all spark plug wires to a spark gap tester.
  27. Disconnect the Port temperature switch's Tan and White/Black wires.
  28. Connect a jumper wire to the Tan wire and short it to engine ground.
  29. Connect a timing light to the # 1 spark plug wire.
  30. Connect the battery cables.
  31. Disconnect the engine harness from the boat harness.
  32. Using a piston stop tool or dial indicator, verify the TDC timing pointer's accuracy. Reset as needed to correct.
  33. Use a remote starter (511-6996 is recommended) and verify the ignition timing as follows:

ENGINE	IDLE Timing	WOT Timing
150/175	4-6 Deg ATDC	20 Deg BTDC
100/105/105WR/115JPL	4-6 Deg ATDC	22 Deg BTDC
- NOTE: Adjust the idle timing to adjust the idle speed.
34. Reconnect the engine harness.
  35. Replace the timing wheel cover, power pack cover and regulator/rectifier covers.
  36. Connect the spark plug wires to the spark plugs.
  37. Disconnect the jumper wire from the Tan temp sensor wire.
  38. Connect Tan and White/Black temp switch wire to the temp switch on the Port side of the engine.

39. Using a motor flushing device or in the water, start and run the engine until it reaches operating temperature.
40. Verify the engine's QuickStart function is working by watching for the drop in engine RPM as the engine temperature goes above 105 Deg F and drops the timing back to running mode.
41. Stop the engine and restart it. You should have approximately an 5-10 second period of QuickStart timing advance before the engine settles down to a normal idle.
42. Disconnect the Port temperature switch's Tan and White/Black wires.
43. Connect a jumper wire to the Tan wire and short it to engine ground.
44. Using a motor flushing device or in the water, start and run the engine . Make sure the over-temp alarm is working and try to rev the engine up. You should not be able to exceed 2600 RPM as the engine should go into S.L.O.W. function at 2500 RPM. **Turn the engine off and wait 10 seconds for the processor inside the power pack to reset before continuing.**
45. Disconnect the jumper wire from the Tan temp sensor wire.
46. Connect Tan and White/Black temp switch wire to the temp switch on the Port side of the engine.

## TROUBLESHOOTING

### NO FIRE AT ON ANY CYLINDER:

1. Check the kill lanyard and key-switch position.
2. Verify the engine rotation (The engine needs to be turning in a clockwise direction).
3. Check the power pack and ignition coil ground wires for corrosion and tightness.
4. Connect a spark gap tester to all cylinders.
5. Disconnect the boat side harness and connect a remote starter unit. Check for spark. If the engine has spark, check the boat side harness's Black/Yellow wire for shorts to ground.
6. Disconnect the 5-pin connector on the port side of the power pack and see if the spark returns. If it does, use the Fluke meter set to Ohms and see if the Black/Yellow wires are shorted to engine ground.
7. Check the battery voltage on the Yellow/Red striped wire while cranking the engine. If below 11 volts, charge the battery or check all battery cables.
8. Remove the sensor wheel and check for damage, especially where the top slots are located. Sometimes the wheels will break out where the windows overlap.

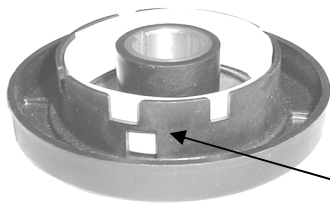

(This area is the most common breakout location)

9. Check the sensor eyes for dirt, grease, etc. If you have to clean it, use denatured alcohol and a Q-tip. Do not use any other cleaning agent because damage to the optical lens will occur.
10. Disconnect the voltage regulator/rectifier and retest. If the engine now has spark, replace the regulator/rectifier.
11. Using the Piercing Probes, check the resistance, then check the DVA voltage on the 6 pin stator connector while connected as follows:

<u>Red Lead</u>	<u>Black Lead</u>	<u>Resistance</u>	<u>DVA Reading</u>
Orange	Orange/Black	50-60 ohms	12 V or more
Brown	Brown/Yellow	450-600 ohms	150V or more
Brown/White	Brown/Black	450-600 ohms	150V or more

Note: Low readings on all checks indicate a possible problem with the flywheel magnets that require checking.

Service note: It is recommended that liquid neoprene be applied to the areas where the piercing probes were used.

12. If all the tests so far show good readings, check the DVA output from the power pack on the primary coil wires as follows:

<u>Red Lead</u>	<u>Black Lead</u>	<u>DVA Reading</u>
Orange/Blue	Engine Ground	130 V or more
Orange	Engine Ground	130 V or more
Orange/Green	Engine Ground	130 V or more

Note: If the DVA values are below these specifications, the power pack or sensor is likely bad.

13. Check the DVA voltage on the Black/Orange and Orange/Red sensors leads as follows:

Red Lead	Black Lead	DVA Reading
Orange/Red	Engine Ground	12 V or more
Black/Orange	Engine Ground	12 V or more

**WARNING!!** The Black/Orange wire should NEVER be shorted to engine ground as this will damage the sensor.

14. If an oscilloscope is available, check the white/blue (crank position signal) and white/green (cylinder position signal) sensor wires while connected to the sensor. With the engine cranking over, you should see a square toothed pattern on both wires. The white/blue wire should show 1 pulse per revolution and the white/green should show 7 pulses per revolution of the engine. See chart below.

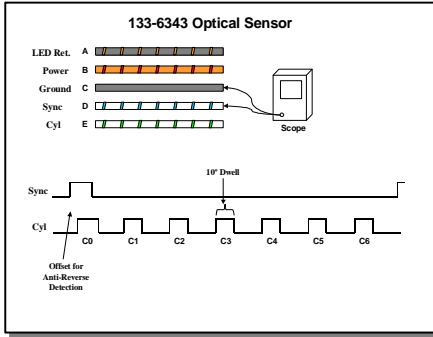

- a. Led Power - Black/Orange
- b. Power - Orange Red
- c. Ground - Black
- d. Sync - White/Blue Stripe
- e. Cyl - White/Green

### NO FIRE ON ONE BANK:

1. Using the Piercing Probes and DVA adapter, check the resistance and DVA voltage for the bank without spark on the 6 pin stator connector while connected as follows:

Red Lead	Black Lead	Ohms Resistance	DVA	Bank/Cyl
Brown	Brown/Yellow	450-600 ohms	150V +	Stbd (1,3,5)
Brown/White	Brown/Black	450-600 ohms	150V +	Port (2,4,6)

NOTE: If the power pack has no spark on one bank and the readings are good, replace the power pack.

2. Disconnect the 5-pin connector on the port side of the power pack and see if the spark returns. If it does, use the Fluke meter set to Ohms and see if the Black/Yellow or Black/Orange wire is shorted to engine ground. Check to see if the Shift Interrupter switch is located in the circuit where there is no spark.

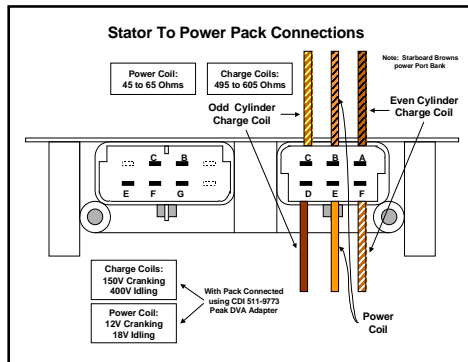

### 6 Pin Connector

- a) Brown/Black
- b) Orange/Black
- c) Brown/Yellow
- d) Brown
- e) Orange
- f) Brown/White

## HIGH SPEED MISS-FIRE:

1. If the engine runs fine until you get above 4900 RPM and then starts missing, check the Orange to Orange/Black power coil wires with an oscilloscope (if available) or check the power coil on the stator. A breakdown inside the pack could cause RFI noise to activate the rev limiter for no apparent reason.
2. Using the Piercing Probes and DVA adapter, check the DVA voltage at the RPM where the problem is occurring while connected as follows:

<u>Red Lead</u>	<u>Black Lead</u>	<u>DVA</u>	<u>Bank/Cylinder</u>
Brown	Brown/Yellow	150V +	Starboard (1,3,5)
Brown/White	Brown/Black	150V +	Port (2,4,6)

NOTE: The readings should rapidly increase as the engine RPM increases and stabilize below 400 volts (voltage exceeding 400 V DVA indicates a bad pack). A sharp drop in voltage right before the miss becomes apparent usually indicates a bad stator charge coil.

3. Connect an inductive tachometer to the spark plug wires one at a time and compare the readings. If most of the cylinders show the same reading and one or two show different readings, check the primary wires with the inductive pickup to see if the readings are the same coming out of the power pack. A difference in readings between the primary and secondary coil wires indicate bad ignition wires. No difference indicates a bad power pack.

## ONLY HAS FIRE AS LONG AS THE STARTER SOLENOID IS ENGAGED:

Using the Piercing Probes and DVA adapter, check the DVA voltage while connected as follows:

<u>Red Lead</u>	<u>Black Lead</u>	<u>DVA</u>
Orange	Orange/Black	11-24V

NOTE: The readings should rapidly increase as the engine RPM increases and stabilize below 24 volts (voltage exceeding 24 V DVA indicates a bad pack). A sharp drop in voltage right before the miss becomes apparent usually indicates a bad stator winding. A sharp drop in voltage when you let off of the starter solenoid indicates a bad power coil on the stator.

## ENGINE WILL NOT REV OVER 2500 RPM AND SHAKES HARD (SLOW ACTIVATED):

1. Verify the engine is not actually over-heating by using a digital pyrometer.
2. Check the routing of the tan temperature wires, an example of a bad location is shown below. The tan wires have to be located as far away as possible from the spark plug wires.

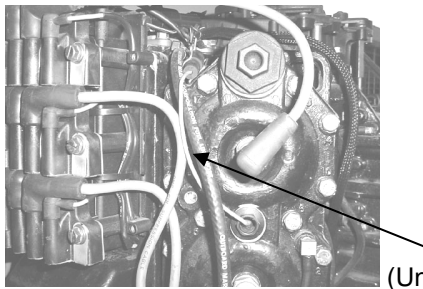

(Unacceptable routing for the temp wire.)

3. Disconnect the temperature sensors and see if the engine performs normally. If it does, check both temperature sensors and replace the defective one.
4. If there is not any indication of a problem at this point, replace the power pack.

## ENGINE STAYS IN QUICKSTART FOR 5 MINUTES WHILE IDLING EVERY TIME THE ENGINE IS STARTED:

1. Check the White/Black Temp wire from the temp sender. It should show a direct shortage to engine ground after the engine reaches 110 degrees F.
2. Short the White/Black Temp wire from the powerpack to engine ground. Restart the engine. The powerpack should drop out within 10 seconds. If so, replace the temp sender.