



# Installation and Troubleshooting Guide

All rights reserved. Reproduction or use of content, in any manner, without express written permission by CDI Electronics, Inc., is prohibited.



## CDI P/N: 511-5207A1 CDM Test Harness

NOTE: The 511-5702A1 CDM Test Harness is for use in checking individual CDM Modules while the CDM Module is connected to the spark plug on the engine.

### All CDM Engines

#### No Fire on One or More Cylinders at Cranking:

1. Check the cranking RPM. A cranking speed less than 250-RPM will not allow the system to spark properly.
2. Connect all CDM Modules to a spark tester, then crank the engine over and watch for consistent spark on all cylinders.
3. Swap the White/Green and Green/White stator wires to see if the problem moves. If it does, replace the stator.
4. Disconnect the black/yellow stop wires from the harness and retest. If the engine's ignition sparks, the stop circuit has a fault- check the key switch, harness and Rev limiter.
5. Disconnect the yellow wires from the stator to the rectifier and retest. If the engine now has spark, replace the rectifier.

#### High Speed Miss:

1. Connect an inductive Tachometer to each cylinder in turn and try to isolate the problem. A high variance in RPM on one cylinder usually indicates a problem in the trigger or CDM module.
2. Disconnect the first suspect CDM Module from the engine harness and connect the engine harness connector to the test harness.
3. Connect the test harness to the CDM Module.
4. Connect a DVA meter from the Green/White wire to the Black wire and record your readings. You should have a minimum of 180V at idle to less than 400V at full speed.
5. Connect a DVA meter from the White/Black wire to the Black wire and record your readings. You should have a minimum of 1 V at idle to less than 40V at full speed.
6. Connect a DVA meter from the Black/Yellow wire to the Black wire and record your readings. You should have a minimum of 180V at idle to less than 400V at full speed.
7. Perform a high-speed shutdown and read the spark plugs. Check for water. A crack in the block can cause a miss at high speed when the water pressure gets high, but a normal shutdown will mask the problem.
8. Remove the flywheel and check the triggering and charge coil flywheel magnets for cracked or broken magnets.

### Two Cylinder Engine

#### No Fire on One or More Cylinders at Cranking:

1. If only one cylinder has spark, swap the Green/White with the White/Green stator wire and see if the problem moves – if it does, replace the stator.

2. If both of the CDM Modules have no spark or are not sparking correctly, test the stator and trigger as follows:

WIRE	Read to OEM	RESISTANCE	CDI RESISTANCE	DVA
White/Green	Green/White	500-700	500-600	180V or more
White wire	Engine GND	Open		1V or more
Brown wire	Engine GND	Open		1V or more

3. Disconnect the suspect CDM Module from the engine harness and connect the engine harness connector to the test harness.
4. Connect the test harness to the CDM Module.
5. Disconnect the Black/Yellow wires bullet connectors in the test harness. If both of the CDM Modules now have spark, the CDM you are connected to is bad and is causing the other CDM Module not to have spark.
6. If the CDM Module under test is the only one with spark, repeat the test for the other CDM Module.
7. If the CDM under test is the only CDM with spark, the stop circuit has a fault, possibly in the ignition switch, harness or rev limiter.
8. Check the resistance of the CDM as follows:

	Red Meter Lead	Black Meter Lead	Reading
CDM Pin #	A	C	700-1300 Ohms
CDM Pin #	D	A	DIODE*
CDM Pin #	D	B	DIODE*
CDM Pin #	A	B	DIODE*
	High Tension Lead	A	700-1300 Ohms

\* Diode readings are to be read one way, then reverse the leads and read again. You should get a low reading in one direction and a higher reading in the other.

9. If the cylinders are only misfiring up above an idle, connect an inductive Tachometer to all cylinders and try to isolate the problem cylinders.
10. The wiring diagram below is furnished in order to help you diagnose the ignition.

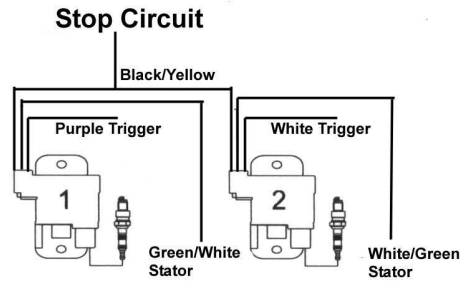

## Three Cylinder Engines

### No Fire on One or More Cylinders at Cranking:

- If all of the CDM Modules have no spark or are not sparking correctly, test the stator and trigger as follows:

WIRE	Read to OEM	RESISTANCE	CDI RESISTANCE	DVA
White/Green	Green/White	500-700	500-600	180V or more
White wire	Engine GND	Open		1V or more
Brown wire	Engine GND	Open		1V or more
Purple wire	Engine GND	Open		1V or more
- Disconnect the suspect CDM Module from the engine harness and connect the engine harness connector to the test harness.
- Connect the test harness to the CDM Module.
- Disconnect the Black/Yellow wires bullet connectors in the test harness. If all of the CDM Modules now have spark, the CDM you are connected to is bad and is causing the other CDM Modules not to have spark.
- If the CDM Module under test is the only one with spark, repeat the test for the other CDM Modules. NOTE: If the CDM under test is the only CDM with spark (all CDM Modules test the same), the stop circuit may have a fault, possibly in the ignition switch, harness or rev limiter.
- Check the resistance of the CDM as follows:

	Red Meter Lead	Black Meter Lead	Reading
CDM Pin #	A	C	700-1300 Ohms
CDM Pin #	D	A	DIODE*
CDM Pin #	D	B	DIODE*
CDM Pin #	A	B	DIODE*
	High Tension Lead	A	700-1300 Ohms

\* Diode readings are to be read one way, then reverse the leads and read again. You should get a low reading in one direction and a higher reading in the other.

- If the cylinders are only misfiring up above an idle, connect an inductive Tachometer to all cylinders and try to isolate the problem cylinders.

### High Speed Miss:

- Use the diagram below to help in locating the area where the problem may be. Remember a short in #1 can cause either #2 and #3 not to have spark. By the same reason, a problem in either #2 or #3 can cause #1 not to have spark.

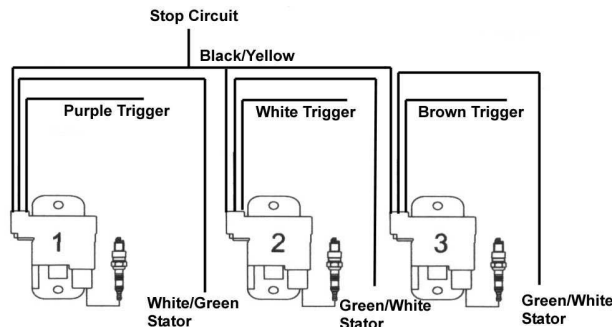

## Four Cylinder Engines

## No Fire on One or More Cylinders at Cranking:

- If all of the CDM Modules have no spark or are not sparking correctly, test the stator and trigger as follows:

WIRE	Read to OEM	RESISTANCE	CDI RESISTANCE	DVA
White/Green	Green/White	500-700	500-600	180V or more
White wire	Engine GND	Open		1V or more
Brown wire	Engine GND	Open		1V or more
Purple wire	Engine GND	Open		1V or more
White/Black wire	Engine GND	Open		1V or more

- If both #1 AND #2 or #3 AND #4 are not firing, disconnect #1 or #2 AND #3 or #4 CDM (if you disconnect a CDM and the rest of the cylinders then spark correctly, the CDM you disconnected is bad). Connect the test harness to the remaining engine harnesses and CDM Modules one at a time and try to identify the problem CDM. If neither of the CDM Modules still connected have a fault, disconnect them and re-connect the CDM Modules you disconnected at first, then repeat the tests for these CDM Modules.
- Disconnect the suspect CDM Module from the engine harness and connect the test harness to the engine harness and CDM Module.
- Disconnect the Black/Yellow wires bullet connectors in the test harness. If all of the CDM Modules now have spark, the CDM you are connected to is bad and is causing the other CDM Modules not to have spark.
- If the CDM Module under test is the only one with spark, repeat the test for the other CDM Modules. NOTE: If the CDM under test is the only CDM with spark (all CDM Modules test the same), the stop circuit may have a fault, possibly in the ignition switch, harness or rev limiter.
- Check the resistance of the CDM as follows:

	Red Meter Lead	Black Meter Lead	Reading
CDM Pin #	A	C	700-1300 Ohms
CDM Pin #	D	A	DIODE*
CDM Pin #	D	B	DIODE*
CDM Pin #	A	B	DIODE*
	High Tension Lead	A	700-1300 Ohms

\* Diode readings are to be read one way, then reverse the leads and read again. You should get a low reading in one direction and a higher reading in the other.

- If the cylinders are only misfiring up above an idle, connect an inductive Tachometer to all cylinders and try to isolate the problem cylinders.

## High Speed Miss:

- Perform a high-speed shutdown and read the spark plugs. Check for water. A crack in the block can cause a miss at high speed when the water pressure gets high, but a normal shutdown will mask the problem.
- Remove the flywheel and check the triggering and charge coil flywheel magnets for cracked or broken magnets.
- Use the wiring diagram below as an aid in locating areas where problems may occur. Remember a short in either #1 or #2 can cause either #3 and #4 not to have spark. Likewise, a short in either #3 and #4 can cause either #1 or #2 not to fire.

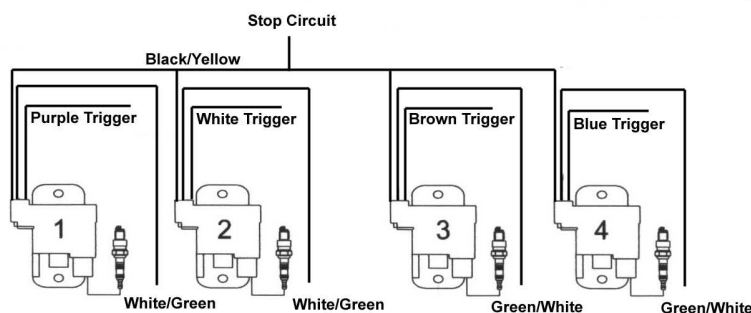

## No Fire on One or More Cylinders at Cranking:

- If all of the CDM Modules have no spark or are not sparking correctly, test the stator and trigger as follows:

WIRE	Read to OEM	RESISTANCE	CDI RESISTANCE	DVA
White/Green	Green/White	500-700	500-600	180V or more
Purple wire	Blue	1100-1400	850-1050	4V or more
White wire	Red	1100-1400	850-1050	4V or more
Brown wire	Yellow	1100-1400	850-1050	4V or more

(Be careful not to damage the pins in the 6 pin plug)

- Disconnect the suspect CDM Module from the engine harness and connect the engine harness connector to the test harness.
- Connect the test harness to the CDM Module.
- Disconnect the Black/Yellow wires bullet connectors in the test harness. If all of the CDM Modules now have spark, the CDM you are connected to is bad and is causing the other CDM Modules not to have spark.
- If the CDM Module under test is the only one with spark, repeat the test for the other CDM Modules. NOTE: If the CDM under test is the only CDM with spark (all CDM Modules test the same), the stop circuit may have a fault, possibly in the ignition switch, harness or rev limiter.
- Check the resistance of the CDM as follows:

	Red Meter Lead	Black Meter Lead	Reading
CDM Pin #	A	C	700-1300 Ohms
CDM Pin #	D	A	DIODE*
CDM Pin #	D	B	DIODE*
CDM Pin #	A	B	DIODE*
	High Tension Lead	A	700-1300 Ohms

\* Diode readings are to be read one way, then reverse the leads and read again. You should get a low reading in one direction and a higher reading in the other.

- If the cylinders are only misfiring up above an idle, connect an inductive Tachometer to all cylinders and try to isolate the problem cylinders.

## No Fire on Top 3 or Bottom 3 Cylinders at Cranking:

- Swap the White/Green and Green/White stator wires to see if the problem moves. If it does, replace the stator.
- Disconnect the CDM Modules one at a time and see if all of the other cylinders then fire correctly.

## High Speed Miss:

- Perform a high-speed shutdown and read the spark plugs. Check for water. A crack in the block can cause a miss at high speed when the water pressure gets high, but a normal shutdown will mask the problem.
- Remove the flywheel and check the triggering and charge coil flywheel magnets for cracked or broken magnets.
- The connection guide below will assist you in locating areas where problems can occur. Remember a short in either #1, #2 or #3 can cause either # 4, #5 and #6 not to have spark.

