



VERNALIFT™

Product Installation Guidelines



WARNING – These are GUIDELINES ONLY and are NO GUARANTEE of a properly designed and installed exhaust system. Centek's products are used in a variety of systems and applications. Therefore, it is impossible for Centek to provide specific installation instructions for all possible configurations of exhaust systems that may be incorporated on a marine vessel by the vessel manufacturer.

IT IS THE RESPONSIBILITY OF THE BOAT MANUFACTURER TO PROPERLY DESIGN AND INSTALL AN EXHAUST SYSTEM APPROPRIATE FOR THE VESSEL IT MANUFACTURES.

The guidelines for the Vernalift™ are as follows:

1. The Vernalift™ is a WET marine exhaust muffler
2. The Vernalift™ is designed for gas/water to flow in one direction only. Please note labels on muffler carefully.
3. Allow sufficient distance between the water injection point and the Vernalift™ to adequately cool the exhaust gases. We recommend a minimum of two feet. Maximum operating temperature should not exceed 350° F. A typical well-designed system should run between 120-188° F.
4. If the exhaust manifold is near or below the waterline, a siphon break must be installed to prevent continued water flow after engine shut down (see Figures 2 and 3).
5. The Vernalift™ should be installed at the lowest point of the exhaust system with the top of the muffler at least 12 inches below the manifold outlet. The possibility of reverse flow of water increases if installed at less than 12 inches. When space constraints do not allow for this height difference, it is strongly recommended that a riser (gooseneck) be installed in the system (see Figure 3).
6. Install the Vernalift™ as close to the centerline of the engine as possible. This will minimize the possibility of cooling water return to the engine in severe angles of heel in sailboats.
7. Making connections:
 - A) Use approved marine exhaust hose for all connections. This will help isolate the muffler and other components from vibration. Do not connect other components to the muffler in a rigid fashion by using adhesives and/or FRP reinforcements.
 - B) DO NOT coat hose or muffler with oil or grease – use water for lubrication.
 - C) Use a minimum of two stainless steel hose clamps per end connection. Tighten clamps by hand with a screwdriver or small wrench. Do not use air wrenches.
8. Add a loop at the outlet side of the muffler that is 18" above the waterline. This may not be necessary for above waterline installations.
9. The outlet hose should run continuously downhill for self-draining. A Centek Vernetone™ inline muffler can be installed in this line for further silencing.

The Vernalift™ is recommended for both gasoline and diesel propulsion and generator engines. It is designed to withstand many times the normal operating pressures. However, this does not mean that it can withstand the extreme instantaneous pressures associated with back-fire.

WARNING! Should a back-fire occur, an immediate and thorough inspection of the entire exhaust system is recommended.

VERNALIFT™

- Product Installation Guidelines -



Warning! Gasoline engines produce dangerous levels of carbon monoxide that will pass through this product as part of a properly designed and installed exhaust system. Per ABYC A-24 Standards, this product must be used in conjunction with working carbon monoxide detectors installed in the boat's living quarters.

FIG. 1 ENGINE INSTALLATION ABOVE WATERLINE

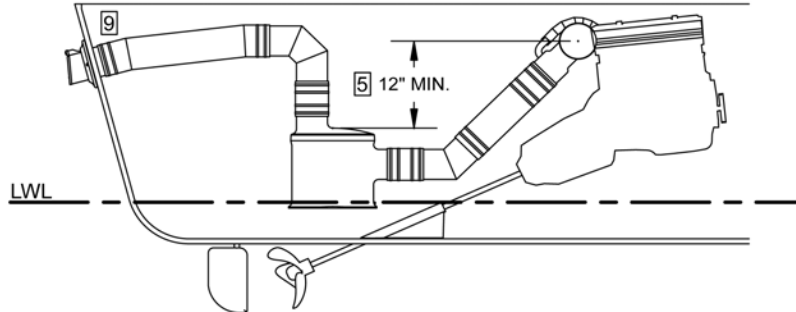

FIG. 2 ENGINE INSTALLATION BELOW WATERLINE WITH SPACE FOR MUFFLER BELOW ENGINE

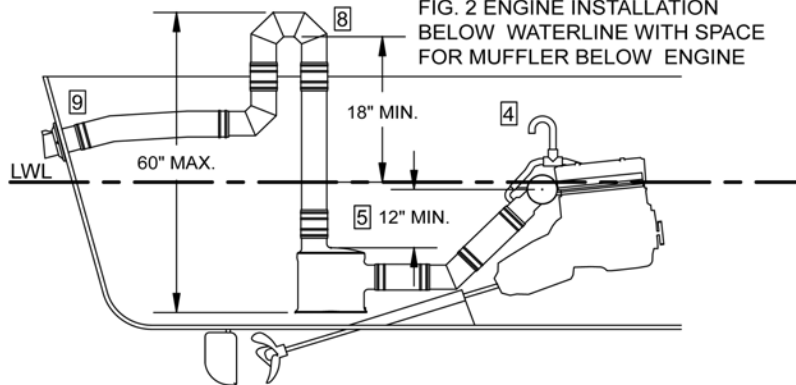
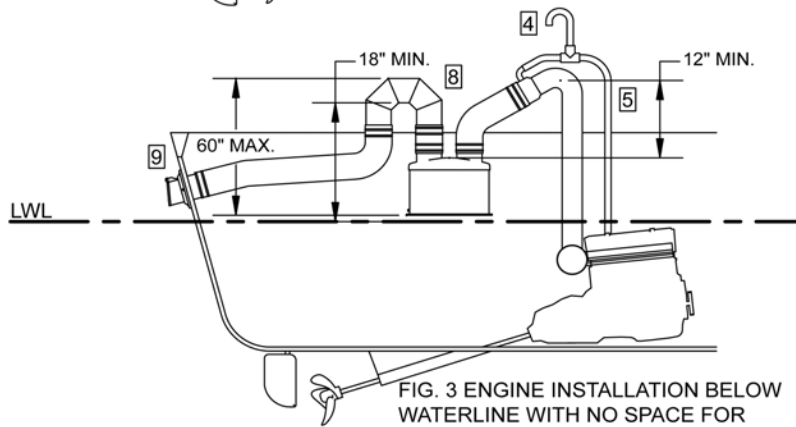

FIG. 3 ENGINE INSTALLATION BELOW WATERLINE WITH NO SPACE FOR MUFFLER BELOW ENGINE



CEN 0