

Daniamant

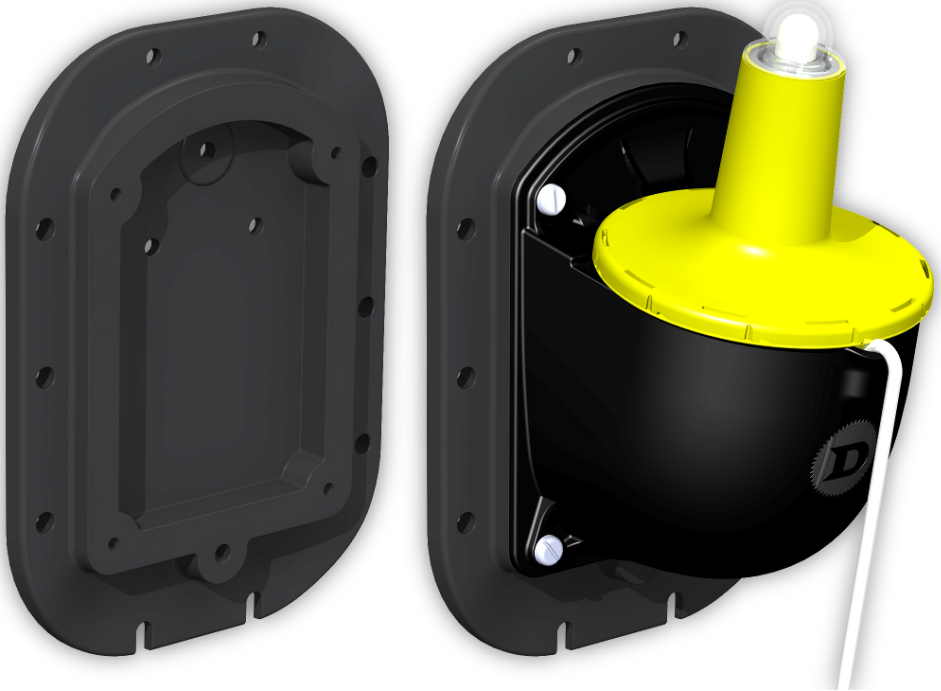

L160, L161, L162 and L163 Mounting Adapter Plate

Installation and Maintenance Instructions



Description

This Mounting Adapter Plate is designed to aid fitting the L160, L161, L162 or L163 bracket using the holes from an existing L40, L41B, L120 or L90 lifebuoy light bracket.

Installation

Remove the existing mounting bracket. If the original fixings are in a serviceable condition, they can be re-used, otherwise replace with new similar fixings.

Align the Mounting Adapter plate with the existing holes, and fix. Make sure that the plate is the correct way up. Refer to the picture on the front of this manual.

Attach the L160, L161, L162 or L163 bracket using the supplied self tapping screws.

Complete the installation in accordance with the instructions supplied with the lifebuoy light.

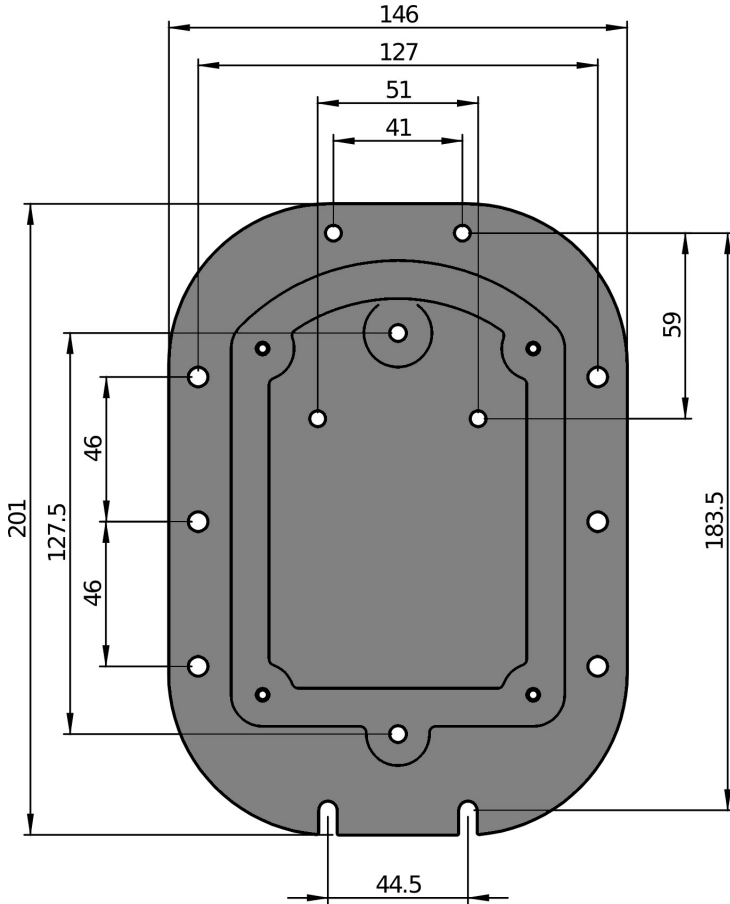

Maintenance

As part of the regular service of the attached lifebuoy light, an inspection of the Mounting Adapter Plate should be conducted.

Make sure that the lifebuoy light bracket is firmly attached to the adapter plate, and that the adapter plate is firmly affixed to the supporting structure.

If any fixing has become loose or damaged, then it needs to be made good. Also, if the adapter plate is damaged such that it would impair its function, then it should be replaced.

Daniamant



L160 and L162 lifebuoy light

Installation and Maintenance Instructions



Description

The L160 and L162 lifebuoy light is a system designed for automatic activation by the act of releasing the lifebuoy to which the unit is attached, such that the battery is activated when the light is pulled from its housing.



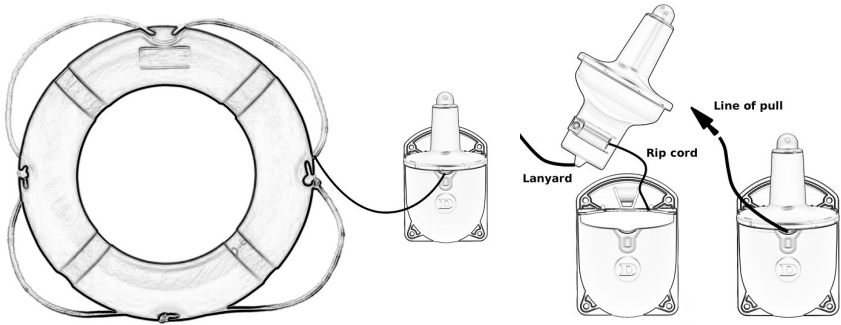

Installation

The L160 and L162 lights should be mounted so that when the lifebuoy is removed a direct pull is exerted on the lanyard thus ensuring that the light is withdrawn from the container and switched on.

Screw the container to a secure location using all four fixing holes provided, making sure that when deployed the drop to the water is not greater than 76 metres. The L160 and L162 Lifebuoy lights have been constructed to withstand a drop into the water from up to 76M, in excess of what is required by LSA Code (Chapter II Section 2.1.1.6).

Secure the lanyard to the lifebuoy. Ensure that the release toggle is fitted to the switch and that the switch is in the off position as shown on page 3. Finally fit the light to the bracket with the lanyard fed over the lip on the front. **IMPORTANT:** The lanyard must feed over the top edge of the bracket as shown to ensure correct release.

Operation

The light is automatically switched on when the lifebuoy is deployed. As the lifebuoy is deployed, the lanyard will lift the light from its mounting bracket. Upon leaving the bracket, the rip cord attached to the switch will switch the light on. When switched on, the light will provide a flashing light of at least 2 Cd. Once the light has been deployed, it must be considered expended and replaced with a new light.

Replacement

The L160 and L162 lights have a storage life of 5 years and must be replaced by the date shown on the label.

Characteristics

	L160	L162
Light output	2 Cd minimum for 2 hours	2 Cd minimum for 15 hours
Dimensions	174mm high x 101mmØ	174mm high x 101mmØ
Weight	Light 190g, Bracket 73g	Light 225g, Bracket 73g
Approvals	SOLAS	SOLAS, USCG

Safety

This light uses Lithium cells. These must be handled correctly:

- Do not dismantle battery pack
- Do not make any external electrical connection
- Do not recharge
- Do not incinerate
- Store between -30°C and +65°C

Maintenance

Routine service

The L160 and L162 is maintenance free, but the following checks should be made periodically (e.g. annually):

1. Inspect visually to ensure the casing is undamaged and that no component parts are missing or damaged. If damaged, the unit is to be replaced.
2. Carefully extract the unit from its housing, taking care not to activate the light.
3. Manually activate the switch slider on the side of the lower portion of the case.
4. Ensure that the light functions. If the light fails to function, the unit is to be replaced.
5. Return the switch slider to the off position to extinguish the lamp, making sure that the release toggle is still attached to the switch.
6. Finally replace the unit into the housing.

Please note there are no user serviceable parts inside this light. If the light fails to illuminate during test, it needs to be replaced. Tampering with the unit will void any warranty.



Release toggle attached, and switch moved to off position.



Replace light in bracket. Ensure lanyard is located in recess.

Spares

The following spares are available to support the L160 and L162

- L160/L162 Bracket. Part Number 62-116
- Adaptor Plate. Part Number 62-070A

Spares are available from our distributors around the world.

Health and Safety information

Daniamant lithium-powered marine safety light systems have a design life of 5 years. The batteries are hermetically sealed pressurised primary Lithium/Manganese cells, and as supplied are electrically protected by a solid state device, and are environmentally protected by a moulded plastic housing. In this condition the units pose no definable hazard to health.

Information on the composition and behaviour of these products is contained in the Product Safety Data Sheet.

Product Disposal Instructions

Daniamant's Survivor Location Lights contain batteries as well as electrical and electronic components, and must therefore be segregated from the domestic waste stream and recycled. Disposing of this product correctly will help save valuable resources and prevent any potential negative effects on human health and the environment, which could otherwise arise from inappropriate waste handling. Daniamant's lights are marked with the symbol below which conveys that this waste must be treated separately from household waste.

To ensure compliance with the WEEE and Battery Regulations, the Survivor Location Lights placed on the market in the UK or Denmark should be returned to Daniamant in the UK or Denmark, or deposited in your nearest WEEE Designated Collection Facility, operated by your Local Authority.

