



BROCHURE

## Lifebuoy Lights L160 - L163

Daniamant design and manufacture all of our products in line with the relevant worldwide approvals, technical specifications, current legislation and International directives.

Our mission is to achieve World class performance through partnerships with our suppliers, customers and employees, providing products and services that enhance the safety and security of our customers.

### Daniamant products cover 11 key areas:

- Lifejacket Lights
- Liferaft Lights
- Lifebuoy Lights
- Intrinsically Safe Lights
  - Special Lights
  - LED Flares
- Bridge Navigational Watch Alarm System (BNWAS)
  - Salinometers
  - Oil Level Alarm
- Electronic Inclinometer
- Agency for a range of world-renowned safety product brands (supplied to the Danish market)

### SOLAS and USCG Approved Lights

The yellow L160 and L161 are SOLAS approved; the orange L162 and L163 are USCG approved. In addition to the above approvals, both L161 and L163 are also approved by ATEX and IECEx and are ETL listed under UL913 which means they are Intrinsically Safe (category 1) and can be used in hazardous zones 0, 1 and 2.

### Fit and Forget

All Lifebuoy Lights offer a five year life. No maintenance or replacement batteries are required. This saves time and expense during inspections.

### Compact size

These Lifebuoy Lights are amongst the smallest and lightest lights available on the market today.

### 76 Metres Drop Height

MED/SOLAS and USCG standards call for the Lifebuoy lights to be dropped from 30 metres. All these Lifebuoy lights have passed a drop height test from 76 metres high. This makes these new lifebuoy lights suitable for use on any platform or vessel with high bridge wings.

### Mounting made easy

All Lifebuoy Lights are supplied with a unique mounting bracket, enabling easy fitting in all locations.

### LED Technology

All Lifebuoy Lights are using the latest advances in LED technology. They feature very low current consumption and enhanced reliability. All our Lifebuoy Lights feature a flashing light.

### Low Cost transportation

These new lights are exempt from transport packing, marking and labelling regulations under surface ADR and IMDG Special provision 188, IATA Packing Instruction 970 Part 1, making shipping easier, quicker and cheaper.



## SOLAS/MED . Minimum 2 hours life and 2 cd output

### L160

The L160 is fully approved to SOLAS/MED standards. The L160 replaces the well established L41B and L120 Lifebuoy lights.



### L161 – Intrinsically Safe

The L161 is fully approved to SOLAS/MED standards and also holds ATEX, IECEx and ETL listing under UL913. It is intrinsically safe (category 1) and as such is suitable for use in hazardous zones 0, 1 and 2. The L161 is our new intrinsically safe Lifebuoy Light and replaces the well- established L40 Light.



## USCG/SOLAS/MED. Minimum 15 hours life and 2 cd output

### L162

The L162 is fully approved to USCG standard UL1196. In addition, it also holds SOLAS/MED approval.



### L163 – Intrinsically Safe

The L163 is fully approved to USCG standard UL1196. In addition, it also holds ATEX, IECEx and ETL listing under UL913 and is approved by SOLAS/MED. It is intrinsically safe (category 1) and as such is suitable for use in hazardous zones 0, 1 and 2. The L163 is the only light to offer all these standards and brings, for the first time, the ability to fit a USCG approved Intrinsically Safe Light to vessels classified under USCG requirements.



*An Adapter Plate is available to make the transition from the older L40, L41B, L90 and L120 to these new Lights much easier. The Adapter Plate mounts on to the existing mounting holes and allows the new Lifebuoy Light to be easily affixed to the Adapter Plate. Order Part Number 62-070A from your Distributor at the same time as you order your new Lifebuoy Light.*





## TECHNICAL DATA SHEET

# Intrinsically Safe Lifebuoy Lights L161 and L163

Daniamant design and manufacture all of our products in line with the relevant worldwide approvals, technical specifications, current legislation and International directives.

Our mission is to achieve World class performance through partnerships with our suppliers, customers and employees, providing products and services that enhance the safety and security of our customers.

### Daniamant products cover 11 key areas:

- Lifejacket Lights
- Liferaft Lights
- Lifebuoy Lights
- Intrinsically Safe Lights
  - Special Lights
    - LED Flares
- Bridge Navigational Watch Alarm System (BNWAS)
  - Salinometers
  - Oil Level Alarm
  - Electronic Inclinator
- Agency for a range of world-renowned safety product brands (supplied to the Danish market)

MODEL	L161	L163
Part number	62-002A	62-004A
Colour – Light Body	Yellow	International Orange
Colour – Bracket	Black: Order 62-116 as Spare Part	
Light – Output	2 Candela minimum	
Light – Duration	2 hours min	15 hours min
Light - Type	Flashing LED	
Material – Lifebuoy Light	Polypropylene Ether + PS	
Material – Bracket	Polypropylene	
Storage Temperature	-30° C to 65° C	
Operating Temperature	-1° C to 30° C	
Storage Life	5 years	
Drop Height	76 metres	
Weight – Nominal	300 grams	320 grams
Battery Type	Lithium Manganese Dioxide	
Activation	Automatic via Pull Cord	
Ex number	Ex ia IIC T4/T3 Ga	
Ex Temperature range	-35° C < Ta < +65° C/+85° C	
Use in Zones	0, 1 & 2	
ATEX Category	1G (Intrinsic safety)	1G (Intrinsic safety)
NATO Stock number	6230 99 366 5928	-
Approvals – Classification Societies	SOLAS/MED/ATEX/IECEX/ETL	SOLAS/MED/ATEX /IECEX/ETL/USCG

## Packing Specification

To minimize shipping costs, all Lifejacket Lights are packed in boxes of 10 off.

### The dimensions are:

Box of 10 off: 58 x 23 x 20 cm

### Approximate packed weights are:

L161: 10 off at 4.2 kg

L163: 10 off at 4.4 kg

TECHNICAL DATA SHEET

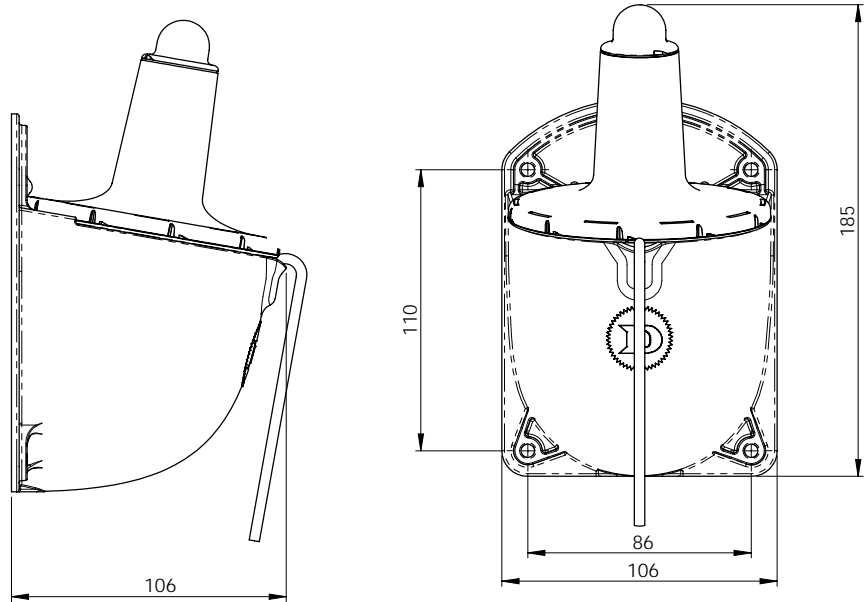

L161/163