

Whale's Tough Lightweight Proven Pump - Tried tested and trusted by sailors for decades

- High flow rate: 105 ltrs (28 US gals) per minute
- Quick maintenance
 - Clamping ring is easily removed for pump head rotation
- Tough, lightweight proven design
- 2 mounting options - bulkhead and thru deck models
- Suitable for use on boats over 12 m (40 ft)

Tips

It is important to ensure that a vented anti-syphon loop is incorporated in the system

Awards and Accreditations

- Suitable as a primary bilge pump on boats equal to or greater than 12 m (40 ft) accordance with ISO15083

COMPLETE YOUR SYSTEM

bilge accessories including non-return valves, elbows and Y pieces see page 40 - 43



Product Information

Model Specifications

| Model | On Deck | Thru Deck / Bulkhead |
|---------------------------------|--|----------------------|
| Product Code | BP4402 | BP4410 |
| Weight | 1.5 kg (3.3 lbs) | 1.85 kg (4.1 lbs) |
| Hose Connections | 38 mm (1½") Smooth Hose Connections | |
| Materials | Pump Body: Glass-filled Polypropylene, Clamp Ring: Acetal Diaphragm and Valves: Neoprene, (Nitrile® option available) Operating Lever: Glass-filled Nylon, Gaiter: EPDM Fasteners: Stainless Steel | |
| Materials In Contact With Fluid | Glass-filled Polypropylene, Acetal, Neoprene, Nitrile® | |
| Service Kits | AK4400 - Neoprene Parts AK4419 - Nitrile® Parts for Oil and Diesel Contains: Diaphragm, Valves, Seals AK4400 - Whale Gusher Titan Neoprene (for on deck installations) - diaphragm, valves and fixings AK4419 - Whale Gusher Titan Nitrile® (for below deck installations) - diaphragm, valves and fixings AS4406 - Whale Gusher Titan - Standard Lever Kit AS4407 - Whale Gusher Titan - Standard Clamping Ring Kit AS4408 - Whale Gusher Titan - Operating Lever U/Deck AS4409 - Whale Gusher Titan - UnderDeck Clamping Ring Kit AS4412 - Whale Gusher Titan - Clamping Plate Kit AS3725 - Gaiter Kit For Deckplates (for underdeck models - Gusher 30 and 10, Titan, Urchin, MarkV) | |
| Accessories | DP8904 - Deck Plate Kit for BP4410 only AS4405 - Spare Handle | |
| Maximum Suction Lift | 4 m (13.5 ft) | |
| Maximum Discharge Head | 4 m (13.5 ft) | |

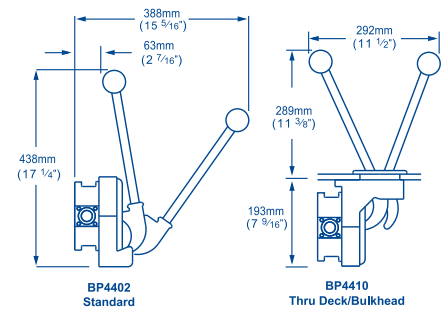

Side View

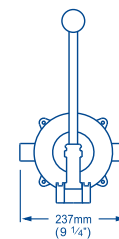

Plan View

Performance Data

| Product Code | BP4402 / BP4410 | BP4402 / BP4410 |
|-----------------------|-----------------------|----------------------|
| Suction Lift | 1 m (3 ft) | 2 m (6 ft) |
| Discharge Head | 0.5 m (1.5 ft) | 0.5 m (1.5 ft) |
| 45 Strokes per Minute | 67 ltrs (18 US gals) | 65 ltrs (17 US gals) |
| 70 Strokes per Minute | 105 ltrs (28 US gals) | 98 ltrs (26 US gals) |

Note: These specifications are retail items only.

Skin fitting 38mm (1½")SF5425

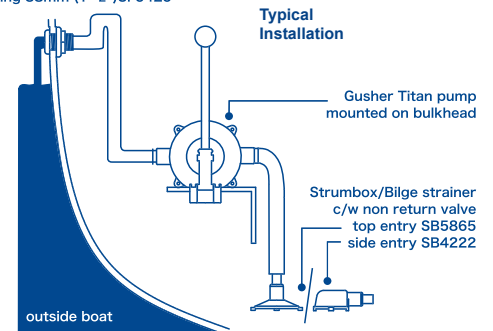

Mk5 Range

Tough proven, reliable designs available with single or double acting capabilities

Whale's most versatile high performance pump design.
3 mounting orientations - 1 pump

Product code: see table

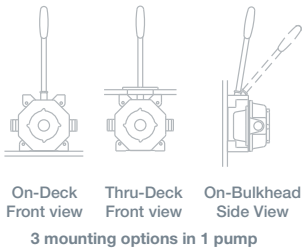
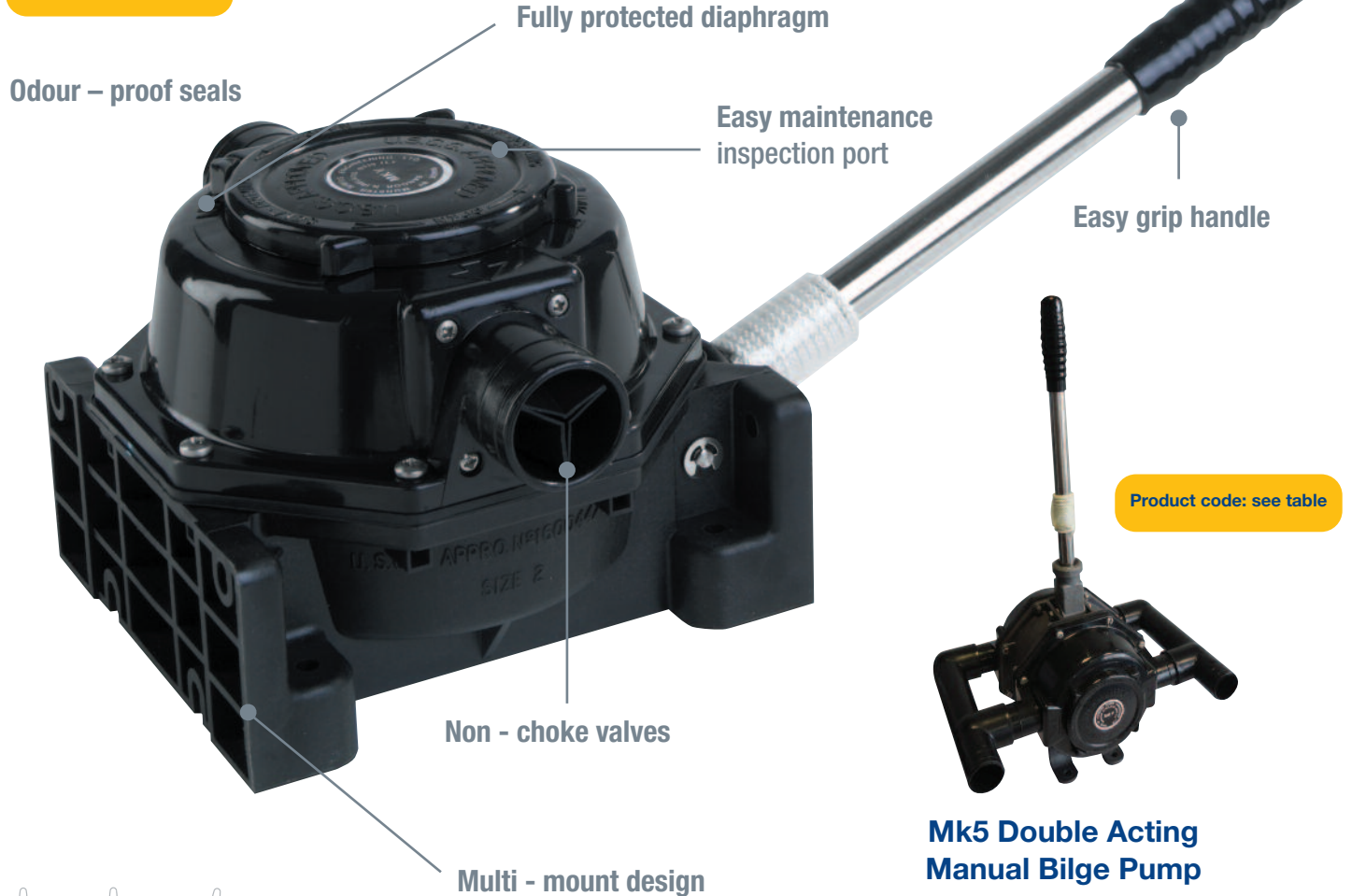

Mk5 Double Acting Manual Bilge Pump

High output - 104 ltrs (23 US gals) per minute
Twin diaphragms - empty 2 bilge compartments at the same time or one twice as quickly - 2 manifolds supplied