

SPL1500

CLASS B AIS

SPLITTER

Installation and instruction Manual



1. Introduction

Congratulations on the purchase of your SPL1500 Class B AIS Splitter. It is recommended that your Splitter is installed by a professional installer.

i This User Manual will provide all of the information you need to install and operate the SPL1500.

2. Before You Start

In the SPL1500 packaging should be the following items;

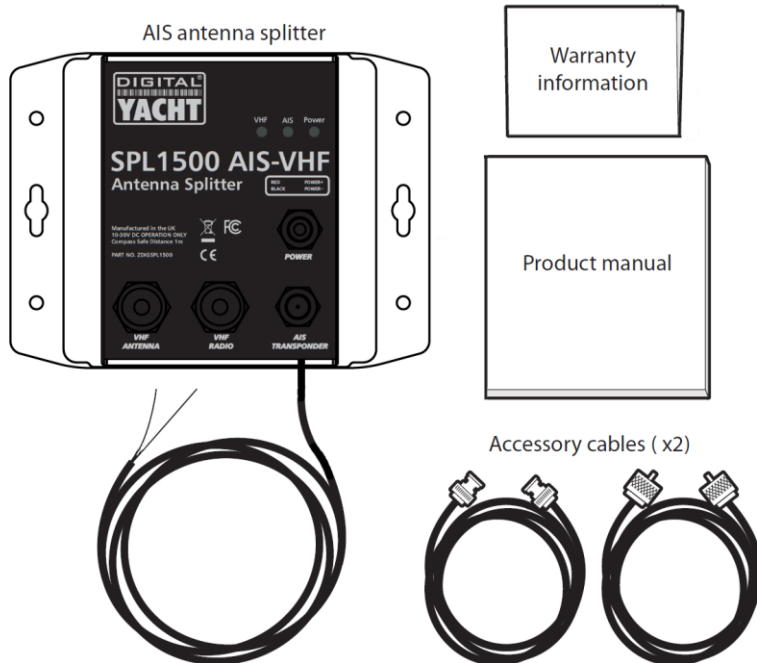

You will need the following items and tools to complete the installation:

- Class B AIS Transponder.
- Pre-installed VHF Antenna and cable.
- Access to 12V DC or 24V DC power supply where the unit is to be installed, via a 1A rated fuse or circuit breaker.
- Connector block or junction box for power connections.
- Four M4 (no. 6) screws or other fixings appropriate to the mounting location.

⚡ *It is not recommended to use this AIS Antenna Splitter with a Class A Transponder, Aids to Navigation Transponder or AIS Base Station..*



3. Installation

Before starting installation select a suitable location for the SPL1500 Class B AIS Splitter. The unit is water resistant; however it should be installed below deck in a dry location. When locating the unit you should consider:

- Routing of power and antenna cables to the unit.
- Provision of sufficient space behind the unit for cable connections.
- Maintaining the compass safe distance of 0.5m.
- Visibility of the front panel indicators.

Installation Diagram

- Below is a typical installation diagram of the SPL1500 being connected to a Class B Transponder.

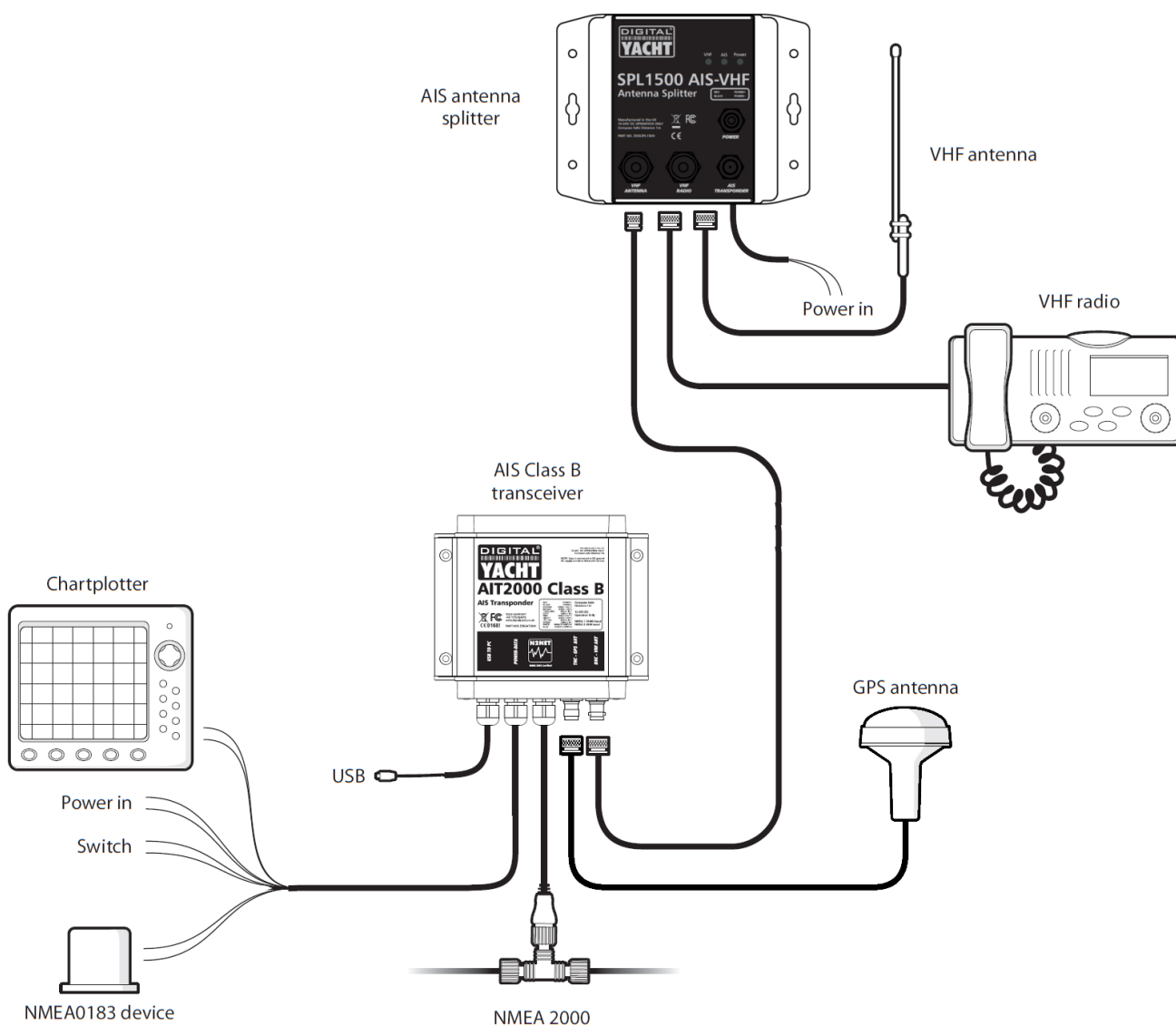



Installation Step 1 – Locating and Fixing the unit

The SPL1500 should be mounted close to the main VHF radio and Class B Transponder, so that the supplied coax cables (0.5m) can connect between the three units. These cables can be replaced with longer versions if necessary but these will need to be sourced from 3rd party retailers, as Digital Yacht do not have any other cable lengths in their product catalogue.

Unit Dimensions

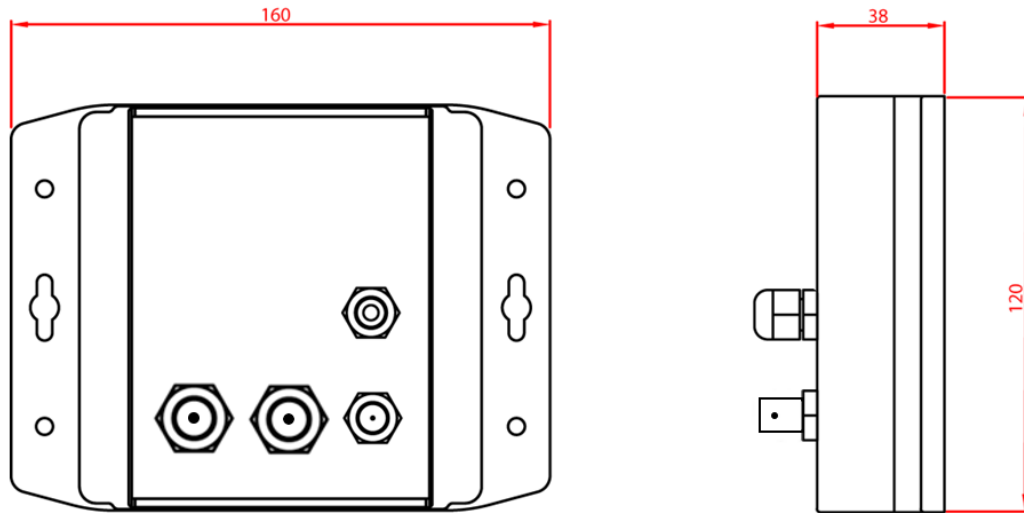

- The SPL1500 should be mounted on a flat solid surface and is most commonly mounted on a vertical bulkhead. However the unit can be installed in any orientation.
- Secure the AIS Splitter in the selected location, using four M4 wood screws or other fixings suited to the material the unit is being fixed to.

Installation Step 2 – Power

- Provide power connections to the unit. Power is connected to the two core “**POWER**” cable on the Red and Black wires. The Red wire is the positive (+) connection. The Black wire is the negative (-) connection.
- Connect the stripped wires to the nearest source of primary 12V or 24V DC power. **Ensure that the supply is connected via a 1A fuse or suitable circuit breaker** (not supplied). Add the fuse in the positive power connection to the unit if necessary.
- The SPL1500 Class B Splitter is designed for 12V or 24v DC systems.
- Do not apply power to the SPL1500, until all antenna and coax connections are correctly made.

Installation Step 3 – Antenna Connections

- The SPL1500 is supplied with two coax cables to connect to a Class B Transponder and VHF radio. One cable is a BNC to BNC cable for connection to the AIS Transponder, while the other cable with the larger PL259 (UHF) type connectors is for connecting the SPL1500 to the VHF radio.
- Ensure you connect the boat’s existing VHF antenna, which will have also have a PL259 connector on it to the correct SO239 connector on the SPL1500.



4. Operation

- Turn on the 12V or 24v power to the SPL1500.
- Ensure the VHF radio and Class B AIS Transponder are turned on.
- Verify that the green **“POWER”** LED indicator on the front of the unit is illuminated,



- Listen to channel 16 or another VHF channel and confirm that you can hear voice communication.
- Press the PTT button on your VHF and ensure that the Yellow **“VHF”** LED indicator on the front of the unit illuminates whilst the PTT button is pressed.
- Watching the Yellow **“AIS”** LED, ensure that at regular 3 minute intervals or 30 second intervals if you are underway (SOG > 2 Knots), the Yellow **“AIS”** LED briefly illuminates when the AIS Transponder transmits its position.
- If your Class B AIS Transponder was supplied with configuration/diagnostics software like proAIS, run this software and check that the Power (SWR) readings are still within the acceptable value range.
- Installation is now complete.

5. Troubleshooting

Problem	Solutions
Power LED not illuminated	<ul style="list-style-type: none"> • Check power supply connections and fuse or circuit breaker. • Check polarity of power supply connections. • Check power supply voltage.
'VHF' LED does not illuminate when VHF Radiotelephone is transmitting.	Check the antenna output of the VHF radiotelephone is connected to the antenna splitter input labelled 'VHF'.
'AIS' LED does not illuminate when AIS Transponder is transmitting.	Check the antenna output of the AIS transponder is connected to the antenna splitter input labelled 'AIS'.
VHF or AIS Transmission is reduced	A small reduction in transmission range is normal and due to the insertion loss of the antenna splitter
Both the "AIS" and "VHF" indicators illuminate when the VHF Radio is transmitting	This is normal operation with some brands of VHF Radio and not a fault. Function of the antenna splitter is unaffected.



6. Specification

Parameter	Value
Dimensions	160 x 120 x 38 mm (L x W x H)
Weight	450g
Voltage supply	DC 9.6 to 31.2V
Current consumption	<150mA at 12VDC
VHF and AIS frequency range	156MHz to 163MHz
Insertion loss AIS & VHF receive paths 0dB	0dB
Insertion loss AIS & VHF transmit paths	<1dB
Max input power, AIS port	12.5W
Max input power, VHF port	25W
Min input power, VHF port	100mW
AIS, VHF and Antenna port impedance	50 Ohms
Switching time, receive to AIS transmit	<10 us
Switching time, receive to VHF transmit	<10us
Operating temperature:	-10°C to +55°C
Ingress protection	IPx5