

### Tools Required:

- 7/16" wrenches or sockets
- Phillips screwdriver

### Recommended Minimum Mounting Hardware

- 5/16" x 2-1/2" Lag bolts & washers (Set of 4)
- Carriage Bolts, nuts & washers (4)

### IMPORTANT:

- Assemble hand rails to step rails prior to securing to the dock surface.
- Assemble tubing as per diagram making sure holes are aligned.

### All Models:

1. Fit step rail tubes (A) over the lower vertical sections of the hand rails (B).
2. Align the screw holes in the hand rails with the holes in the step rails and insert 5/16" machine screws through the holes as shown.
3. Thread a 5/16" lock nut over the protruding threads of the screw. Tighten securely and sufficiently to engage the locking portion of the lock nut.

### Fixed Ladders:

4. Place completed ladder assembly on dock in the desired location. Ladder MUST be mounted with the step rails flush to the dock face. Using the holes in the hand rail mounting plates (C), mark mounting hole locations through the holes and onto the dock. Remove the ladder assembly and drill pilot holes in the locations marked for mounting the ladder onto the dock.
5. Using lag bolts and washers, lag the ladder to the dock at each pilot hole location.

**NOTE:** Softwood docks such as cedar should have holes drilled through the dock and carriage bolts, washers and locking nuts used to secure the ladder to the dock.

### Flip-Up Ladders:

4. Place completed ladder assembly on dock in the desired location. Ladder MUST be mounted with the step rails flush to the dock face.
5. Mark the location of the back and side edges of the hinge plates (D) onto the dock surface with a pencil.
6. Swing the ladder assembly up to expose the mounting holes of the hinge plates. Position the hinge plates with the pencil marks previously made on the dock and mark the location of the mounting holes on the dock.
7. Remove the ladder assembly and drill pilot holes in the locations marked for mounting the hinge plates onto the dock.
8. Using lag bolts and washers lag the hinge plates securely to the dock at each pilot hole location.

**NOTE:** Softwood docks such as cedar should have holes drilled through the dock and carriage bolts, washers and locking nuts used to secure the ladder to the dock.

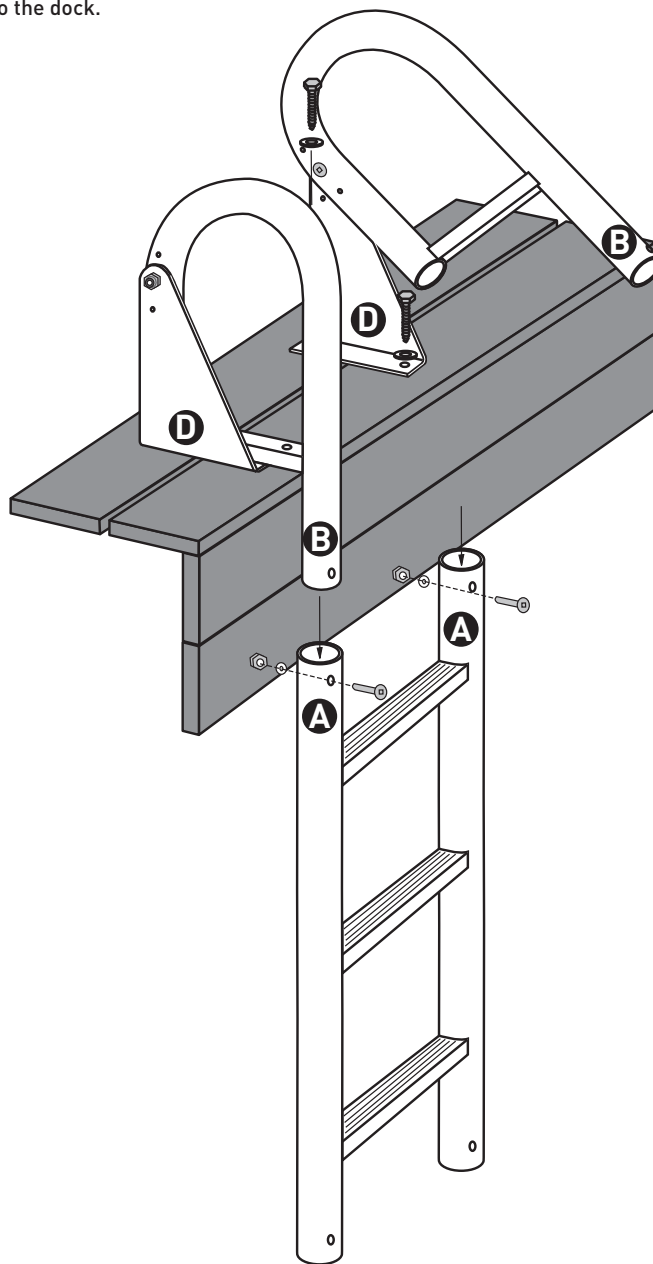
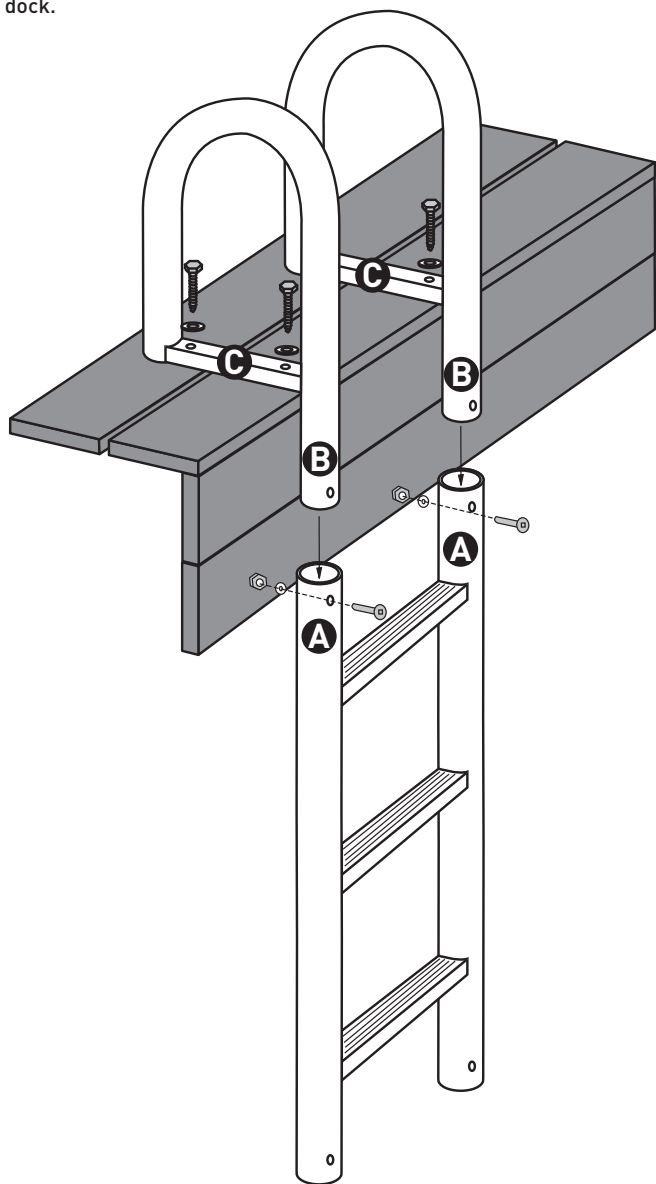

**CAUTION:** Failure to follow proper installation instructions may lead to product failure and personal injury. Ladder must be mounted flush with the dock face board. Regularly inspect for wear or damage. Replace as necessary. (DO NOT EXCEED THE LADDERS' MAXIMUM CAPACITY OF 665LB. (302KG))