

*...a significant advance in marine safety!*

# ECHOMAX

## Active-XS-Dual Band

### Radar Target Enhancer

#### OPERATION MANUAL



*Echomax Active-XS-Band RTE shown with optional Stainless Mast Bracket*

**FCC CERTIFICATION ID: XZMACTIVE-XS**

**CE 0191** ⓘ

**NATO STOCK NO.5841-99-269-3512**

**TURKISH PERMISSION REP: B.62.0.BTK.0.11.244.02/17595/8059**



## OPTIONAL EXTRAS

### FLUSHMOUNT WATERPROOF CONTROL BOX

New slim line flush mount waterproof control box features:

- Keypad operation: X or X & S Band LED to match your single or dual band RTE
- Selectable audio alarm sensitivity
- Selectable day or night time illumination brightness
- Extension alarm facility

#### DIMENSIONS

- Control Box width: 90mm
- Control Box height: 72mm
- Control Box depth: 50mm (excluding provision for cables)
- Cut out diameter is 57mm



### STAINLESS STEEL MOUNTING BRACKETS

- 100mm Base fitting: male 1 inch – 14 NF thread
- 200mm Base fitting: male 1 inch – 14 NF thread
- 60cm Stainless Steel Extension Pole: female / male 1 inch 14 NF thread to take the RTE above the vessels radar.
- Mast Bracket: 26cm reach and male 1 inch – 14 NF thread



### FLUSH MOUNT KIT FOR CONTROL BOX

Length: 111mm Height: 70mm



Specifications given in this manual are subject to change without notification.

## Active X Test 8-13

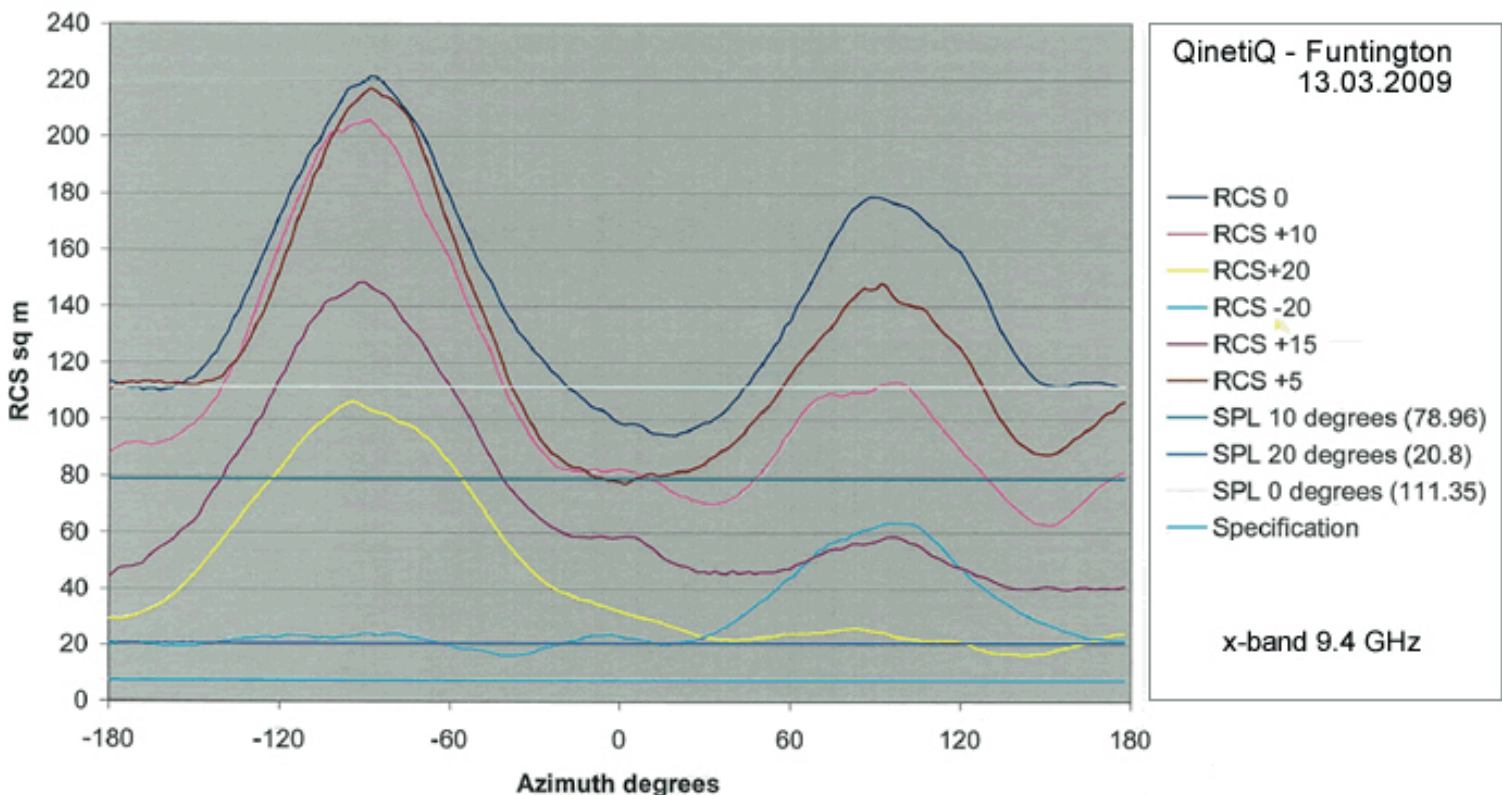

# ECHOMAX

## Active-XS-Dual Band

### Radar Target Enhancer

#### GENERAL INTRODUCTION

The Echomax Active-XS-Dual Band Radar Target Enhancer (RTE) is designed to respond to interrogating both X (9.3 - 9.5 GHz) and S band radar (2.9 - 3.1 GHz) by receiving a transmitted pulse, amplifying and re-transmitting the pulse back to the radar at the same frequency with minimum delay, thereby improving the radar detection range and visibility of small targets. It will not enhance significantly vessels with large radar cross section. The Active-XS-Dual Band Radar Target Enhancer is suitable for all vessels up to 150 gross tonnage.

SOLAS V Regulation 19 2.1.7 states (Radar reflector):- All ships irrespective of size shall have, if less than 150 gross tonnage and if practicable, a radar reflector, or other means to enable detection by ships navigating by radar at both 9 GHz (X Band) and 3 GHz. (S Band). The Active-XS-Dual Band Radar Target Enhancer will typically enhance the RCS (radar cross section) of vessels up to 25M in length. For small craft/rigid inflatables improvements will start to be seen at around 1-2 miles extending to 8-10 miles or more depending on prevailing conditions.

The response of the RTE will vary according to range, RTE and radar height above sea level, radar power and condition. Poor weather, sea state and precipitation will greatly reduce the response.

#### IMPORTANT

The fitting of the Echomax Active-XS-Dual Band RTE does not exclude you from exercising safe navigational judgement for your vessel under the International Regulations for the Prevention of Collisions at Sea and to keep a proper look out at all times.

#### LICENSING REQUIREMENTS

Many countries and administrations require a ships radio license or modification of your existing ships radio licence before Active-XS can be used for maritime use. Contact your local administration for details.

#### ECHOMAX ACTIVE-XS COMPONENTS, CONSTRUCTION, use and installation

If you are not able to safely install the unit yourself you are advised to seek the services of a competent person or company to install the RTE.

#### COMPONENTS

Echomax Active-XS mast head radome fitted with 25 meters of 3 core cable  
Control Box  
Operation Manual

#### RADOME FITTING

The antenna has provisions in the base for a 1 inch -14 NF female thread mast fitting or deck mount bracket. Plastic mounts should not be used. To ensure a permanent fixing 'LOCTITE' or PTFE or plumbers tape should be used and the RTE must be screwed down tightly. Care must be taken to ensure that as the RTE is tightened on the base the cable is allowed to turn freely.

For mast fitting the radome should be fitted vertically at masthead or as illustrated on the following page. The transmit antennas are positioned 70mm from the base of the radome and need a clear 360 degree azimuth. When fitted at mast head keep as far away as possible from other fittings to reduce shadowing using the Echomax mast bracket. The radome will not interfere electrically with other mast head fittings. It should not be fitted on a back stay or where its vision is obscured or is close to any metal object otherwise performance could be significantly impaired.

The radome unit must never be painted as this will seriously impair performance. The radome must not be fitted in or close to the vessels radar transmitting beam width of 28 degrees as this may seriously damage the PCB. The RTE can be fitted

below or preferably above the radar. It is possible to shorten or extend the cable by a further 25 meters without affecting the performance using extension cable rated at 3A at 300V.



#### ECHOMAX CONTROL BOX for surface fitting or flush mount fitting with optional flush mount kit

The control box must be fitted internally as it is not waterproof and can be wired from the base or back as required. A 12v fused or circuit breaker supply of 3-5A is required.

The control box has a quadruple alarm facility. Once the red power switch is turned on the unit is in the quiescent mode and will consume up to 23mA. When interrogated by an X Band radar the green LED light will flash every 2.4 seconds. If the flash lengthens then this indicates that more than one radar is painting the antenna. If painted by a high speed radar which rotates every 1.5 seconds then the LED light will flash quicker. When painted by an S Band radar the yellow light will flash. It should be borne in mind that vessels with S Band radar are very large and in most cases over 3000GT and can neither stop nor change course quickly. Turning on the green switch will mobilize the internal buzzer, which is set to actuate for approximately half a second intervals. The control box also has facilities for a 8A external volt free alarm. THIS IS NOT A POWER SOURCE and must be initialised as shown in the wiring diagram. The control box has an externally replaceable 0.5A fuse and is surge and cross polarity protected. NB - ISOLATE POWER SUPPLY during installation, alteration or repair of wiring.

#### REMOVAL OF FUSE

Gently push fuse in and turn anti-clockwise and then remove. Failure to do this will damage the aluminium connections.

# RTE CONNECTIONS The diagrams show the correct wiring installation

## BASIC OPERATION – NO EXTERNAL ALARM

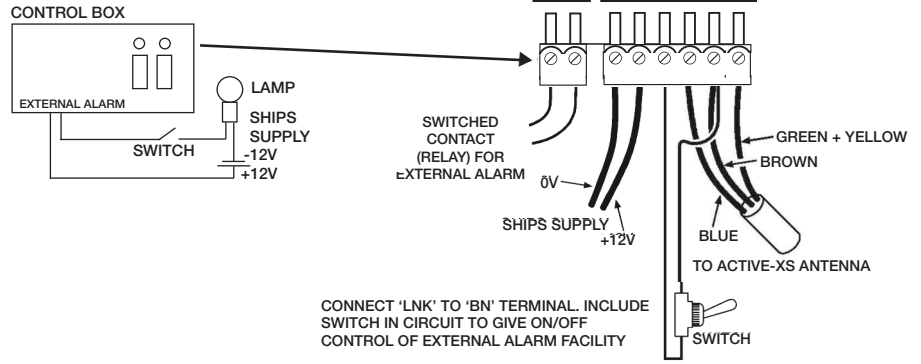
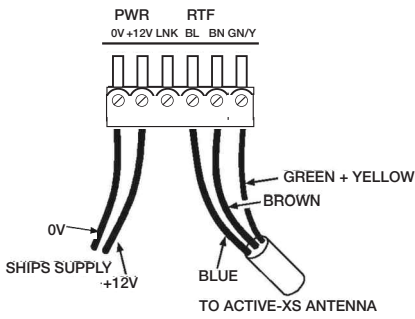

## PERFORMANCE CHECK

As the RCS of your vessel may exceed the RCS of the RTE, the trial is best carried out at 0.5 nm as the target can be easily identified. The range should then be increased at intervals of 0.5 nm and the RTE switched on and off noting the change in response. As the range increases the bare target will not be seen and whilst moving the RTE is left on so that the test target can be seen at all times. This is important in busy waters to avoid confusion with other vessels.

If the target is lost it can be acquired by turning the RTE on and off and watching the display for change in target response. In normal weather and sea conditions, with RTE and interrogating radar mounted at four meters above sea level should respond on the radar screen as shown below. If the mounting heights, including that of the interrogating radar vary so will the response due to curvature of the earth. These figures are for guidance

only and should not be relied upon.

2KW radar up to 4 nm : 5KW radar up to 10 nm :  
10-25KW radar up to 15-30+ nm

**DO NOT EXPECT** to always see by the naked eye the vessel or land based interrogating radar which may be +/- 30 miles away and principally below the horizon. Reports of 60 miles reception have been recorded.

## ACTIVATION BY VESSELS OWN RADAR

It is to be expected that use of the vessels own radar will illuminate the green and possibly the yellow LED. The RTE will treat this as a third party radar and will continue to receive and respond to all other radar.

## FAULT FINDING CHART

No Red LED light when red switch is turned on	Check fuse or circuit breaker Check polarity of wiring Check power supply at control box	Damaged cable or wrong connection Cable cut with power on check fuse
Unit switched on and continuous green LED light shows, in harbour or when saturating RTE	Local radar on, or radar operating moored nearby (<15M) Moored close to large metal object Relocate vessel to more suitable position	Check polarity of radome wiring
Unit on and buzzer on and unit fails to operate when it clearly is interrogated	Check all above faults. Is RTE in shadow of interrogating radar as it will not operate if masked	
Buzzer switched on but does not sound when painted by radar	Buzzer faulty – return control box to Echomax for inspection	

## TECHNICAL SPECIFICATION

Reception frequency: X Band Radar 9.3 - 9.5 GHz  
S Band Radar 2.9 - 3.1 GHz

Operating Temperature: - 20 to + 60 degrees C

Voltage: 12V DC - + 30% - 10% (voltage surge and cross polarity protected)

Current consumption in quiescent state: <23mA

Current consumption when transmitting: X Band Radar 190mA (typically)  
S Band Radar 155mA (typically)

Position accuracy: Within 1 metre

EIRP: 1W (typically)

### DIMENSIONS and WEIGHTS

Antenna length: 685mm

Antenna width: 40.5mm

Antenna weight: 573gms (excluding cable)

Control Box width: 92mm

Control Box height: 51mm

Control Box depth: 38mm

Control Box weight: 99gms

Cable length: 25m 3 core 0.5mm<sup>2</sup>

Cable weight: 967gms

### STATED PERFORMANCE LEVEL (SPL)

Exceeds ISO 8729-2 effective July 09 - X Band Radar 7.5m<sup>2</sup> and S Band Radar 0.5m<sup>2</sup> at Zero, +/-10 and 20 degrees of heel maintained over a total angle of 280 degrees.

Typical performance – QinetiQ Funtington Anechoic Chamber March 2010

<b>X BAND RADAR SPL</b> (ISO Standard 7.5m <sup>2</sup> )	<b>S BAND RADAR SPL</b> (ISO Standard 0.5m <sup>2</sup> )
Zero degrees: 118.33m <sup>2</sup>	Zero degrees: 6.26m <sup>2</sup>
+/- 10 degrees: 65.07m <sup>2</sup>	+/- 10 degrees: 6.44m <sup>2</sup>
+/- 20 degrees: 19.49m <sup>2</sup>	+/- 20 degrees: 5.36m <sup>2</sup>

NB. Production units have the following S Band SPL

Zero degrees: 15.75m<sup>2</sup>

+/- 10 degrees: 16.20m<sup>2</sup>

+/- 20 degrees: 13.40m<sup>2</sup>

## MOUNTING

Base fitting: female  
1 inch – 14 NF thread

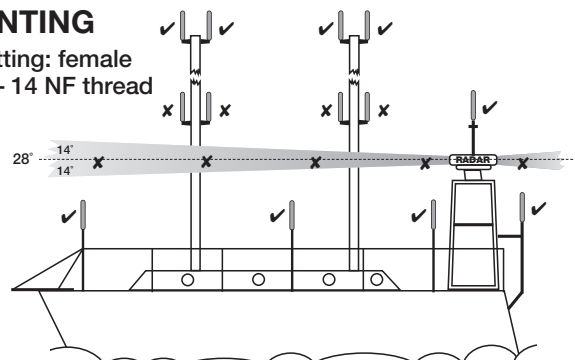

RTE Mast top – horizon (not response) +/- 25 miles

Pushpit – horizon (not response) +/- 4–6 miles.

Lower installations may require trial and error to find the best location and may be subject to slight shadowing.