



Caution

Disconnect the battery during installation. Tighten nuts on the backclamp only slightly more than you can tighten with your fingers. Six inch-pounds of torque is sufficient. Overtightening may result in damage to the instrument and may void your warranty.

Note

To change light bulb, twist black socket assembly one-eighth turn counter clockwise until it pops out. Bulb pulls straight out of assembly. Use a GE No. 161 instrument lamp for replacement.

Installation

1. Be certain to use stranded, insulated wire not lighter than 18AWG that is approved for marine use. It is recommended that insulated wire terminals, preferably ring type, be used on all connections to the gauge, except the light which requires a 1/4" insulated blade terminals.
2. Cut a 2-1/16" dia hole in the dash and mount the gauge with the backclamp provided.
3. Connect a wire to the gauge stud marked "-" (ground) and secure with a nut and lockwasher. Connect opposite end to the boat's electrical ground, generally available in several locations at or near the instrument panel.
4. Connect a wire to the gauge stud marked "+" (positive) and secure with a nut and lockwasher. Connect opposite end to any continuous B+ or positive "+" circuit of the boat's 12VDC electrical system. This circuit must not be ignition key activated as the clock requires a very small but continuous B+ current supply.
5. Connect the blade terminal adjacent to the twist-out light assembly to the positive "+" side of the instrument lighting circuit. No separate ground is required for lighting.

Wire Connections

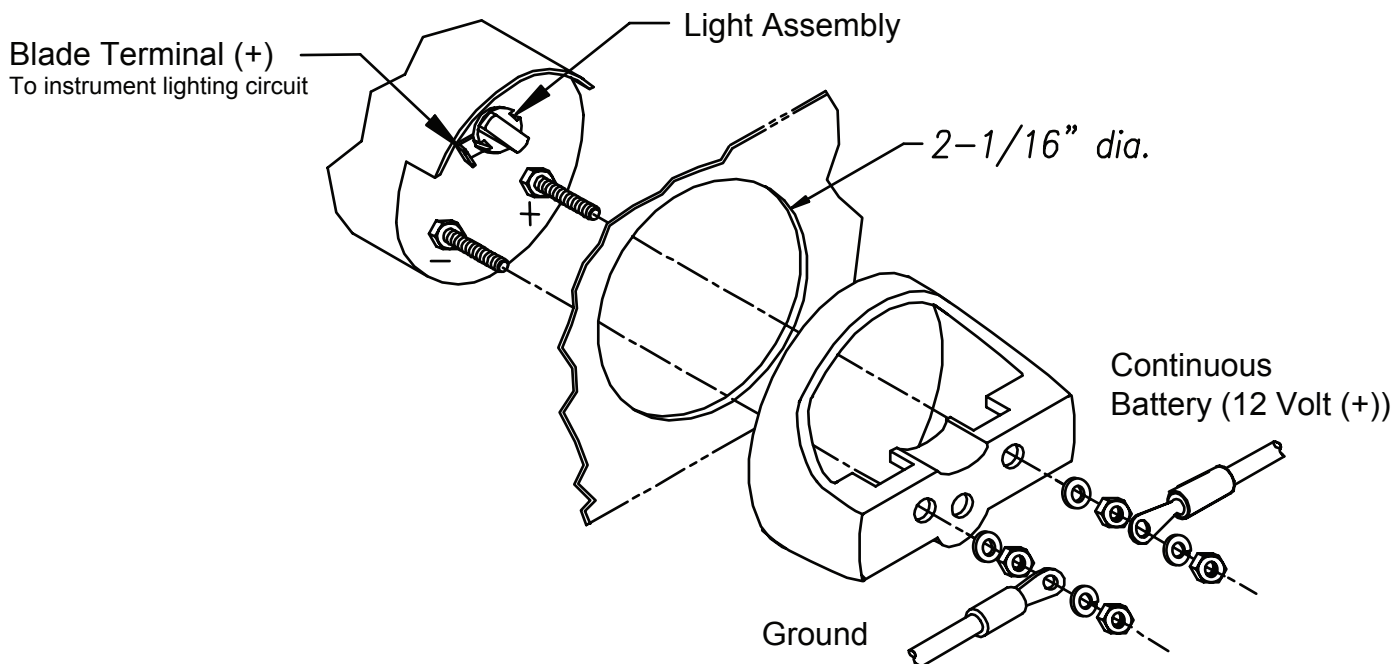

Reconnect Power

6. Reconnect the battery.