

DESCRIPTION: ELECTROMAGNETIC HORN

## MARINE HORN

### Main specifications and performances

Nominal voltage	12	Vdc
Voltage range	11,5-13,8	Vdc
Current consumption	4,5	A
Sound pressure level	112 (1m)	dB(A)
Frequency	405	Hz
Operating temperature	-30° to +80°	°C
Storage temperature	-30° to +80°	°C
Corrosion resistance	> 480 (salt spray test)	Hours
Operating relative humidity	30 to 80	%
Durability (1 sec ON, 4 sec OFF)	>50 000	Cycles
Continuous blowing	> 3	min
Electrical insulation	1000	Vdc
Vibration (30 min, 3 axis)	1	g
Weight	220	gr
Main materials	Steel, ABS	
Main applications		

### Dimensions (mm)

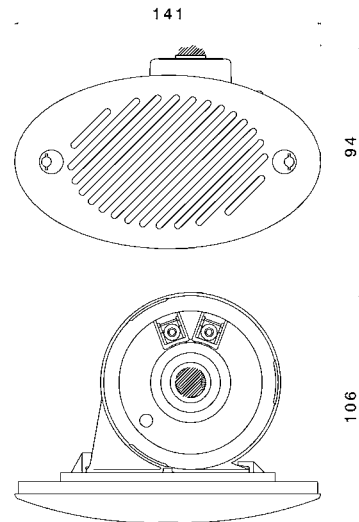

### Available Electrical Connection

Two Terminals 6,3x0,8 mm / 2 Spine 6,3x0,8 mm

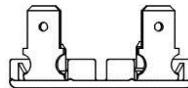

### Other specifications

**Mechanical connection:** flat and rigid surface facing the grill edge

**Horn's Protection:** choose an installation area protected from direct water and mud splash

**Packaging:** color box 83x 126 x h192 mm

**Master carton:** 9 pieces

### Conformity to Standards of

PRODUCT	✓	REG.10 ECE
MANUFACTURING	✓	ISO/TS 16949
	✓	ISO 9001
	✓	ISO 14001

### Packaging



### Product

BLACK (Ref.920314)  
(Ref. 5190411)



PANAMA  
(Ref. 5190111)



WHITE  
(Ref. 5190211)



STEEL  
(Ref. 5190511)

