

### INSTALLATION & SERVICE INFORMATION FOR MODELS 2840-000 & 2840-010 115 VOLTS AC AND MODEL 2840-210 230 VOLTS AC

#### PRODUCT DATA

<b>Pump Design</b> .....	Quad Diaphragm	
<b>Motor</b> .....	Permanent Magnet .....	TENV
<b>Wetted Parts</b> .....	Diaphragm Material .....	Santoprene
	Check Valve Material .....	EPDM
	Housing Material .....	Polypropylene
<b>Accumulator Tank</b> .....	Diaphragm Material .....	Butyl
	Liner Material .....	Polypropylene
<b>Ports</b> .....	3/4" HB Inlet & 1/2" HB/Qest Outlet	
<b>Net Weight</b> .....	8.8 Pounds (4 kgs)	

#### PERFORMANCE SPECIFICATIONS

##### PUMP

<b>Motor</b> .....	Max Amp Draw .....	1.5 @ 115 VAC
		0.75 @ 230 VAC
	Cycle .....	50/60 Hertz
<b>Liquid Temperature</b> .....	Min. ....	45°F (7°C)
	Max. ....	140°F (60°C)
<b>Priming</b> .....	Dry .....	5 ft. (1.5 M)
	Wet .....	15 ft. (4.6 M)
<b>Flow Rate</b> .....	Max .....	3.5/4.5 GPM @ 0 PSI (0.0 bar)
<b>Pressure Switch</b> .....	Off .....	45 PSI (3.1 bar)
	On .....	30 PSI (2.1 bar)

##### TANK

<b>Total Volume</b> .....	1.1 gal. (4.1 lt.)
<b>Operating Pressure</b> .....	Gal (0.8 lt.)
<b>Air Pressure Setting</b> .....	25 PSI (1.7 bar)

#### STANDARD MODEL NUMBERING SYSTEM

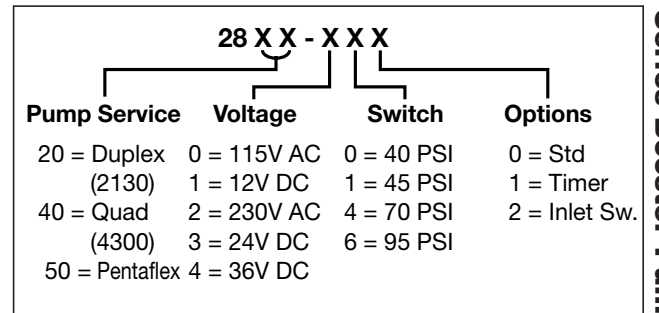

The standard model numbering system is used for models up to -500. Numbers -500 and over are used for variations from standard assemblies such as special pump or tank specifications. Consult the factory for special models to meet specific requirements.

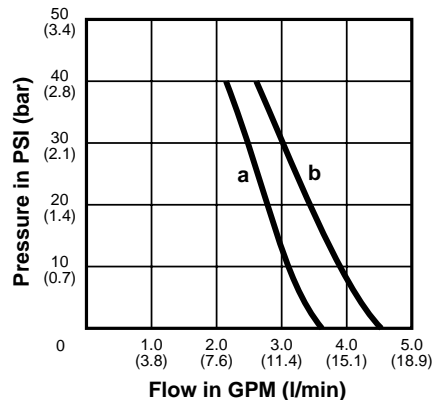

**a:**  
Model 2840-010  
Model 2840-210

**b:**  
Model 2840-000

#### DIMENSIONAL DRAWING

Inches (millimeters)

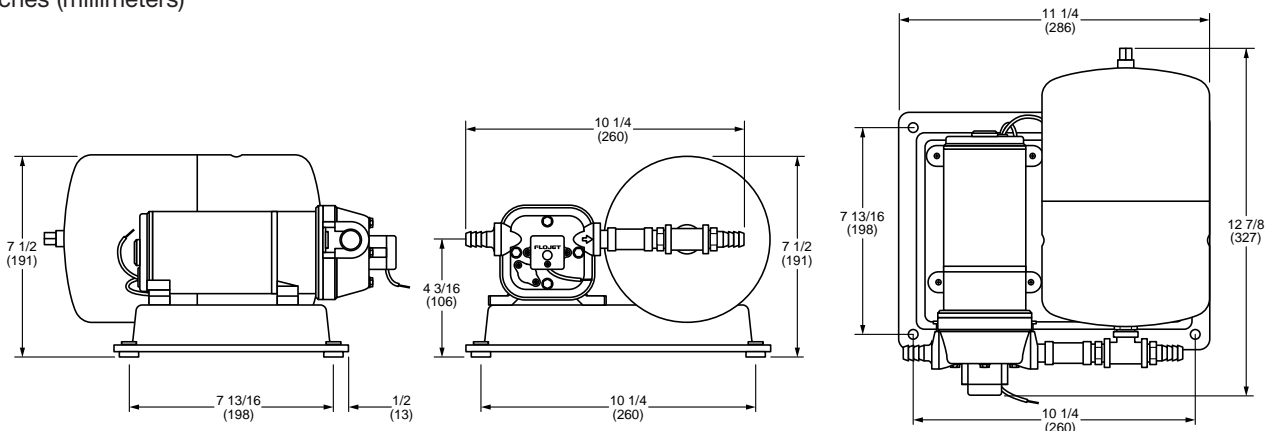

## GENERAL SAFETY INFORMATION

Protect yourself and others by observing all safety information. Shut off power and drain pressure from system prior to service.

## DESCRIPTION

The FLOJET 2840 series Booster Pump Systems are designed to provide a constant water pressure of 25 to 45 psi (1.7 - 3.1 bar) and maximum flow of 3.5 or 4.5 GPM at 10 psi (0.7 bar). The pump is fully automatic with a built-in switch and check valve to maintain system pressure and will supply smooth water flow from a trickle to full flow. Typical uses are; Commercial Ice Machines, Pure Water Dispensing, Water Purifiers, Small Domestic and Commercial Appliances where the water supply pressure is very low or fluctuates widely.

## OPERATION

**IMPORTANT** - For correct operation, the tank must be properly pressurized on the air side **before** the pump is started. Follow instructions on the tank label and check air pressure after filling and before starting the pump. The air valve is a standard tire valve. Compressed air hose or hand pump may be used to pressurize. Pressure can be reduced by pressing the center pin in the valve.

Make sure pump inlet connection is securely connected to the water supply and no inlet valves are open. Open all valves or taps on outlet side to purge air from the system. Turn power on to the pump, pump will start up. Allow system to pump for a minute or until all the air has been purged from the system. Close all valves in the system, the pump will pressurize the tank, shut off and operate automatically to maintain pressure in the system.

To completely fill the pressure tank for maximum volume, shut off power to pump and open faucet (or valve) closest to tank. Trapped air will be expelled. Turn on power to pump, and close faucet when water is free of air.

## WINTERIZING TIP

When units are exposed to freezing conditions.

1. Open discharge valve (Faucet nearest to the Booster System).
2. Open inlet side to pump (Remove inlet hose to the Booster System).
3. Run Pump for approximately 2 minutes, (Dry) or until system is out of fluid.
4. Leave discharge. value open and inlet hose removed until next usage.



**WARNING**



**DO NOT USE PUMP IN A FLAMMABLE ENVIRONMENT. DO NOT USE TO PUMP FLAMMABLE OR EXPLOSIVE FLUIDS SUCH AS GASOLINE, FUEL OIL, KEROSENE, ETC.**

## MOUNTING

The FLOJET 2840 Series Water Pressure System should be mounted in a dry and adequately ventilated area.

Select a location where the plumbing is as direct as possible and the inlet strainer is visible and accessible for cleaning.

The unit can be floor or wall mounted. If wall mounted, the Pump head should be down or lower than the motor.

Fasten base securely with the four rubber mounting feet assembled to base as shown below.

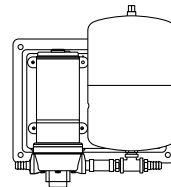

Vertical

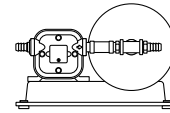

Horizontal

## PLUMBING

Fasten strainer in a visible and accessible location for future cleaning. Use 3/4" ID hose between pump inlet & strainer. Connect strainer inlet to water supply line and clamp all hose connections securely to avoid air leaks. **IMPORTANT** - if water supply line has pressure fluctuations that may exceed 30 psi (2.1 bar) - use a pressure regulator to limit inlet pressure to 30 psi (2.1 bar) maximum.

Regulator may be installed at any convenient location between water supply and inlet strainer.

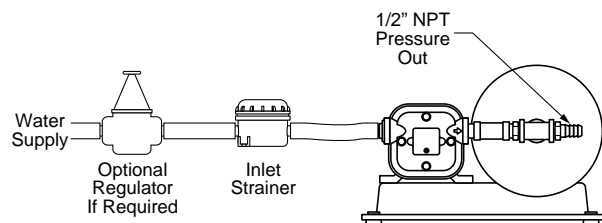

## ELECTRICAL



**WARNING**



### RISK OF AN ELECTRICAL SHOCK!

When wiring an electrically driven pump, follow all electrical and safety codes, as well as the most recent National Electrical Code (NEC) and the Occupational Safety and Health Act (OSHA).

### RISK OF PRODUCT DAMAGE!

Make certain the power source conforms to the pump voltage. Be sure all power is disconnected before installation or removal.

Use the maximum recommended fuse for pump protection. Recommended fuse amp rating is located on pump label. Failure to provide correct overload device may result in motor failure.

For 115V AC plug AC cord into a conventional 115V AC outlet.

**! WARNING: DISCONNECT POWER TO PUMP AND OPEN VALVE TO RELIEVE WATER PRESSURE PRIOR TO SERVICING PUMP !**

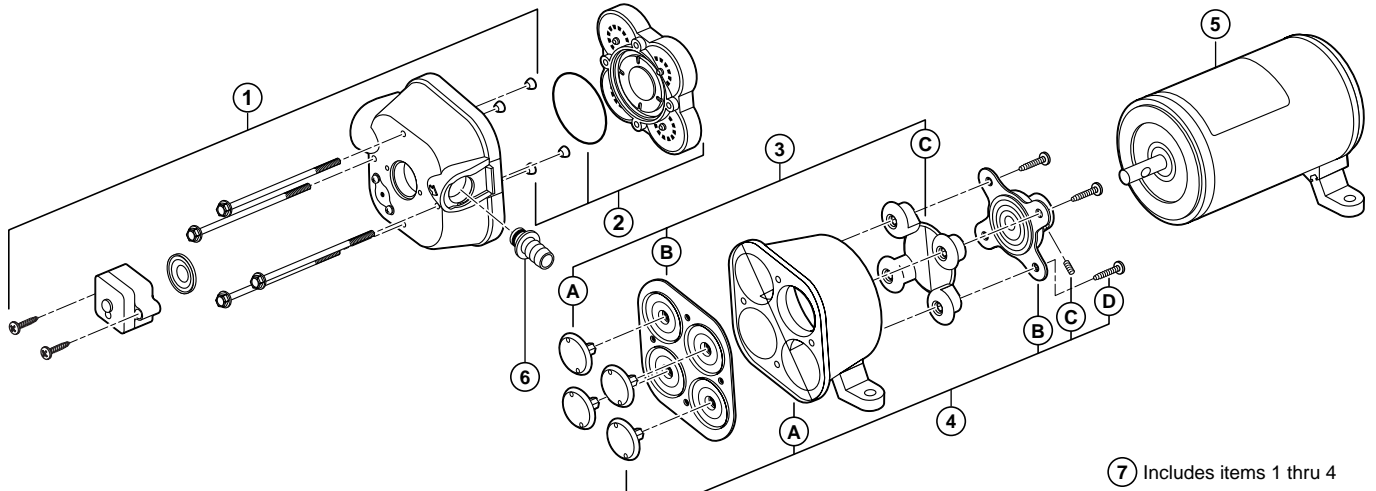

⑦ Includes items 1 thru 4

Key	Part No.	Description	Qty
1	20404-003	Upper Housing Assy Kit	1
2	20407-030	Check Valve Kit - EPDM w/O-Ring & Ferrules	1
3	20403-040	Diaphragm Kit, Santo w/Pistons & Screws	1
4	20419-00	Lower Housing 3.5 GPM	1
	20419-002	Lower Housing 4.5 GPM	1
5	02029-091A	Motor 115 Volt AC	1
	02039-087A	Motor 230 Volt AC	1
6	20381-022	Port Kit - (set of 2) EPDM, 3/4" Barb, 90° & EPDM, 5/8" Barb, Straight	1
			1
7	20406-000A	Pump Head Assy. 3.5 GPM	1
7	20406-002A	Pump Head Assy. 4.5 GPM	1

Key	Part No.	Description	Qty
8	20408-000	Port Clips (Set of 2)	1
9	02096-540	Pressure Switch - 40 PSI Off Sealed	1
**	04325-143A	Complete MPU 115 Volt - 3.5 GPM	1
**	04325-242A	Complete MPU 230 Volt - 3.5 GPM	1
**	04325-043C	Complete MPU 115 Volt - 4.5 GPM	1
**	01740-002	Strainer	1
**	20799-000A	Accumulator Tank	1
**	20796-000A	Base	1

\*\*Not Shown in Diagram

**DISASSEMBLE**

**Pressure Switch (9)**

1. Disconnect power to pump and open a faucet or valve to relieve system pressure.
2. Remove the two visible Pressure Switch Screws located on each side of the Pressure Switch (9). DO NOT ADJUST ALLEN HEAD SCREW IN CENTER OF SWITCH.

**Upper Housing (1)**

3. Loosen but DO NOT remove the four Pump Head Screws and carefully remove Upper Housing Assembly (1).
4. Slide Port Clip (8) back and unplug from Tank Plumbing.
6. Remove Check Valve (2) and inspect for debris.

**Check Valve Assembly (2)** Follow Steps 1, 3 & 4

6. Inspect Check Valve (2) and O-Ring

**Lower Housing (4)** Follow Step 1

7. Remove pump from both Base and Tank Plumbing.
8. Remove Rubber Feet by pulling out and sliding to the rear and follow step 3.
9. Rotate Lower Housing (4), so access Rubber Grommet foot notch is aligned with Cam Bearing Set Screw (4-C), loosen set screw with a 1/8" Allen Wrench and slide pump head off motor shaft.

**Diaphragm (3-B)**

10. Loosen four cam piston screws with Phillips head screw driver and pull apart cam (4-B) from Inner Pistons (3-A). (Both pistons (3-A & C) should be replaced when a new Diaphragm (3-B) is installed.)

**Motor (5)** Follow Steps 1, 7, 8 & 9

**REASSEMBLE**

**Diaphragm (3-B)**

1. Insert Outer Pistons (3-C) into Lower Housing (4-A) by bending pistons at center fold.
2. Placing the Diaphragm (3-B) (flatter side of Diaphragm facing the motor) on the Lower Housing (4-A). Press each Inner Piston (3-A) through the Diaphragm and Lower Housing (4-A) into Outer Piston (3-C). Hex stem of Inner Pistons (3-A) must be aligned into hex holes in Outer Pistons (3-C). Tighten cam piston screws partially, center piston in diaphragm, and tighten screws securely (18 in. lbs. torque). Also, the Outer Pistons (3-C) must be aligned with alignment slots on Cam Assembly (4-B) making sure screw holes align in cam assembly, otherwise diaphragm will leak.

**Cam Bearing (4-B)**

3. Place Cam Bearing (4-B) over Inner Pistons (3-C) and tighten down with four Phillips Head Screws. (18 in. lbs. torque)

**Lower Housing (4) to Motor (6)**

- Coat motor shaft with grease prior to installing Cam Bearing (4-B).
4. When installing the Lower Housing (4), rotate mounting foot notch to align with Cam Bearing Set Screw (4-C).
6. Attach Cam Bearing (4-B) to motor shaft indentation with Cam Bearing Set Screw (4-C). (35 in. lbs. torque)
6. Reinsert Rubber Feet.

**Check Valve (2)**

7. Place Ferrules (Rubber Cones) in the Upper Housing (1) coned side first.
8. Properly seat O-Ring in Check Valve (2) and insert Check Valve (2) into the Upper Housing (1).

**Upper Housing (1)**

9. Place Upper Housing (1) on top of the Lower Housing (4-A) and tighten Hex Bolts (30 in. lbs. torque) through the Upper Housing (1) to the Motor.

## TROUBLESHOOTING CHART

Symptom	Possible Cause(s)	Corrective Action
Pump will not prime or retain prime after operating	<ol style="list-style-type: none"> <li>1. Air leak in suction line</li> <li>2. Defective check valve</li> <li>3. Upper housing leaking</li> <li>4. Suction lift too high</li> <li>5. Debris in check valve(s)</li> </ol>	<ol style="list-style-type: none"> <li>1. Repair or replace</li> <li>2. Replace</li> <li>3. Tighten bolts</li> <li>4. Lower pump</li> <li>5. Clean check valve(s)</li> </ol>
Pump runs but no fluid	<ol style="list-style-type: none"> <li>1. Faulty suction piping</li> <li>2. Defective check valve</li> <li>3. Suction lift too high</li> <li>4., Clogged inlet</li> <li>5. Inlet line valve closed</li> </ol>	<ol style="list-style-type: none"> <li>1. Repair or replace</li> <li>2. Replace</li> <li>3. Lower pump</li> <li>4. Clean or replace</li> <li>5. Open valve</li> </ol>
Motor runs too hot	<ol style="list-style-type: none"> <li>1. Voltage incorrect</li> <li>2. Insufficient ventilation for motor</li> </ol>	<ol style="list-style-type: none"> <li>1. Check voltage</li> <li>2. Insure proper ventilation</li> </ol>
Flow rate is low	<ol style="list-style-type: none"> <li>1. Piping or hose is damaged</li> <li>2. Clogged check valve</li> <li>3. Worn check valve</li> <li>4. Voltage incorrect</li> </ol>	<ol style="list-style-type: none"> <li>1. Clean or replace</li> <li>2. Clear obstruction</li> <li>3. Replace</li> <li>4. Check voltage</li> </ol>
Pump leaks	<ol style="list-style-type: none"> <li>1. Upper housing loose</li> <li>2. Pistons loose</li> <li>3. Pump head loose on motor</li> <li>4. Switch loose</li> </ol>	<ol style="list-style-type: none"> <li>1. Tighten screws</li> <li>2. Tighten piston screws</li> <li>3. Tighten pump head screws</li> <li>4. Tighten switch</li> </ol>
Pump will not run	<ol style="list-style-type: none"> <li>1. No electricity</li> <li>2. Defective pressure switch</li> <li>3. Motor has open circuit</li> <li>4. Thermal protector has cut off</li> </ol>	<ol style="list-style-type: none"> <li>1. Check connections, fuse, breakers</li> <li>2. Replace switch</li> <li>3. Replace</li> <li>4. Allow motor to cool 15-30 min</li> </ol>

## CONVERSION TABLE

TO CONVERT	TO	MULTIPLY BY
Gallons, U.S.	Liters	3.785
Liters	Gallons, U.S.	0.264
Pounds/Sq. Inch	Bar	0.069
Bar	Pounds/Sq. Inch	14.5
Fahrenheit	Celsius	(°F-32) .556
Celsius	Fahrenheit	(°C X 1.8) + 32

## WARRANTY

FLOJET warrants this product to be free of defects in material and/or workmanship for a period of one year after purchase by the customer from FLOJET. During this one year warranty period, FLOJET will at its option, at no charge to the customer, repair or replace this product if found defective, with a new or reconditioned product, but not to include costs of removal or installation. No product will be accepted for return without a return material authorization number. All return goods must be shipped with transportation charges prepaid. This is only a summary of our Limited Warranty. For a copy of our complete warranty, please request Form No. 100-101.

**Flojet**

---