

FULTON®



XLT 7.0, XLT 10.0 Marine Winch Instruction Manual

WAVES OF **INNOVATION**

CE

Read, Understand, Follow and Save These Instructions

- Read, understand and follow all of these instructions and warnings before installing and using this product.
- Install and use this product only as specified in these instructions.
- Improper installation or use of this product may result in property damage, serious injury, and/or death.
- Never allow installation or use of this product by anyone without providing them with these instructions.
- You must read, understand and follow all instructions and warnings for any product(s) to which this product is used in conjunction with or installed.
- Save these instructions with the product for use as a reference for any future installation and use of the product.

Throughout this manual **WARNING, CAUTION, NOTICE** and the **SAFETY ALERT SYMBOL** will be used.



The safety alert symbol alerts you to potential physical injury hazards. Obey all safety messages that follow this symbol to avoid possible injury or death.



WARNING

WARNING indicates a hazardous situation that, if not avoided, could result in death or serious injury.



CAUTION

CAUTION indicates a hazardous situation that, if not avoided could result in minor or moderate injury.

NOTICE

NOTICE indicates a hazardous situation that, if not avoided, could result in property damage

Table Of Contents

Safety	Page
Tools Required	2
Important Safety Messages	3
Know Your Winch	4
Features and Ratings	5
Instructions	
Installation Instructions	5
Operation Instructions	10
Maintenance	12
Checklist	13
How To Order	13

TOOLS REQUIRED



Adjustable Wrench

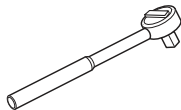

3/8" Ratchet



9/16" Socket

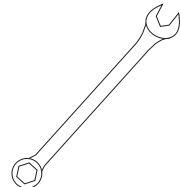

9/16" Combination Wrench

Important Safety Messages

Before First Operation

- Purchaser/owner must ensure that product is installed according to these instructions. Purchaser/owner must not alter or modify product.



- Understand your winch and its instructions.
- Never exceed maximum rated capacity. Refer to stamped markings or decals on product to obtain rated capacity. If uncertain, contact Horizon Global at 1-800-632-3209 or fultonperformance.com.
- The winch is rated at the first layer strap on the drum for intermittent-periodic duty.

Are you ready to pull?

- NEVER operate this winch when under the influence of drugs, alcohol or medication.



- ALWAYS remove jewelry and wear eye protection.



- Use leather gloves when handling the strap hook.
- NEVER let winch strap slip through your hands.
- NEVER touch a winch strap or hook when someone else is at the controls.
- NEVER touch winch strap or hook while under tension or under load.
- ALWAYS stand clear of winch strap and load and keep others away while winching.



- Do not use the winch as a lifting device or a hoist for vertical lift.
- Operator and bystanders should never position any part of body under any portion of this product or the load being supported.
- Do not allow children to play on or around this product or the load being supported.



- Keep clear of winch, strap, hook, and fairlead while operating.



- The winch is not to be used to lift, support or otherwise transport humans.



- ALWAYS be aware of possible hot surfaces at winch motor or drum during or after winch use.
- ALWAYS ensure the operator and bystanders are aware of the stability of the vehicle and/or load.

Is your winch ready to pull?

- ALWAYS inspect winch strap, hook, and slings before operating winch. Frayed, kinked or damaged winch strap must be replaced immediately. Damaged components must be replaced before operation.
- Periodically check mounting hardware for proper torque and tighten if necessary.
- ALWAYS remove any element or obstacle that may interfere with safe operation of the winch.
- ALWAYS be certain winch stand will withstand the load.
- Strap can break without warning. Always keep a safe distance from the winch and strap while under a load.
- NEVER wrap winch strap back onto itself.



- ALWAYS ensure hook latch is closed and supporting load.



- NEVER apply load to hook tip or latch. Apply load only to the center of hook.
- NEVER use a hook whose throat opening has increased, or whose tip is bent or twisted.
- ALWAYS use a hook with a latch.

- NEVER use winch rope or strap for towing.
- NEVER use excessive effort to free spool winch Strap.
- ALWAYS take time to use appropriate rigging techniques for a winch pull.

During the pull

- NEVER exceed winch or winch strap rated capacity. Double line using a snatch block to reduce winch load.
- NEVER use the winch to secure the load.
- NEVER use the winch to secure a boat to a trailer.
- Always secure the boat with a safety chain or tie down, not the winch.
- Do not shock load the winch.
- Never engage or disengage the clutch when the winch is under load or the drum is moving.
- Pull from an angle of less than 5 degrees to avoid the strap from piling onto one side of the drum and possibly do damage to the strap or winch. Re-spool your winch as required.
- ALWAYS avoid side pulls which can pile up winch rope or strap at one end of the drum. This can damage winch rope, strap or winch.
- ALWAYS ensure the clutch is fully engaged or disengaged.
- NEVER submerge winch in water.

After Use

- Wash with mild soap and water.

Know Your Winch

Figure 1 - Winch Components

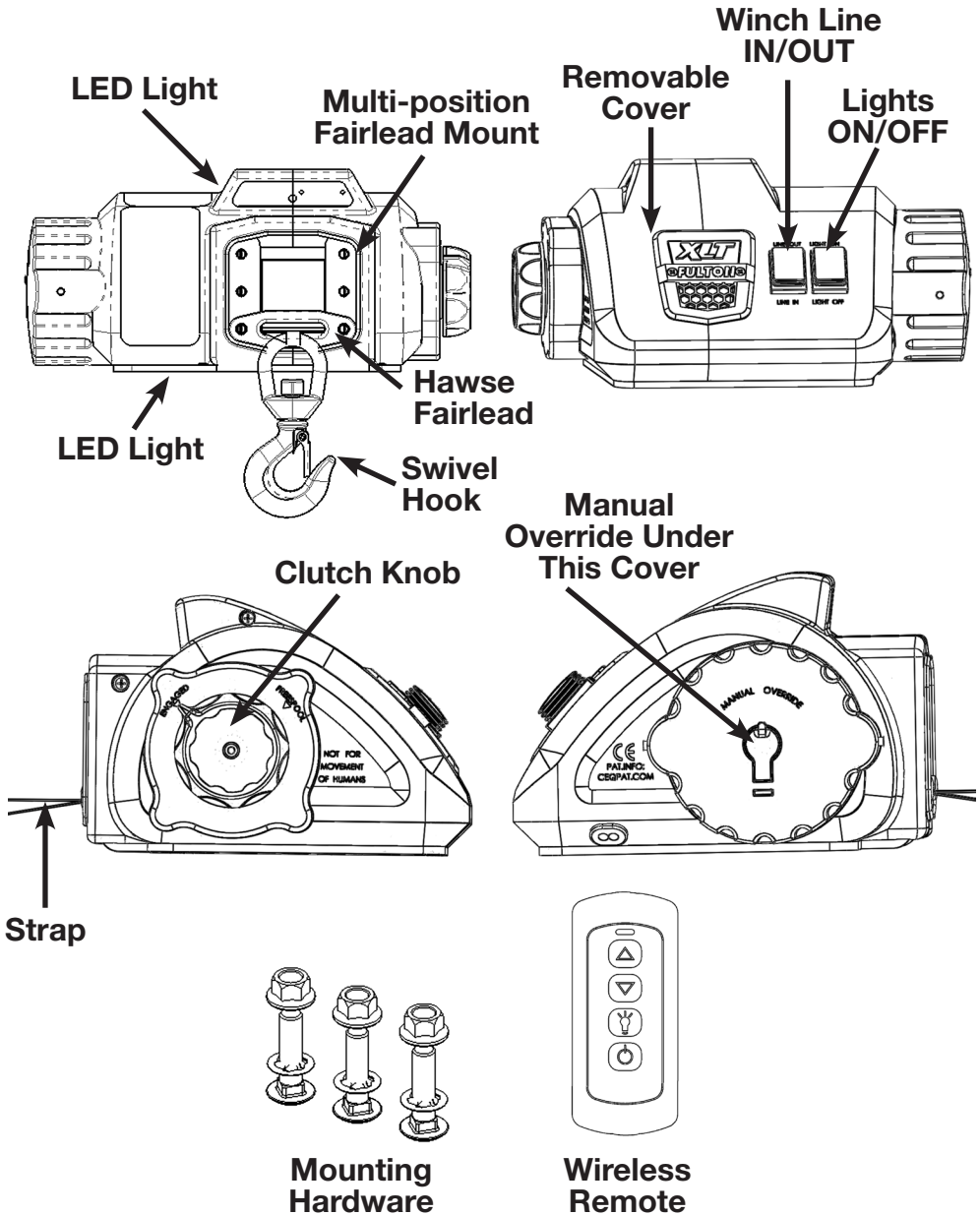

Features and Ratings

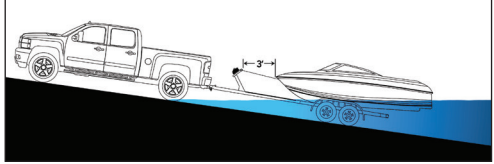
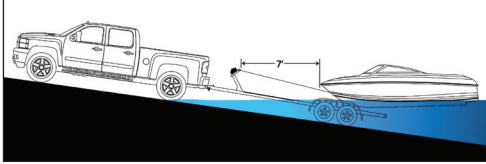

Amp draw and line speed varies according to the load, the trailer configuration, battery charge, the angle of the ramp, how submerged the trailer is and many other potential influences. As the boat gets closer to the bow stand, the strap will build up to a larger diameter on the drum reducing the capacity of the winch.

Table 1 - Winch Ratings / Specifications

XLT 7.0		XLT 10.0	
Max. Recommended Boat Weight	7,000 lbs.	Max. Recommended Boat Weight	10,000 lbs.
Max. Recommended Boat Length	20'	Max. Recommended Boat Length	26'
Wireless Remote Control	Yes	Wireless Remote Control	Yes
Light	Yes	Light	Yes
Power Source	12V	Power Source	12V
Max. Amp Draw	160 amp	Max. Amp Draw	200 amp
Strap	2" x 15'	Strap	2" x 15'
Brake	Mechanical	Brake	Mechanical
Clutch (free- spooling)	Turn Knob	Clutch (free- spooling)	Turn Knob
Controls	Remote / Switch on Winch	Controls	Remote / Switch on Winch

Installation Instructions

BEFORE INSTALLING AND USING YOUR POWERED WINCH, READ AND FOLLOW ALL MOUNTING INSTRUCTIONS AND SAFETY MESSAGES.

Mounting

⚠ WARNING

To prevent accidental activation of the winch and serious injury, complete the winch installation and attach the hook before installing the wiring.

1. Before Installation

1.1 Inspect Parts

- Instruction/Owners Manual
- Winch Assembly
- Clutch Knob
- Power Leads
- Wireless Remote
- Strap and Hook
- Hawse Fairlead
- Mounting Hardware

Installation Instructions

Mounting Hardware Requirements

Refer to Table 2 below for bolt quantity, sizes, and required torque. Mounting system will dictate bolt length.

WARNING

ALWAYS torque mounting bolts to the values specified for your winch in Table 2.

ALWAYS use grade 5 (class 8.8 metric).

NEVER weld mounting bolts.

ALWAYS choose the proper bolt length for your application.

ALWAYS confirm required bolt length to ensure proper thread engagement. A minimum of two whole threads should protrude from the nut.

Table 2 - Mounting Torque Requirements

Powered Winches	XLT 7.0	XLT 10.0
Winch Mounting Bolt Size	Three 3/8-16 grade 5 carriage bolts Three 3/8" retaining washers Three 3/8" NY-Lock nuts	Three 3/8-16 grade 5 carriage bolts Three 3/8" retaining washers Three 3/8" NY-Lock nuts
Winch Mounting Bolt Torque	28-30 ft./lbs.	28-30 ft./lbs.

1.2 Select Mount Location

WARNING

ALWAYS choose a mounting location that is sufficiently strong to withstand the maximum pulling capacity of your winch.

The winch should be positioned so that the strap exits the winch horizontal to the bow eye when the boat is fully loaded onto the trailer.

The fairlead should be a minimum of 6" away from the from the bow eye when the boat is fully loaded onto the trailer. See Figure 2.

1.2.1 Winch Mounting Considerations

Your mounting surface must be equal to or greater than the mounting surface of the winch frame. See Figure 3. Three sets of Grade 5 3/8" hardware are required to mount this winch.

Figure 2 - Mount Location

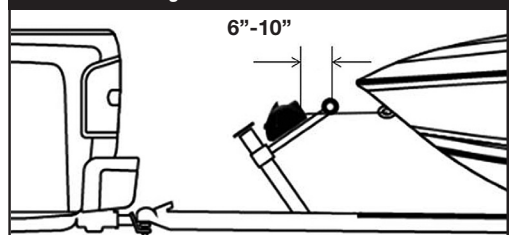
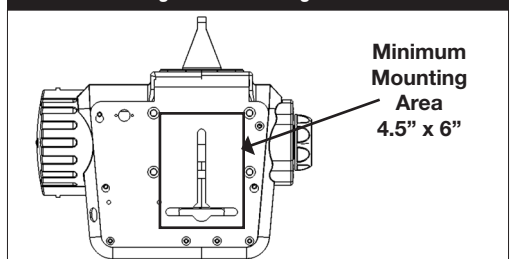

Figure 3 - Mounting Surface



Installation Instructions

1.2.2 Easy Install System

Place the three 3/8" Grade five carriage bolts, with the retaining washers in place, into the "T" slot on the base of the winch.

Place winch over the mounting plate and insert the bolts through the mounting holes in the mounting surface of your winch stand. Secure the flanged lock nuts to the mounting bolts. Torque to 28-30 ft.-lbs. Be sure that a minimum of two complete threads show after tightening the flange lock nuts. See Figure 4.

Figure 4 - Mounting

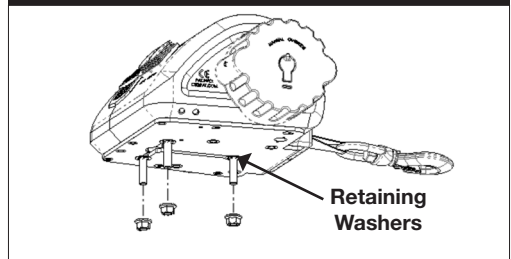

1.2.3 Mounting Configurations

Wind the strap from the bottom of the drum. See Figure 5.

Figure 5 - Under Wound

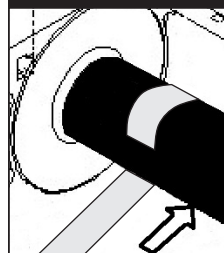

Under-wind Only

⚠ WARNING

Failure to adequately align, support, or attach the winch to a suitable mounting base may result in property damage, personal injury and/or death.

1.3 Hawse Fairlead

The use of a Hawse Fairlead can reduce the contacting friction with the strap. An aluminum hawse fairlead is recommended because it has no sharp edges and resists wear damage more effectively than a roller fairlead. The fairlead does not ensure the strap will wind onto the drum in an orderly manner.

1.4 Wiring

1.4.1 Install the Wiring

⚠ WARNING

BEFORE installing the winch, make sure all electrical parts are corrosion free.

NEVER lean over battery while making connections.

NEVER route electrical cables over battery terminals.

Run the charging system during winching operations to keep battery charged.

NEVER route electrical cables across sharp edges.



NEVER route electrical cables near parts that get hot.

NEVER route electrical cables through or near moving parts.



AVOID pinch and wear/abrasion points when installing all electrical cables.

ALWAYS insulate and protect all exposed wiring and electrical terminals.

Installation Instructions

1.4.2 Battery Recommendations & Lead Size

A fully charged battery and good connections are essential for the proper operation of your winch. The minimum requirement for the battery is 650 cold cranking amps. Use table 3 to determine the minimum battery lead diameter, otherwise a considerable voltage drop will occur.

Table 3 - Wire Length / Gauge

WIRE LENGTH	5'	10'	15'	20'	25'
WINCH MODEL	W I R E G A U G E				
XLT 7.0	10	8	6	4	4
XLT 10.0	10	6	4	4	2

1.4.3 Battery Cable Routing

WARNING

ALWAYS route battery cables along a path that allows the cables to be secured with zip ties. Loose or unsecured power cables can cause serious injury or death.

Figure 6 - Wiring Option 1

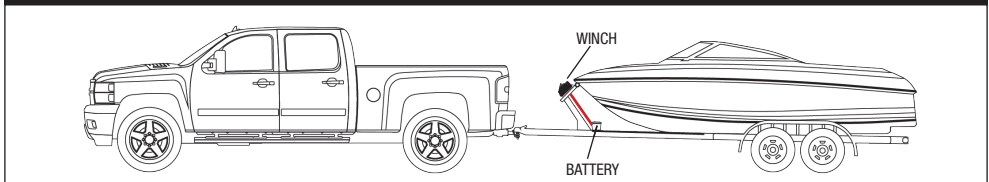

Option 1:

When using option one; Secure your battery to the trailer. Connect the positive and negative leads directly to the battery. This option will require the battery to be charged when not in use.

Figure 7 - Wiring Option 2

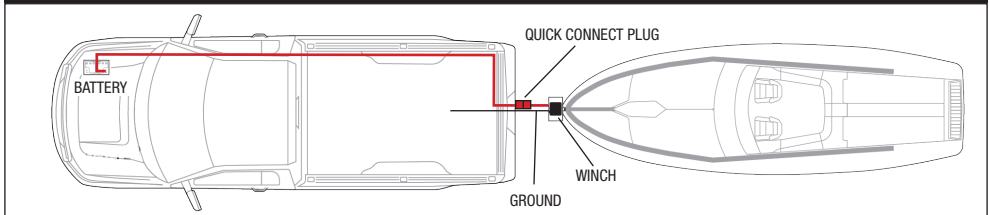

Option 2:

1. This option is ideal when a boat always uses the same tow vehicle.
2. Using Table 3 select the correct diameter wire for the length of wire used.
3. Plan the routing path.
4. Loosely secure power cables along path.
5. Confirm power cables are protected from sharp edges, heat and moving parts. Consider chassis flex and vibration which might damage cable.
6. Carefully inspect electrical cable routing. Zip tie and secure electrical cables. Zip ties should be snug, but not cutting into wire insulation. Use electrical tape, pieces of rubber hose or electrical conduit to protect electrical cables and wire harness where needed to avoid electrical cable insulation wear or abrasion.

Installation Instructions

7. Once your power lead is routed and securely fastened, attach the rear side of the power lead into a quick connect plug P/N 500607.
8. Use a short ground lead (the same diameter as the power lead) and connect it to the quick connect next to the power lead. Take the quick connect and mount it to the back of the tow vehicle.
9. Take the short ground lead and ground it to the vehicles frame.
10. Connect your second quick connect to the winch leads.
11. Connect the power lead to the tow vehicle's battery.

1.4.4 System Check

Upon completion of installation, check winch for proper operation. The voltage drop for the winch motor must not exceed 10% of the nominal voltage of 12V DC.

1.5 Know Your Wireless Remote

WARNING

Never lose sight of the winch while using the wireless remote.
Never touch the winch or jack while the remote is in someone else's hands.

1.5.1 Wireless Remote and Transmitter Specifications

1. Transmission range: 50 to 90 ft (15 to 27 m)
2. Operating temperature range: -20°C to +70°C
3. 2.4G wireless transmission technology.
4. The remote control uses one 12V MN2123 battery.

1.5.2 Wireless Remote Operation

Your wireless remote control device comes pre-programmed and ready to use. Your wireless remote has an auto shutdown feature. The remote control has four buttons:

1. Press and hold the bottom button to turn the wireless remote control and an indicator light ON or OFF.
2. The second button on the remote turns the winch lights ON or OFF.
3. The top two buttons power the winch line IN and OUT.

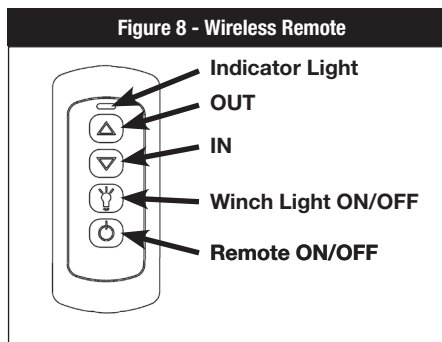

Installation Instructions

1.5.3 Indicator Light

1. When the remote is turned on it will search for a signal for 1 to 3 seconds. If a signal is found the blue light will stay on.
2. If the winch is not powered up or you are out of range, the blue light will blink regularly.

1.5.4 Pairing Wireless Remote

Pairing your wireless remote (transmitter) to the receiver in the winch. Each remote can only be paired once.

1. Be sure that you have power to the winch.
2. Turn on the remote.
3. Simultaneously press the IN/OUT buttons.
4. The indicator light will blink for two to five seconds and will stop blinking and show a steady blue light. End of coding.

Table 4 - Remote Indicator Light Flash Descriptions

Number	Flash Mode	Reason	Solutions
1	A steady blue flash indicates that your remote control is not in radio contact with the winch.	Signal disconnected or out of range.	Use the controls on the winch.
2	A steady double blue flash indicates that the battery in the wireless remote control is running low.	The battery in the wireless remote control is running low.	Replace the battery in the wireless remote control.
3	The blue indicator light is on.	The system is working properly.	The winch is ready for use.

Operation Instructions

2.1 Spooling in Under Load

WARNING

NEVER exceed winch's rated line pull. Power-in the winch strap evenly and tightly on the drum. **NEVER** touch winch strap or hook while someone else is at the control switch or during winching operation.

Do not shock load the winch when spooling. Avoid shock loads when spooling by pulsing the control switch to take up winch strap slack. Shock loads can momentarily far exceed the winch and strap ratings.

NOTICE

DO NOT power the hook into the fairlead. This could cause damage to the fairlead.

2.2 Overloading / Overheating

This winch is rated for intermittent duty. When the motor approaches stall speed, very rapid heat buildup occurs which may cause motor damage.

Operation Instructions

2.3 Safe Working Conditions

⚠ WARNING

The operator should ALWAYS operate the winch from a safe position when pulling a load. The safe areas are: Perpendicular to the winch strap.

The safe position will help prevent the strap from striking the operator if the strap fails when under load.

⚠ WARNING

NEVER work around the winch strap while it is under load.

NEVER step over a winch strap while it is under load.

ALWAYS use caution when working with electricity and remember to verify that no exposed electrical connections exist before energizing your winch circuit.

2.4 Clutch Operation

⚠ WARNING

NEVER engage or disengage clutch if winch is under load, winch strap is in tension or drum is moving.

To prevent damage, **ALWAYS** fully engage or fully disengage the clutch knob.

The clutch lever, located on the winch housing opposite the motor, controls the clutch position. When the clutch is engaged, the gear train is coupled to the winch drum and power can be transferred from the winch motor.

⚠ CAUTION

NEVER engage the clutch while the drum is rotating.

2.4.1 Disengage Clutch For Free-Spooling

Turn the clutch knob to the free-spool position. Strap can now free-spool off the drum. Figure 10.

2.4.2 Engage Clutch For Winching

Turn the clutch knob to the engaged position. Never engage the clutch while the drum is rotating. Figure 11.

⚠ WARNING

Do not use the winch as a lifting device or a hoist for vertical lifting.

⚠ CAUTION

The “Power-Out” function should be used for relieving tension on the strap, not for extended distances.

The “power out” function drives the winch motor against the brake which is similar to driving your vehicle with the parking brake engaged. Do not use the Power-Out function for lowering a load -- winches are not designed to be used as hoists. Use the free-spool function to pay out strap. If you power out over 25 feet, let the winch cool for 15 minutes.

Figure 10 - Disengage Clutch

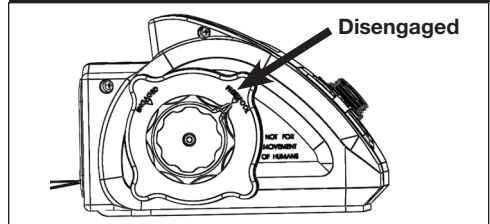
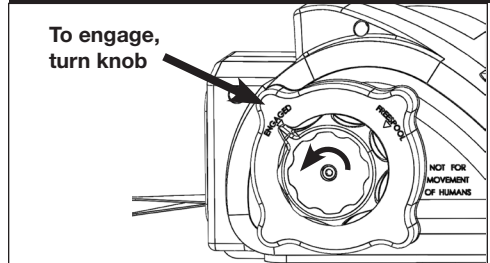

Figure 11 - Engage Clutch



Maintenance

3.1 Strap Replacement

1. Disengage the clutch knob.
2. Un-spool the entire strap.
3. Remove the clutch knob and side cover as shown.

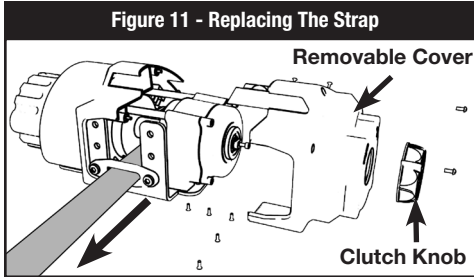

4. Remove the two bolts from the split collar.
5. Remove the split collar.

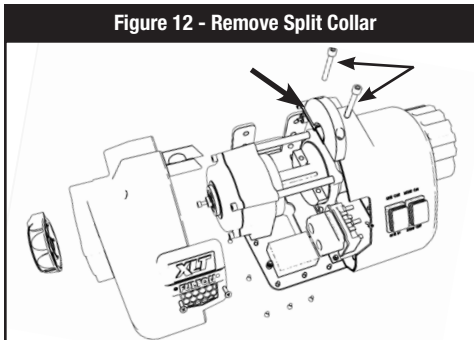

6. Remove the worn strap and the strap retaining pin.

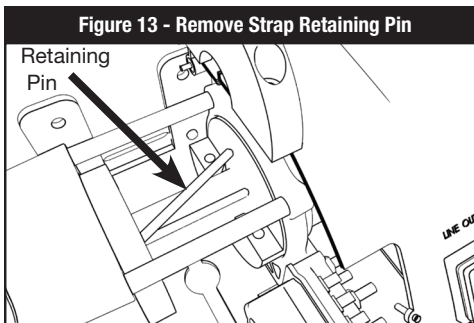

7. Insert the strap through the Hawse fairlead and insert the strap retaining pin through the strap loop.

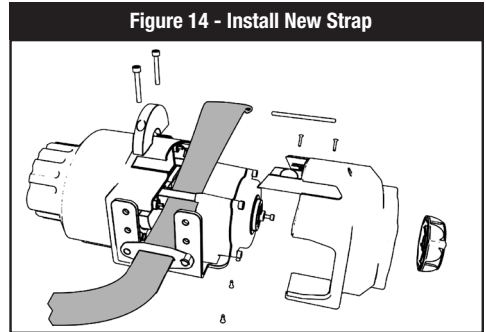

8. Insert the strap retaining pin and strap into the groove on the winch drum.
9. Replace the split ring collar and torque bolts to 24 ft.-lbs.

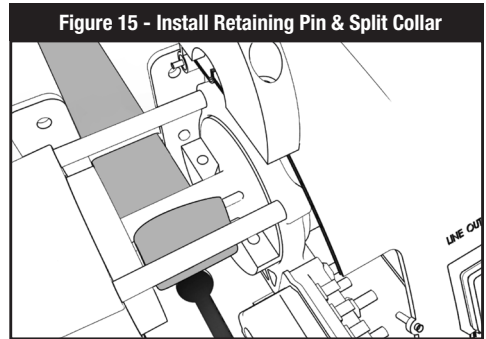

10. Replace the side cover.
11. Replace the clutch knob. Torque to 12 ft.-lbs.
12. Wind strap onto drum by pushing and holding the "LINE IN" button until the strap is spooled onto the drum. Keep tension on the strap while it is winding.

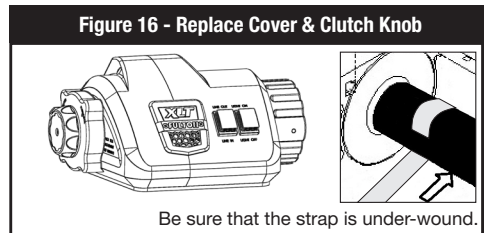

Maintenance

Table 5 - Checklist

	Before First Operation	After EVERY Use	Every 90 Days
Read, understand and follow the warnings and instructions in this manual.	X		
Check all fasteners and verify they are at the proper torque. Replace fasteners as needed.	X		X
Check wiring is correct and the connections are tight	X		X
Check there are no bare or exposed wires, terminals, or damage to the cables (chafing/cutting). Repair or replace wires as needed.	X		X
If damaged, discontinue use and replace strap immediately.	X	X	X
Keep winch, strap, and switch control free from contaminants. Use a clean rag or towel to remove any dirt and debris.		X	

3.2 Pairing Replacement Remote

The remote transmitter and receiver are paired and cannot be interchanged. If a wireless remote (transmitter) is lost, a new one can pair itself to an existing receiver. The pairing method is as follows:

1. Turn on the remote control while simultaneously pressing the IN/OUT buttons. The wireless remote will blink for 2 to 5 seconds and will change to a constant blue light. Your remote is now paired to your winch.
2. If the red light flashes the control system should be serviced.

3.3 Lubrication

All moving parts in the winch are permanently lubricated at the time of assembly. Under normal conditions factory lubrication will suffice. If re-lubrication of gear box is necessary after repair or disassembly use Shell EP2 or equivalent grease. Never lubricate the brake system.

WARNING

To prevent SERIOUS INJURY, DEATH and PROPERTY DAMAGE, you should read, understand and follow the warnings and instructions in this manual.