

OWNER'S GUIDE & INSTALLATION INSTRUCTIONS

Thru-Hull Mount

Multi-beam Sonar & Depth Transducer

with Temperature Sensor & High-Performance Fairing

Model SS542

WARNING

Installation of the anti-rotation bolt is mandatory!

The anti-rotation bolt holds the fairing firmly in place. Failure to install the anti-rotation bolt may result in the fairing rotating while the boat is underway. The effect may be violent movement and loss of steering. This could result in serious injury or death to passengers and/or damage to the boat or other property.

Follow the precautions below for optimal product performance and to reduce the risk of property damage, personal injury, and/or death.

WARNING: The transducer must be installed with a High-Performance Fairing.

WARNING: When installing the High-Performance Fairing carefully follow these installation instructions.

WARNING: Always wear safety glasses, a dust mask, and ear protection when installing.

WARNING: The fairing must be installed parallel to the keel to ensure proper boat handling.

WARNING: Do not install a fairing that has been mis-cut. Replace it.

- Cutting the fairing at an angle greater than the maximum allowed will cut into the transducer and/or bolt pocket, thus weakening the fairing.
- Do not allow any gap between the fairing and the hull that is greater than 3mm (1/8"). When the boat is underway, water will enter any gaps and push against the fairing with considerable force, possibly rotating it.

WARNING: Immediately check for leaks when the boat is placed in the water. Do not leave the boat unchecked for more than three hours. Even a small leak may allow considerable water to accumulate.

CAUTION: Stainless steel transducer in a metal hull— Use sleeving to isolate the stainless steel transducer and anti-rotation bolt from the metal hull. Failure to do so will cause electrolytic corrosion.

CAUTION: Never pull, carry, or hold the transducer by the cables as this may sever internal connections.

CAUTION: Never strike the transducer.

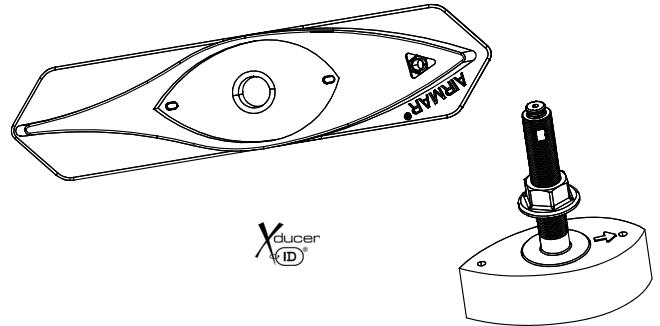

CAUTION: Do not over-tighten the hull nut and the nut on the anti-rotation bolt, crushing the fairing and/or hull.

CAUTION: The transducer and the yellow triangular plug must be flush with the fairing for smooth water flow under the transducer.

CAUTION: Never use solvents. Cleaner, fuel, sealant, paint, and other products may contain solvents that can damage plastic parts, especially the transducer's face.

IMPORTANT: Read the instructions completely before proceeding with the installation. These instructions supersede any other instructions in your instrument manual if they differ.

Applications

- Stainless steel transducer compatible with all hull materials. *Recommended for aluminum hulls to prevent electrolytic corrosion provided the stainless steel transducer is isolated from the metal hull.*
- Maximum deadrise angle of 20°.

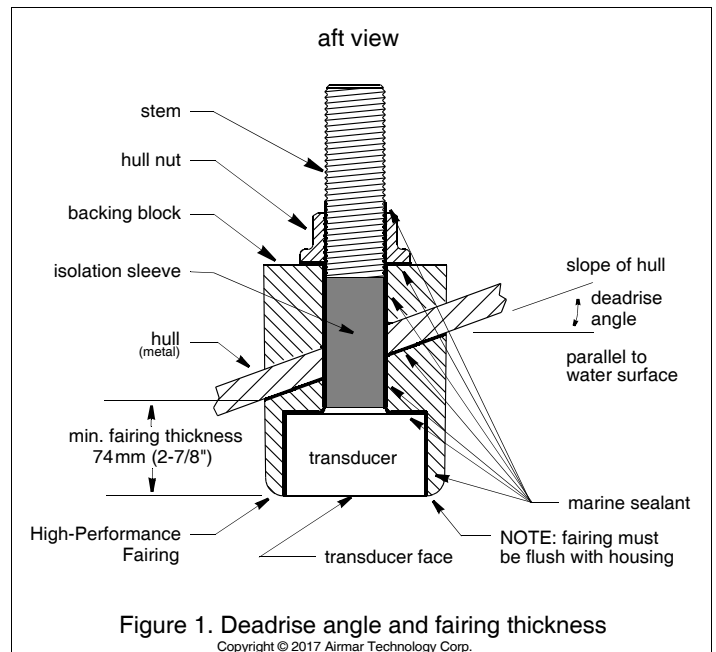
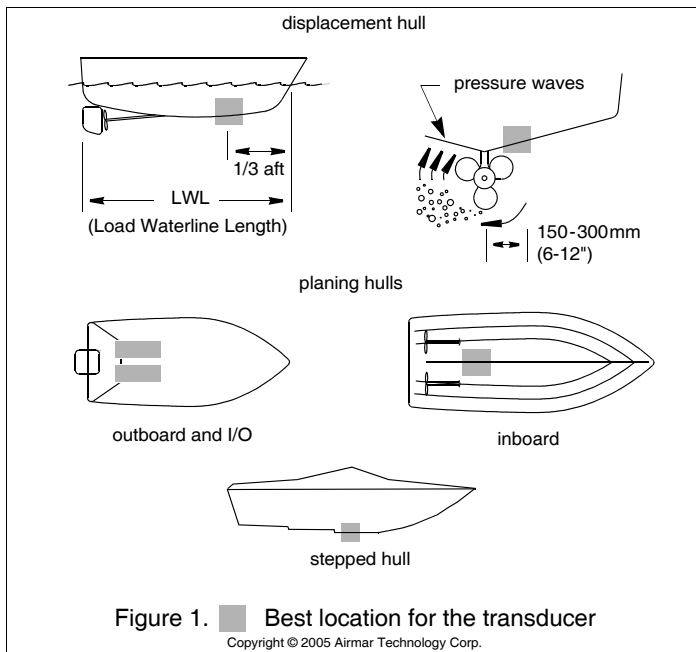

Identify Your Model

The model name is printed on the cable tag.

Tools & Materials

Safety glasses

Dust mask

Ear protection

Electric drill

Drill bits and hole saws

Pilot hole 3mm or 1/8"

Hull Material	Transducer Hole-Saw Size	Anti-rotation Bolt Hole Drill Bit Size
solid fiberglass or wood	33mm or 1-5/16"	14mm or 9/16"
metal	35mm or 1-3/8"	15mm or 9/16"

Angle finder

Band saw (sharp blade)

Rasp or power tool

Sandpaper

Mild household detergent or weak solvent (such as alcohol)

File (installation in a metal hull)

Marine sealant (suitable for below waterline)

Slip-joint pliers

Mallet

Grommets (some installations)

Cable ties

Water-based anti-fouling paint (**mandatory in salt water**)

Installation in a cored fiberglass hull (see page 5)

Cylinders, wax, tape, and casting epoxy.

Hole Saw for Transducer (outer skin)	Minimum Size Hole Saw for Transducer (inner cored hull)	Drill Bit for Anti-rotation Bolt (outer skin)	Minimum Size Drill Bit for Anti-rotation Bolt (inner cored hull)
33mm or 1-5/16"	50mm or 2"	14mm or 9/16"	30mm or 1-1/4"

Mounting Location

CAUTION: Do not mount in line with or near water intake or discharge openings or behind strakes, struts, fittings, or hull irregularities that will disturb the water flow.

- The water flowing under the hull must be smooth with a minimum of bubbles and turbulence (especially at high speeds).
- The transducer's face must be continuously immersed in water.
- The transducer beam must be unobstructed by the keel or propeller shaft(s).
- Choose a location away from interference caused by power and radiation sources such as: the propeller(s) and shaft(s), other machinery, other echosounders, and other cables. The lower the noise level, the higher the echosounder gain setting that can be used.
- Choose a location with a minimum deadrise angle.
- Choose an accessible spot inside the vessel with adequate space for the height of the stem and tightening the nut.

Boat Types (Figure 1)

- **Displacement hull powerboat**—Locate 1/3 of the way back along the LWL and 150–300mm (6–12") off the centerline. The starboard side of the hull where the propeller blades are moving downward is preferred.
- **Planing hull powerboat**—Mount well aft near the centerline and *well inboard of the first set of lifting strakes* to insure that it is in contact with the water at high speeds. The starboard side of the hull where the propeller blades are moving downward is preferred.
 - Outboard and I/O**—Mount just forward and to the side of the engine(s).
 - Inboard**—Mount well ahead of the propeller(s) and shaft(s).
 - Stepped hull**—Mount just ahead of the first step.
- **Boat capable of speeds above 25 kn (29MPH)**—Review transducer location and operating results of similar boats before proceeding.

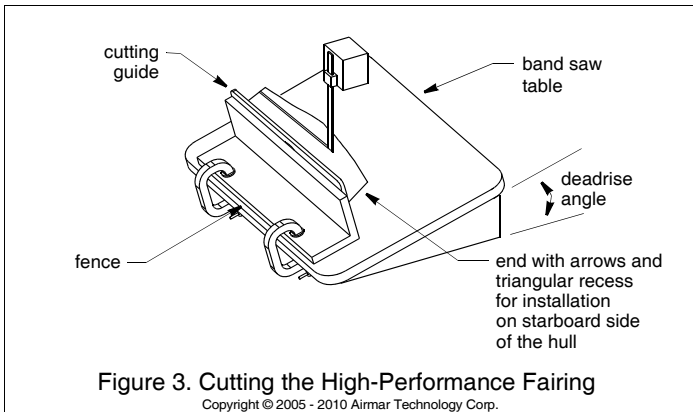

Figure 3. Cutting the High-Performance Fairing

Copyright © 2005 - 2010 Airmar Technology Corp.

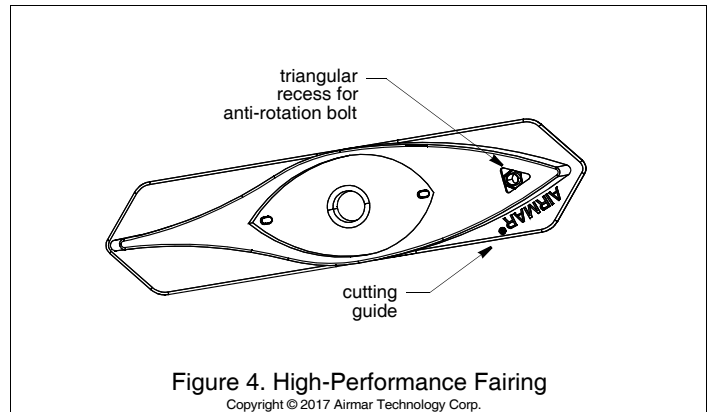

Figure 4. High-Performance Fairing

Copyright © 2017 Airmar Technology Corp.

Installation

Cored Fiberglass Hull—Follow separate instructions on page 5.

Hole Drilling: Transducer

1. Drill a 3mm or 1/8" pilot hole perpendicular to the waterline from inside the hull (Figure 2). If there is a rib, strut or other hull irregularity near the selected mounting location, drill from the outside.
2. Using the appropriate size drill bit or hole saw, cut a hole from outside the hull. *Be sure to hold the drill plumb, so the hole will be perpendicular to the water surface.*

Cutting the High-Performance Fairing

CAUTION: The end of the fairing with the arrows/triangular recess always points forward toward the bow when installed. Be sure to orient the fairing on the band saw, so the angle cut matches the intended side of the hull and not the mirror image.

1. Measure the deadrise angle of the hull at the selected mounting location using an angle finder (Figure 2). *Check to be sure the angle does not exceed 20°.*
2. Tilt the band saw table to the measured angle and secure the cutting fence (Figure 3). Do not exceed 20°.
3. Place the fairing on the table, so the cutting guide rests against the fence (Figure 4). The end with the arrows and triangular

recess will be pointing *toward* you for installation on the starboard side of the boat or *away* from you for installation on the port side.

4. Adjust the cutting fence, so the fairing will be cut in about two equal parts (Figure 3). The section that will become the fairing must be a minimum of 74mm (2-7/8") at its thinnest dimension (Figure 2).
5. Recheck steps 1 through 4. Then cut the fairing.
6. When the boat is underway, especially at high speeds, water will enter any gaps and push against the fairing with considerable force, possibly rotating it. Shape the fairing to the hull as precisely as possible with a rasp or power tool. *If there is a gap of more than 3mm (1/8"), replace the fairing.*
7. Check to be sure the transducer is flush with the fairing. If it is recessed more than 0.5mm (1/64") inside the fairing, you may shim the transducer or carefully file/sand the fairing.
8. The remaining section of the fairing with the cutting guide will be used as the backing block inside the hull. It will provide a level surface for tightening the nuts.

Hole Drilling: Anti-rotation Bolt

To locate and drill the hole for the anti-rotation bolt, use the fairing as a guide. This will ensure that the hole is perpendicular to the waterline and not drilled at the angle of the hull.

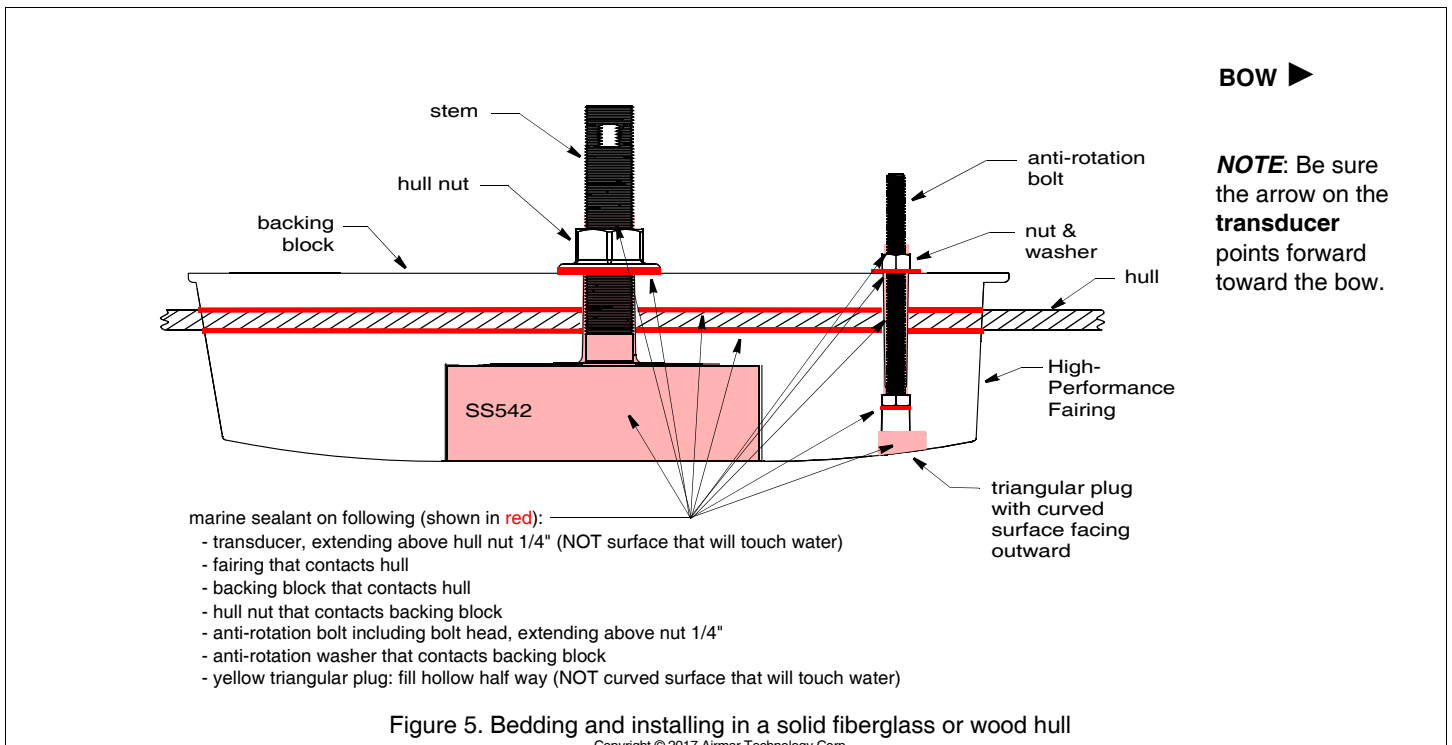
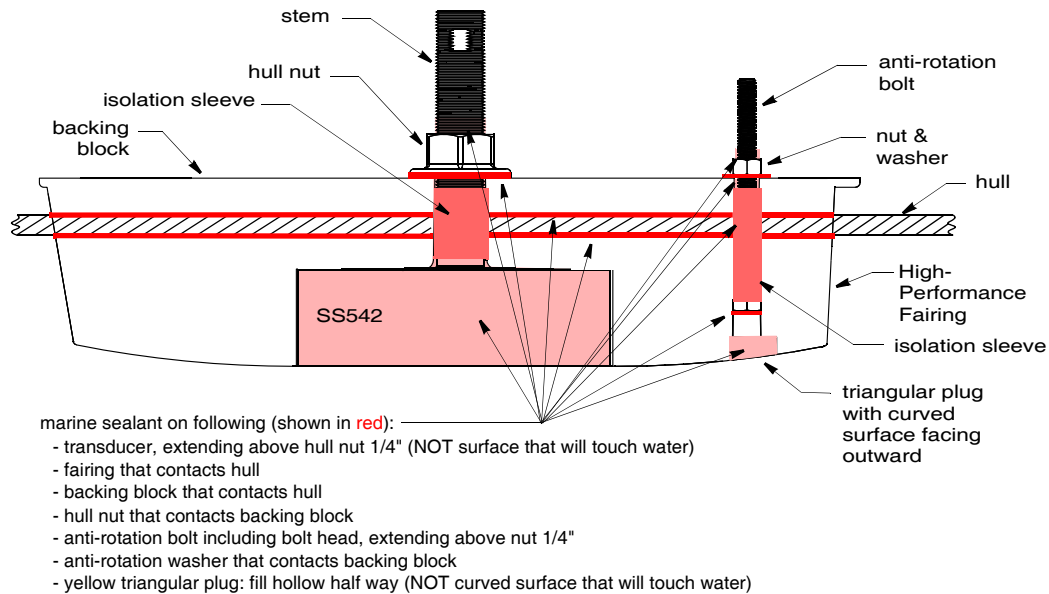

Figure 5. Bedding and installing in a solid fiberglass or wood hull

Copyright © 2017 Airmar Technology Corp.

BOW ►



NOTE: Be sure the arrow on the transducer points forward toward the bow.

Figure 6. Bedding and installing in a metal hull

Copyright © 2017 Airmar Technology Corp.

1. Dry fit the transducer in the fairing. Thread the cables through the large hole in the fairing and through the mounting hole in the hull. Seat the transducer firmly within the recess in the fairing (Figure 5 or 6). *Be sure the arrow on the transducer points toward the triangular recess in the fairing.*
2. Slide the transducer with the fairing in place into the mounting hole. Using the bolt hole in the fairing as your guide, drill a 3mm (1/8") pilot hole through the hull for the anti-rotation bolt.
3. Using the appropriate size drill bit, hold the fairing in place and drill a hole for the anti-rotation bolt.
4. Remove the assembly and cables from the mounting hole.
5. Sand and clean the area around both holes, inside and outside, to ensure that the sealant will adhere properly to the hull. If there is any petroleum residue inside the hull, remove it with either mild household detergent or a weak solvent such as alcohol before sanding.

Metal hull—Remove all burrs with a file and sandpaper.

Bedding the Transducer

CAUTION: Be sure the surfaces to be bedded are clean and dry.

1. Remove the transducer from the fairing.
2. Apply a 2mm (1/16") thick layer of marine sealant to the surface of the transducer that will contact the fairing and up the stem (Figure 5 areas in red). *The sealant must extend 6mm (1/4") higher than the combined thickness of the fairing, hull, backing block, and hull nut.* This will ensure there is marine sealant in the threads to seal the hull and hold the hull nut securely in place.

Stainless steel transducer in a metal hull—To prevent electrolytic corrosion, the stainless steel housing must be isolated from the metal hull. Slide the isolation sleeve over the bedded transducer stem as far down as possible (Figure 6). Apply a 2mm (1/16") thick layer of the marine sealant to the outside of the sleeve.

3. Apply a 2mm (1/16") thick layer of marine sealant to the following surfaces:
 - Fairing that will contact the hull
 - Backing block that will contact the inside of the hull
 - Hull nut that will contact the backing block
4. Thread the transducer cables through the fairing and seat the transducer firmly within the recess. *Be sure the arrow on the transducer points toward the triangular recess in the fairing.*

Installing the Transducer

1. From outside the hull, thread the transducer cables through the mounting hole. Push the stem of the transducer (with the fairing in place) into the mounting hole using a twisting motion to squeeze out excess sealant (Figure 5 or 6). **Be sure the arrow on the transducer points forward toward the bow.**

NOTE: The transducer must be FLUSH with the fairing. If it is recessed more than 0.5mm (1/64") inside the fairing, you may shim the transducer or carefully file/sand the fairing.

Stainless steel transducer in a metal hull—Be sure the isolation sleeve is between the transducer stem and the hull (Figure 6). However, the isolation sleeve must be below the washer and hull nut to prevent the sleeve from interfering with tightening the hull nut.

2. From inside the hull, slide the backing block onto the transducer cables and stem, seating the backing block firmly against the hull. Screw the hull nut in place, but *do not tighten it at this time.*

Bedding & Installing the Anti-rotation Bolt

CAUTION: Be sure the surfaces to be bedded are clean and dry.

1. Apply a 2mm (1/16") thick layer of marine sealant to the anti-rotation bolt *including the flange* (Figure 5 or 6). The sealant must be 6mm (1/4") higher than the combined thickness of the fairing, hull, backing block, washer, and nut. This will ensure that there is marine sealant on the threads to seal the hull and hold the nut securely in place.

Stainless steel transducer in a metal hull—To prevent electrolytic corrosion, the stainless steel anti-rotation bolt must be isolated from the metal hull. Slide the isolation sleeve over the bedded anti-rotation bolt as far down as possible (Figure 6). Apply a 2mm (1/16") thick layer of the marine sealant to the outside of the sleeve.

2. Apply a 2mm (1/16") thick layer of marine sealant to the side of the washer that will contact the backing block.
3. Push the anti-rotation bolt through the fairing and the hull.
4. From inside the hull, screw the washer (sealant side down) and the nut onto the anti-rotation bolt.

Stainless steel transducer in a metal hull—Be sure the isolation sleeve is between the anti-rotation bolt and the hull (Figure 6). However, the isolation sleeve must be below the washer and nut to prevent the sleeve from interfering with tightening the nut.

5. Use slip-joint pliers to tighten the hull nut. Then tighten the nut on the anti-rotation bolt. *Do not over-tighten, crushing the fairing or hull.*

Cored fiberglass hull—Do not over tighten, crushing the hull.
Wood hull—Allow for the wood to swell before tightening the nut.

6. Use marine sealant to *half-fill* the hollow in the yellow triangular plug. Apply a 2mm (1/16") thick layer of marine sealant to the three sides of the plug that form the triangle. The sealant will hold the plug firmly within the fairing and fill any gap between the anti-rotation bolt and the plug.
7. *The yellow triangular plug fits one way only.* Push the yellow plug into the recess in the fairing until it is **FLUSH** with the outside of the fairing. This will squeeze out excess sealant. If necessary, tap it into place with a mallet.

NOTE: *If the triangular plug is slightly recessed within the fairing, use sealant to fill the gap. The plug must be **FLUSH** with the fairing for good performance.*

8. When the boat is underway, especially at high speeds, water will enter any gaps and push against the fairing with considerable force, possibly rotating it. Fill any gaps between the fairing and the hull with marine sealant. **If there is any gap greater than 3mm (1/8"), replace the fairing.** Remove the excess sealant on the outside of the fairing and hull to ensure smooth water flow under the transducer.

Cable Routing & Connecting

CAUTION: If the sensor came with a connector, do not remove it to ease cable routing. If a cable must be cut and spliced, use Airmar's splash-proof Junction Box No. 33-035 and follow the instructions supplied. Removing the waterproof connector or cutting the cable, except when using a water-tight junction box, will void the sensor warranty.

1. Route the cables to the instrument being careful not to tear the cable jacket when passing it through the bulkhead(s) and other parts of the boat. Use grommet(s) to prevent chafing. To reduce electrical interference, separate the transducer cables from other electrical wiring and the engine. Coil any excess cable and secure it in place with cable ties to prevent damage.
2. Refer to the instrument owner's manual to connect the transducer to the instrument.

Checking for Leaks

When the boat is placed in the water, **immediately** check around the transducer for leaks. Note that very small leaks may not be readily observed. Do not leave the boat in the water for more than 3 hours before checking it again. If there is a small leak, there may be considerable bilge water accumulation after 24 hours. If a leak is observed, repeat "Bedding" and "Installing" **immediately** (see page 4).

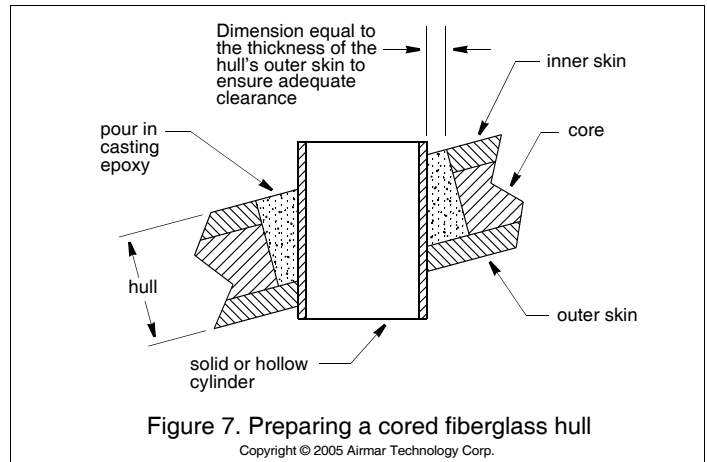

Installation in a Cored Fiberglass Hull

The core (wood or foam) must be cut and sealed carefully. The core *must* be protected from water seepage, and the hull must be reinforced to prevent it from crushing under the hull nut allowing the transducer to become loose.

CAUTION: Completely seal the hull to prevent water seeping into the core.

1. Drill a 3mm or 1/8" pilot hole perpendicular to the waterline from inside the hull (Figure 7). If there is a rib, strut, or other hull irregularity near the selected mounting location, drill from the outside. If the hole is drilled in the wrong location, drill a second hole in a better location. Apply masking tape to the outside of the hull over the incorrect hole and fill it with epoxy.
2. Using the appropriate size drill bit or hole saw, cut a hole from outside the hull through the outer skin only. *Be sure to hold the drill plumb, so the hole will be perpendicular to the water surface.*
3. The optimal interior hole diameter is affected by the hull's thickness and deadrise angle. It must be large enough in diameter to allow the core to be completely sealed.
 Using the appropriate size drill bit or hole saw, cut through the *inner* skin and most of the core from inside the hull keeping the drill perpendicular to the hull. The core material can be very soft. Apply only light pressure to the hole saw after cutting through the inner skin to avoid accidentally cutting the outer skin.
4. Remove the plug of core material, so the *inside* of the outer skin and the inner core of the hull is fully exposed. Sand and clean the inner skin, core, and the outer skin around the hole.
5. Coat a hollow or solid cylinder of the correct diameter with wax and tape it in place. Fill the gap between the cylinder and hull with casting epoxy. After the epoxy has set, remove the cylinder.
6. Sand and clean the area around the hole, inside and outside, to ensure that the sealant will adhere properly to the hull. If there is any petroleum residue inside the hull, remove it with either mild household detergent or a weak solvent, such as alcohol, before sanding.
7. Follow the same procedure to prepare the hull for the anti-rotation bolt. Repeat steps 1 through 6.
8. Proceed with the installation beginning with "Cutting the Fairing" on page 3. Note that all holes are already drilled.

Anti-fouling Paint

Surfaces exposed to salt water must be coated with anti-fouling paint. Use **water-based** anti-fouling paint only. Never use ketone-based paint since ketones can attack many plastics possibly damaging the transducer. Reapply anti-fouling paint every 6 months or at the beginning of each boating season.

Maintenance, Parts & Replacement

Cleaning

Aquatic growth can accumulate rapidly on the transducer's face reducing its performance within weeks. Clean the surface with a Scotch-Brite® scour pad and mild household detergent taking care to avoid making scratches. If the fouling is severe, lightly wet sand with fine grade wet/dry paper.

Replacement Transducer & Parts

The information needed to order a replacement transducer is printed on the cable tag. Do not remove this tag. When ordering, specify the part number, date, and frequency in kHz. For convenient reference, record this information below.

Part No. _____ Date _____ Frequency _____ kHz

Lost, broken, and worn parts should be replaced immediately.

Hull Nut NA

High-Performance Fairing NA

Please contact your Furuno dealer to obtain parts.

