

FURUNO

Installation Manual **MARINE RADAR** **MODEL 1835/MODEL 1935/MODEL 1945**

| | |
|--|------------|
| SAFETY INSTRUCTIONS | i |
| SYSTEM CONFIGURATION | ii |
| EQUIPMENT LISTS | iii |
| 1. HOW TO INSTALL THE SYSTEM | 1-1 |
| 1.1 Display Unit..... | 1-1 |
| 1.2 Antenna Unit for MODEL 1835 | 1-2 |
| 1.3 Antenna Unit for MODEL 1935/MODEL 1945..... | 1-9 |
| 2. CABLE CONNECTION | 2-1 |
| 2.1 Standard Connection | 2-1 |
| 2.2 Data Signal Port | 2-2 |
| 3. HOW TO SET THE EQUIPMENT | 3-1 |
| 3.1 How to Set the Language..... | 3-1 |
| 3.2 How to Set the Purpose and Model | 3-2 |
| 3.3 How to Enter the Initial Settings | 3-3 |
| 4. OPTIONAL EQUIPMENT | 4-1 |
| 4.1 ARP Kit ARP-11 | 4-1 |
| 4.2 Connection of Buzzer and/or Remote Display | 4-4 |
| PACKING LISTS | A-1 |
| OUTLINE DRAWINGS | D-1 |
| INTERCONNECTION DIAGRAMS | S-1 |



SAFETY INSTRUCTIONS

Read these safety instructions before you operate the equipment.



WARNING

Indicates a condition that can cause death or serious injury if not avoided.



CAUTION

Indicates a condition that can cause minor or moderate injury if not avoided.



Warning, Caution



Prohibitive Action



Mandatory Action



WARNING



Do not open the equipment unless totally familiar with electrical circuits and service manual.

Only qualified personnel should work inside the equipment.



Wear a safety belt and hard hat when working on the antenna unit.

Serious injury or death can result if someone falls from the radar mast.

Construct a suitable service platform from which to install the antenna unit.

Serious injury or death can result if someone falls from the radar mast.

Turn off the power at the mains switchboard before beginning the installation.

Fire, electrical shock or serious injury can result if the power is left on or is applied while the equipment is being installed.



CAUTION



Ground the equipment to prevent electrical shock and mutual interference.

Observe the following compass safe distances to prevent deviation of a magnetic compass.

| Unit | Standard | Steering |
|--------------------|----------|----------|
| Display unit | 0.45 m | 0.30 m |
| M1835 Antenna unit | 0.90 m | 0.70 m |
| M1935 Antenna unit | 1.00 m | 0.75 m |
| M1945 Antenna unit | 1.00 m | 0.75 m |



WARNING



Radio Frequency Radiation Hazard

The radar antenna emits electromagnetic radio frequency (RF) energy which can be harmful, particularly to your eyes. Never look directly into the antenna aperture from a close distance while the radar is in operation or expose yourself to the transmitting antenna at a close distance.

Distances at which RF radiation levels of 100, 50 and 10 W/m² exist are given in the table below.

Note: If the antenna unit is installed at a close distance in front of the wheel house, your administration may require halt of transmission within a certain sector of antenna revolution. This is possible - Ask your FURUNO representative or dealer to provide this feature.

Antenna unit:

RSB-0071-057

XN10A-RSB-0070-064, XN10A-RSB-0073-064

XN12A-RSB-0070-059, XN12A-RSB-0073-059

| MODEL | Distance to 100 W/m ² point | Distance to 10 W/m ² point |
|------------|--|---------------------------------------|
| MODEL 1835 | Worst case 0.1 m | Worst case 2.2 m |
| MODEL 1935 | Worst case 0.2 m | Worst case 2.2 m |
| MODEL 1945 | Worst case 0.2 m | Worst case 2.4 m |

Antenna unit:

RSB-0071-057A

XN10A-RSB-0070-064A, XN10A-RSB-0073-064A

XN12A-RSB-0070-059A, XN12A-RSB-0073-059A

| MODEL | Distance to 100 W/m ² point | Distance to 50 W/m ² point | Distance to 10 W/m ² point |
|------------|--|---------------------------------------|---------------------------------------|
| MODEL 1835 | — | Worst case 0.0 m | Worst case 1.0 m |
| MODEL 1935 | — | Worst case 0.2 m | Worst case 1.2 m |
| MODEL 1945 | Worst case 0.1 m | Worst case 0.2 m | Worst case 1.7 m |

SYSTEM CONFIGURATIONS

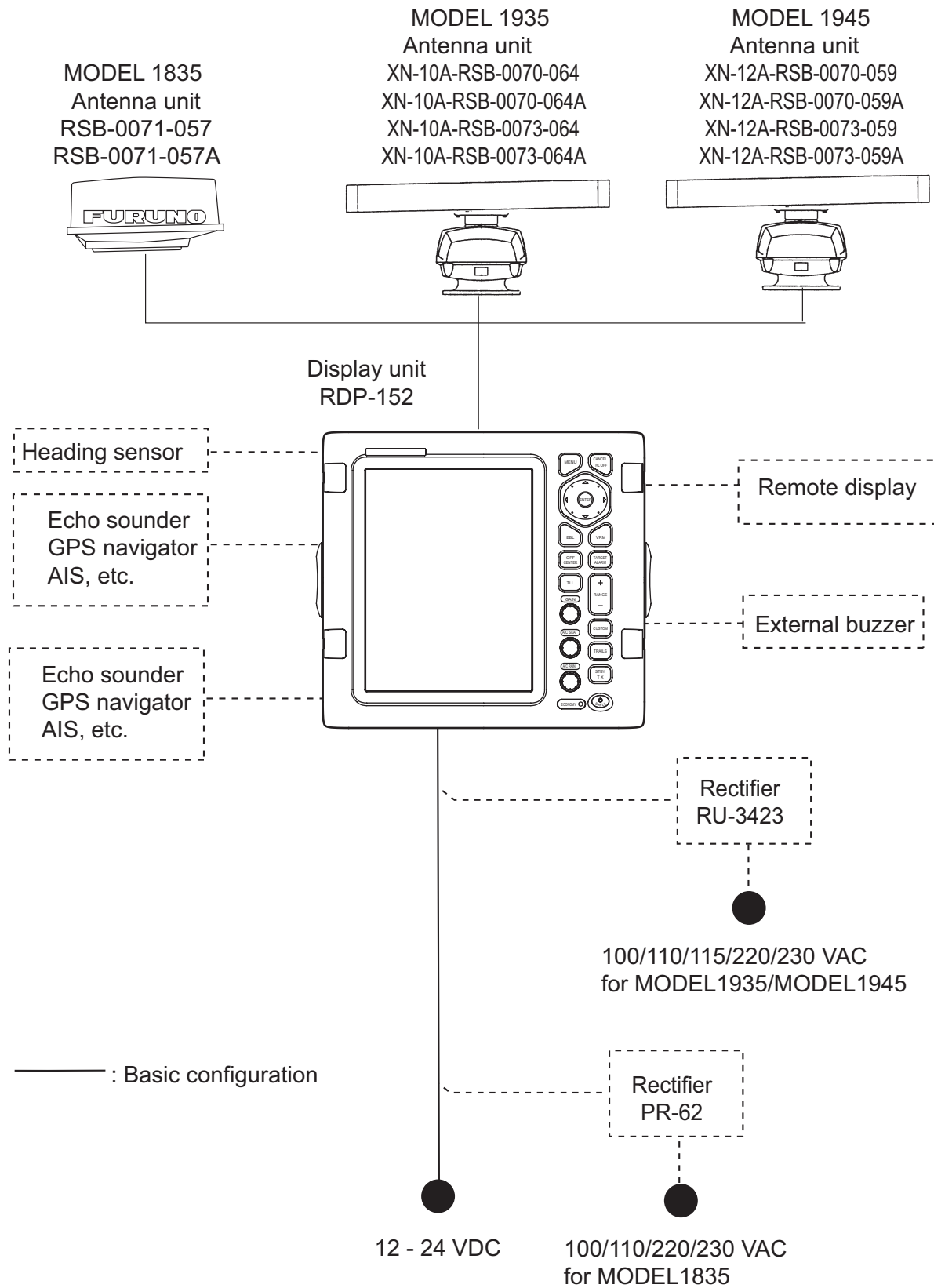

EQUIPMENT LISTS

Standard supply

| Name | Type | Code No. | Qty | Comment |
|------------------------|---------------------|----------------|----------------|--|
| Display unit | RDP-152 | - | 1 | w/Flush mounting sponge 02-160-1201 (1 pc), Self-tapping screw 5x20 SUS304 (4 pcs.) |
| Antenna unit | RSB-0071-057 | - | 1 | Unit for M1835 |
| | RSB-0071-057A | | | Unit for M1935, 24 RPM |
| | XN10A-RSB-0070-064 | | | Unit for M1935, 48 RPM |
| | XN10A-RSB-0070-064A | | | Unit for M1945, 24 RPM |
| | XN10A-RSB-0073-064 | | | Unit for M1945, 48 RPM |
| | XN10A-RSB-0073-064A | | | |
| | XN12A-RSB-0070-059 | | | |
| | XN12A-RSB-0070-059A | | | |
| | XN12A-RSB-0073-059 | | | |
| | XN12A-RSB-0073-059A | | | |
| Installation materials | CP03-21800 | 000-080-014 | 1 | 10 m Signal cable for M1835 |
| | CP03-21810 | 000-080-015 | | 15 m Signal cable for M1835 |
| | CP03-21820 | 000-080-016 | | 20 m Signal cable for M1835 |
| | CP03-21830 | 000-080-017 | | 30 m Signal cable for M1835 |
| | CP03-33000 | 000-014-604 | | 5 m Signal cable for M1935/1945 |
| | CP03-33010 | 000-014-605 | | 10 m Signal cable for M1935/1945 |
| | CP03-33020 | 000-014-606 | | 15 m Signal cable for M1935/1945 |
| | CP03-33030 | 000-014-607 | | 20 m Signal cable for M1935/1945 |
| | CP03-33040 | 000-014-608 | | 30 m Signal cable for M1935/1945 |
| | 02-160-1201 | 100-344-030-10 | | 1 |
| | MJ-A3SPF0017-050ZC | 000-157-995-10 | 1 | 5 m power cable with 10 A fuse |
| | CP03-16901 | 001-051-990 | 1 set | For antenna unit of M1835 |
| | CP03-18401 | - | | For antenna unit of M1935/1945 |
| | Accessories | 19-028-3125-1 | 100-360-671-10 | 1 |
| Spare parts | SP03-12200 | 000-086-965 | 1 set | Fuse label 03-129-1512 1 pc, Fuse FGBO 125V 10A PBF 2 pcs Fuse FGBO-A 125V 5A PBF 2 pcs |

Note: The name for MODEL1835, MODEL1935, MODEL1945 is shortened to M1835, M1935, M1945 in this manual.

Optional supply

| Name | Type | Code No. | Qty | Comment |
|------------------|---------------------|----------------|-----|--|
| Rectifier | PR-62 | - | 1 | For M1835 |
| | RU-3423 | 000-030-443 | | For M1935/1945 |
| External buzzer | OP03-21 | 000-030-097 | 1 | |
| Cable assy. | MJ-B24LPF0010-100+R | 000-147-880-12 | 1 | For remote display, 10 m |
| | MJ-B24LPF0010-200+R | 000-147-881-12 | 1 | For remote display, 20 m |
| | MJ-B24LPF0010-300+R | 000-147-882-12 | 1 | For remote display, 30 m |
| | MJ-A10SPFW0001+R | 001-074-600-10 | 1 | Two-way cable for remote display/external buzzer |
| | MJ-A6SPF0007-100C | 000-159-695-10 | 1 | For heading sensor, 10 m |
| | MJ-A7SPF0007-050C | 000-154-028-10 | 1 | Used for navaid and external buzzer, 5 m |
| ARP kit | ARP-11 | 008-523-050 | 1 | ARP Board |
| Mounting bracket | OP03-208 | 001-078-340 | 1 | For antenna unit of M1835 |
| Connector | MJ-A6SPF3A+ | 000-154-034-10 | 10 | For 6P connector |
| | MJ-A7SPF3A+ | 000-154-030-10 | 10 | For 7P connector |

1. HOW TO INSTALL THE SYSTEM

1.1 Display Unit

Select a location for the display unit by following the information shown below.

- The unit is waterproof, but FURUNO recommends that you install the display unit in a cabinet.
- Keep the unit away from direct sunlight.
- The temperature and humidity must meet the requirements shown in the equipment specifications.
- Set the unit away from the exhaust pipes and vents.
- The installation location must have enough cool air.
- Install the unit where shock and vibration meet the requirements shown in the equipment specifications. If there is heavy vibration, vertically install the display unit on the hanger.
- Keep the unit away from the equipment that creates an electromagnetic field, for example, a motor and generator.
- For maintenance and checking, leave enough space at the sides and rear of the unit referring to the outline drawing and provide some additional length in cables.
- Follow the recommended compass safe distances shown on page i to prevent the interference to a magnetic compass.

How to install the display unit

How to install the display unit on a desktop or the overhead

Follow the procedure shown below to install the display unit on a desktop or the overhead.

See the outline drawing on page D-3 for details.

1. Fasten the hanger with four self-tapping screws.
2. Set the knob bolts into the display unit.
3. Set the display unit to the hanger, and tighten the knob bolts.
4. Attach the hard cover to protect the LCD.

Note: For the overhead installation, make sure the location is strong enough to hold the unit. If necessary, fasten the hanger with the bolts, nuts and washers (local supply).

How to install the display unit in a console

Follow the procedure shown below to install the display unit in a console.

1. Prepare a hole in the location whose dimensions are 274 (W) x 252 (H) mm.
2. Make four pilot holes. See the outline drawing at the back of this manual for additional information.
3. Set a flush mount sponge supplied as an installation materials to the backside of the unit.
4. Set the unit to the hole.
5. Open the four covers and fasten the unit with four self-tapping screws (5 x 20) supplied.

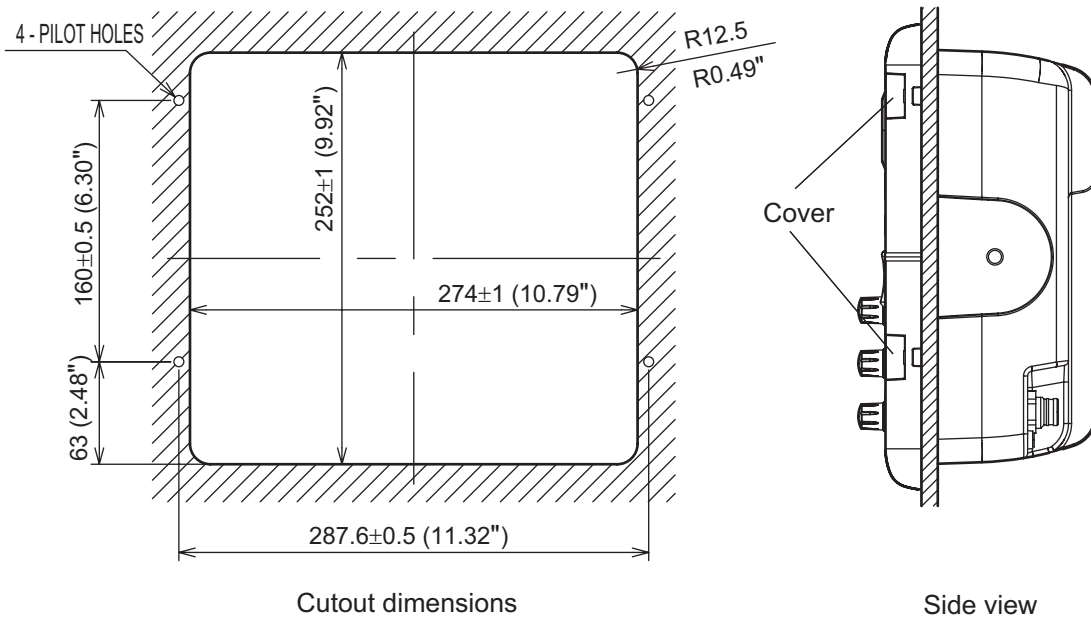

1.2 Antenna Unit for MODEL1835

How to select the location for the antenna unit

When you select an installation location for the antenna unit, remember the following points.

- Install the antenna unit on a solid location, for example radar arch or on a mast on a platform. (For sailboats, a mounting bracket is optionally available.) You must put the antenna unit where there is a good complete view. Make sure that no part of the superstructure is within the scanning beam. Any obstruction causes shadow sectors. For example, a mast with a diameter smaller than the horizontal beamwidth causes only a small blind sector. A horizontal spreader or crosstrees in the same horizontal plane creates a large obstruction. Install the antenna unit above a horizontal spreader or crosstrees.

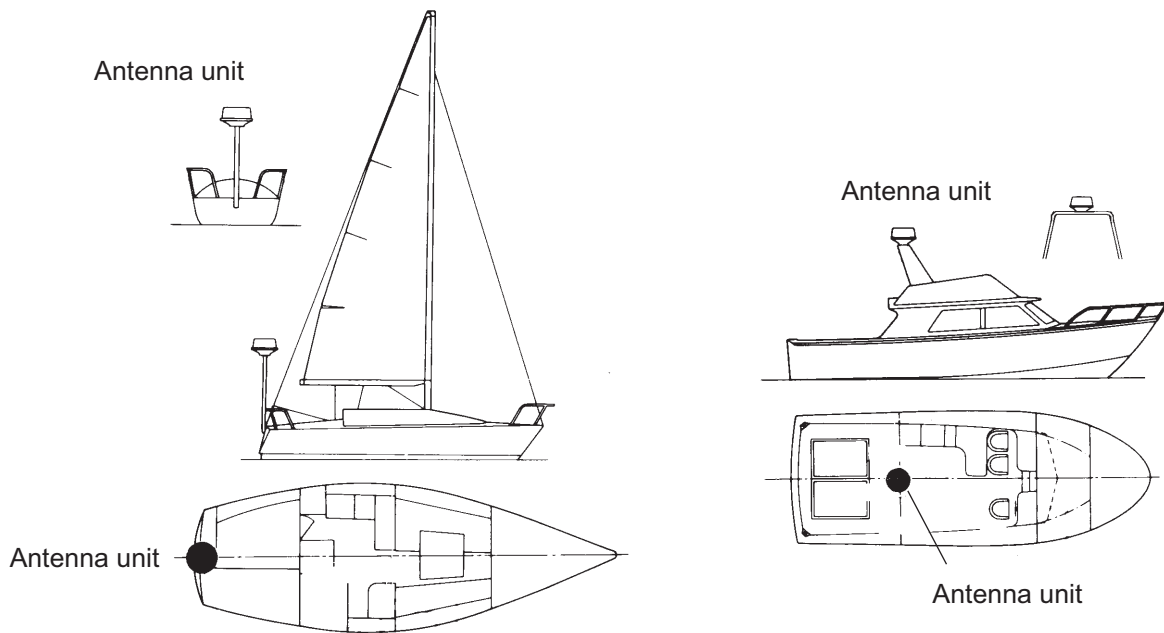

Normal position of the antenna unit on the sailboat and powerboat

To reduce the electrical interference, do not run the antenna cable near other electrical equipment. Also do not run the cable in parallel to power cables.

Make sure that you follow the compass safe distance shown on page i to prevent the interference to a magnetic compass.

How to install the antenna unit

1. Open the packing box of the antenna unit with great caution.
2. Loosen the four bolts at the base of the radome to remove the radome cover.

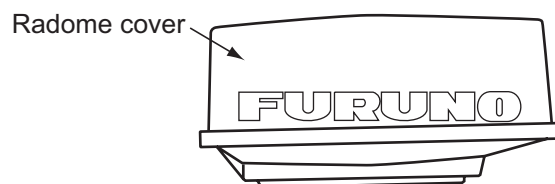

Antenna unit

The location where you install the antenna unit must be parallel to the waterline. Make five holes in the installation location. See the outline drawing at the end of this manual for dimensions. A target echo returned from the bow direction must be shown on the zero degree position on the screen. When you make holes, make sure the holes are parallel to the fore-and-aft line.

3. Prepare a platform of 5 to 10 millimeters in thickness for the antenna unit.

The optional mounting bracket lets you install the antenna unit on a sailboat mast. (Refer to page 1-8 for information.) Find the cable entry on the radome base. Set the radome base so that the cable entry is toward the stern.

Antenna unit: RSB-0071-057
 XN10A-RSB-0070/0073-064
 XN12A-RSB-0070/0073-059

Antenna unit: RSB-0071-057A
 XN10A-RSB-0070/0073-064A
 XN12A-RSB-0070/0073-059A

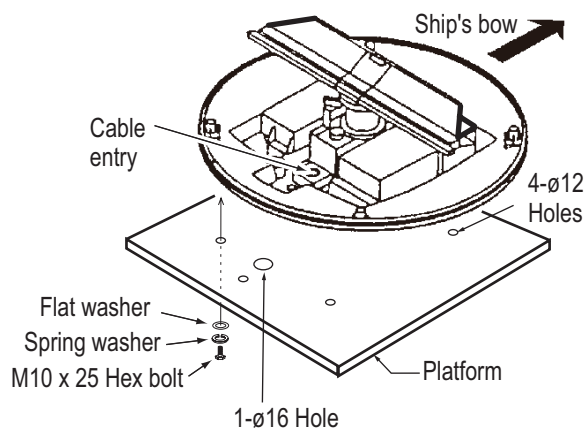
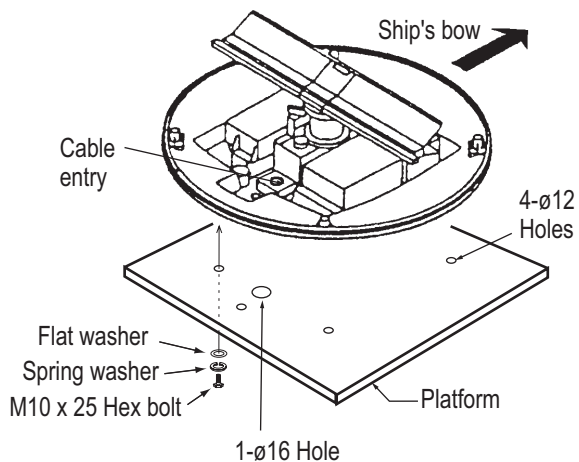

Antenna unit, cover removed

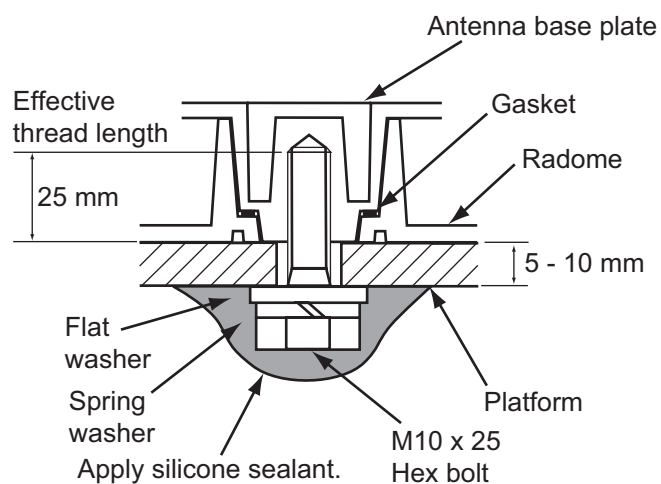

How to fasten the radome base to the platform

Wiring and preparation

4. Make a hole of at least 20 millimeters in diameter through the deck or bulkhead to run the signal cable. (To prevent electrical interference, do not run the signal cable near other electrical equipment. Do not run the cable in parallel to power cables.) Set the cable through the hole. Close the hole with the sealing compound for waterproofing.
5. Remove three shield covers in the radome.

6. Loosen four screws and remove the cable clamping plate and the gasket.

Antenna unit: RSB-0071-057

XN10A-RSB-0070/0073-064

XN12A-RSB-0070/0073-059

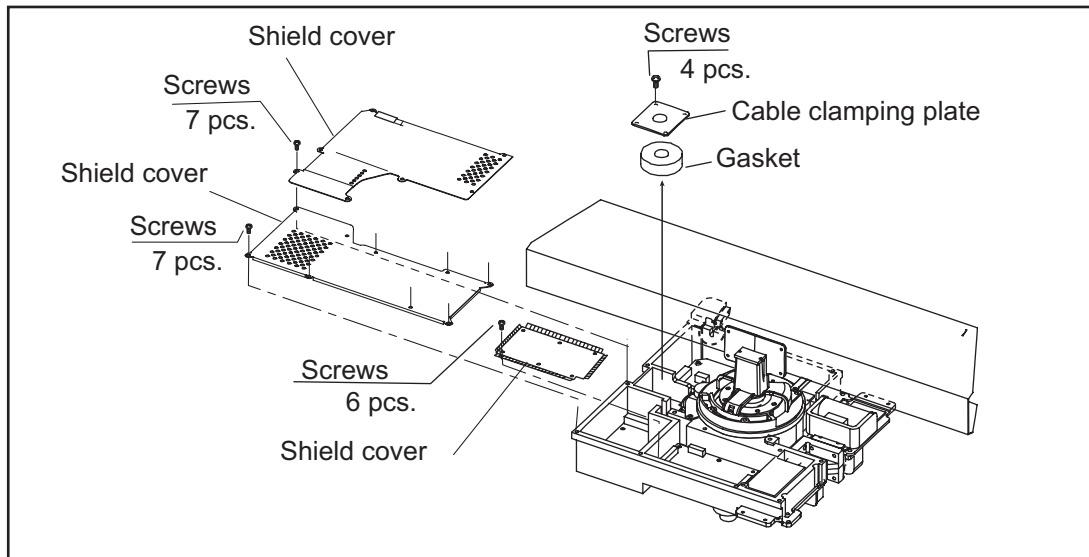

Antenna unit: RSB-0071-057A

XN10A-RSB-0070/0073-064A

XN12A-RSB-0070/0073-059A

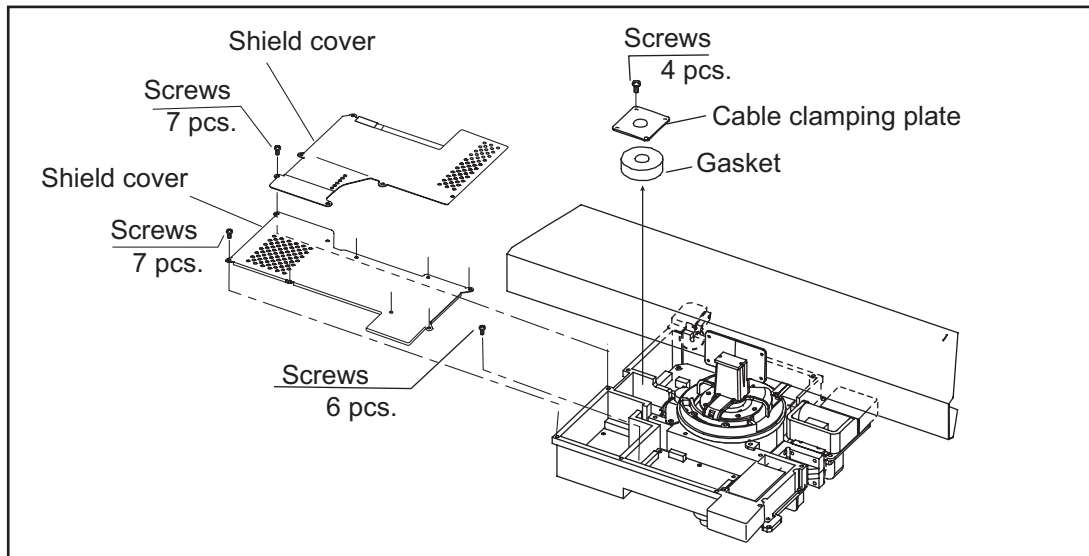

Antenna unit, inside view

7. Set the signal cable through the hole at the bottom of the radome base.
8. Fasten the signal cable with the cable clamping plate and gasket. Connect the shield and vinyl wire to the ground by one of the screws of the cable clamping plate.

9. Connect the wire to the RF unit, referring to the illustration on the next page.

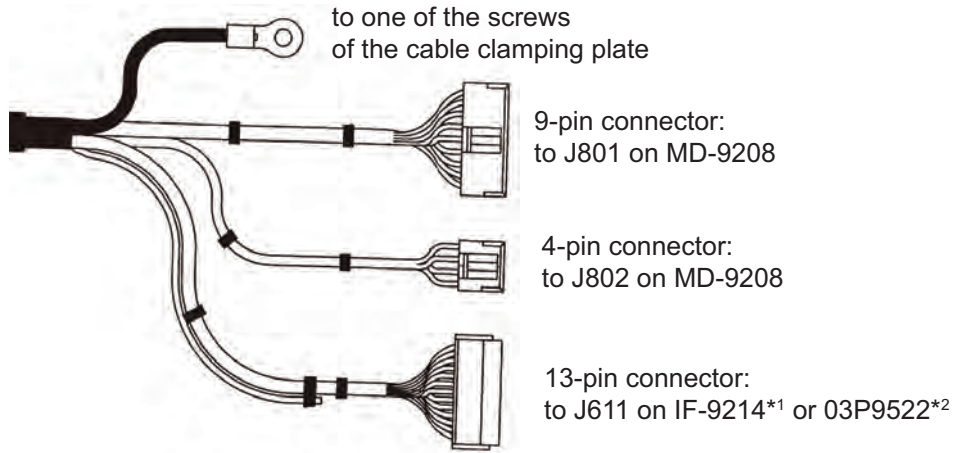

*1: For Antenna unit RSB-0071-057, XN10A-RSB-0070/0073-064 and XN12A-RSB-0070/0073-059

*2: For Antenna unit RSB-0071-057A, XN10A-RSB-0070/0073-064A and XN12A-RSB-0070/0073-059A

Signal cable, the side of antenna unit

Antenna unit: RSB-0071-057
XN10A-RSB-0070/0073-064
XN12A-RSB-0070/0073-059

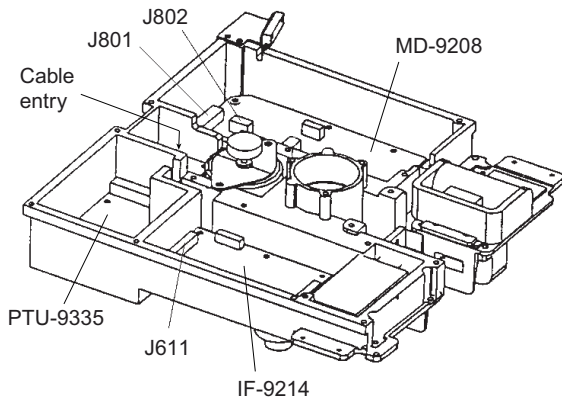

Antenna unit: RSB-0071-057A
XN10A-RSB-0070/0073-064A
XN12A-RSB-0070/0073-059A

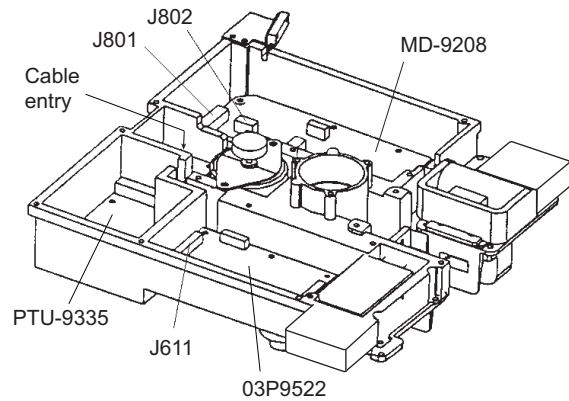

RF unit

10. Attach the EMC core supplied as shown below.

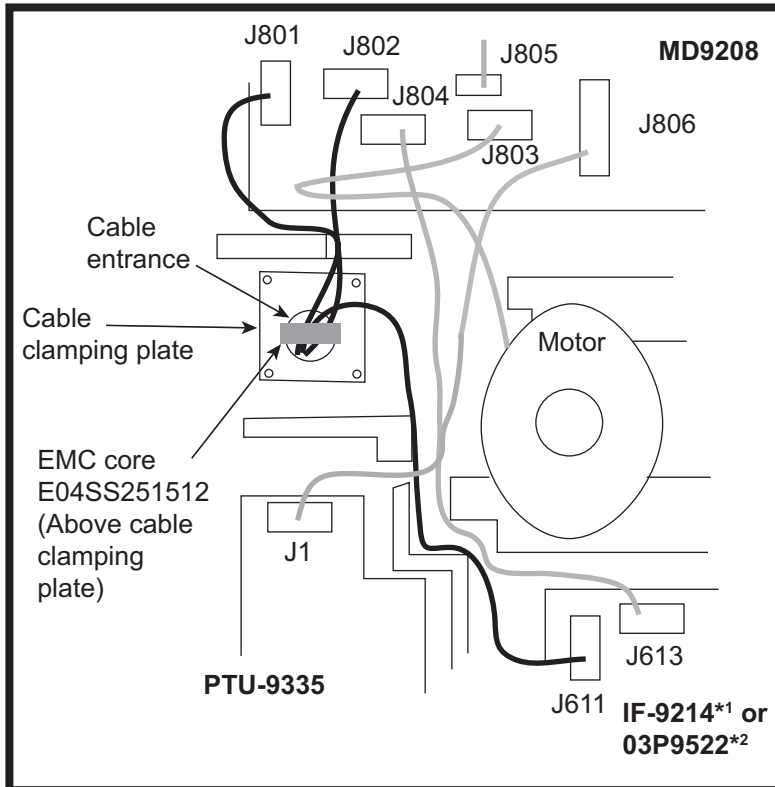

How to attach EMC core

11. Attach the shield covers. Make sure the cable is not caught by the cover.

12. Attach the radome cover. Align the triangle mark on radome cover with that on radome base.

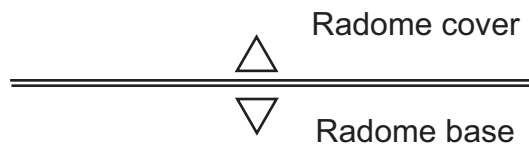

How to attach the radome cover

13. Fasten the radome bolts.

How to install the optional mounting bracket

The optional mounting bracket lets you fasten the antenna unit to a mast on a sailboat.

Mounting bracket kit

Type: OP03-208

Code No.: 001-078-340

Table Contents of mounting bracket kit

| | Type | Code | Qty |
|-------------------|---------------|----------------|-----|
| Hex head bolt | M4x12 | 000-162-956-10 | 4 |
| Hex head bolt | M8x20 | 000-162-955-10 | 10 |
| Mounting plate | 03-018-9001-0 | 100-206-740-10 | 1 |
| Support plate (1) | 03-018-9005-0 | 100-206-780-10 | 1 |
| Support plate (2) | 03-018-9006-0 | 100-206-790-10 | 1 |
| Bracket (1) | 03-018-9002-3 | 100-206-753-10 | 1 |
| Bracket (2) | 03-018-9003-3 | 100-206-763-10 | 1 |
| Fixing plate | 03-018-9004-3 | 100-206-773-10 | 2 |

Assemble the mounting bracket and fasten the mounting bracket to a mast. Fasten the antenna unit to the bracket.

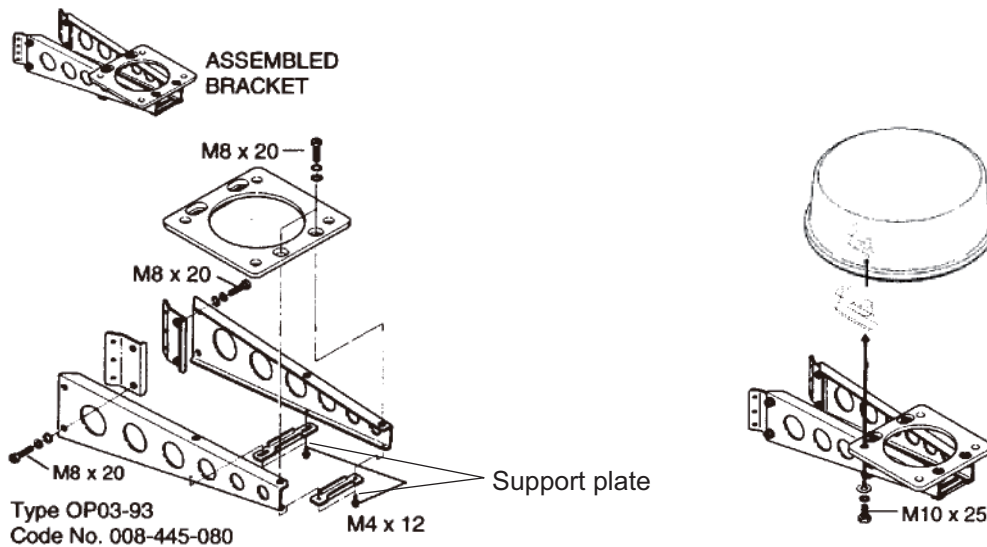

(A) Assembling the mounting bracket

(B) Fastening antenna to mounting bra

How to assemble and install the optional mounting bracket

1.3 Antenna Unit for MODEL1935/MODEL1945

How to select the location for the antenna unit

- The antenna unit is installed either on top of the wheelhouse or a platform on the radar mast. Install the antenna unit where there is a good complete view. Any obstruction causes blind sectors. For example, a mast with a diameter smaller than the horizontal beamwidth of the radiator causes only a small blind sector. A horizontal spreader or crosstrees in the same horizontal plane creates a large obstruction. Install the antenna unit above, or below a horizontal spreader or crosstrees.
- You cannot put the antenna unit where there is a completely clear view in all directions. Make sure you check for blind sectors on the radar screen after you have installed the radar.
- To reduce the electrical interference, do not run the signal cable near other electrical equipment. Also do not run the cable in parallel to power cables.
- A magnetic compass gives error if the antenna unit is installed near the magnetic compass. Follow the compass safe distances shown in the SAFETY INSTRUCTIONS to prevent the interference to a magnetic compass.
- Do not apply paint to the radiator aperture. The radar wave cannot be transmitted if there is paint on the radiator.
- If this radar is installed on a large vessel, follow the points shown below:
 - The length of the signal cable between the antenna unit and the display unit is max. 30 m.
 - The output from a funnel or exhaust vent decreases aerial performance and hot gases can damage the radiator. The antenna unit must not be installed where the temperature is more than 55°C.
- The antenna unit can be installed on the bridge, a common mast, or the radar mast.

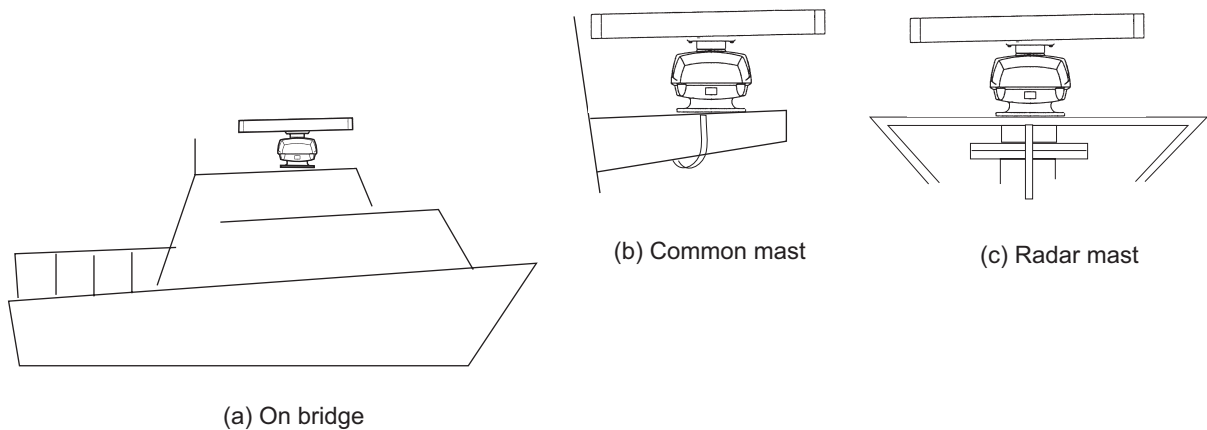

Installation procedure

Refer to the outline drawing at the back of this manual for the dimensions. Make five holes in the platform. Four holes to fasten the antenna unit and one hole for the signal cable.

How to fasten the radiator to the radiator bracket

See the packing list at the back of this manual for the installation materials.

1. Remove the radiator cap from the radiator bracket.
2. Apply the silicone sealant to the surface of the antenna radiator and the radiator bracket. See the figure shown below for the location.

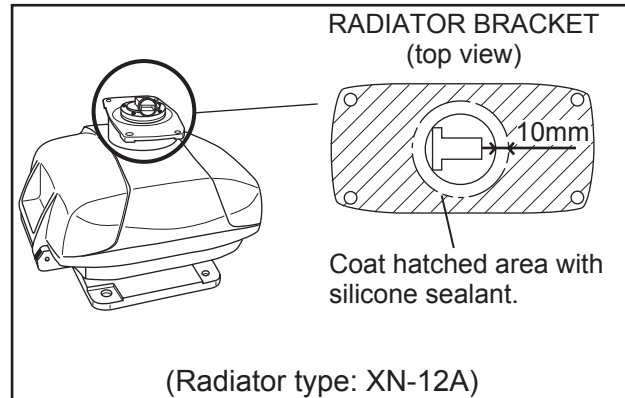
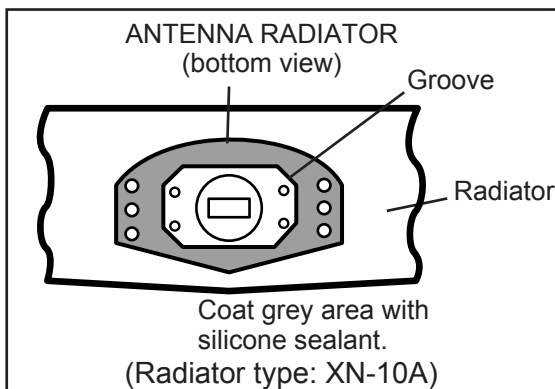

3. Apply the silicone sealant to the threads in the four holes on the antenna radiator.
4. Apply the grease to the O-ring and set the O-ring to the radiator bracket.
5. Set the antenna radiator on the radiator bracket.
6. Apply the silicone sealant to the radiator bolts (4 pieces). Fasten the antenna radiator to the radiator bracket with the radiator bolts, flat washers and spring washers.

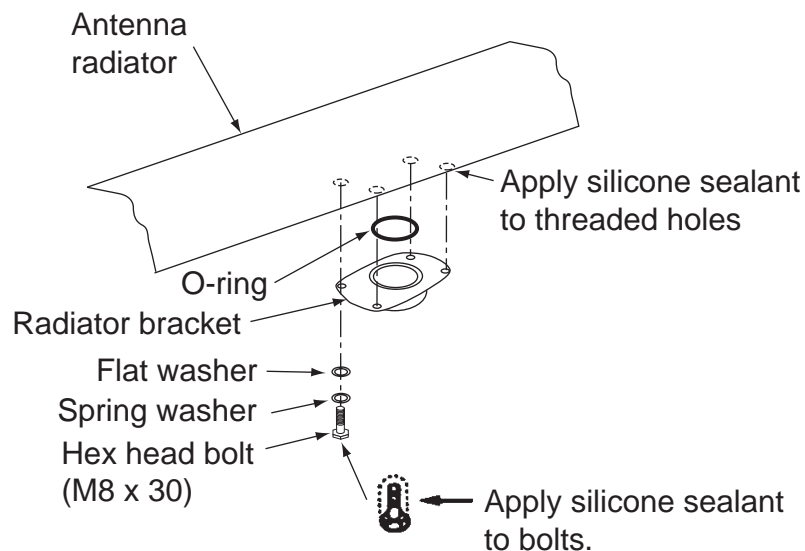

How to fasten the antenna radiator to the radiator bracket

How to install the antenna unit

You can install the antenna unit by one of the two methods shown below.

- Use the outside holes
- Use the inside holes

How to use outside holes of the antenna housing

Use the hex head bolts (supplied) to install the antenna unit as shown in the illustration below.

1. Put the rubber mat (supplied) on the platform.

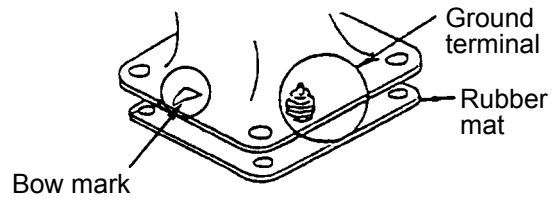

Location of rubber mat

2. Put the antenna unit on the rubber mat. Align the position of the antenna unit as shown in the illustration below.

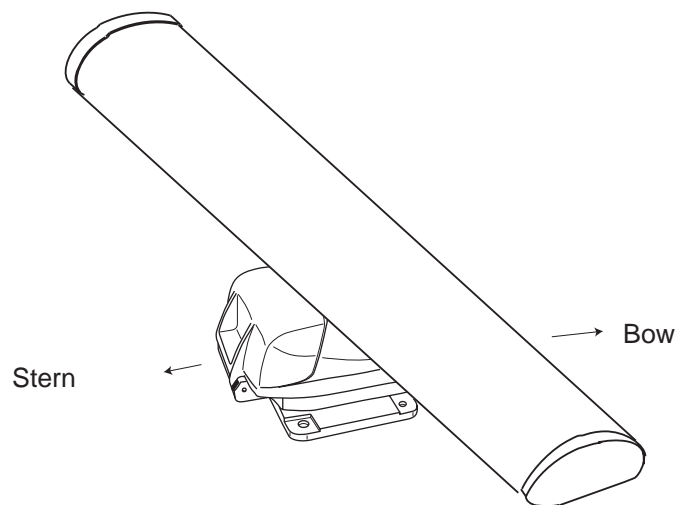

Antenna unit



CAUTION

Do not lift the Antenna unit by the radiator; lift it by the housing.

The radiator may be damaged.

- Set four hex head bolts (M12x60, supplied) and seal washers (supplied) from the top of the antenna housing, as shown below.

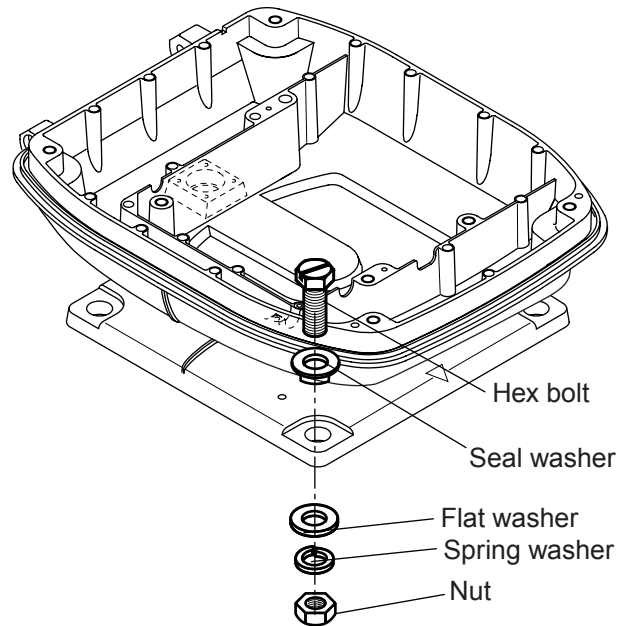

How to set the antenna unit chassis

- Set the flat washers (M12, supplied), spring washers (supplied) and nuts (supplied) to the hex head bolts. Tighten by turning the nuts. Do not tighten by turning the hex head bolts, to prevent damage to the seal washers.

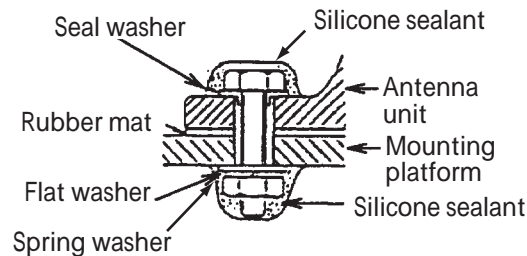

How to fasten the antenna unit to the platform

- Apply the anticorrosive sealant to the flat washers, spring washers, nuts and visible parts of bolts.
- Prepare the ground point on the platform. Use an M6x25 bolt, nut and flat washer (supplied). The ground point must be within 300 mm from the ground terminal on the antenna unit.
- Run the ground wire (RW-4747, 340 mm, supplied) between the ground terminal and the ground point.

8. Apply the silicone sealant to the ground terminal and ground point as shown below.

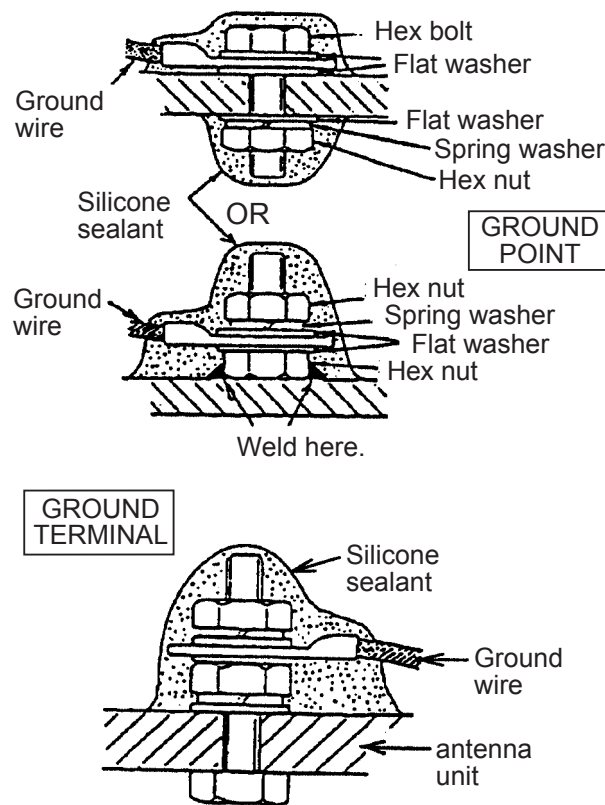

How to apply the silicone sealant to the ground point and ground terminal

How to use the inside holes of the antenna housing

This method requires removal of the RF unit from the antenna unit to access the inside fixing holes. Use four hex head bolts, flat washers, spring washers and nuts (local supply) to install the antenna unit. Check the length of bolts before you install.

1. Loosen four bolts on the cover to open the antenna unit.
2. Disconnect the connector connected between the upper chassis and the lower chassis.
3. Remove two hex head bolts (M8x25) to separate the upper chassis from the lower chassis.
4. Loosen four pan head screws to remove the cover from the pc board.
5. Remove the connector from the RF unit.
6. Loosen four hex head bolts to remove the RF unit.

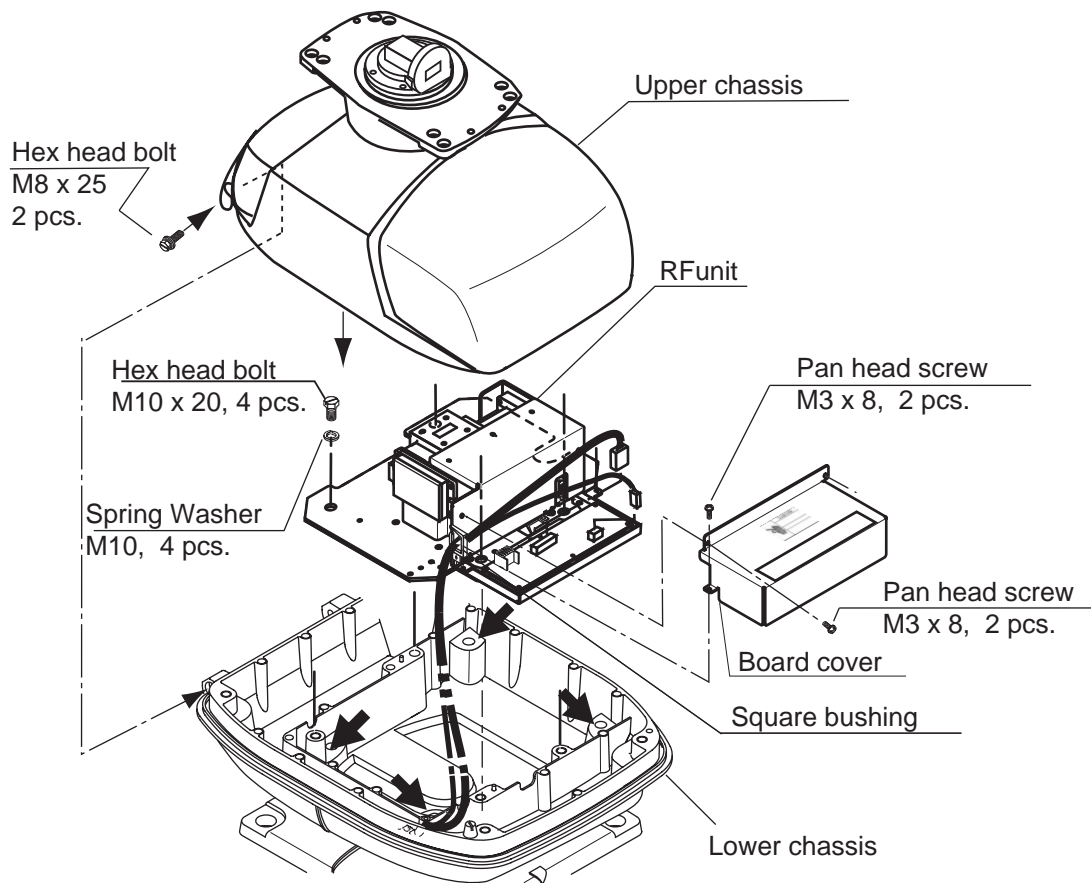

Antenna unit chassis, upper chassis separated

7. Set the corrosion-proof rubber mat (supplied) to the support platform.
8. Cut the rubber bushings in the fixing holes and put four bolts from the inside of the lower chassis. Fasten the lower chassis to the support platform with the spring washers, flat washers and nuts (local supply). Apply the silicone sealant to the flat washers, nuts and visible parts of bolts.
9. Assemble the RF unit, cover and chassis.
10. Set four caps (supplied) into the outside fixing holes.
11. Prepare the ground point on the platform. Use an M6x25 bolt, nut and flat washer (supplied). The ground point must be within 300 mm from the ground terminal on the antenna unit.
12. Run the ground wire (RW-4747, 340 mm, supplied) between the ground terminal and the ground point.
13. Apply the silicone sealant to the ground terminal and ground point. See the illustration on page 1-13 for instructions.

How to connect the signal cable

The signal cable runs from the display unit to the antenna unit. To reduce the electrical interference, do not run the signal cable near other electrical equipment. And do not run the cable in parallel to power cables. Put the cable through the hole and apply the sealing compound around the hole for waterproofing.

1. Loosen four bolts, open the antenna cover, and set the stay.

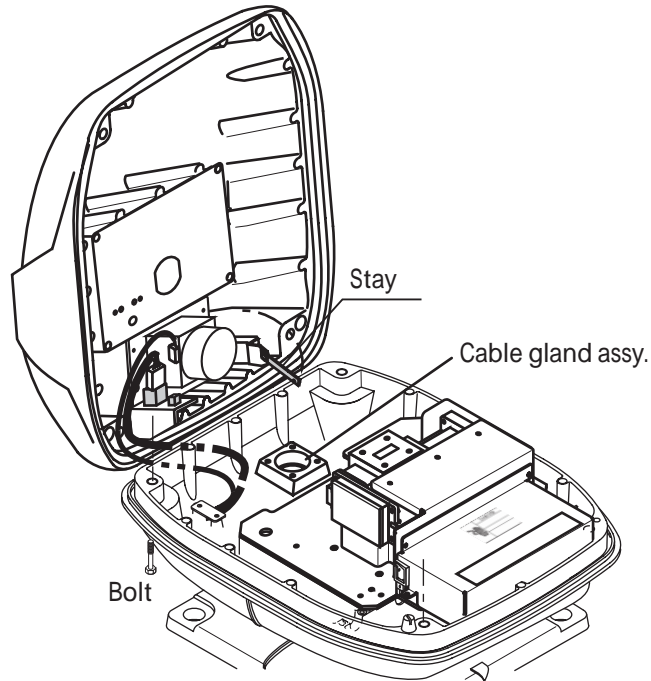

Antenna unit chassis, cover opened

2. Loosen the cable gland assembly (plate, gasket, flat washer).
3. Put the signal cable with the connector through the bottom of the antenna unit chassis. Put the cable through the gland assembly as shown below.

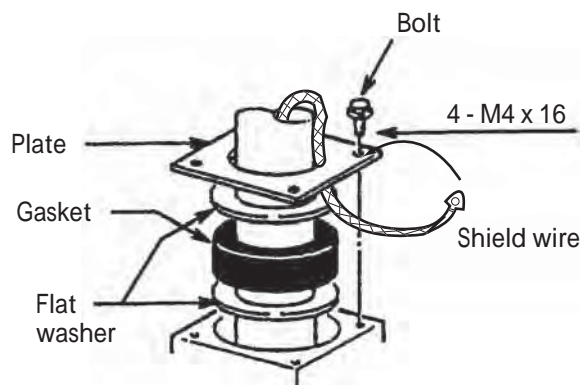

How to put the signal cable through the cable gland assembly

4. Fasten the crimp-on lug of the shield wire to one of the four fixing bolts of the cable gland assembly.

5. Put the signal cable so that no more than 4 cm of the sheath is visible, as shown in the figure below. Tighten the fixing bolts.

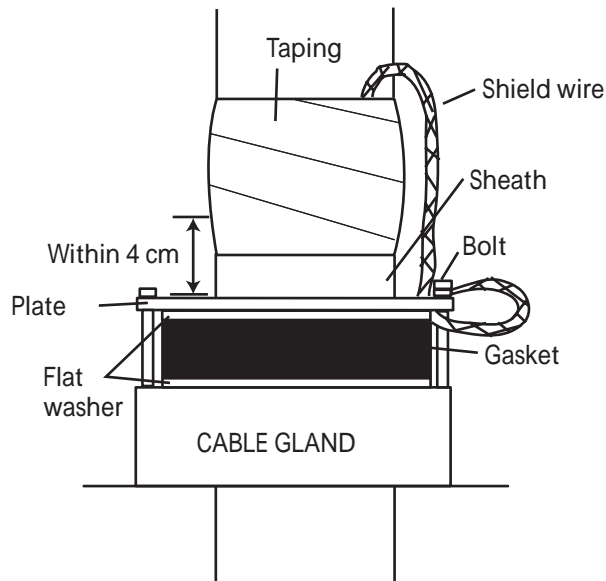

How to fasten signal cable in cable gland

6. Loosen four screws in the figure shown below and open the cover.

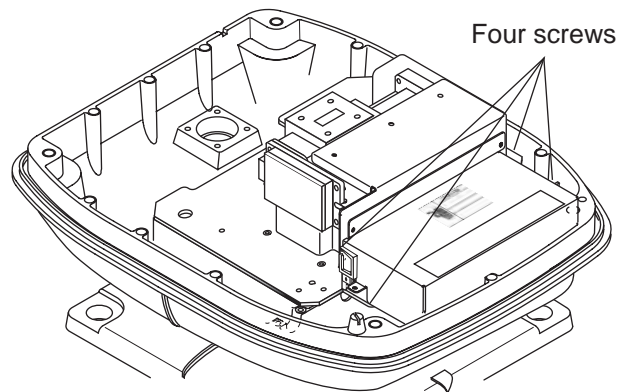

Antenna unit chassis, cover opened

7. Put the signal cable through the cable protector.

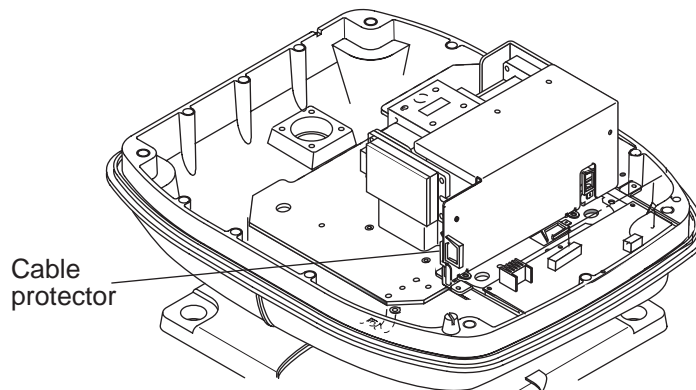

Antenna unit chassis, cover opened

8. Connect the signal cable to the RTB Board (03P9249). See the interconnection diagram and the figure shown below.
9. Attach three EMI cores to the signal cable as shown below.

Antenna unit: RSB-0071-057
 XN10A-RSB-0070/0073-064
 XN12A-RSB-0070/0073-059

Antenna unit: RSB-0071-057A
 XN10A-RSB-0070/0073-064A
 XN12A-RSB-0070/0073-059A

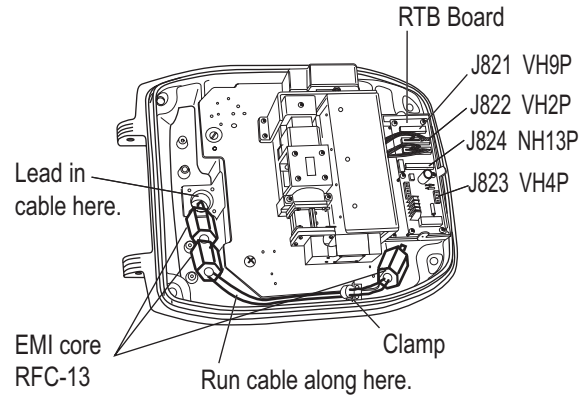
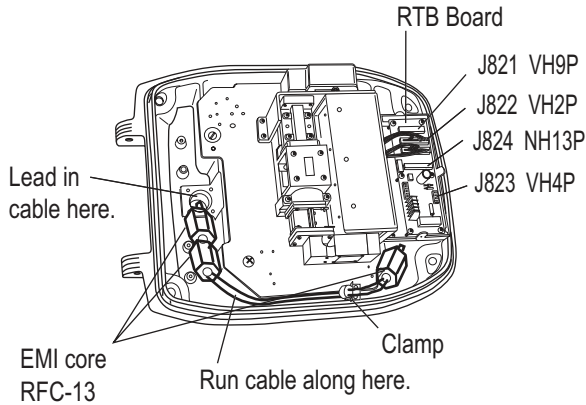

Antenna unit chassis, cover opened

10. Fasten the signal cable with the cable clamp.
11. Undo the stay and close the cover. Securely Fasten the scanner bolts.

Note: When you close the cover, set the gaskets to the grooves in the bottom chassis, then tighten the bolts.

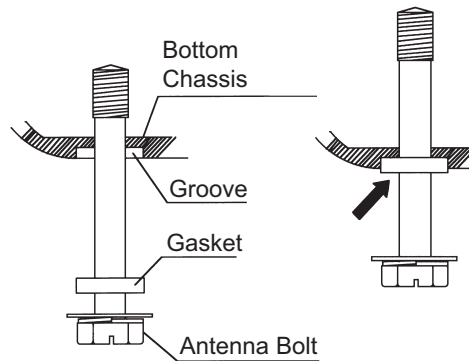

Torque : 9.8 ±0.1 Nm

2. CABLE CONNECTION

2.1 Standard Connection

Connect all cables at the rear of the display unit.

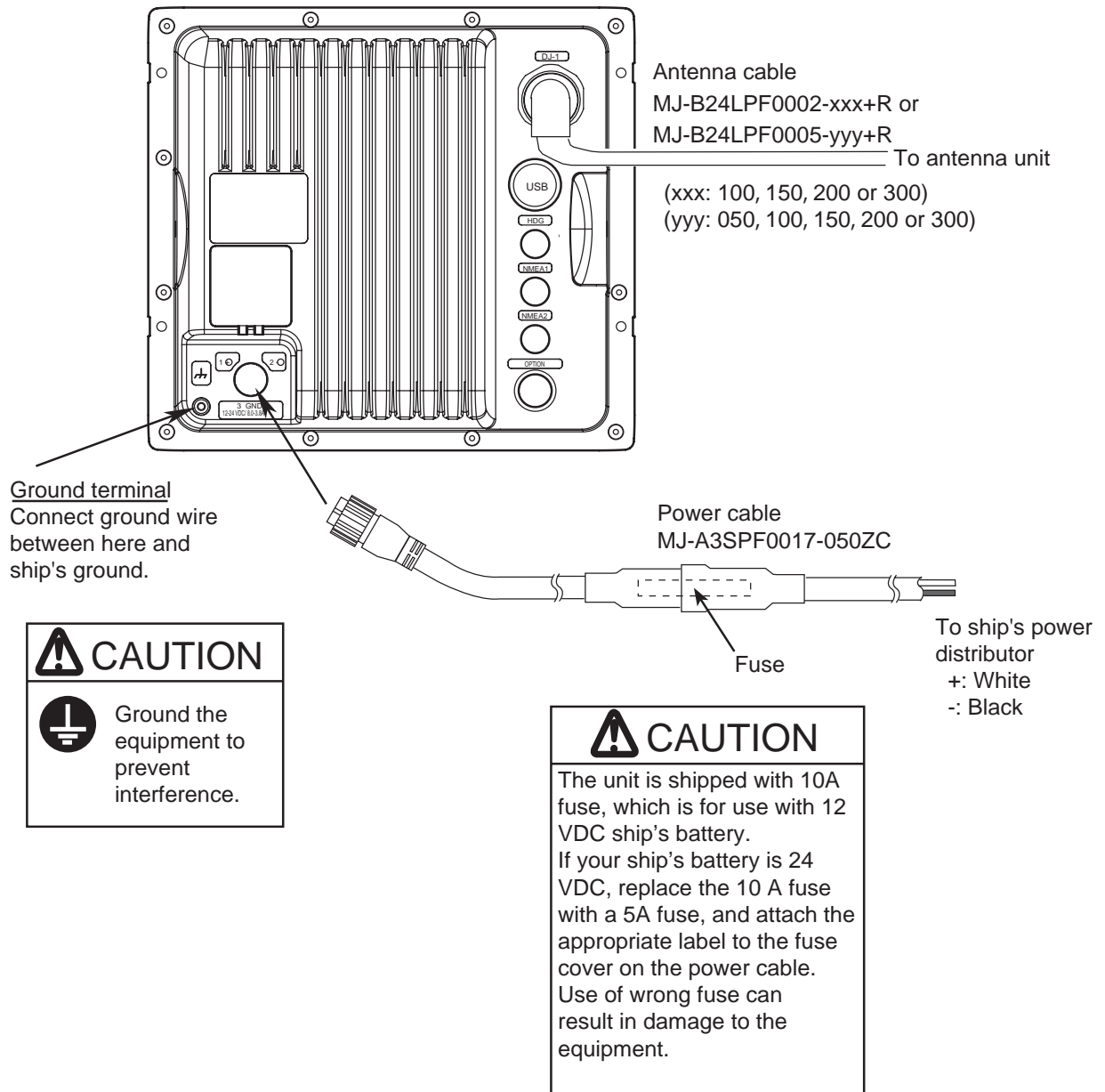

Display unit, rear view

2.2 Data Signal Port

Connect external equipment(s) to the ports on the rear panel as shown below.

| NMEA1 (7P), NMEA2 (7P) (NMEA in / out) | HDG (6P) | OPTION (10P) |
|---|---|-------------------------------------|
| GPS sensor, AIS GPS navigator, echo sounder, etc. | Heading sensor (Example AD-100, SC-50, SC- 110) | External buzzer Remote display |
| Necessary cable MJ-A7SPF0007-050C | Necessary cable MJ-A6SPF0007-100C | Necessary cable See section 4.2. |

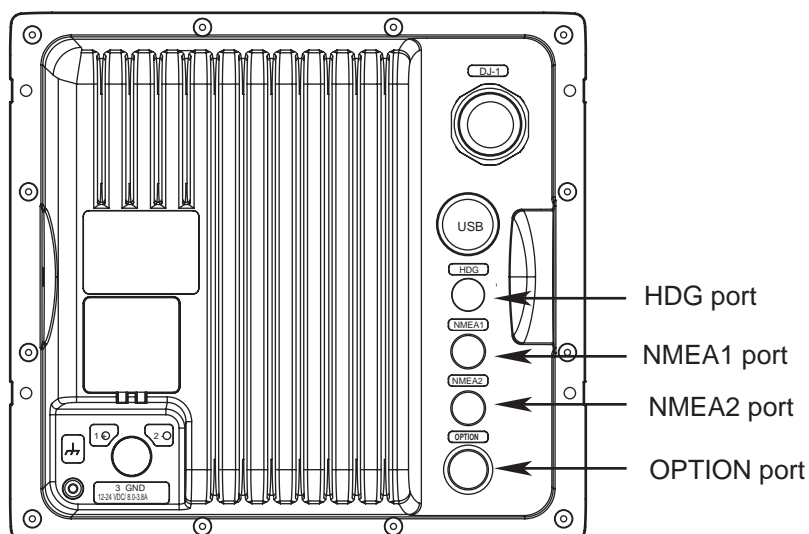

The Model 1835/1935/1945 can receive the following NMEA 0183 format sentence from other equipment.

- Position GNS>GGA>RMC> GLL
- Course true VTG>RMC
- Course magnetic VTG>RMC (true)
- Speed over ground VTG>RMC
- Speed related to water VHW
- Distance to waypoint BWR>BWC>RMB
- Destination waypoint, true BWR>BWC>RMB
- Destination waypoint, magnetic BWR>BWC
- Heading (true) HDT>VHW (true)>HDG>HDM>VHW (magnetic)
- Heading (magnetic) HDG> HDM>VHW (magnetic)>HDT> VHW (true)
- Magnetic variation HDG>RMC
- Cross-track error XTE>RMB
- Depth DPT>DBT
- Temperature MTW
- Wind (true) MWV>VWT
- Wind (relative) MWV>VWR
- Time: ZDA

3. HOW TO SET THE EQUIPMENT

3.1 How to Set the Language

At the first power application after installation, select a language as follows.

1. Press  /BRILL key to turn on the power.

"Now Initializing" appears and after a while the window below appears.

| Language | English |
|----------|------------|
| Langue | Français |
| Idioma | Español |
| Sprache | Deutsch |
| Lingua | Italiano |
| Idioma | Português |
| Sprog | Dansk |
| Språk | Svenska |
| Språk | Norsk |
| Kieli | Suomi |
| Γλώσσα | Ελληνικά |
| 语言 | 中文 |
| 言語 | 日本語 |
| ភាសា | ភាសា ខ្មែរ |
| 언어 | 한국어 |
| Язык | Русский |

2. Use the cursor pad to select a language required and press the **ENTER** key.

The window shown below appears.

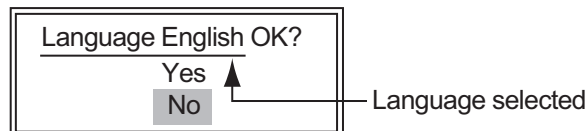

3. Select [Yes] and press the **ENTER** key.

3.2 How to Set the Purpose

Set the purpose of the radar.

1. Press the **MENU** key. The main menu appears on the screen.
2. Press ▼ or ▲ on the cursor pad to select [Factory]. The factory menu title bar appears in gray on the right of the screen.
3. While you press the **CANCEL/HL OFF** key, press the **MENU** key five times to activate the Factory menu.

| Menu | Factory |
|--------------|--|
| Target | Language : English |
| ARPA | Purpose : Sea |
| AIS | Model : 1835 RTR-057A* |
| GPS | |
| ▼ System | |
| Initial | |
| Tests | |
| Sector Blank | |
| Units | |
| Installation | |
| Factory | [ENTER]: Enter [CANCEL/HL OFF]: Back [MENU]: Exit |

*: The model name depends on your radar model.
Do not change the model name.

4. Press the **ENTER** key. The Factory menu becomes active and the cursor moves to the right column.
5. Press ▼ or ▲ to select the Purpose.
6. Press the **ENTER** key to show the setting window.

| |
|---------------|
| River |
| Sea |
| IEC |
| Russian-River |

7. Press ▼ or ▲ to select an option.
8. Press the **ENTER** key to validate the setting.
9. Press the **CANCEL/HL OFF** key to return to the main menu.

3.3 How to Enter the Initial Settings

After you set the purpose of the radar, enter the initial settings as follows.

1. On the main menu, press ▼ or ▲ to select [Installation].

| Menu | Installation |
|--------------------------------------|-----------------------------|
| Target | Input Source : Master |
| ARPA | ARPA QV Select : Off |
| AIS | Demo Mode : Off |
| GPS | Antenna Rotation : Rotate |
| ▼ System | Antenna Height : 15m |
| Initial | Near STC Level : 2 |
| Tests | A/C Auto Adjust : 0 |
| Sector Blank ** | Heading Adjust : 0.0 ° |
| Units | Timing Adjust : 0.000 NM |
| Installation | MBS Adjust* : 0 |
| Factory | Video Init Adjust* : 6 |
| | ARPA Adjust SP* : 2 |
| | ARPA Adjust MP* : 2 |
| | ARPA Adjust LP* : 2 |
| | Auto Install Setup* |
| | Total On Time* : 000000.5 h |
| | Total TX Time* : 000000.6 h |
| | Memory Clear* |
| [ENTER]: Enter [CANCEL/HL OFF]: Back | |
| [MENU]: Exit | |

* : Displayed when scrolled.

** : Set the [Sector Blank] to [Off] in order to execute [Auto Installation Setup] in the [Installation] menu.

2. Press the **ENTER** key. The Installation menu becomes active and the cursor moves to the right column.
3. Press ▼ or ▲ to select an item from the [Installation] menu.
4. Press the **ENTER** key to show the setting window.
5. Press ▼ or ▲ to select an option.
6. Press the **ENTER** key to validate the setting.
7. Press the **MENU** key to close the main menu.

Basic Settings

Input Source: Select the input source from [Master] and [Slave]. The default setting is [Master].

Master: A display unit operates as the main radar.

Slave: A display unit operates as a remote display. For the remote display, make sure you adjust the [Video Init Adjust] and [Timing Adjust] (page 3-5 and 3-6).

ARPA QV Select: Set to [On] position to display quantized video on the screen. Set to [Off] position for normal use.

Demo Mode: Set to [On] position to activate the demo mode. Set to [Off] position for normal use.

Antenna Rotation: [Rotate] (default setting) transmits the radar pulses with rotating the antenna. [Stop] transmits the radar pulses without rotating the antenna.

Antenna Height: Set the height of the antenna above the water surface. The options are 5, 10, 15, 20, 30, 40 and 50 m. The default setting is 15 m.

Near STC Level: Set the STC curve at near distance. The options are 1, 2, 3 and 4. "4" has the strongest effect.

A/C Auto Adjust: Adjust the performance of the automatic A/C.

Memory Clear: Restore the default settings. [Purpose], [Type] and [Input Source] are not changed. When turning on the power after the memory clear, the language selection window appears. (See page 3-1.)

Heading Adjustment

You have installed the antenna unit so that the unit faces toward the bow. A target at the front of the boat and aligned with the bow must appear on the heading line (zero degrees). If the target does not appear on the heading line, do the procedure shown below to adjust the heading.

1. Set ship heading toward an acceptable target (for example, ship at anchor or buoy) at a range between 0.125 and 0.25 nautical mile.
2. Transmit the radar at the range of 0.25 nautical mile and measure the bearing of that target relative to ship heading with an EBL.
3. Open the Installation menu and select [Heading Adjust].
4. Press the **ENTER** key to show the window for heading adjust.

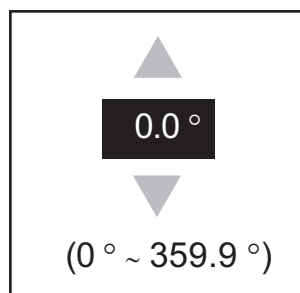

5. Press ▼ or ▲ to set the value measured at the above step 2. Check that the target appears on the heading line.
6. Press the **ENTER** key to complete the setting.

How to automatically set the equipment

The equipment automatically adjusts the tuning, timing and video.

Note: Before you do this procedure, transmit the radar more than 10 minutes on a long range and check that [Sector Blank] is [OFF].

1. Transmit on the maximum range.
2. Select [Auto Install Setup] from the installation menu and press the **ENTER** key.
3. Press **▲** on the cursor pad to select [Yes], then press the **ENTER** key.

The tuning adjustment begins automatically, and the indication "Tuning adjusting" appears during tuning adjustment. After the tuning adjustment is completed, the timing and video are adjusted in that order. The indications "Timing adjusting" and "Video adjusting" appear during those adjustments. After all adjustments are completed, the window disappears.

If the result for any item is not best for your conditions, manually adjust the item according to the procedure in this section.

Manual Timing Adjustment

This adjustment gives correct radar performance on short ranges. The radar measures the time required for a transmitted echo to go to the target and return to the source. The received echo appears on the display according to the measured time. The sweep must start from the center of the display.

A trigger pulse created in the display unit goes to the antenna unit through the signal cable to activate the transmitter (magnetron). The time taken by the signal to move to the antenna unit changes, according to the length of the signal cable. During this period, the display unit must wait before the radar starts the sweep. When the display unit is not adjusted correctly, the echoes from a straight object will not appear as a straight line. The target appears "pushed" or "pulled" near the picture center. The range to objects are shown at wrong distances.

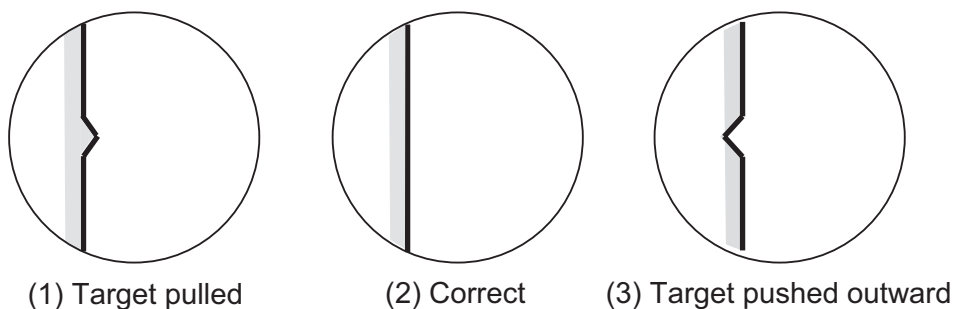

Examples of wrong and correct sweep timings

1. Transmit on the shortest range, then adjust the gain and the A/C SEA.
2. Visibly select a target that creates a straight line (harbor wall, straight piers).
3. Open the Installation menu and select [Timing Adjust].
4. Press the **ENTER** key to show the setting window.
5. Press **▼** or **▲** to make straight the target selected at step 2, then press the **ENTER** key to finish.

Manual MBS Adjustment

Reduce the main bang (black hole), which appears at the display center on short ranges, as follows.

1. Transmit the radar on the shortest range.
2. Open the Installation menu and select [MBS Adjust].
3. Press the **ENTER** key to show the setting window.
4. Press the cursor pad to reduce the main bang (between 0 and 25).
5. Press the **ENTER** key to finish.

Video Initial Adjustment

After you complete the automatic installation setting, tune the video signal if necessary.

1. Transmit the radar and set the radar as follows.
 - Gain : 85 to 90
 - A/C Sea : zero
 - A/C Rain : zero
 - Echo Average : OFF
 - Noise Rejector : OFF
 - Interference Rejector : 2
2. Open the Installation menu and select [Video Init Adjust].
3. Press the **ENTER** key to show the setting window.
4. Press the cursor pad to show some white noise on the display. The setting range is 0 to 31. A large value increases the gain.
5. Press the **ENTER** key to finish.

Note: If the display unit is used as a remote display, set [Input Source] to [Slave]. Do the [Video Initial Adjust] as shown in the above procedure. The echo presentation on the remote display is like the presentation on the main display.

ARPA Adjustment

During the sea trial, adjust the threshold level of the ARPA for short pulse, middle pulse and long pulse.

- Default setting is 2.
- If the ship echoes are difficult to acquire at the setting 2, set to 1.
- If the ARPA symbol moves to other echo at the setting 2, set to 3.

4. OPTIONAL EQUIPMENT

4.1 ARP Kit ARP-11

The ARP kit provides automatic radar plotter functions to this radar.

Necessary parts

Name: ARP kit

Type: ARP-11

Code no.: 008-523-050

For details, see the packing list attached to the kit.

1. Unscrew 12 screws and five connector nuts at the rear of the display unit.



Do not remove this connector nut.

Rear panel of Display unit

2. Lift the cover slowly and open it as shown below.

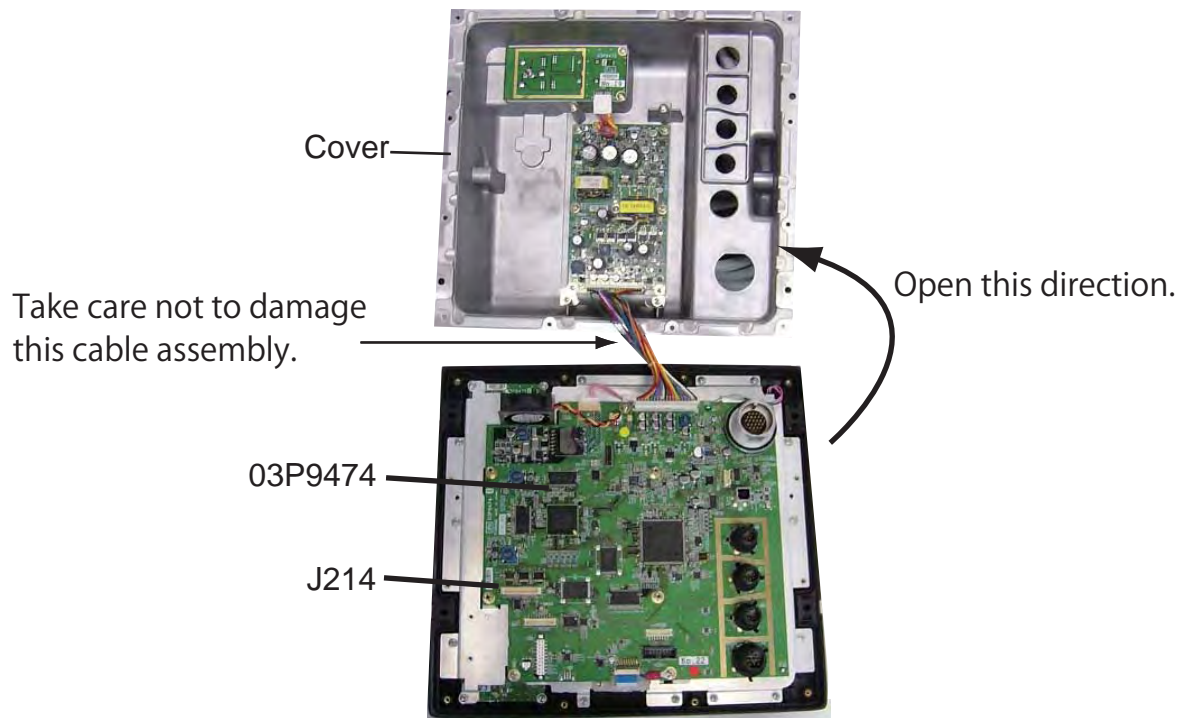

3. Mate P107 on the ARP board to J214 on the 03P9474 board and fasten the ARP board with four screws.

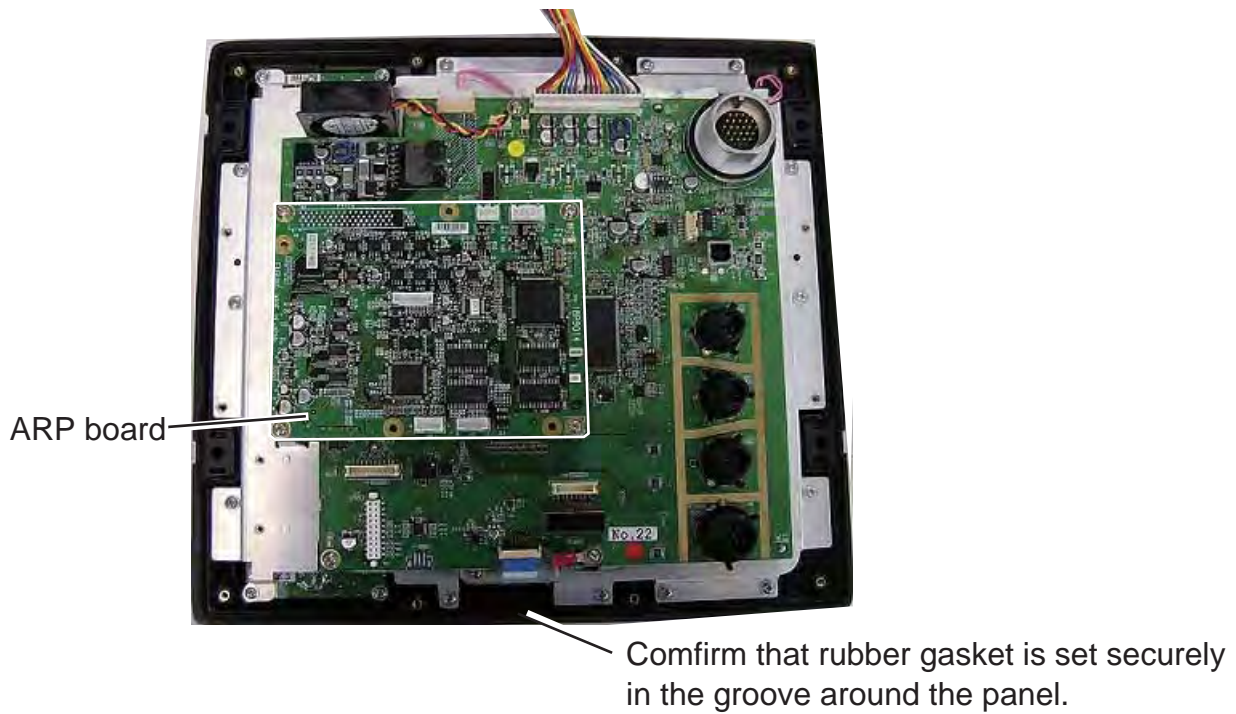

4. Reassemble the display unit.

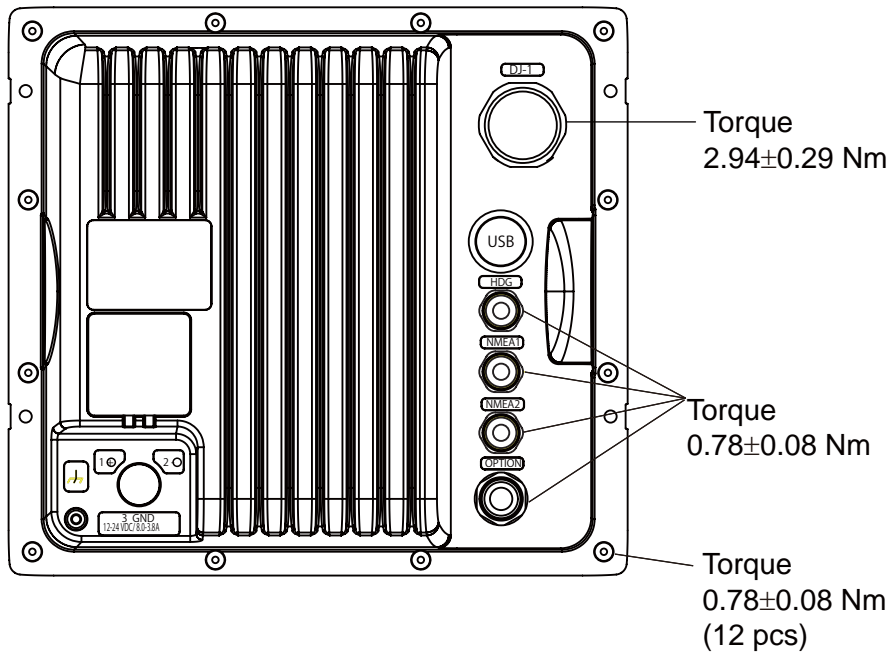

4.2 Connection of Buzzer and/or Remote Display

You need the cables shown below to connect the optional external buzzer and remote display.

- Two-way cable MJ-A10SPFW0001+R
- MJ-A7SPF0007-050C
- MJ-B24LPF0010-xxx+R (xxx: 100, 200 or 300)

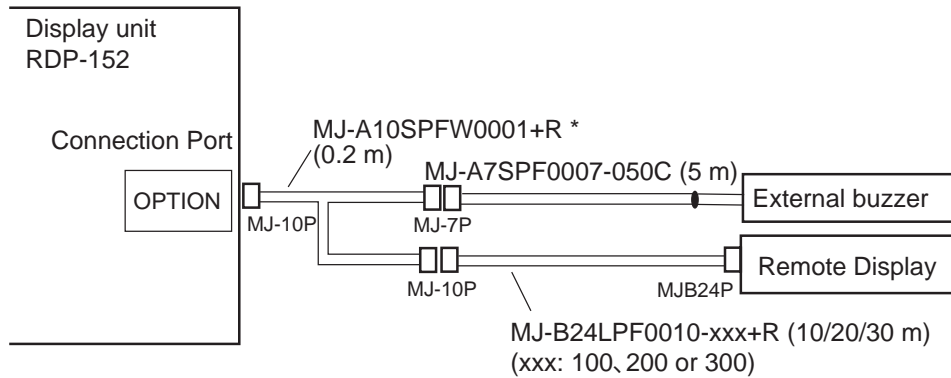

*: This cable is not required to connect the remote display only.

External buzzer

When a target enters (exists) in the guard zone, the optional external buzzer gives a loud alarm.

Type:OP03-21

Code no.:000-030-097

| | Name | Type | Code No. | Qty | Comment |
|---|-------------------|--------------|----------------|-----|---------------------------|
| 1 | Buzzer | PKB42SWH2940 | 000-153-221-10 | 1 | One NH connector attached |
| 2 | Cable tie | CV-70N | 000-162-185-10 | 4 | |
| 3 | Heat-shrink- tube | 3x0.25 BLK | 000-165-283-10 | 1 | 40 mm |
| 4 | Double-sided Tape | 9760 | 000-800-851-00 | 1 | 25 mm x 25 mm |

Attach the two-way cable and MJ-A7SPF0007-050C cable to the OPTION port at the rear of the display unit. See the above figure.

1. Cut the NH connector at the end of the external buzzer cable to an acceptable length.
2. Solder the external buzzer cable to the MJ-A7SPF0007-050C cable as shown below. Before you solder the cores, cut the heat-shrink-tube in half and set the tubes to the cores of the cable. Solder the cores, then set the tubes on the soldered point.

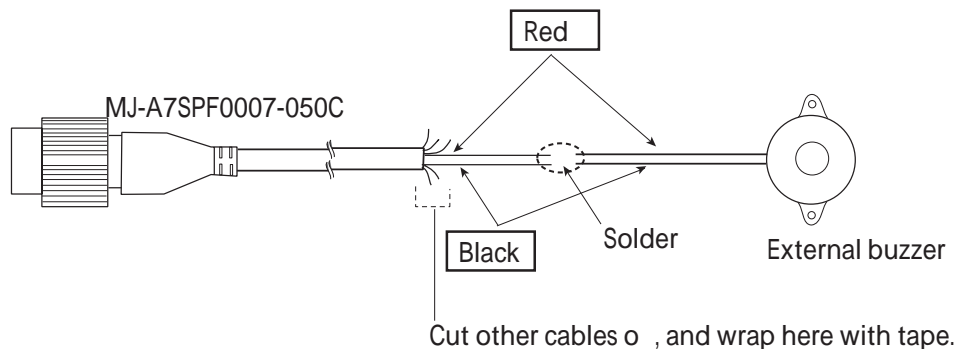





3. Fasten the buzzer with the double-sided tape or two self-tapping screws (3x15 or 3x20, local supply).

PACKING LIST RDP-152-1835-E, RDP-152-1935-E, RDP-152-1945-E

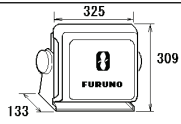
03HD-X-9852-2

1/1

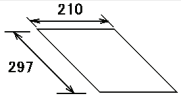
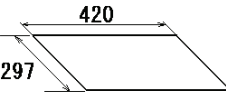
| NAME | OUTLINE | DESCRIPTION/CODE No. | Q' TY |
|-------------------------------|---|----------------------|-------|
| UNIT | | | |
| DISPLAY UNIT |  | RDP-152-1835/19**-E | 1 |
| | | 000-014-616-00 ** | |
| SPARE PARTS | | | |
| SPARE PARTS |  | SP03-12200 | 1 |
| | | 000-086-965-00 | |
| ACCESSORIES | | | |
| ACCESSORIES |  | FP03-11601 | 1 |
| | | 001-058-470-00 | |
| INSTALLATION MATERIALS | | CP03-32900 | |
| CABLE ASSY. |  | MJ-A3SPF0017-050ZC | 1 |
| | | 000-157-995-10 | |
| INSTALLATION MATERIALS |  | CP03-32901 | 1 |
| | | 001-058-460-00 | |
| DOCUMENT | | | |
| NOTICE FOR FUSE REPLACEMENT |  | J39-60060-* | 1 |
| | | 000-172-409-1* | |
| FLUSH MOUNTING TEMPLATE |  | C32-00802 | 1 |
| | | 000-172-410-1* | |

CODE NUMBER ENDING WITH “**” INDICATES THE CODE NUMBER OF REPRESENTATIVE MATERIAL.

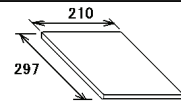
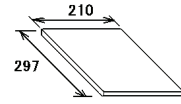
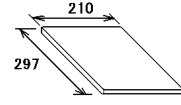
| NAME | OUTLINE | DESCRIPTION/CODE No. | Q' TY |
|---------------------|---|----------------------|-------|
| OPERATOR'S MANUAL |  | OME-35790-* | 1 |
| | | 000-172-398-1* | |
| OPERATOR'S GUIDE |  | MLG-35790-* | 1 |
| | | 000-172-400-1* | |
| INSTALLATION MANUAL |  | IME-35790-* | 1 |
| | | 000-172-402-1* | |

(DIMENSIONS IN DRAWING FOR REFERENCE ONLY.)



TWO TYPES AND CODES MAY BE LISTED FOR AN ITEM. THE LOWER PRODUCT MAY BE SHIPPED IN PLACE OF THE UPPER PRODUCT. QUALITY IS THE SAME.

PACKING LIST

19AL-X-9852 -6 1/1

RSB-0071-057

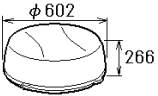
A-2

| NAME | OUTLINE | DESCRIPTION/CODE No. | Q'TY |
|--|---|----------------------|------|
| UNIT | | | |
| ANTENNA UNIT |  | RSB-0071-057 | 1 |
| | | 000-086-830-00 | |
| ANTENNA UNIT INSTALLATION MATERIALS | | | |
| INSTALLATION MATERIALS |  | CP03-16901 | 1 |
| | | 008-478-750-00 | |

CODE NUMBER ENDING WITH "**" INDICATES THE CODE NUMBER OF REPRESENTATIVE MATERIAL.

TWO TYPES AND CODES MAY BE LISTED FOR AN ITEM. THE LOWER PRODUCT MAY BE SHIPPED IN PLACE OF THE UPPER PRODUCT. QUALITY IS THE SAME.

(DIMENSIONS IN DRAWING FOR REFERENCE ONLY.)







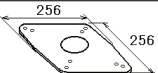
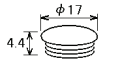

JP

C3502-Z02-G

A-3

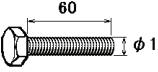
FURUNO

| | | |
|----------|----------------|-----------------|
| CODE NO. | 008-503-360-00 | 03FR-X-9401 -15 |
| TYPE | CP03-18401 | 1/2 |

| ANTENNA INSTALLATION MATERIALS | | | | | |
|---------------------------------------|----------------------------|---|-------------------------|-------|---------|
| NO. | NAME | OUTLINE | DESCRIPTIONS | Q' TY | REMARKS |
| 1 | SEAL WASHER |  | 03-001-3002-0 ROHS | 4 | |
| | | | CODE NO. 300-130-020-10 | | |
| 2 | CORROSION-PROOF RUBBER MAT |  | 03-142-3001-0 ROHS | 1 | |
| | | | CODE NO. 100-275-580-10 | | |
| 3 | KNOB CAP |  | 040-4010 | 4 | |
| | | | CODE NO. 000-164-929-10 | | |
| 4 | SPRING WASHER |  | M12 SUS304 | 4 | |
| | | | CODE NO. 000-167-397-10 | | |
| 5 | FLAT WASHER |  | M12 SUS304 | 4 | |
| | | | CODE NO. 000-167-446-10 | | |
| 6 | HEXAGONAL NUT |  | M12 SUS304 | 4 | |
| | | | CODE NO. 000-167-491-10 | | |
| 7 | HEXAGON HEAD SCREW |  | M12X60 SUS304 | 4 | |
| | | | CODE NO. 000-162-813-10 | | |
| 8 | SPRING WASHER |  | M6 SUS304 | 1 | |
| | | | CODE NO. 000-158-855-10 | | |
| 9 | FLAT WASHER |  | M6 SUS304 | 3 | |
| | | | CODE NO. 000-158-854-10 | | |
| 10 | HEXAGONAL NUT |  | M6 SUS304 | 1 | |
| | | | CODE NO. 000-158-856-10 | | |

TWO TYPES AND CODES MAY BE LISTED. THE BOTTOM PRODUCT MAY BE SHIPPED IN PLACE OF THE TOP PRODUCT. QUALITY IS THE SAME.

FURUNO ELECTRIC CO., LTD.

JP

FURUNO

| | | |
|----------|----------------|-----------------|
| CODE NO. | 008-503-360-00 | 03FR-X-9401 -15 |
| TYPE | CP03-18401 | 2/2 |

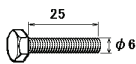
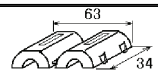
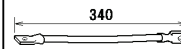
| ANTENNA INSTALLATION MATERIALS | | | | | |
|--------------------------------|---------------------|---|-------------------------|------|---------|
| NO. | NAME | OUTLINE | DESCRIPTIONS | Q'TY | REMARKS |
| 11 | HEXAGONAL HEAD BOLT |  | M6X25 SUS304 | 1 | |
| | | | CODE NO. 000-162-871-10 | | |
| 12 | EMI CORE |  | RFC-13 | 3 | |
| | | | CODE NO. 000-141-084-11 | | |
| 13 | CABLE ASSY. |  | RW-4747 | 1 | |
| | | | CODE NO. 000-566-000-12 | | |





TWO TYPES AND CODES MAY BE LISTED. THE BOTTOM PRODUCT MAY BE SHIPPED IN PLACE OF THE TOP PRODUCT. QUALITY IS THE SAME.

FURUNO ELECTRIC CO., LTD.

JP
C3459-M02-Q (2)

FURUNO

| | | |
|----------|--|----------------|
| CODE NO. | | 03HD-X-9402 -0 |
| TYPE | | 1/1 |

| INSTALLATION MATERIALS | | | | | |
|------------------------|-------------|---|-------------------------|------|--------------|
| MODEL 1835 | | | | | |
| NO. | NAME | OUTLINE | DESCRIPTIONS | Q'TY | 用途/備考 |
| 1 | CABLE ASSY. |  | MJ-B24LPF0002-100+R | 1 | TO BE SELECT |
| | | | CODE NO. 000-138-972-12 | | |
| 2 | CABLE ASSY. |  | MJ-B24LPF0002-150+R | 1 | TO BE SELECT |
| | | | CODE NO. 000-138-970-12 | | |
| 3 | CABLE ASSY. |  | MJ-B24LPF0002-200+R | 1 | TO BE SELECT |
| | | | CODE NO. 000-138-974-12 | | |
| 4 | CABLE ASSY. |  | MJ-B24LPF0002-300+R | 1 | TO BE SELECT |
| | | | CODE NO. 000-138-973-12 | | |

TWO TYPES AND CODES MAY BE LISTED FOR AN ITEM. THE LOWER PRODUCT MAY BE SHIPPED IN PLACE OF THE UPPER PRODUCT. QUALITY IS THE SAME.
(DIMENSIONS IN DRAWING FOR REFERENCE ONLY.)





☆

FURUNO ELECTRIC CO., LTD.

C3579-M02-A

FURUNO

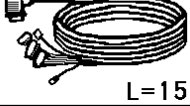
| | | |
|----------|--|----------------|
| CODE NO. | | 03HD-X-9403 -0 |
| TYPE | | 1/1 |

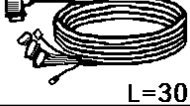
| INSTALLATION MATERIALS | | MODEL 1935/1945/1937 | | | |
|------------------------|-------------|--|-------------------------|-------|--------------|
| NO. | NAME | OUTLINE | DESCRIPTIONS | Q' TY | REMARKS |
| 1 | CABLE ASSY. |  <p>L=5M</p> | MJ-B24LPF0005-050+R | 1 | TO BE SELECT |
| | | | CODE NO. 000-143-736-12 | | |
| 2 | CABLE ASSY. |  <p>L=10M</p> | MJ-B24LPF0005-100+R | 1 | TO BE SELECT |
| | | | CODE NO. 000-140-434-12 | | |
| 3 | CABLE ASSY. |  <p>L=15M</p> | MJ-B24LPF0005-150+R | 1 | TO BE SELECT |
| | | | CODE NO. 000-140-435-12 | | |
| 4 | CABLE ASSY. |  <p>L=20M</p> | MJ-B24LPF0005-200+R | 1 | TO BE SELECT |
| | | | CODE NO. 000-140-436-12 | | |
| 5 | CABLE ASSY. |  <p>L=30M</p> | MJ-B24LPF0005-300+R | 1 | TO BE SELECT |
| | | | CODE NO. 000-140-437-12 | | |

TWO TYPES AND CODES MAY BE LISTED FOR AN ITEM. THE LOWER PRODUCT MAY BE SHIPPED IN PLACE OF THE UPPER PRODUCT. QUALITY IS THE SAME.
 (DIMENSIONS IN DRAWING FOR REFERENCE ONLY.)

☆

TABLE 1

| (mm) dimensions | (mm) TOLERANCE |
|---------------------|-------------------|
| $0 < L \leq 50$ | |
| $50 < L \leq 100$ | ± 2.5 |
| $100 < L \leq 500$ | ± 3 |
| $500 < L \leq 1000$ | ± 4 |

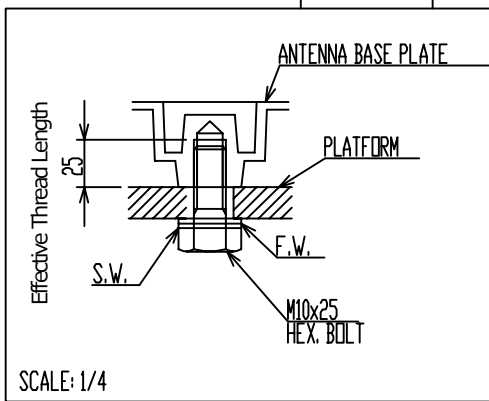
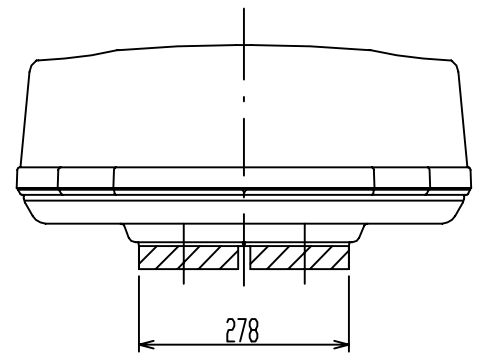
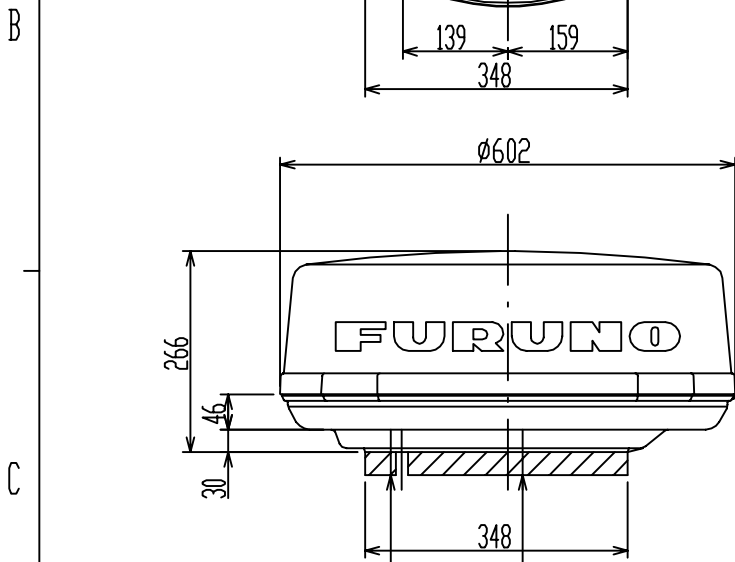
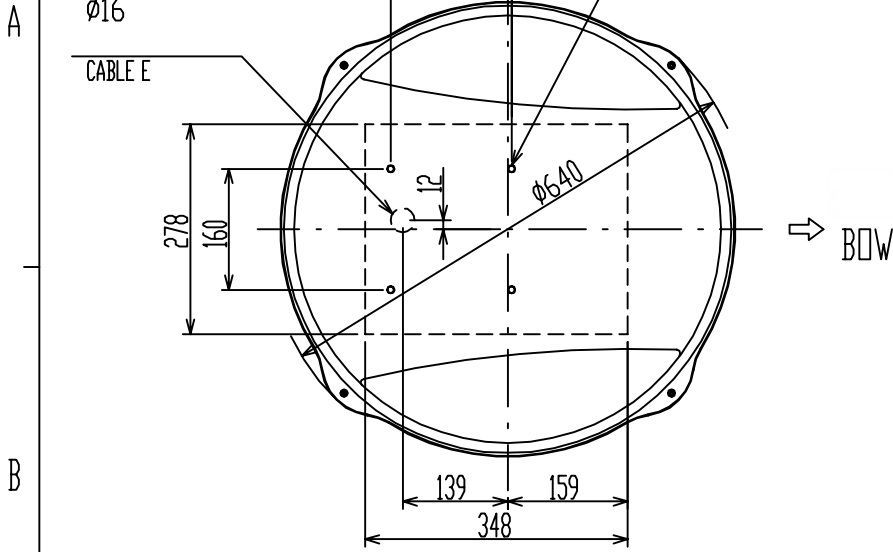

NOTE
TABLE 1 INDICATES TOLERANCE OF DIMENSIONS WHICH IS NOT SPECIFIED.

| | | | |
|----------|---------------------------------------|-------|---------------------------------|
| DRAWN | MODEL 1734C MODEL 1834C/1834C(-BB) | TITLE | RSB-0071 |
| CHECKED | MODEL 1833/1833C MODEL 1732/1732C | | |
| APPROVED | RS-1000 MODEL 1832 | | |
| SCALE | 1/10 | MASS | 8 $\pm 10\%$ kg |
| DWG.No. | C3441-G01-G | | 03-136-6001-G2 |
| | | NAME | ANTENNA UNIT OUTLINE DRAWING |

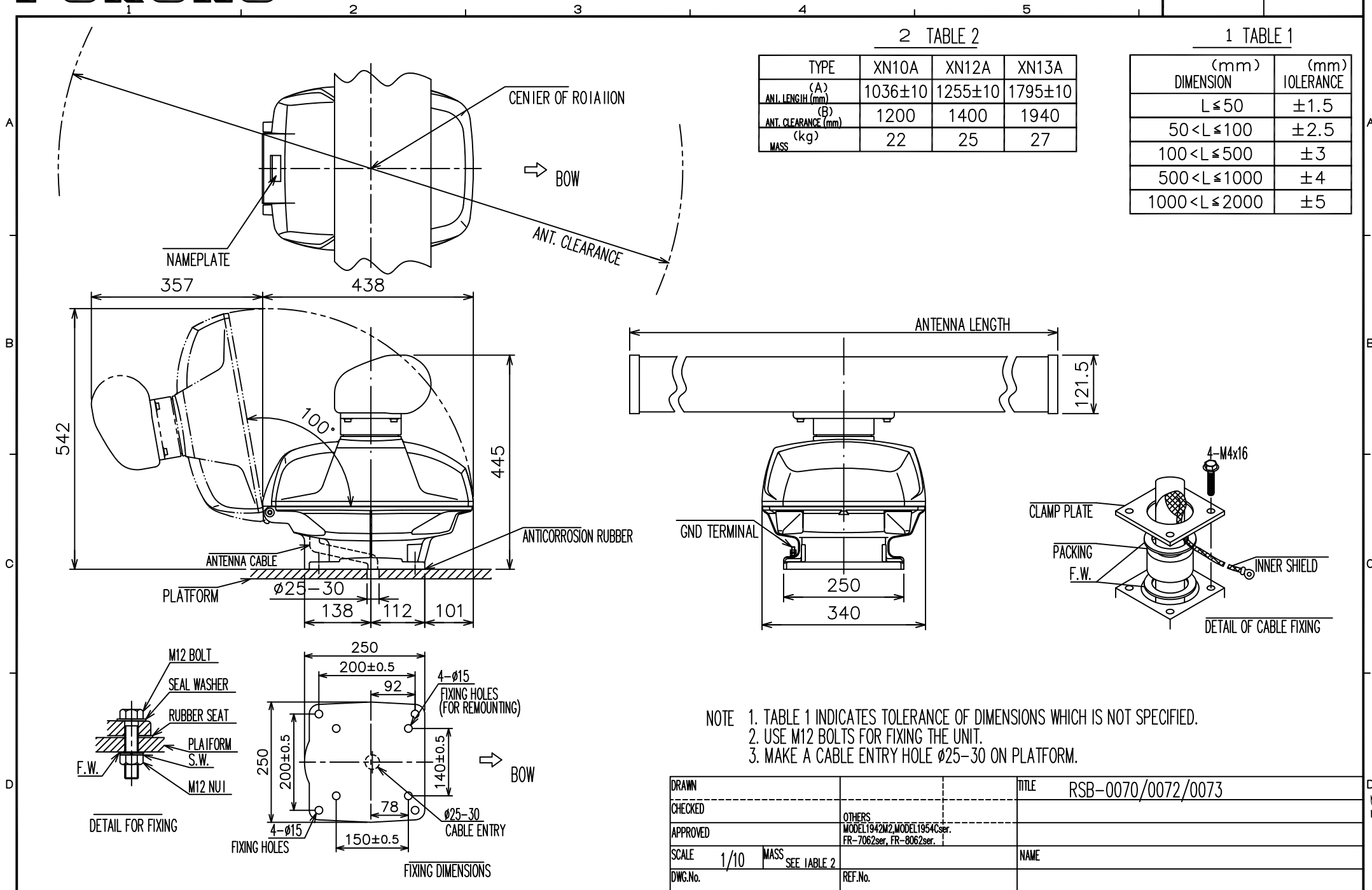

2 TABLE 2

| TYPE | XN10A | XN12A | XN13A |
|----------------------------|---------|---------|---------|
| ANT. LENGTH (A) (mm) | 1036±10 | 1255±10 | 1795±10 |
| ANT. CLEARANCE (B) (mm) | 1200 | 1400 | 1940 |
| MASS (kg) | 22 | 25 | 27 |

1 TABLE 1

| DIMENSION (mm) | TOLERANCE (mm) |
|----------------------|----------------|
| $L \leq 50$ | ±1.5 |
| $50 < L \leq 100$ | ±2.5 |
| $100 < L \leq 500$ | ±3 |
| $500 < L \leq 1000$ | ±4 |
| $1000 < L \leq 2000$ | ±5 |

NOTE 1. TABLE 1 INDICATES TOLERANCE OF DIMENSIONS WHICH IS NOT SPECIFIED.
 2. USE M12 BOLTS FOR FIXING THE UNIT.
 3. MAKE A CABLE ENTRY HOLE $\phi 25-30$ ON PLATFORM.

| | | | |
|----------|------|--------------------------------|--------------------|
| DRAWN | | TITLE | RSB-0070/0072/0073 |
| CHECKED | | OTHERS | |
| APPROVED | | MODEL 1942M2, MODEL 1954C ser. | |
| SCALE | 1/10 | FR-7062 ser., FR-8062 ser. | |
| DWG.No. | | REF.No. | |
| | | NAME | |

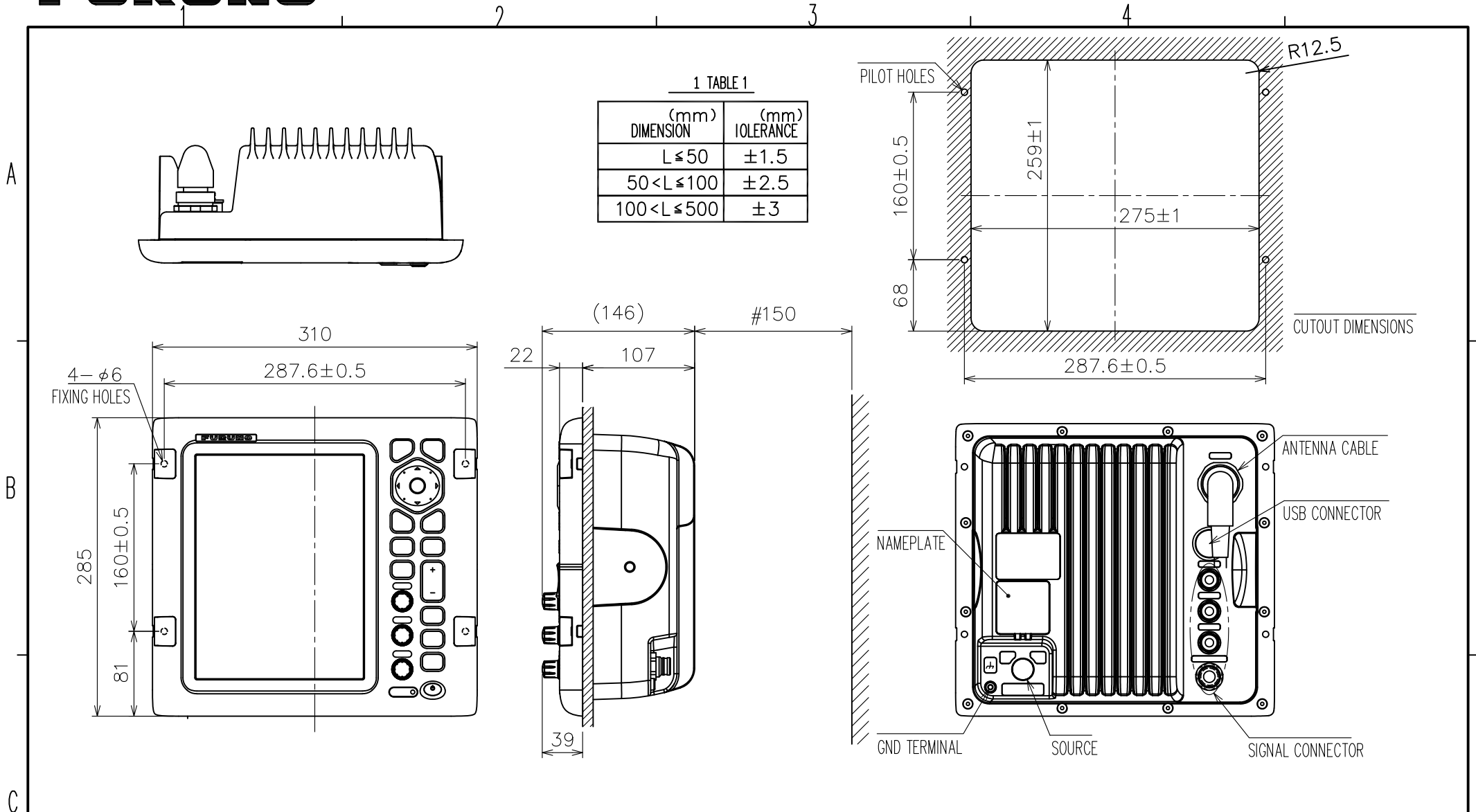

1 TABLE 1

| DIMENSION (mm) | TOLERANCE (mm) |
|--------------------|----------------|
| $L \leq 50$ | ± 1.5 |
| $50 < L \leq 100$ | ± 2.5 |
| $100 < L \leq 500$ | ± 3 |

- NOTE
- TABLE 1 INDICATES TOLERANCE OF DIMENSIONS WHICH IS NOT SPECIFIED.
 - #: MINIMUM SERVICE CLEARANCE.
 - USE TAPPING SCREWS $\phi 5 \times 20$ FOR FIXING THE UNIT.
 - KEEP SUFFICIENT CABLE LENGTH BEHIND THE UNIT FOR MAINTENANCE.

| | | | | | |
|---------------------|-----------------------|------------------------------------|--|---------------------------------|--|
| DRAWN | | | | TITLE RDP-152 | |
| CHECKED | | | | | |
| APPROVED | | MODEL T945 MODEL 1835/1935/1937 | | | |
| SCALE 1/5 | MASS 4.3 ±10% | MASS W/O CABLE. | | NAME DISPLAY UNIT (FLUSH MOUNT) | |
| DWG.No. C3579-G01-B | REF.No. 03-176-100G-1 | | | OUTLINE DRAWING | |

FURUNO

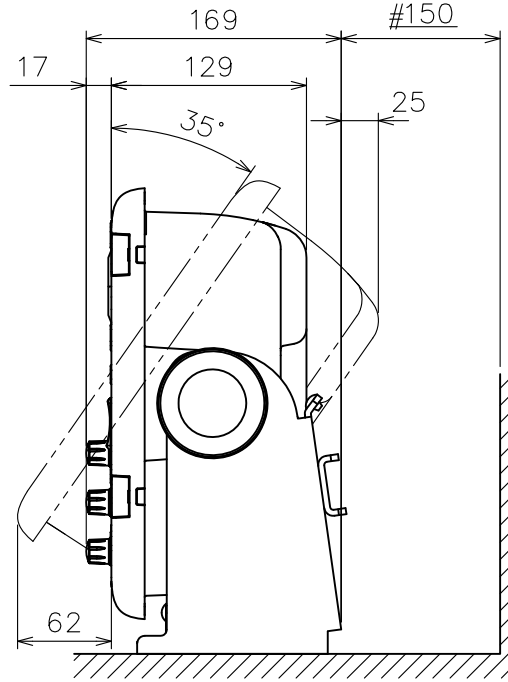
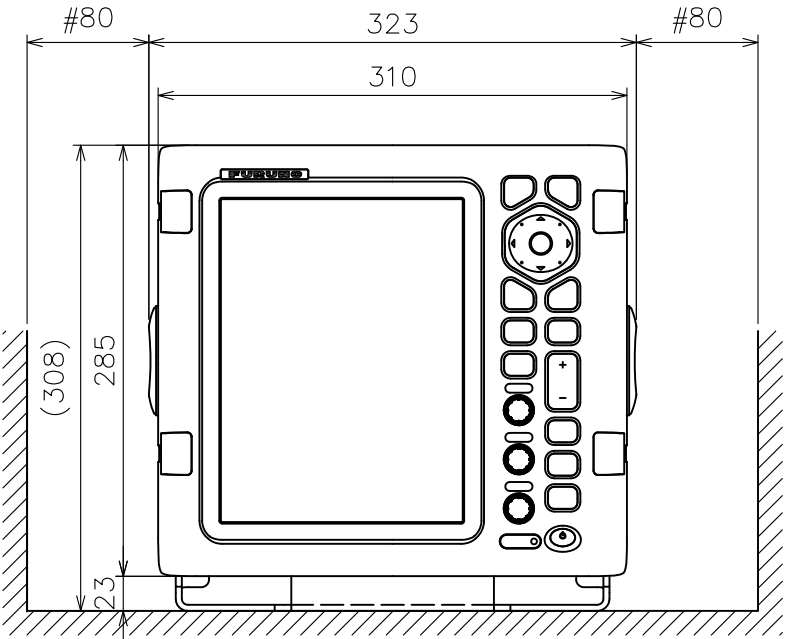
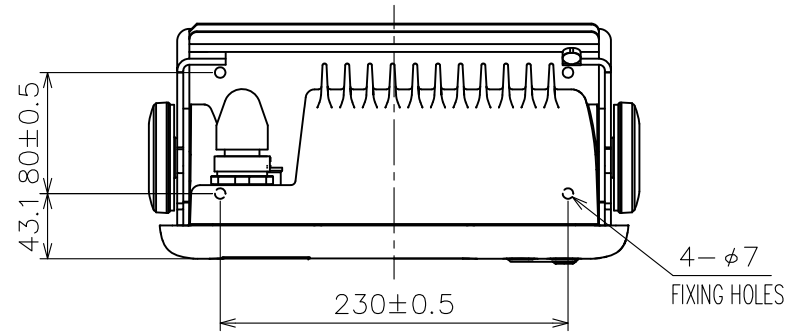

1 TABLE 1

| DIMENSION (mm) | TOLERANCE (mm) |
|--------------------|----------------|
| $L \leq 50$ | ± 1.5 |
| $50 < L \leq 100$ | ± 2.5 |
| $100 < L \leq 500$ | ± 3 |

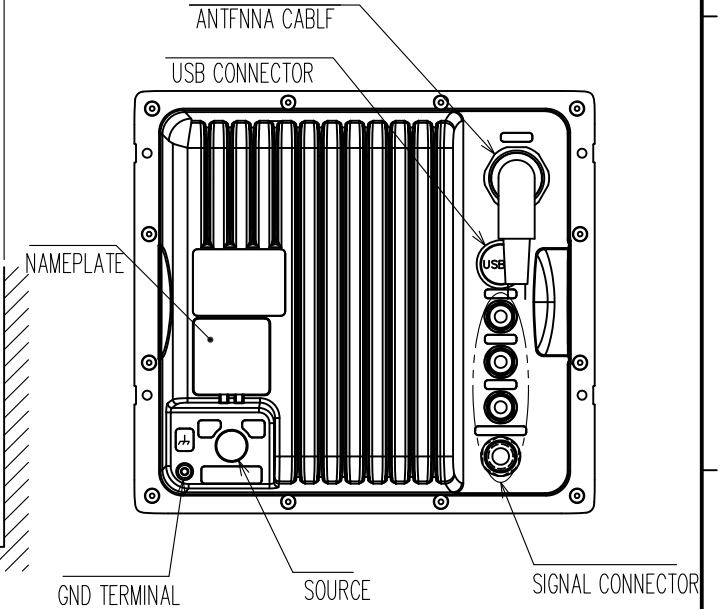

NOTE

- TABLE 1 INDICATES TOLERANCE OF DIMENSIONS WHICH IS NOT SPECIFIED.
- #: MINIMUM SERVICE CLEARANCE.
- USE TAPPING SCREWS $\phi 5 \times 20$ FOR FIXING THE UNIT.
- KEEP SUFFICIENT CABLE LENGTH BEHIND THE UNIT FOR MAINTENANCE.

| | | | | | |
|----------|-------------|------------------------------------|---------------|------------------|------------------------------------|
| DRAWN | | | | TITLE RDP-152 | |
| CHECKED | | | | | |
| APPROVED | | MODEL T945 MODEL 1835/1935/1937 | | | |
| SCALE | 1/5 | MASS | 5.4 | $\pm 10\%$ kg | NAME DISPLAY UNIT (TABLETOP MOUNT) |
| DWG.No. | C3579-G02-B | REF.No. | 03-176-110G-2 | OUTLINE DRAWING | |

FURUNO ELECTRIC CO., LTD.

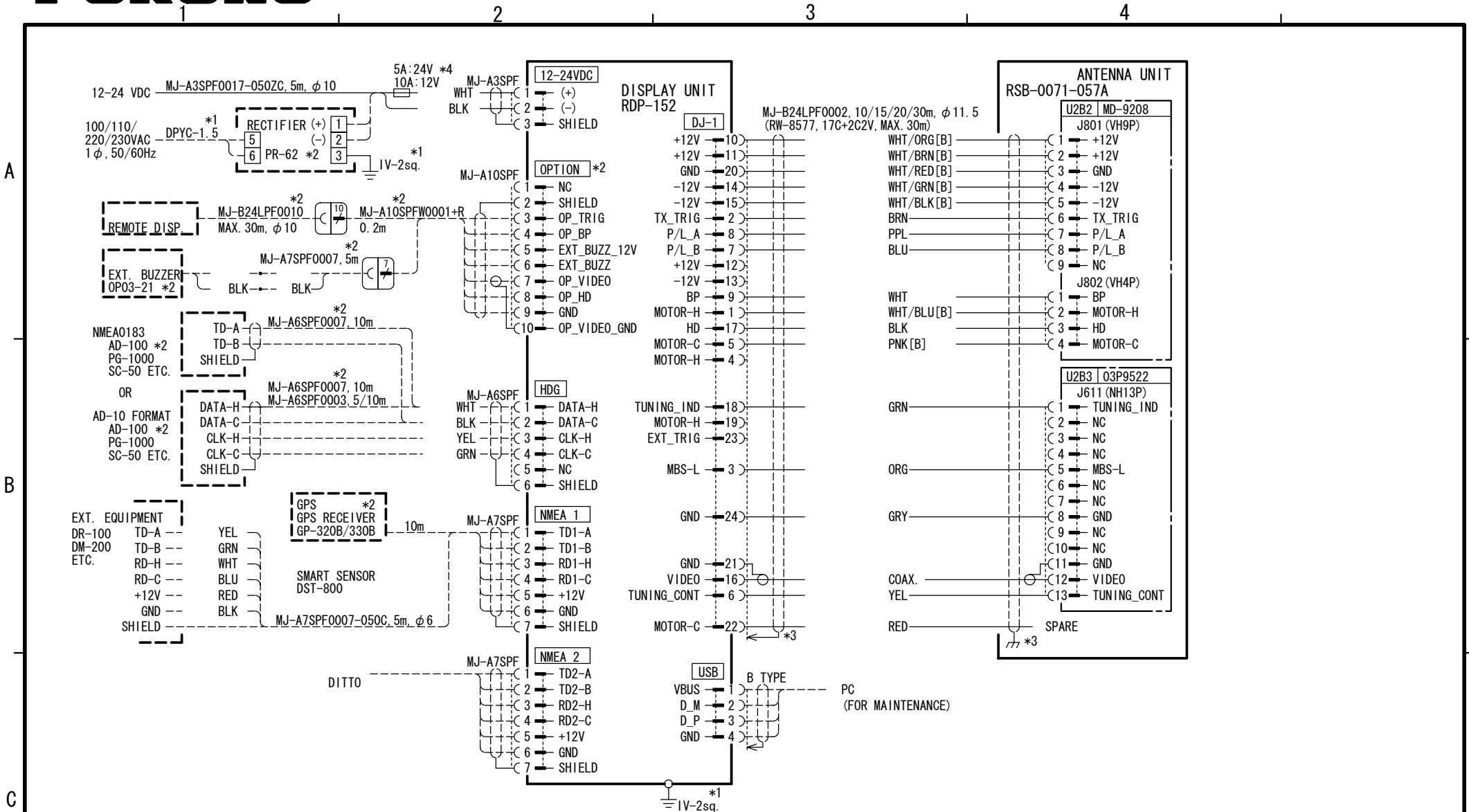

NOTE
 *1: SHIPYARD SUPPLY.
 *2: OPTION.
 *3: SHIELD SHOULD BE GROUNDED EFFECTIVELY AT BOTH END.
 *4: DEFAULT: 10A. REPLACE FUSE TO 5A FOR 24V USE.

| | | | |
|--------------|---------------|-------------------------|--|
| DRAWN | | TITLE | |
| CHECKED | | MODEL 1835 | |
| APPROVED | | | |
| SCALE | MASS | NAME | |
| | kg | MARINE RADAR | |
| DWG. No. | REF. No. | INTERCONNECTION DIAGRAM | |
| C3579-C01- D | 03-176-6001-0 | | |

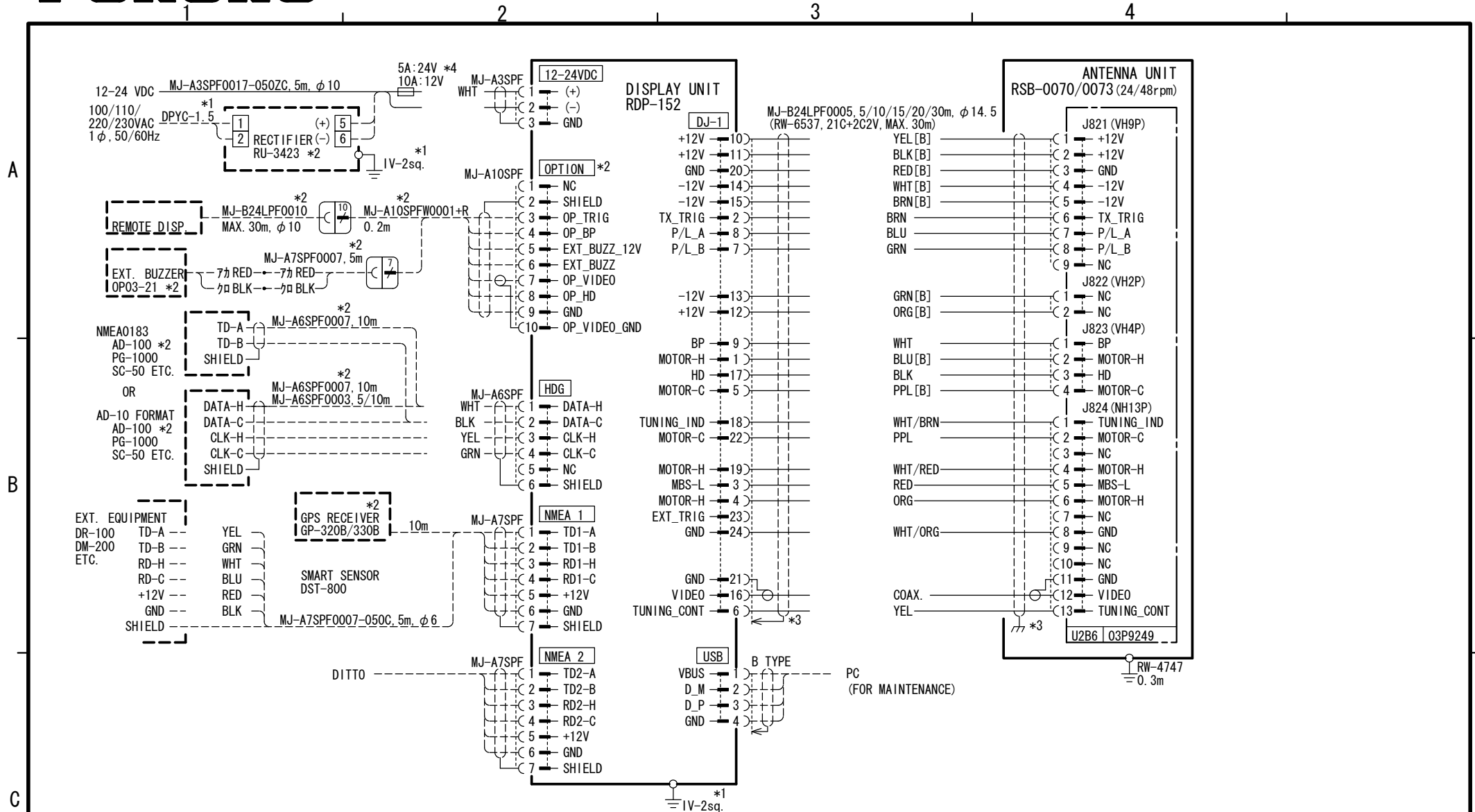

NOTE

- *1: SHIPYARD SUPPLY.
- *2: OPTION.
- *3: SHIELD SHOULD BE GROUNDED EFFECTIVELY AT BOTH END.
- *4: DEFAULT: 10A. REPLACE FUSE TO 5A FOR 24V USE.

| | | | |
|----------|-------------|-------------------------|---------------|
| DRAWN | | TITLE | |
| CHECKED | | MODEL 1935/1937/1945 | |
| APPROVED | | | |
| SCALE | MASS | NAME | MARINE RADAR |
| DWG. No. | C3580-C01-C | REF. No. | 03-176-6002-0 |
| | | INTERCONNECTION DIAGRAM | |