

FURUNO

New • TRANSOM MOUNT • Depth • Speed • Temperature

P66 with Noise Suppression System

50 kHz, 120 kHz, 200 kHz, 235 kHz,
50/200 kHz Dual Frequency

U.S. Patent No. 4,644,787
U.S. Patent No. 5,606,253
U.S. Patent No. 5,719,824

Features Airmar's patented Noise Suppression System

Best performing transom mount
Streamlined rounded nose provides excellent echosounding at high boat speed
Unique bracket design allows transducer removal for storage and transport

Specifications

- Hydrodynamic shape provides vertical sound beam orientation on hull deadrise angles up to 30°
- Reversible wedge allows mounting to transom angles from 2° to 22°
- Integral release bracket protects against impact damage, mounts with 3 screws, and provides 12 mm (1/2") of vertical adjustment
- Chemical and impact resistant plastic housing
- Designed to meet CE requirements
- Shielded piezoceramic element for noise free echosounder display
- Paddlewheel assembly easily removed for inspection, cleaning, and replacement
- Unitary bearings inside paddlewheel hub assure exact alignment and minimal rotational friction
- Standard cable length: 7.6 m (25')
- Weight: 0.5 kg (1.1 lb.)

Speed Sensor Specifications

- Linearity: Refer to *Airmar Technical Data Catalog*
- Standard pulse rate: 26,000 pulses per nautical mile (7.25 Hz per knot)

Options

- Speed and/or temperature sensor
- Waterproof molded connector

Applications

- Small, general purpose echosounders/fishfinders
- Outboard, inboard/outboard or jet boats
- Fiberglass, aluminum, wood or inflatable hulls

Accessories and Replacement Parts

- Paddlewheel kit# 33-346-01

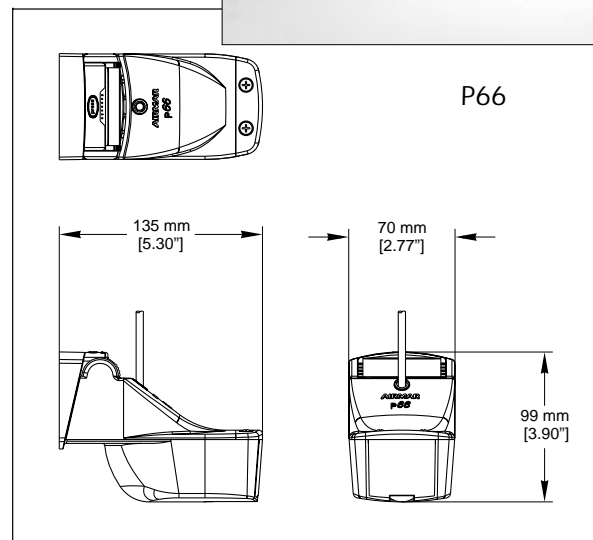

PERFORMANCE DATA

Frequency ¹ – Airmar Piezoceramic Designator ²	50 kHz – C	120 kHz – C	200 kHz – G	235kHz – D	50/200 kHz – A	
Element Material ³ /Diameter (mm)	PZT/L/51	PZT/51	BT/51	BT/ 51	PZT/ 44	
Beam Width at –3 dB	44°	13°	8°	7°	45°	11°
Q (fr/Δ f @ –3 dB) ⁴	15	16	34	16	24	30
Rated RMS Power (W)	600	600	600	600	600	600
Voltage Responses: Transmit/Receive ⁵ (dB)	156/–176	165/–176	167/–183	169/–185	153/–173	164/–182
Figure of Merit (Insertion Loss) ⁶ (dB)	–26	–18	–17	–16	–33	–20
Unbalanced Impedance ⁷ : Resistance, Rp (ohm) Capacitance, Cp (pF)	300	1,910	320	370	250	350
	4,970	1,910	2,710	2,440	3,870	1,900
Series Impedance [R – jX] ⁸ (ohm)	250 – j120	190 – j50	150 – j160	130 – j180	230 – j70	210 – j170
Acoustic Window Material	LPU ¹³	LPU ¹³	LPU ¹³	LPU ¹³	LPU ¹³	

Note: See page m 1 for footnotes.