

# FURUNO

## New • THRU-HULL STEM MOUNT • Depth

### B45

120 kHz, 150 kHz, 200 kHz  
50/200 kHz Dual Frequency

Small, low cost bronze housing

Double ended shape of housing deflects aerated water providing clearer echoes

Optional streamlined fairings dramatically improve echosounding above 20 knots and greatly reduce drag

Optional low impact fairings vertically orient sound beam



### Specifications

- Shielded piezoceramic element for noise free echosounder display
- Designed to meet CE requirements
- Installation requires a small 22 mm (7/8") diameter hole
- Standard cable length: 10 m (33')
- Accommodates hull thickness:
  - Min. no fairing: 6 mm (1/4")
  - Max. no fairing: 92 mm (2 5/8")
  - Max. with fairing: 50 mm (2")
- Weight: 1 kg (2.2 lb)

### Options

- Standard fairing #33-351-01
- High speed fairing #33-352-01
- Temperature
- Waterproof molded connector

### Applications

- Planing and displacement hull powerboats
- Cruising sailboats
- For use on fiberglass or wood hulls only

### Notes

- Replaces Airmar model B3

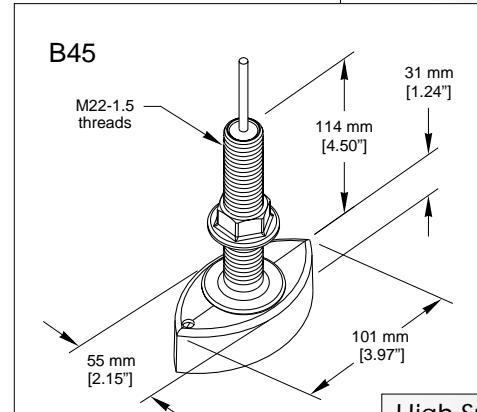

### PERFORMANCE DATA

Frequency <sup>1</sup> – Airmar Piezoceramic Designator <sup>2</sup>	120 kHz – B	150 kHz – A	200 kHz – B	200 kHz – U	50/200 kHz – A	
Element Material <sup>3</sup> /Diameter (mm)	PZT / 37	PZT / 27	BT / 28	BT / 38	PZT / 44	
Beam Width at –3 dB	16°	19°	13°	11°	45°	12°
Q (fr/Δ f @ –3 dB) <sup>4</sup>	21	23	22	22	28	31
Rated RMS Power (W)	300	200	250	375	600	600
Voltage Responses: Transmit/Receive <sup>5</sup> (dB)	161/–181	160/–185	162/–187	164/–185	155/–174	164/–184
Figure of Merit (Insertion Loss) <sup>6</sup> (dB)	–25	–27	–26	–22	–31	–21
Balanced Impedance <sup>7</sup> : Resistance, Rp (ohm) Capacitance, Cp (pF)	260	400	510	510*	190	410
	860	550	560	1,930*	720	720
Series Impedance [R – jX] <sup>8</sup> (ohm)	250 – j40	380 – j80	450 – j160	300 – j250	175 – j40	360 – j130
Acoustic Window Material	Urethane	Urethane	Urethane	Urethane	Urethane	

Note: See page m1 for footnotes.

\*Unbalanced Impedance