

OWNER'S GUIDE & INSTALLATION INSTRUCTIONS

Transom Mount, 1kW, Depth Transducer

with Release Bracket

Models: TM258, TM260, TM270W

WARNING: Always wear safety goggles and a dust mask when installing to avoid personal injury.

CAUTION: Never pull, carry, or hold the transducer by the cable as this may sever internal connections.

CAUTION: Do not strike the transducer to release it. When mounted on the bracket, remove the transducer by removing the locking pin and hinge pin.

CAUTION: Never use solvents. Cleaners, fuel, sealants, paint, and other products may contain strong solvents, such as acetone, which attack many plastics, greatly reducing their strength.

IMPORTANT: Please read the instructions completely before proceeding with the installation. These instructions supersede any other instructions in your instrument manual if they differ.

Applications

- Recommended for outboard and inboard/outboard sport fishing powerboats, 8m (25') and up
- Not recommended for inboard powerboats
- Not recommended for stepped hulls
- Adjusts to transom angles from 3°–21°
- Bracket protects the transducer from frontal impact *only*

Tools & Materials

- Safety goggles
- Dust mask
- Angle finder
- Masking tape (some installations)
- Pencil
- Electric drill
- Drill bits:
 - Bracket holes 5mm, #4, or 7/32"
 - Transom hole (optional) 18mm, 11/16", or 3/4"
 - 21mm or 13/16" (Furuno, Raymarine only)
- Cable clamp holes 3mm or 1/8"
- Marine sealant (suitable for below waterline)
- Socket wrench
- Straight edge
- Small screwdriver
- Grommets (some installations)
- Cable ties
- Water-based anti-fouling paint (**mandatory in salt water**)

Record the information found on the cable tag for future reference.

Part No. _____ Date _____ Frequency _____ kHz

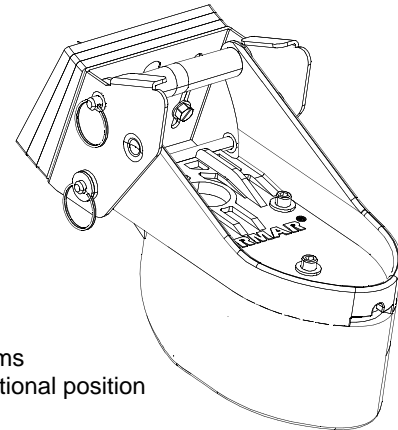

TM260
with shims
in operational position

Mounting Location

General Guidelines

CAUTION: Do not mount the transducer in an area of turbulence or bubbles: near water intake or discharge openings; behind strakes, struts, fittings, or hull irregularities.

CAUTION: Avoid mounting the transducer where the boat may be supported during trailering, launching, hauling, or storage.

- For best performance, the transducer must be in contact with aeration-free and turbulence-free water. To identify an area of smooth water, observe the flow off the transom while the boat is underway.
- Allow headroom space above the bracket for it to release and rotate the transducer upward.
- Mounting on the side of the transom where the propeller blades are moving downward is preferred (see Figure 1).
- Mount the transducer as close to the centerline (keel) of the boat as possible to ensure the transducer's face remains in the water when the boat is turning. However, keep in mind that it should be a minimum of 15 cm (6") beyond the swing radius of the propeller, so the water passing over the transducer does not cause a flow disturbance to the propeller.

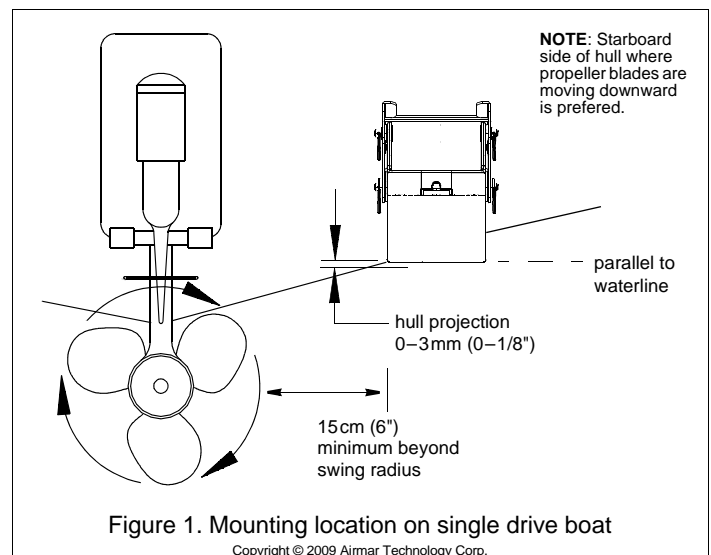

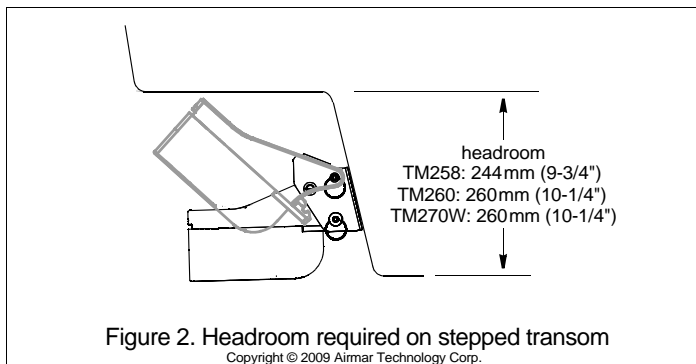

Figure 2. Headroom required on stepped transom
Copyright © 2009 Airmar Technology Corp.

Type of Boat

- **Single drive**—Mount a minimum of 15 cm (6") beyond the swing radius of the propeller (see Figure 1).
- **Twin drive**—Mount between the drives a minimum of 15 cm (6") beyond the swing radius of the propeller.
- **Trim tabs**—Mount inside the trim tab, space permitting.
- **Stepped transom**—Mount the transducer on the lowest step being sure there is enough headroom for the bracket to release (see Figure 2).

Installation

WARNING: Always wear safety goggles and a dust mask.

Assembling the Transducer & Bracket

1. Thread the cable through the large hole in the transducer support (see Figure 3).
2. Fasten the support to the transducer using the three socket-head-cap screws and washers supplied. Tighten the screws with the 3/16" Allen wrench supplied.
3. Attach a safety ring to one end of each pin (see Figure 4).
4. While holding the transducer assembly against the bracket, insert a pin through the *upper* hole in the bracket and the support. Slide the spacer onto the pin and push it through the remaining hole in the support and the bracket. Attach a second safety ring. This pin will function as a hinge when the transducer is released.
5. Slide a washer onto the remaining pin. Push it through the *lower* hole in the bracket, slide it along the channel in the support, and through the second hole in the bracket. Slide the second washer onto the free end of the pin and attach the second safety ring. This will function as the locking pin to hold the transducer in the operational position when underway.

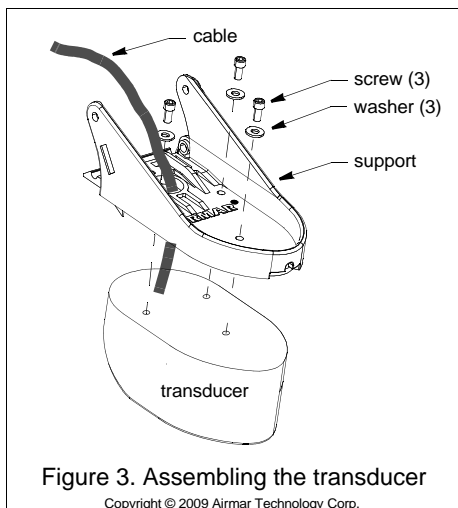

Figure 3. Assembling the transducer

Copyright © 2009 Airmar Technology Corp.

Compensating for Transom Angle

CAUTION: Do not position the leading edge of the transducer deeper in the water than the trailing edge to avoid aeration.

For the best performance, the transducer beam must be aimed straight at the bottom (see Figure 5). Since the transom of most boats is angled, the bracket must compensate for it. Measure the transom angle of the boat with an angle finder.

Standard transom (12° transom angle)—The bracket is designed for a standard 12° transom angle. *No shim is needed for this installation.* If your boat is capable of speeds above 20kn (28MPH), install the bracket with one 3° shim, *taper down*. This will ensure that the transducer is in contact with the water at high speeds.

Shims—The bracket is supplied with three shims; each one has a 3° angle. Up to three shims can be combined for a maximum of 9°. The shims are designed to mate together. Two bosses on the face fit into recesses in the back of another shim or the holes in the bracket.

- **Transom angles greater than 12°**—Add the appropriate number of shims with the taper up to the 12° bracket angle.
- **Transom angles less than 12°**—To reduce the bracket's 12° angle, group the appropriate number of shims with the taper down.

If you are unsure about using the shim(s), experiment with the them by following the instructions "Mounting & Adjusting the Bracket."

Hole Drilling

1. At the selected mounting location, position the assembly so the transducer projects 3mm (1/8") below the bottom edge of the transom (see Figure 1). Be sure any shim(s) is in place. (You may want to tape the shim(s) to the bracket temporarily.) With the transducer in the operational position, mark the bottom corners of the bracket.
2. Remove the transducer assembly from the bracket by removing the locking pin and the hinge pin (see Figure 4). Hold the bracket with any shim(s) in place against the transom at the marked location. Draw an "X" at 12mm (1/2") from the top and the bottom of each slot (see Figure 6).
3. Using a 5mm, #4, or 7/32" drill bit, drill the four holes.
Fiberglass hull—Minimize surface cracking by running the drill in reverse until the gelcoat is penetrated.

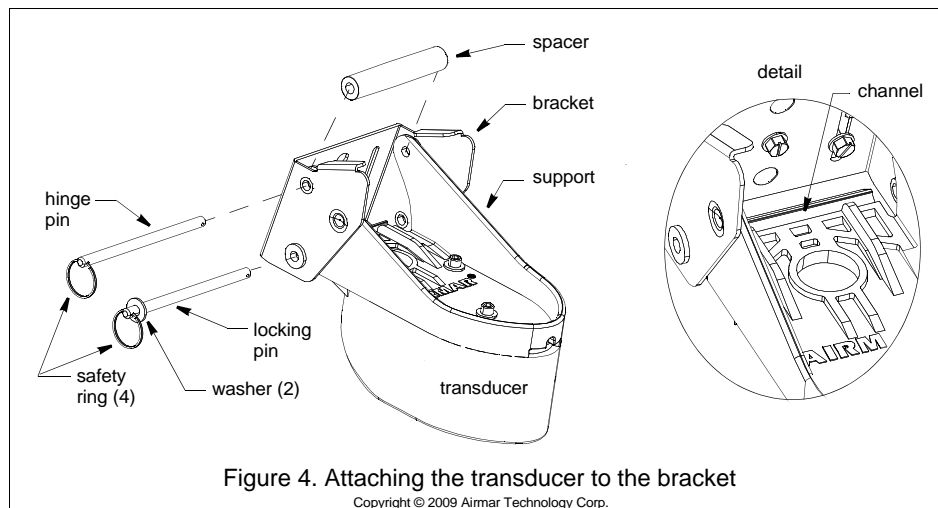
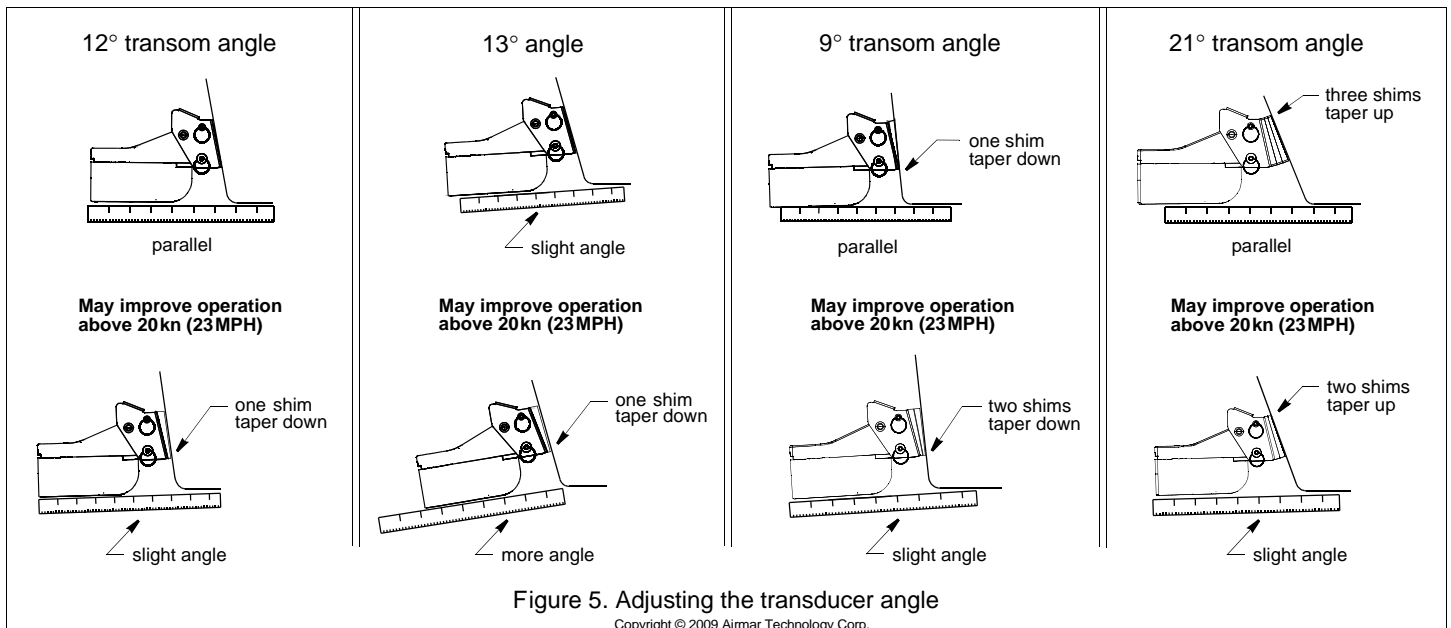

Figure 4. Attaching the transducer to the bracket

Copyright © 2009 Airmar Technology Corp.



Mounting & Adjusting the Bracket

CAUTION: Do not position the transducer deeper in the water than necessary to avoid increasing drag, spray, and water noise and reducing boat speed.

CAUTION: The stainless steel bracket must be isolated from a metal hull to prevent electrolytic corrosion. If no shim is being used, place non-metal insulating washers between the bracket and the metal hull.

1. Apply marine sealant to the threads of four of the hex-washer-head screws to prevent water seepage into the transom. Being sure any shim(s) is in place, screw the bracket to the hull using a socket wrench (see Figure 4). *Do not tighten the screws completely at this time.*
2. Reinstall the transducer. While holding the transducer assembly against the bracket, insert the hinge pin through the *upper* hole in the bracket and the support. Slide the spacer onto the pin and push it through the remaining hole in the support and the bracket. Reattach the safety ring.
3. Slide a washer onto the locking pin. Push it through the *lower* hole in the bracket, slide it along the channel in the support, and through the second hole in the bracket. Slide the second washer onto the free end of the pin and reattach the safety ring.
4. With the transducer in the operational position, Use a straight edge to sight the underside of the transducer relative to the underside of the hull (see Figure 5). The trailing edge of the transducer should be 1–6mm (1/16–1/4") below the leading edge.

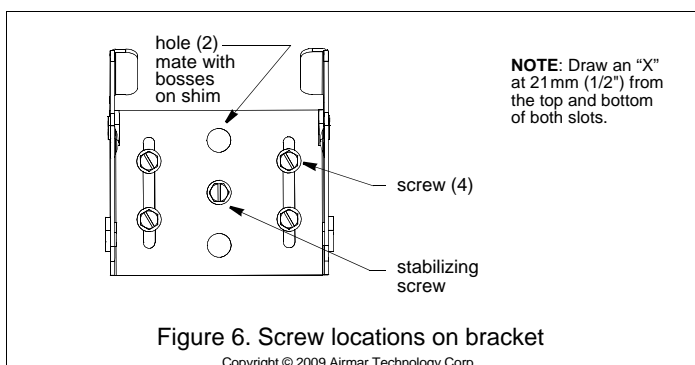

5. Using the vertical adjustment space in the bracket slots, slide the assembly up or down until the bottom inside corner of the transducer projections 0–3mm (0–1/8") below the bottom of the hull (see Figure 1). When you are satisfied with the position of the transducer, tighten the four bracket screws. For clear access to the screws, remove the transducer assembly from the bracket (see Figure 4). *When reattaching, be sure to include the spacer.*

Testing on the Water

1. Test the transducer at 200kHz with the engine off.
2. Become familiar with your echosounder's performance at a speed of 4kn (5 MPH).
3. Gradually increase the boat speed and observe the gradual decline of performance due to turbulent water flowing over the transducer's active surface.
NOTE: *As the speed increases the performance at 50kHz will deteriorate more rapidly because more acoustic noise is generated at low frequencies.*
4. If the decline in performance is sudden (not gradual), identify the boat speed at which the onset occurred. Return the boat to this speed, then gradually increase speed while making moderate turns in both directions.
5. If the performance improves while turning to the side on which the transducer is installed, it's position probably needs adjustment. The transducer is probably in turbulent or aerated water.

To improve performance, try the following, *one at a time*, in the order given.

- A. Increase the transducer's angle in the water. Review "Shims" and see Figure 5.
- B. Move the transducer deeper into the water in increments of 3mm (1/8") (see Figure 1).
- C. Move the transducer closer to the centerline of the boat. Fill unused screw holes with marine sealant.

Stabilizing the Bracket

1. Prevent the bracket from moving out of position with the remaining hex-washer-head screw. Drill the hole for the stabilizing screw through the center hole of the bracket, any shim(s), and the hull (see Figure 6).

2. Apply sealant to the threads of the remaining screw to prevent water seeping into the transom.
3. Fasten the stabilizing screw into place with a socket wrench. For clear access to the screw, remove the transducer assembly from the bracket (see Figure 4). *When reattaching the transducer, be sure to include the spacer.*

Cable Routing

Route the cable over the transom for a detachable installation. For permanent mounting, route the cable through a drain hole or through a new hole drilled in the transom above the waterline.

CAUTION: Do not remove the connector to ease cable routing. If the cable must be cut and spliced, use Airmar's splash-proof Junction Box No. 33-035 and follow the instructions provided. Removing the waterproof connector or cutting the cable, except when using a water-tight junction box, will void the sensor warranty.

1. If a hole must be drilled through the transom, choose a location **well above the waterline** (see Figure 7). Check for obstructions such as trim tabs, pumps, or wiring inside the hull. Mark the location with a pencil. Drill the hole using the appropriate size bit to accommodate the connector.
- Fiberglass hull**—Minimize surface cracking by running the drill in reverse until the gelcoat is penetrated.
2. Route the cable over *or* through the transom.
3. On the outside of the hull, secure the cable against the transom using the cable clamps. Position one cable clamp 30cm (12") above the bracket. Mark the mounting hole with a pencil.
4. Position the second cable clamp halfway between the first clamp and the cable hole. Mark this mounting hole.
5. If a hole has been drilled through the transom, open the large slot in the transom cable cover. Position the cover over the cable where it enters the hull. Mark the two mounting holes.
6. At each of the marked locations, use a 3mm or 1/8" bit to drill a hole 10mm (3/8") deep. To prevent drilling too deeply, wrap masking tape around the bit 10mm (3/8") from the point.
7. Apply marine sealant to the threads of the #6 x 1/2" self-tapping screw to prevent water from seeping into the transom. Position the two cable clamps over the cable and fasten them in place.
8. If you have drilled a hole through the transom, apply marine sealant to the space around the cable where it passes through the transom. Push the cable cover over the cable and screw it in place.
9. Route the cable to the instrument being careful not to tear the cable jacket when passing it through the bulkhead(s) and other parts of the boat. Use grommets to prevent chafing. To reduce electrical interference, separate the transducer cable from other electrical wiring and the engine(s). Coil any excess cable and secure it in place with cable ties to prevent damage.
10. Refer to your echosounder owner's manual to connect the transducer to the instrument.

Checking for Leaks

WARNING: Do not leave the boat in the water unchecked for several days. When the boat is placed in the water, **immediately** check for leaks around the screws and any other holes drilled in the hull. Note that very small leaks may not be readily observed.

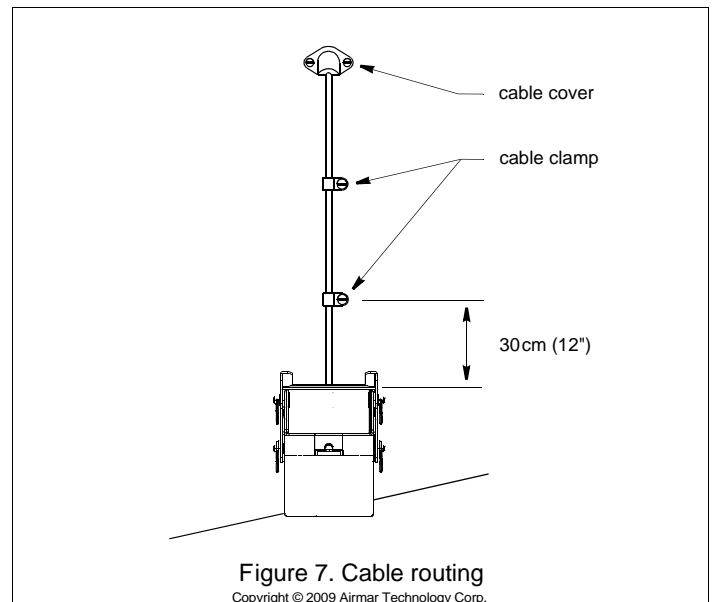

Maintenance

Anti-fouling Paint

CAUTION: Do not paint the exposed temperature button. Doing so will slow the sensor's response time.

Aquatic growth can accumulate rapidly on the transducer's surface reducing performance within weeks. Surfaces exposed to salt water *that do not interlock must* be coated with anti-fouling paint. Use **water-based** anti-fouling paint only. *Never* use ketone-based paint, since ketones can attack many types of plastic possibly damaging the transducer. Repaint every 6 months or at the beginning of each boating season.

Cleaning

CAUTION: Do not use a lubricant on the bracket; grit will stick to it increasing friction and wear.

Clean the sensor with a Scotch-Brite® scour pad and mild household detergent taking care to avoid making scratches. If the fouling is severe, lightly wet sand with fine grade wet/dry paper.

Parts

The information needed to order a replacement transducer is printed on the cable tag. Do not remove this tag. When ordering, specify the part number, date, and frequency in kHz. For convenient reference, record this information on the top of page one.