

OWNER'S GUIDE & INSTALLATION INSTRUCTIONS

Thru-Hull *with Stem*

Depth Transducer

with Temperature Sensor

Models: **B45, B258, B260, B265LH, B265LM, B271W, B275LHW, B285HW, B285M, SS258, SS260, SS270W, SS505**

U.S. Patent No. 7,369,45; 8,582,393. UK Patent No. 2 414 077

Record the information found on the cable tag for future reference.

Part No. _____ Date _____ Frequency _____ kHz

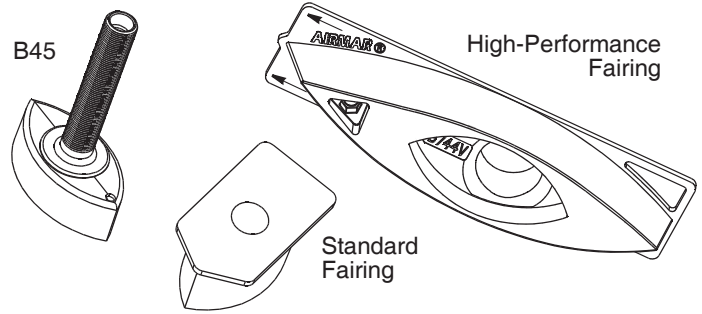

Follow the precautions below for optimal product performance and to reduce the risk of property damage, personal injury, and/or death.

WARNING: A High-Performance Fairing must be installed following the installation instructions that accompany the fairing. A High-Performance Fairing requires an anti-rotation bolt to keep the fairing from turning while the boat is underway.

WARNING: Always wear safety goggles and a dust mask when installing.

WARNING: Immediately check for leaks when the boat is placed in the water. Do not leave the boat unchecked for more than three hours. Even a small leak may allow considerable water to accumulate.

CAUTION: CHIRP transducer—Always operate the transducer in water. Operating in air will allow the transducer to overheat resulting in failure.

CAUTION: Bronze transducer—Never mount in a metal hull, because electrolytic corrosion will occur.

CAUTION: Stainless steel housing in a metal hull requires using a Fairing Kit to isolate the stainless steel transducer from the metal hull. Failure to do so will cause electrolytic corrosion.

CAUTION: Never install a metal transducer on a vessel with a positive ground system.

CAUTION: Never pull, carry, or hold the transducer by the cable as this may sever internal connections.

CAUTION: Never strike the transducer.

CAUTION: Never use solvents. Cleaner, fuel, sealant, paint, and other products may contain solvents that can damage plastic parts, especially the transducer's face.

IMPORTANT: Read the instructions completely before proceeding with the installation. These instructions supersede any other instructions in your instrument manual if they differ.

Identify Your Model

The model name is printed on the cable tag.

Tools & Materials

Safety goggles

Dust mask

Electric drill

Drill bits and hole saws:

Pilot hole	3mm or 1/8"
B45, SS505	22mm or 7/8"
B258, B271W, B285HW, B285M, SS258	30mm or 1-3/16"
B260, B265LH, B265LM, B275LHW, SS260, SS270W	33mm or 1-5/16"

Sandpaper

Mild household detergent *or* weak solvent (such as alcohol)

File (installation in a metal hull)

Angle finder (installation with a fairing)

Band saw (installation with a fairing)

Rasp *or* power tool (installation with a fairing)

Marine sealant (suitable for below waterline)

Slip-joint pliers

Grommet(s) (some installations)

Cable ties

Water-based anti-fouling paint (**mandatory in salt water**)

Installation in a cored fiberglass hull: (see page 4)

Drill bits and hole saws for hull interior:

B45, SS505	35mm or 1-3/8"
B258, B271W, SS258, B285HW, B285M	40mm, 41mm, or 1-5/8"
B260, B265LH, B265LM, B275LHW, SS260, SS270W	42mm or 1-5/8"

Cylinder, wax, tape, and casting epoxy

About Fairings

Most vessels have some deadrise angle at the mounting location. If the transducer is mounted directly to the hull, the sound beam will be tilted to the side at the same angle as the deadrise. A fairing is strongly recommended if the deadrise angle exceeds 10°. Made of a high-impact polymer with an integrated cutting guide, an Airmar fairing is safer and easier to cut with a band saw and shape with hand tools than custom fairings.

- Orients the sound beam straight down by mounting the transducer parallel to the water surface.
- Mounts the transducer deeper in the water for clean flow under the transducer's face.
- **Airmar High-Performance Fairing** has a long streamlined shape, directing water around the transducer to minimize drag. Performance is excellent above 15kn (18MPH). (To order see "Replacement Parts" on page 4.)

Applications

- **Bronze** transducer recommended for fiberglass or wood hull only.
- **Stainless steel** transducer compatible with all hull materials. Recommended for aluminum hulls to prevent electrolytic corrosion provided the stainless steel transducer is isolated from the metal hull.

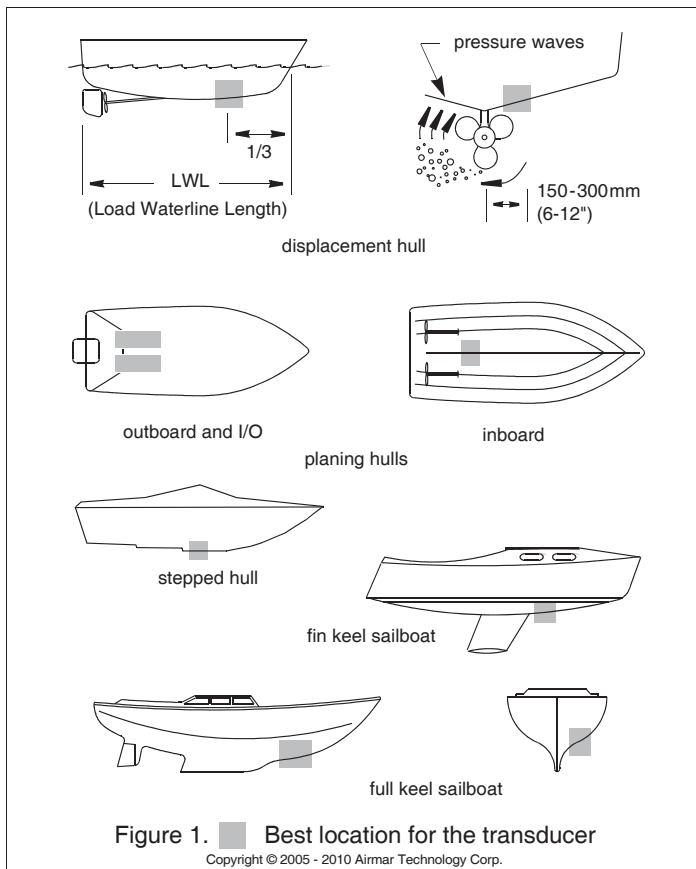

Mounting Location

Guidelines

CAUTION: Do not mount in line with or near water intake or discharge openings or behind strakes, struts, fittings, or hull irregularities that will disturb the water flow.

CAUTION: Do not mount the sensor where the boat may be supported during trailering, launching, hauling, or storage to avoid damaging the transducer's face.

- The water flowing under the hull must be smooth with a minimum of bubbles and turbulence (especially at high speeds).
- The transducer must be continuously immersed in water.
- The transducer beam must be unobstructed by the keel or propeller shaft(s).
- Choose a location away from interference caused by power and radiation sources such as: the propeller(s) and shaft(s), machinery, other echosounders, and other cables. The lower the noise level, the higher the echosounder gain setting that can be used.
- Choose a location with a minimal deadrise angle.
- Choose an accessible spot inside the vessel with adequate space for the height of the stem and tightening the nut.
- **CHIRP transducer**—Mount in a cool well-ventilated area away from the engine to avoid overheating.

Boat Types (see Figure 1)

- **Displacement hull powerboat**—Locate 1/3 of the way along the LWL and 150–300mm (6–12") off the centerline. The starboard side of the hull where the propeller blades are moving downward is preferred.
- **Planing hull powerboat**—Mount well aft near the centerline and well inboard of the first set of lifting strakes to ensure that it is in contact with the water at high speeds. The starboard side of the hull where the propeller blades are moving downward is preferred.

Outboard and I/O—Mount just forward and to the side of the engine(s).

Inboard—Mount well ahead of the propeller(s) and shaft(s).

Stepped hull—Mount just ahead of the first step.

Boat capable of speeds above 25 kn (29MPH)—Review transducer location and operating results of similar boats before proceeding.

- **Fin keel sailboat**—Mount to the side of the centerline and forward of the fin keel 300–600mm (1–2').
- **Full keel sailboat**—Locate amidships and away from the keel at the point of minimum deadrise angle.

Installation: No Fairing or Standard Fairing Only

IMPORTANT: If installing the transducer with NO fairing, disregard all references to a fairing and backing block.

Hole Drilling

Cored fiberglass hull—Follow separate instructions on page 4.

1. Drill a 3mm or 1/8" pilot hole perpendicular to the waterline from inside the hull (see Figure 2). If there is a rib, strut, or other hull irregularity near the selected mounting location, drill from the outside.
2. Using the appropriate size drill bit, cut a hole from outside the hull. *Be sure to hold the drill plumb, so the hole will be perpendicular to the water surface.*
3. Sand and clean the area around the hole, inside and outside, to ensure the marine sealant will adhere properly to the hull. If there is any petroleum residue inside the hull, remove it with either a mild household detergent or a weak solvent (alcohol) before sanding.

Metal hull—Remove all burrs with a file and sandpaper.

Cutting the Standard Fairing

WARNING: High-Performance Fairing—For your safety it is mandatory to follow the Installation Instructions that come with the fairing.

CAUTION: The arrow/pointed end of the fairing points forward toward the bow. Be sure to orient the fairing on the band saw, so the angle cut matches the intended side of the hull and not the mirror image.

1. Measure the deadrise angle of the hull at the selected location (see Figure 2).

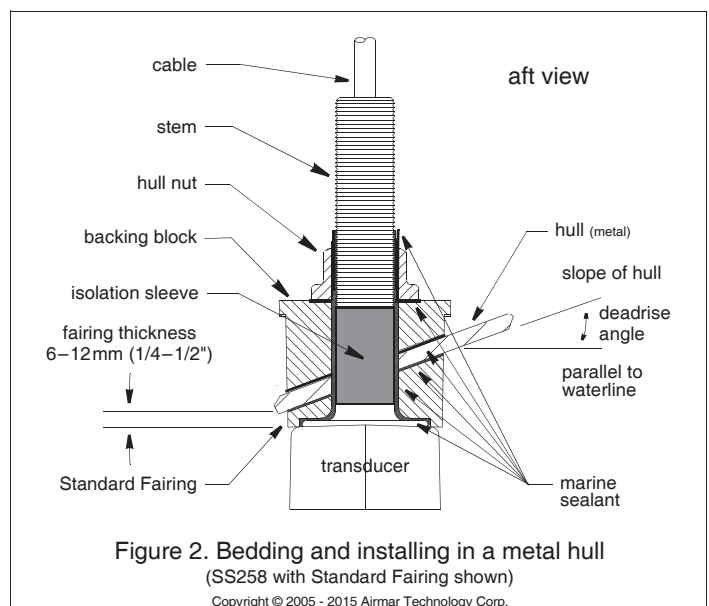

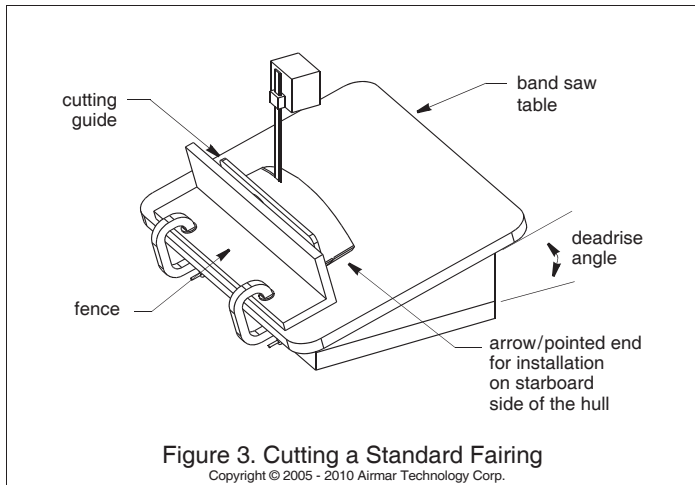

2. Tilt the band saw table to the measured angle and secure the cutting fence (see Figure 3).
3. Place the fairing on the table, so the cutting guide rests against the fence. The arrow/pointed end will be pointing *toward* you for installation on the starboard side of the boat or *away* from you for installation on the port side (see Figure 4).
4. Adjust the cutting fence, so the fairing will be cut in about two equal parts (see Figure 3). *The section that will become the fairing must be between 6–12mm (1/4–1/2") at its thinnest dimension (see Figure 2).*
5. Recheck steps 1 through 4. Then cut the fairing.
6. Shape the fairing to the hull as precisely as possible with a rasp or power tool.
7. Use the remaining section of the fairing with the cutting guide for the backing block.

Bedding

CAUTION: Be sure all surfaces to be bedded are clean and dry.

1. Remove the hull nut (see Figure 5).
2. Thread the transducer cable through the fairing (if used).
3. Apply a 2mm (1/16") thick layer of marine sealant to the surface of the transducer that will contact the hull/fairing and up the stem. *The sealant must extend 6mm (1/4") higher than the combined thickness of the hull, fairing and backing block (if used), and the hull nut.* This will ensure there is marine sealant in the threads to seal the hull and hold the hull nut securely in place.

Stainless steel transducer/stem in a metal hull—Slide the isolation sleeve over the bedded transducer stem as far down as possible (see Figure 2). Apply a 2mm (1/16") thick layer of the marine sealant to the outside of the sleeve.

4. Apply a 2mm (1/16") thick layer of marine sealant to the following surfaces (see Figure 5):
 - Fairing that will contact the hull
 - Backing block that will contact the hull interior
 - Hull nut that will contact the hull/backing block
5. **Standard Fairing**—Seat the transducer firmly in/against the fairing with a pushing twisting motion. Be sure the button on the fairing mates with the recess in the transducer housing.

Installing

1. From outside the hull, thread the cable through the mounting hole. Then push the stem of the transducer through the hole using a twisting motion to squeeze out excess sealant. *Take care to align the transducer with the blunt/button/arrow end*

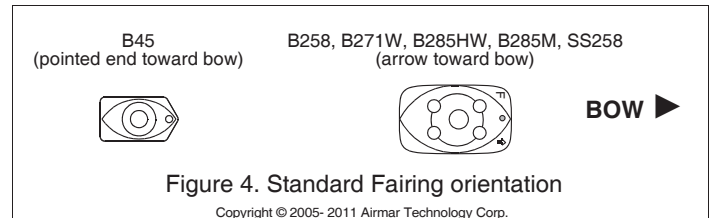

facing forward toward the bow. The long side must be parallel to the centerline of the boat (see Figure 4).

Stainless steel transducer in a metal hull—Be sure the isolation sleeve is between the transducer stem and the hull (see Figure 2). However, the isolation sleeve must be below the hull nut to prevent the sleeve from interfering with tightening the nut.

2. From inside the hull, slide the backing block (if installing with a fairing) and the hull nut onto the cable. Seat any backing block against the hull, being sure the arrow end faces forward toward the bow. Screw the hull nut in place and tighten it with slip-joint pliers (see Figures 4 and 5).

Cored fiberglass hull—Do not over-tighten, crushing the hull.

Wood hull—Allow for the wood to swell before tightening the nut.

3. Remove any excess marine sealant on the outside of the hull/fairing to ensure smooth water flow under the transducer.

Cable Routing & Connecting

CAUTION: If the sensor came with a connector, do not remove it to ease cable routing. If the cable must be cut and spliced, use Airmar's splash-proof Junction Box No. 33-035 and follow the instructions supplied. Removing the waterproof connector or cutting the cable, except when using a water-tight junction box, will void the sensor warranty.

1. Route the cable to the instrument being careful not to tear the cable jacket when passing it through the bulkhead(s) and other parts of the boat. Use grommet(s) to prevent chafing. To reduce electrical interference, separate the transducer cable from other electrical wiring and the engine. Coil any excess cable and secure it in place with cable ties to prevent damage.
2. Refer to the instrument owner's manual to connect the transducer to the instrument.

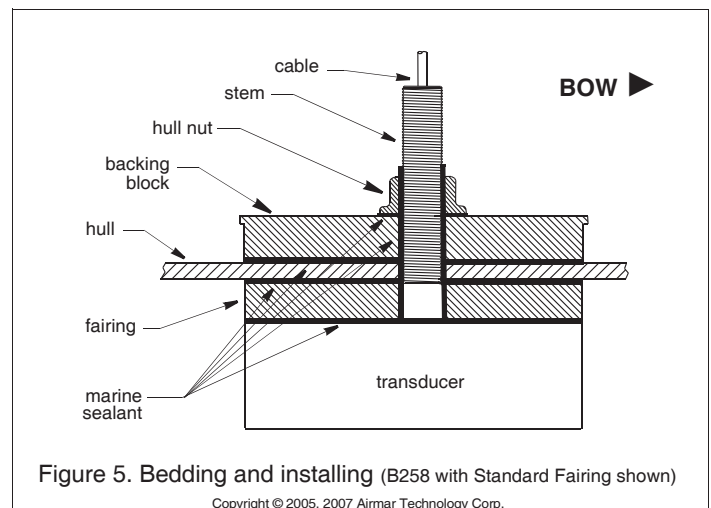

Checking for Leaks

When the boat is placed in the water, **immediately** check around the transducer for leaks. Note that very small leaks may not be readily observed. Do not leave the boat in the water for more than 3 hours before checking it again. If there is a small leak, there may be considerable bilge water accumulation after 24 hours. If a leak is observed, repeat "Bedding" and "Installing" **immediately** (see page 3).

Installation in a Cored Fiberglass Hull

The core (wood or foam) must be cut and sealed carefully. The core must be protected from water seepage, and the hull must be reinforced to prevent it from crushing under the hull nut, allowing the transducer to become loose.

CAUTION: Completely seal the hull to prevent water seepage into the core.

1. Drill a 3mm or 1/8" pilot hole perpendicular to the waterline from inside the hull (see Figure 6). If there is a rib, strut, or other hull irregularity near the selected mounting location, drill from the outside. (If the hole is drilled in the wrong location, drill a second hole in a better location. Apply masking tape to the outside of the hull over the incorrect hole and fill it with epoxy.)
2. Using the appropriate size drill bit, cut a hole from outside the hull through the *outer* skin only. *Be sure to hold the drill plumb, so the hole will be perpendicular to the water surface.*
3. The optimal interior hole diameter is affected by the hull's thickness and deadrise angle. It must be large enough in diameter to allow the core to be completely sealed.

Using the appropriate size drill bit for the hull interior, cut through the *inner* skin and most of the core from inside the hull keeping the drill perpendicular to the hull. The core material can be very soft. Apply only light pressure to the drill bit after cutting through the *inner* skin to avoid accidentally cutting the *outer* skin.

4. Remove the plug of core material so the *inside* of the outer skin and the inner core of the hull is fully exposed. Sand and clean the inner skin, core, and the outer skin around the hole.

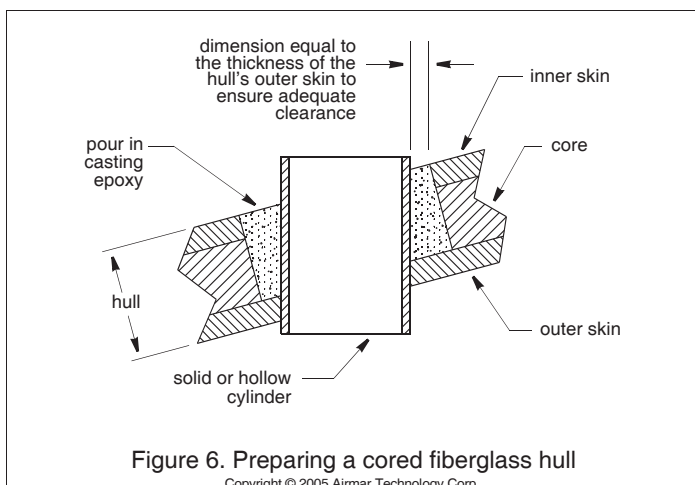

5. Coat a hollow or solid cylinder of the correct diameter with wax and tape it in place. Fill the gap between the cylinder and hull with casting epoxy. After the epoxy has set, remove the cylinder.
6. Sand and clean the area around the hole, inside and outside, to ensure that the sealant will adhere properly to the hull. If there is any petroleum residue inside the hull, remove it with either mild household detergent or a weak solvent (alcohol) before sanding.
7. Proceed with "Cutting the Standard Fairing" on page 2.

Anti-fouling Paint

Surfaces exposed to salt water must be coated with anti-fouling paint. Use **water-based** anti-fouling paint only. Never use ketone-based paint since ketones can attack many plastics possibly damaging the transducer. Reapply anti-fouling paint every 6 months or at the beginning of each boating season.

Maintenance, Parts & Replacement

Cleaning

Aquatic growth can accumulate rapidly on the transducer's surface reducing its performance within weeks. Clean the surface with a Scotch-Brite® scour pad and mild household detergent taking care to avoid making scratches. If the fouling is severe, lightly wet sand with fine grade wet/dry paper.

Replacement Transducer & Parts

The information needed to order a replacement transducer is printed on the cable tag. Do not remove this tag. When ordering, specify the part number, date, and frequency in kHz. For convenient reference, record this information on the top of page 1.

Lost, broken, and worn parts should be replaced immediately.

Model	Hull Nut	Fairing Type	Fairing No.
B45	02-031-3	Standard	33-351-01
		High-Performance	33-509-01
B258, B271W, B285HW, B285M	02-222-03	Standard	33-226-01
		High-Performance	33-523-01
B260	02-036-2	High-Performance	33-391-01
B265LH, B265LM, B275LHW	02-036-2	High-Performance	33-391-01
SS258	02-539-01	Standard	33-226-01
		High-Performance	33-523-01
SS260	02-036-03	High-Performance	33-391-01
SS270W	02-036-03	High-Performance	33-391-01
SS505	02-111-01	High-Performance	33-355-01