

CHIRP

Upgrade Your Sounder to a Serious Fishfinding Machine!
Only possible with the use of an AIRMAR broadband transducer.

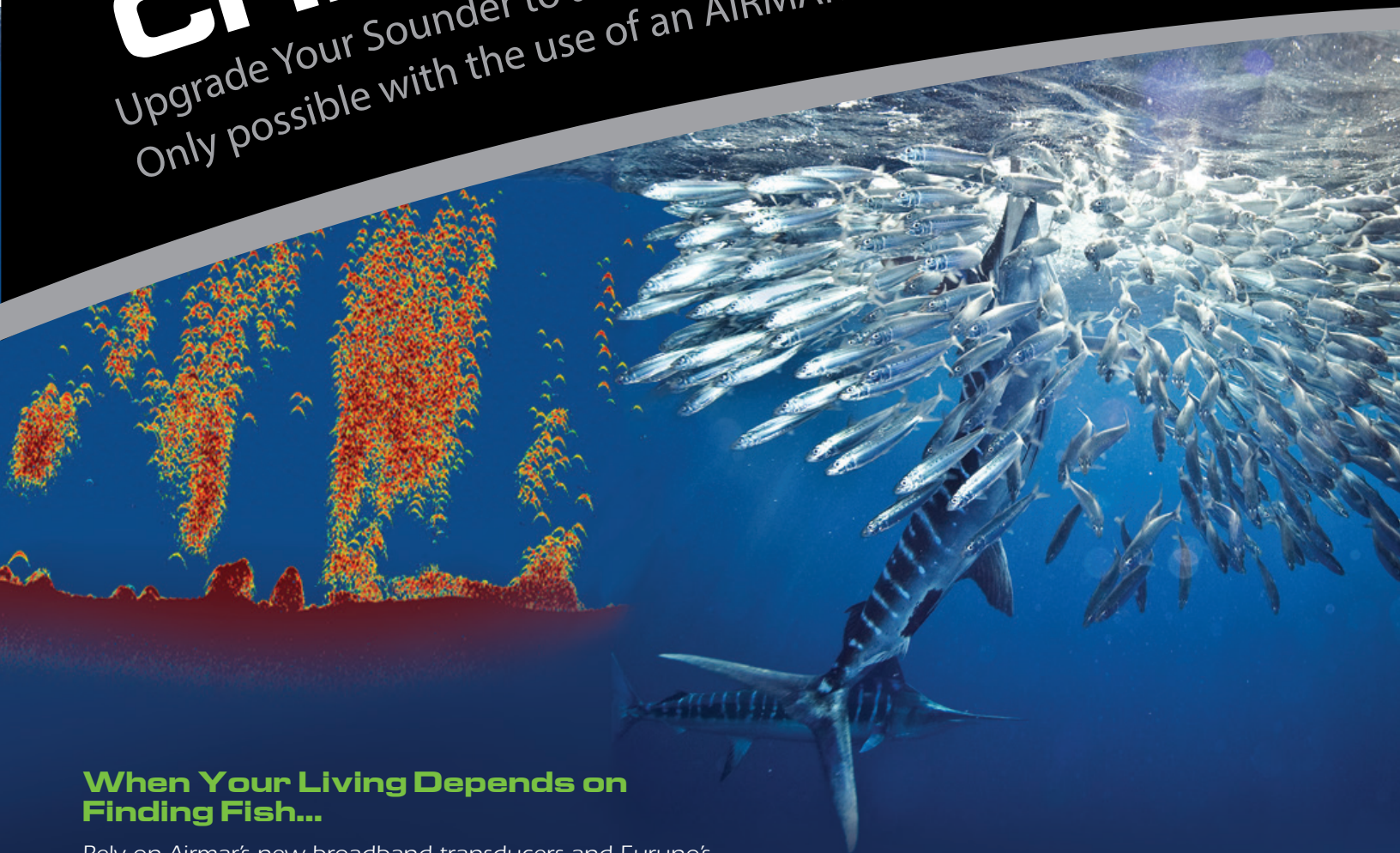

When Your Living Depends on Finding Fish...

Rely on Airmar's new broadband transducers and Furuno's TruEcho CHIRP DFF1-UHD echo sounder for the ultimate fishing mission. The DFF1-UHD merges the very latest CHIRP technology with bottom discrimination and Accu-Fish, bringing you the next evolution of CHIRP Fish Finders. Enjoy eye-popping target definition, displaying bait balls separately from predator fish. Then, watch the unique Bottom Discrimination Mode reveal sea floor structure and composition, while Accu-Fish unlocks sophisticated fish size and depth information.

"By far the most amazing results from a CHIRP sounder."

**DEEPER.
BROADER.
CLEARER.**



FURUNO



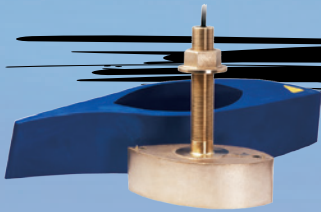

B265LH Low & High-Frequency

Thru-Hull

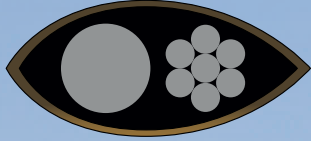

8-Internal Broadband Ceramic Assemblies

- Depth & fast-response water-temperature sensor
- Low—CHIRPS from 42 kHz to 65 kHz
 - Beamwidth 25° to 16°
- High—CHIRPS from 130 kHz to 210 kHz
 - Beamwidth 10° to 6°
- 103 kHz of total bandwidth from one transducer
- Covers popular fishing frequencies of 50 and 200 kHz plus everything else in the bandwidth
- Fishing Profile: Commercial and recreational inshore and offshore fishing (deep-water canyon and sea-mount tracking)
- Bronze transducer housing with High-Performance Fairing
- Boat Size: 8 m (25') and above
- Hull Type: Fiberglass or wood



DIMENSIONS

B265LH Transducer

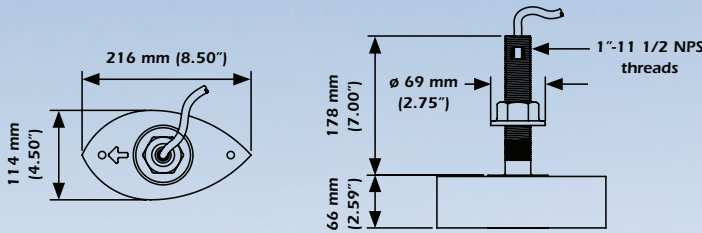

Transducer and High-Performance Fairing

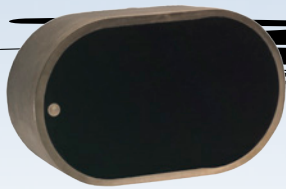
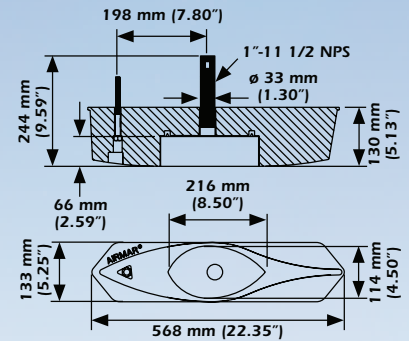

PM265LH Low & High-Frequency

Pocket Mount

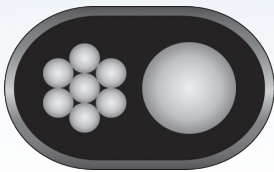

8-Internal Broadband Ceramic Assemblies

- Depth & fast-response water-temperature sensor
- Low—CHIRPS from 42 kHz to 65 kHz
 - Beamwidth 25° to 16°
- High—CHIRPS from 130 kHz to 210 kHz
 - Beamwidth 10° to 6°
- 103 kHz of total bandwidth from one transducer
- Covers popular fishing frequencies of 50 and 200 kHz plus everything else in the bandwidth
- Fishing Profile: Commercial and recreational inshore and offshore fishing (deep-water canyon and sea-mount tracking)
- Bronze transducer housing
- Boat Size: 8 m (25') and above
- Hull Type: Fiberglass only



DIMENSIONS

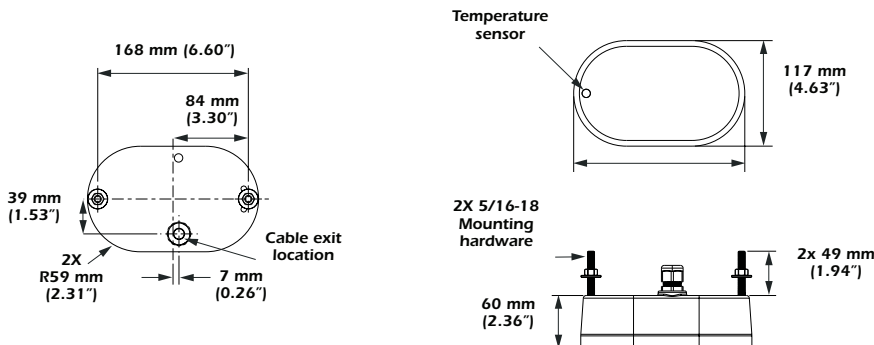



TM265LH Low & High-Frequency

Transom Mount

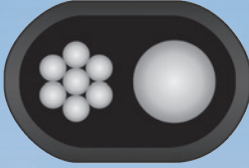

8-Internal Broadband Ceramic Assemblies

- Depth & fast-response water-temperature sensor
- Low—CHIRPS from 42 kHz to 65 kHz
 - Beamwidth 25° to 16°
- High—CHIRPS from 130 kHz to 210 kHz
 - Beamwidth 10° to 6°
- 103 kHz of total bandwidth from one transducer
- Covers popular fishing frequencies of 50 and 200 kHz plus everything else in the bandwidth
- Fishing Profile: Commercial and recreational inshore and offshore fishing (deep-water canyon and sea-mount tracking)
- Urethane transducer housing with stainless steel mounting bracket
- Boat Size: 8 m (25') and above
- Hull Type: Fiberglass, wood or metal

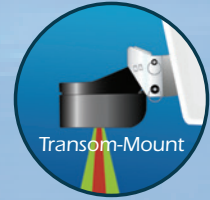

DIMENSIONS

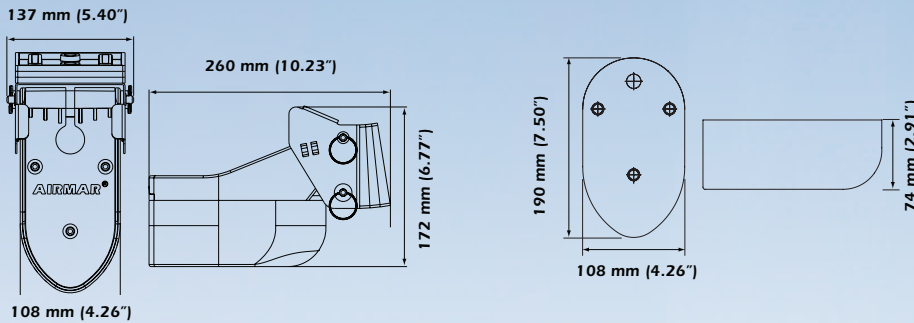

CM265LH Low & High-Frequency

Tank Mount

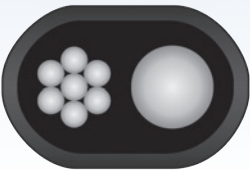

8-Internal Broadband Ceramic Assemblies

- Depth & fast-response water-temperature sensor
- Low—CHIRPS from 42 kHz to 65 kHz
 - Beamwidth 25° to 16° beamwidth
- High—CHIRPS from 130 kHz to 210 kHz
 - Beamwidth 10° to 6° beamwidth
- 103 kHz (CM265LH) of total bandwidth from one transducer
- Covers popular fishing frequencies of 50 and 200 kHz plus everything else in the bandwidth
- Fishing Profile: Commercial and recreational inshore and offshore fishing (deep-water canyon and sea-mount tracking)
- Urethane housing
- Boat Size: 8 m (25') and above
- Hull Type: Fiberglass, wood or tank installation



DIMENSIONS

