

# **FURUNO**

## **OPERATOR'S MANUAL**

*Bottom Discrimination Sounder*

Model **BBDS1**

---

# IMPORTANT NOTICES

---

## General

- This manual has been authored with simplified grammar, to meet the needs of international users.
- The operator of this equipment must read and follow the descriptions in this manual. Wrong operation or maintenance can cancel the warranty or cause injury.
- Do not copy any part of this manual without written permission from FURUNO.
- If this manual is lost or worn, contact your dealer about replacement.
- The contents of this manual and equipment specifications can change without notice.
- The example screens (or illustrations) shown in this manual can be different from the screens you see on your display. The screens you see depend on your system configuration and equipment settings.
- Save this manual for future reference.
- Any modification of the equipment (including software) by persons not authorized by FURUNO will cancel the warranty.
- All brand and product names are trademarks, registered trademarks or service marks of their respective holders.
- Microsoft, Windows, Windows Vista and Outlook are registered trademarks or trademarks of the Microsoft Corporation in the United States and other countries.

## How to discard this product

Discard this product according to local regulations for the disposal of industrial waste. For disposal in the USA, see the homepage of the Electronics Industries Alliance for the correct method of disposal.

## How to discard a used battery

Some FURUNO products have a battery(ies). To see if your product has a battery, see the chapter on Maintenance. Follow the instructions below if a battery is used. Tape the + and - terminals of battery before disposal to prevent fire, heat generation caused by short circuit.

### In the European Union

The crossed-out trash can symbol indicates that all types of batteries must not be discarded in standard trash, or at a trash site. Take the used batteries to a battery collection site according to your national legislation and the Batteries Directive 2006/66/EU.

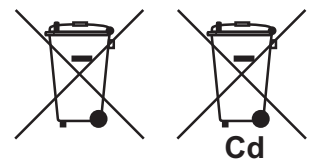

### In the USA

The Mobius loop symbol (three chasing arrows) indicates that Ni-Cd and lead-acid rechargeable batteries must be recycled. Take the used batteries to a battery collection site according to local laws.

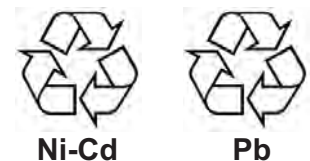



### In the other countries

There are no international standards for the battery recycle symbol. The number of symbols can increase when the other countries make their own recycle symbols in the future.









# SAFETY INSTRUCTIONS





The user and installer must read the appropriate safety instructions before attempting to install or operate the equipment.

|  |   |
|--|---|
|  <b>WARNING</b> | Indicates a potentially hazardous situation which, if not avoided, could result in death or serious injury. |
|  <b>CAUTION</b> | Indicates a potentially hazardous situation which, if not avoided, may result in minor or moderate injury.  |





|  |  |  |
|--|--|--|
|  Warning, Caution |  Prohibitive Action |  Mandatory Action |
|--|--|--|

## Safety instructions for the operator

|  <b>WARNING</b> |  |
|--|--|
|                | Do not open the equipment.<br>Only qualified personnel should work inside the equipment.   |
|               | Do not disassemble or modify the equipment.<br>Fire, electrical shock or serious injury can result.  |
|               | Turn off the equipment immediately if it is emitting smoke or fire.<br>Fire or electrical shock can result if the power is left on.  |
|               | Turn off the power immediately if water leaks into the equipment or an object is dropped inside the equipment.<br>Continued use can cause fire or electrical shock.  |
|               | Turn off the power immediately if you feel the equipment is acting abnormally.<br>If the equipment is very warm or is emitting strange noises turn off the power immediately and contact your dealer for advice. |





|  <b>WARNING</b> |  |
|--|--|
|                | Do not operate the equipment with wet hands.<br>Electrical shock can result.   |
|               | Do not place liquid-filled containers on the top of the equipment.<br>Electrical shock can result.   |
|               | Do not install the equipment where it may be subjected to rain or water splash.<br>Fire or electrical shock can result if water gets inside the equipment. |
|               | Use the proper fuse.<br>Use of a wrong fuse can damage the equipment and may cause fire.   |





A warning label is attached to the equipment. Do not remove the label. If a label is missing or illegible, contact a FURUNO agent or dealer about replacement.

|  |
|--|
|  <b>WARNING</b>  |
| To avoid electrical shock, do not remove cover. No user-serviceable parts inside.  |
|                  |

Name: Warning Label (1)  
Type: 86-003-1011-3  
Code No.: 100-236-233-10

## Safety instructions for the installer

|  <b>WARNING</b> |  |
|--|--|
|                 | Do not open the equipment.<br>Only qualified personnel should work inside the equipment.   |
|                 | Turn off the power at the main switchboard before beginning the installation.<br><br>Fire or electrical shock can result if the power is left on.  |
|                 | Confirm that there is no water leakage at the transducer and temperature sensor.<br><br>Water leakage can sink the vessel. Also, confirm that neither the transducer or sensor is loosened by vibration. The installer is solely responsible for the installation. |
|                | Confirm that the power supply voltage is within the rating of this equipment.<br><br>Incorrect voltage will damage the equipment and may cause fire.   |

|  <b>CAUTION</b> |  |                  |                  |        |        |
|---|--|------------------|------------------|--------|--------|
|                  | The transducer cable must be handled carefully, following the guidelines below. <ul style="list-style-type: none"> <li>• Keep fuels and oils away from the cable.</li> <li>• Locate the cable away from chemicals.</li> <li>• Locate the cable away from locations where it might be damaged.</li> </ul>   |                  |                  |        |        |
|                  | Do not turn on the power with the transducer exposed to air.<br><br>Damage to the transducer may result.   |                  |                  |        |        |
|                  | Observe the following compass safe distances to prevent interference to a magnetic compass: <table border="1" style="margin: 10px auto;"> <thead> <tr> <th>Standard compass</th> <th>Steering compass</th> </tr> </thead> <tbody> <tr> <td style="text-align: center;">0.30 m</td> <td style="text-align: center;">0.30 m</td> </tr> </tbody> </table> | Standard compass | Steering compass | 0.30 m | 0.30 m |
| Standard compass  | Steering compass   |                  |                  |        |        |
| 0.30 m  | 0.30 m   |                  |                  |        |        |

# TABLE OF CONTENTS

---

|   |             |
|---|-------------|
| <b>FOREWARD .....</b>   | <b>v</b>    |
| <b>SYSTEM CONFIGURATION .....</b>                               | <b>vi</b>   |
| <b>EQUIPMENT LIST .....</b>                                     | <b>vii</b>  |
| <b>1. MOUNTING .....</b>  | <b>1</b>    |
| 1.1 Bottom Discrimination Sounder.....                          | 1           |
| 1.2 Transducer 520-5PSD, 520-5MSD .....                         | 2           |
| 1.2.1 Mounting location.....                                    | 2           |
| 1.2.2 Acceptable mounting locations .....                       | 3           |
| 1.2.3 Installation Procedure .....                              | 3           |
| 1.3 Transducer 525-5PWD (transom mount).....                    | 4           |
| 1.3.1 Installation for flat hulls .....                         | 5           |
| 1.3.2 Installation for deep-V hulls .....                       | 5           |
| 1.3.3 Transducer preparation .....                              | 6           |
| 1.4 Optional Water Temperature Sensor ST-02MSB, ST-02PSB.....   | 6           |
| 1.5 Optional Temperature Sensors .....                          | 7           |
| 1.5.1 Transom mount temperature sensor T-02MTB .....            | 7           |
| 1.5.2 Thru-hill temperature sensor T-02MSB, T-03MSB .....       | 7           |
| 1.6 Optional Triducers.....                                     | 9           |
| 1.6.1 Thru-hull triducer 525STID-MSD .....                      | 9           |
| 1.6.2 Transom route triducer 525STID-PWD.....                   | 9           |
| <b>2. WIRING .....</b>  | <b>14</b>   |
| 2.1 Connections .....   | 14          |
| 2.2 Optional Temperature/Speed Sensor, Temperature Sensor ..... | 15          |
| 2.3 Wiring Optional 1 kW Transducer .....                       | 16          |
| <b>3. INITIAL SETTINGS, OPERATION.....</b>                      | <b>18</b>   |
| 3.1 MODE SW.....  | 18          |
| 3.2 Operation Check (LED).....                                  | 19          |
| <b>4. MAINTENANCE .....</b>                                     | <b>20</b>   |
| 4.1 Maintenance.....  | 20          |
| 4.2 Replacing the fuse .....                                    | 21          |
| <b>SPECIFICATIONS .....</b>                                     | <b>SP-1</b> |
| <b>PACKING LIST .....</b>                                       | <b>A-1</b>  |
| <b>OUTLINE DRAWING .....</b>                                    | <b>D-1</b>  |
| <b>INTERCONNECTION DIAGRAM .....</b>                            | <b>S-1</b>  |

# FOREWARD

---

## **A Word to the Owner of the BBDS1**

Congratulations on your choice of the BBSD1 Bottom Discrimination Sounder. We are confident you will see why the FURUNO name has become synonymous with quality and reliability.

Since 1948, FURUNO Electric Company has enjoyed an enviable reputation for innovative and dependable marine electronics equipment. This dedication to excellence is furthered by our extensive global network of agents and dealers.

Your equipment is designed and constructed to meet the rigorous demands of the marine environment. However, no machine can perform its intended function unless properly operated and maintained. Please carefully read and follow the operation and maintenance procedures set forth in this manual.

Thank you for considering and purchasing FURUNO.

We would appreciate feedback from you, the end-user, about whether we are achieving our purposes.

## **Features:**

The BBDS1 features the following:

- Onboard bottom discrimination capability to assist with fishing.
- Displays fish icons which allow the user to easily discern the actual size of fish (ACCU-FISH™).

## **Caution when operating:**

Please keep the following in mind when using the Bottom Discrimination Sounder:

- The BBDS1 is for use with NavNet 3D (MFD8/12/BB) and NavNet TZtouch (TZT9/14).
- Use at a depth of 5 m - 100 m.
- Use a ship speed of 10 kt or less.
- Enter the ship's draft value via the NavNet 3D/TZtouch.
- To show a consistent display of the actual bottom, set the range display of the fish finder screen to "auto".

# SYSTEM CONFIGURATION

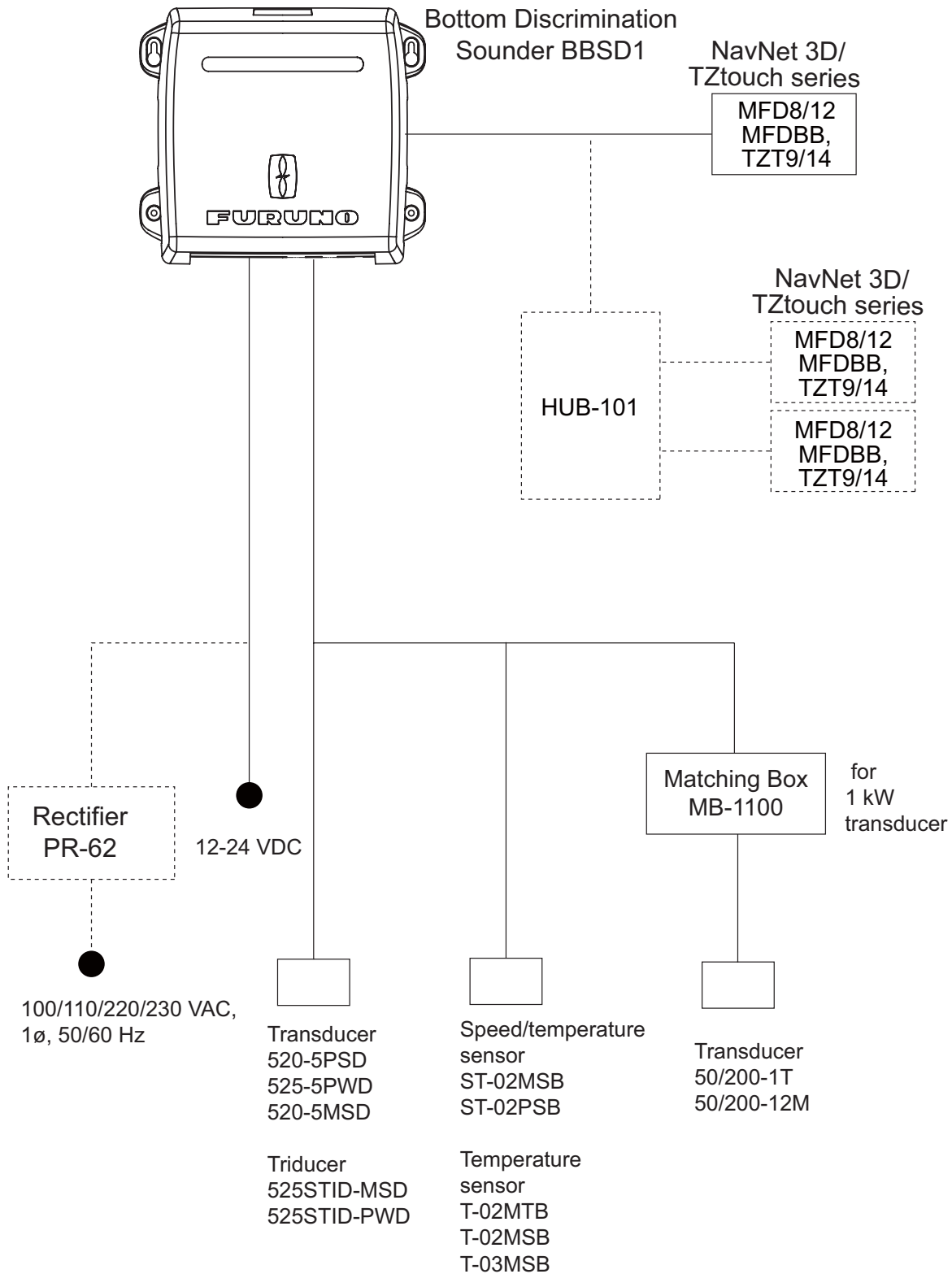

\*: HUB-101 may be connected to 3 sets of MFB8/12/MFDBB

# EQUIPMENT LIST

## Standard supply

| Name                          | Type       | Code No.    | Qty   | Remarks          |
|-------------------------------|------------|-------------|-------|------------------|
| Bottom Discrimination Sounder | BBDS1      | -           | 1     |                  |
| Spare Parts                   | SP02-05201 | 001-007-860 | 1 set | Fuse             |
| Installation Materials        | CP02-08700 | 000-017-040 | 1 set | See Packing List |

## Optional supply

| Name                         | Type          | Code No.       | Remarks                             |
|------------------------------|---------------|----------------|-------------------------------------|
| Matching Box                 | MB-1100       | 000-041-353    | For 1 kW                            |
| Cable Assy                   | MOD-Z072-020+ | 000-167-175-10 | 2 m LAN cable                       |
|                              | MOD-Z072-100+ | 000-167-177-10 | 10 m LAN cable                      |
| Triducer                     | 525STID-MSD   | 000-011-783    | Thru-hull mount, metal              |
|                              | 525STID-PWD   | 000-011-784    | Transom mount, resin                |
| Transducer                   | 520-5PSD      | 000-015-204    | Thru-hull mount, resin              |
|                              | 520-5PWD      | 000-146-966    | Transom mount, resin                |
|                              | 520-5MSD      | 000-015-212    | Thru-hull mount, metal              |
|                              | 50/200-1T     | 000-015-170    | 10 m, 1 kW                          |
|                              | 50/200-12M    | 000-015-171    | 10 m, 1 kW                          |
| Speed/<br>Temperature sensor | ST-02MSB      | 000-137-986    | Thru-hull mount, metal              |
|                              | ST-02PSB      | 000-137-987    | Thru-hull mount, resin              |
| Temperature sensor           | T-02MTB       | 000-040-026    | Transom mount                       |
|                              | T-02MSB       | 000-040-040    | Thru-hull mount                     |
|                              | T-03MSB       | 000-040-027    | Thru-hull mount                     |
| Cable Assy.                  | 02S4147       | 000-141-082    | For Speed/Temp sensor, Temp. sensor |
| Rectifier                    | PR-62         | 000-013-484    | 100 V AC                            |
|                              |               | 000-013-485    | 110 V AC                            |
|                              |               | 000-013-486    | 220 V AC                            |
|                              |               | 000-013-487    | 230 V AC                            |



# 1. MOUNTING

## 1.1 Bottom Discrimination Sounder

### ! CAUTION

Do not apply paint, rust protection, etc. to coated surface parts of the unit. These may damage the coated surface areas.

Be especially careful not to apply chemicals to the coated connectors.

The Bottom Discrimination Sounder can be installed on a desktop, deck or on a bulkhead. When selecting a mounting location for the Bottom Discrimination Sounder, keep the following in mind:

- Locate the unit away from areas where rain and splash can occur.
- The temperature and humidity should be moderate and stable.
- Locate the unit away from exhaust pipes and vents.
- Locate the unit where shock and vibration are minimal.
- The mounting location should be well ventilated.
- Keep the unit away from electromagnetic field-generating equipment such as motors and generators.
- Leave slack in cables for maintenance and servicing ease.
- A magnetic compass will be affected if the unit is placed too close to it. Observe the compass safe distances noted in the safety instructions to prevent disturbance to the magnetic compass.
- Fasten the Bottom Discrimination Sounder to the mounting location with four self-tapping screws (4×20, supplied). Fasten as specified by the drawing at the end of this book. If fastening to an upright wall or bulkhead, mount the unit vertically, not sideways.

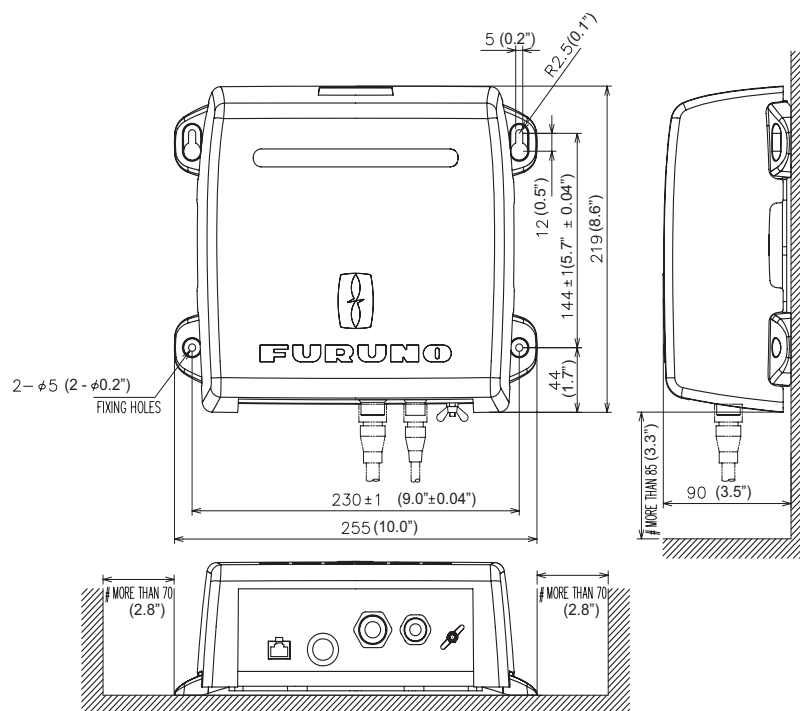

## 1.2 Transducer 520-5PSD, 520-5MSD

### 1.2.1 Mounting location

The performance of this sounder is directly related to the mounting location of the transducer, especially for high-speed cruising. The installation should be planned in advance, keeping the standard cable length and the following factors in mind:

- When the boat has a keel, the transducer should be at least 15-30 cm (5.9" - 11.8") away from it. Typical thru-hull mountings are shown in the figure on the next page.
- Air bubbles and turbulence caused by movement of the boat seriously degrade the sounding capability of the transducer. The transducer should, therefore, be located in a position where water flow is the smoothest. Noise from the propellers also adversely affects performance and the transducer should not be mounted nearby. The lifting strakes are notorious for creating acoustic noise, and these must be avoided by keeping the transducer inboard of them.
- The transducer must always remain submerged, even when the boat is rolling, pitching or up on a plane at high speed.
- A practical choice would be somewhere between 1/3 and 1/2 of the boat's length from the stern. For planing hulls, a practical location is generally rather far astern, so that the transducer is always in water regardless of the planing attitude

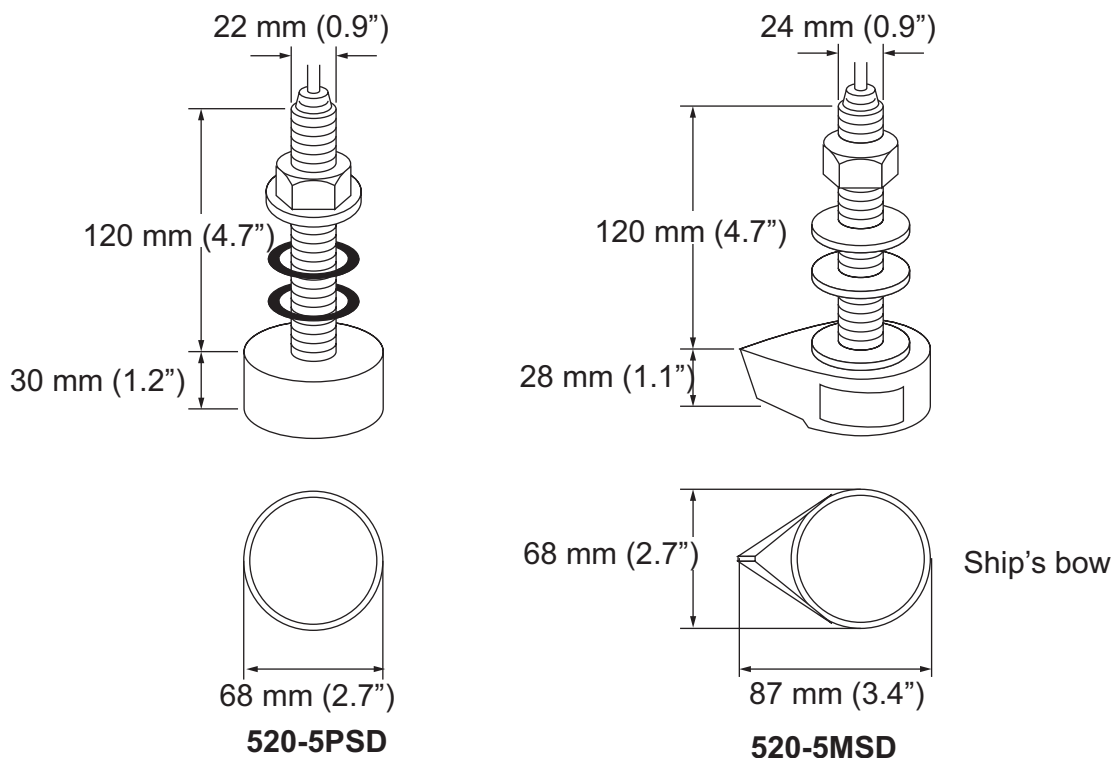

## 1. MOUNTING

### 1.2.2 Acceptable mounting locations

#### Deep V-hull

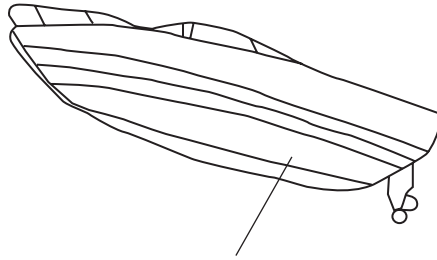

- \* Position 1/2 to 1/3 length of the hull from stern.
- \* 15-30 cm from keel line (inside first lifting strakes).

#### High speed V-planning hull

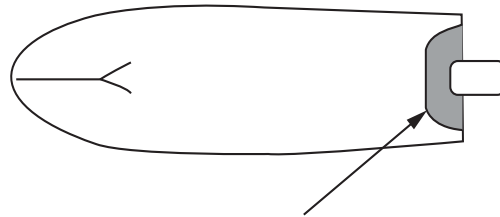
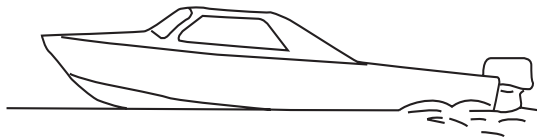

- \* Within the submerged bottom area
- \* Deadrise angle within 15°

### 1.2.3 Installation Procedure

1. With the boat hauled out of the water, mark the location selected for mounting the transducer on the bottom of the hull. If the hull is not level within 15 degrees in any direction, fairing blocks made out of teak should be used between the transducer and hull, both inside and outside, to keep the transducer face parallel with the water line. Fabricate the fairing block as shown be-

low and make the entire surface as smooth as possible to provide an undisturbed flow of water around the transducer.

The fairing block should be smaller than the transducer itself to provide a channel to divert turbulent water around the sides of the transducer rather than over its face.

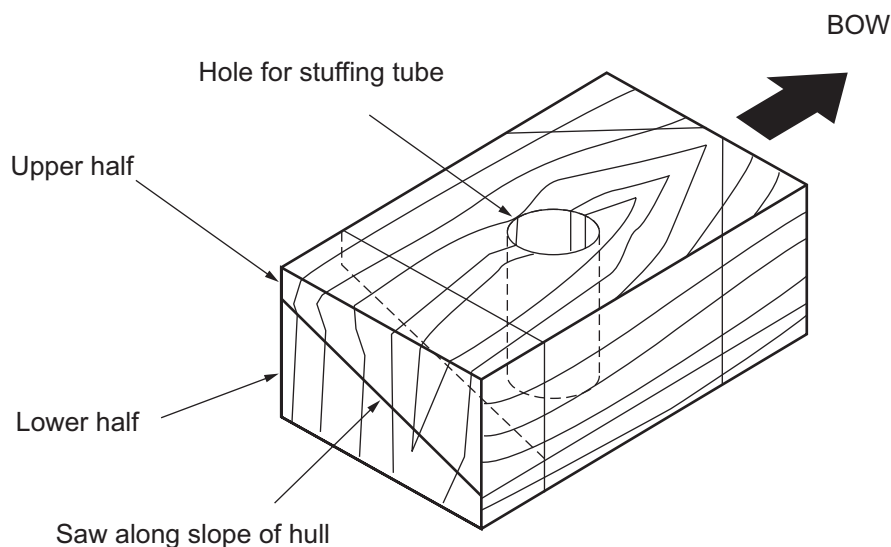

2. Drill a hole just large enough to pass the threaded stuffing tube of the transducer through the hull, making sure it is drilled vertically.
3. Apply a sufficient amount of high quality caulking compound to the top surface of the transducer, around the threads of the stuffing tube and inside the mounting hole (and fairing blocks if used) to ensure watertight mounting.
4. Mount the transducer and fairing blocks and tighten the locking nuts. Be sure that the transducer is properly oriented and its working face is parallel to the water line.

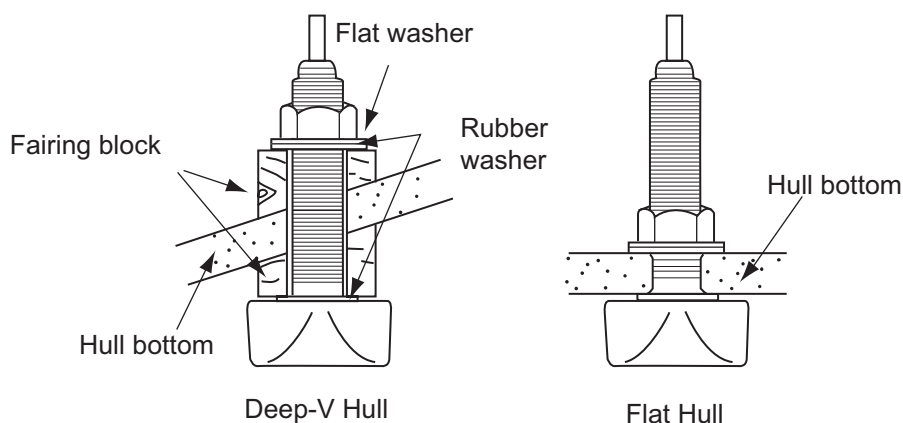

**Note:** Do not over-stress the stuffing tube and locking nuts through excessive tightening, since the wood block will swell when the boat is placed in the water. It is suggested that the nut be tightened lightly at installation and retightened several days after the boat has been launched.

### 1.3 Transducer 525-5PWD (transom mount)

This type of mounting is very commonly employed for outboard motor boats. Do not use this method on an inboard motor boat because turbulence is created by the propeller ahead of the transducer.

There are two methods of installation: flush with hull (for flat hulls) and projecting from hull (for deep V-hulls).

## 1. MOUNTING

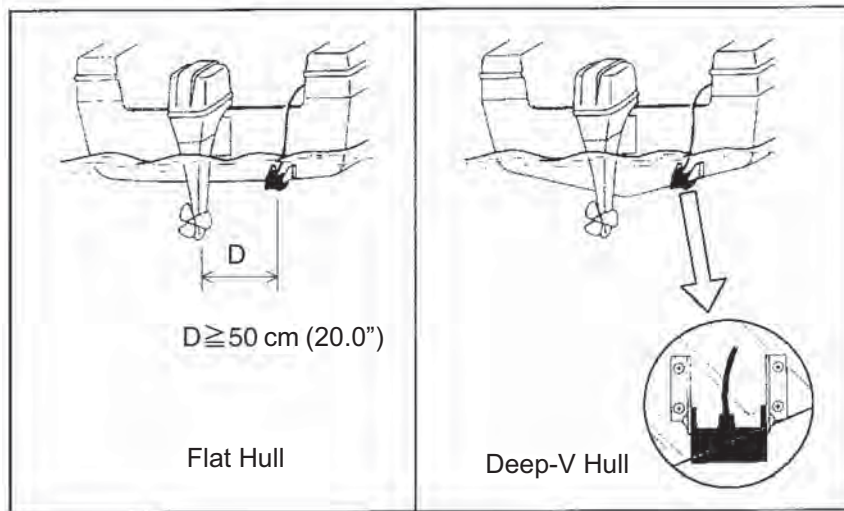

### 1.3.1 Installation for flat hulls

A suitable mounting location is at least 50 cm (20.0") away from the engine and where the water flow is smooth.

1. Drill four pilot holes in the mounting location.
2. Attach the transducer to the bracket with self-tapping screws (supplied).
3. Adjust the transducer position so the transducer faces right to the seabed.

**Note:** If necessary, to improve water flow and minimize air bubbles staying on the transducer face, incline the transducer about 5 degrees at the rear. This may require a certain amount of experimentation for fine tuning at high cruising speeds.

4. Fill the gap between the wedge front of the transducer and transom with epoxy material to eliminate any air spaces, and affix tape as shown.

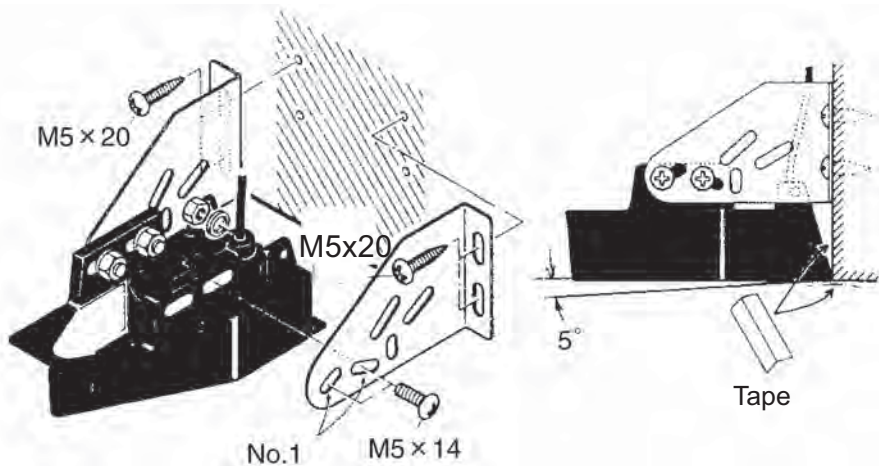

### 1.3.2 Installation for deep-V hulls

This method is employed on deep-V hulls and provides good performance because the effects of air bubbles are minimal. Install the transducer parallel with water surface; not flush with hull. If the boat is placed on a trailer care must be taken not to damage the transducer when the boat is hauled out of the water and put on the trailer.

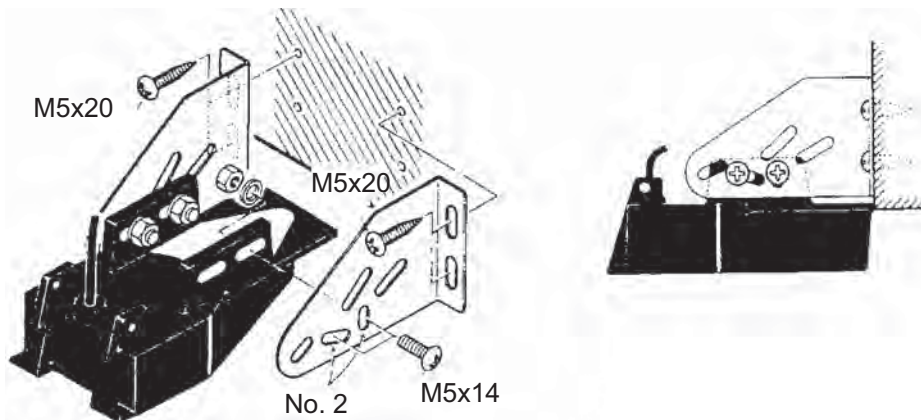

### 1.3.3 Transducer preparation

Before putting the boat in water, wipe the face of the transducer thoroughly with a detergent liquid soap. This will lessen the time necessary for the transducer to have good contact with the water. Otherwise the time required for complete "saturation" will be longer, and the performance will be reduced.

**Note:** Do not paint the transducer surface. Performance will be affected.

## 1.4 Optional Water Temperature Sensor ST-02MSB, ST-02PSB

Select a suitable mounting location considering the following points:

- Select a mid-boat flat position. The sensor does not have to be installed perfectly perpendicular. The sensor must not be damaged in dry-docking operation.
- Select a place apart from equipment generating heat.
- Select a place in the forward direction viewing from the drain hole, to allow for circulation of cooling water.
- Select a place free from vibration.

### **Procedure**

1. Dry-dock the boat.
2. Make a hole of approx. 51 mm (2.0") in diameter in the mounting location.
3. Unfasten locknut and remove the sensor section.
4. Apply high-grade silicone sealant to the flange of the sensor.
5. Pass the sensor casing through the hole.
6. Face the notch on the sensor casing and tighten the locknut.
7. Set the sensor section to the sensor casing and tighten the locknut.
8. Launch the boat and check for water leakage around the sensor.

## 1. MOUNTING

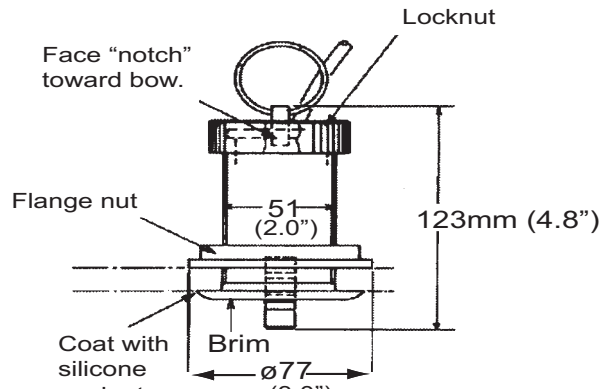

## 1.5 Optional Temperature Sensors

### 1.5.1 Transom mount temperature sensor T-02MTB

- Fix the cable at a convenient location with cable clamp.
- When the cable is led in through the transom board, make a hole of approx. 17 mm (0.7") in diameter to pass the connector. After passing the cable, fill the hole with a sealing compound.

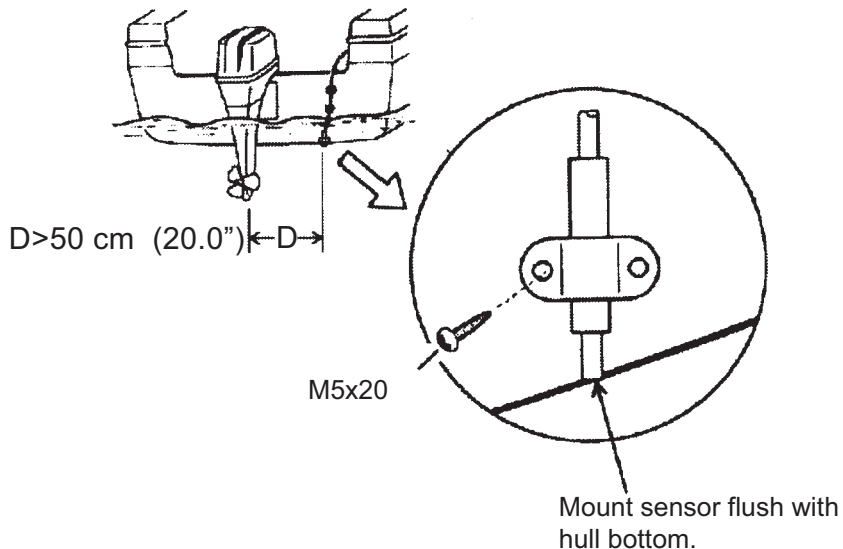

### 1.5.2 Thru-hull temperature sensor T-02MSB, T-03MSB

Select a suitable mounting location considering the following points:

- Select a mid-boat flat position. The sensor does not have to be installed perfectly perpendicular. However, the location should not be such that the transducer may be damaged when the boat is dry-docked.
- Locate away from equipment which gives off heat.
- Locate away from drain pipes.
- Select a location where vibration is minimal.

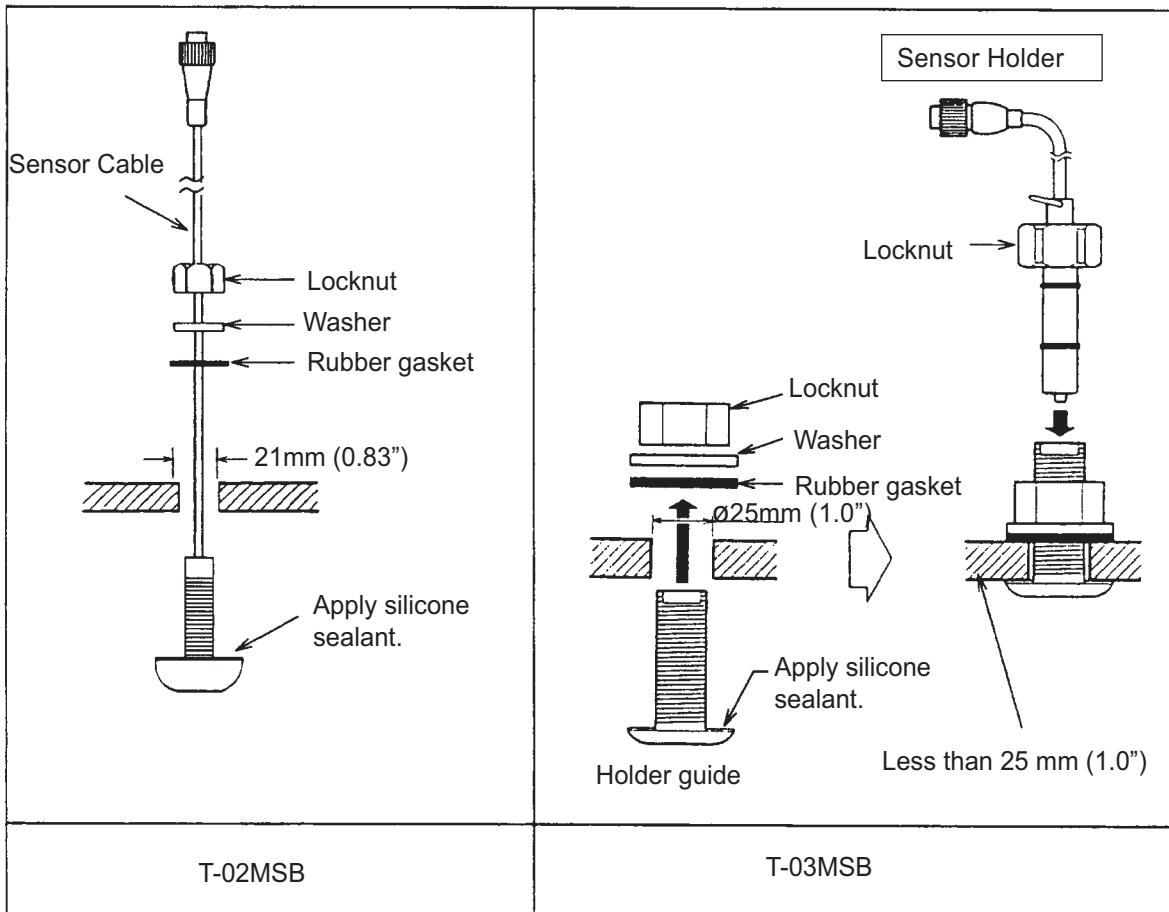

How to install:

1. Drill a 21 mm (0.83") hole in the ship's bottom.
2. Feed the cable up from under the ship's bottom.
3. Insert the cable through the rubber gasket, washer, and locknut, in that order.
4. Apply high quality silicone sealant to the the surface of the flange, and affix the sensor with the locknut (do not exceed a torque of 59 Nm).
5. After launching the ship, check that the area is free from water leakage.

How to install:

1. Drill a 25 mm (1.0") hole in the ship's bottom.
2. Coat the holder guise with a high quality silicone sealant, and feed the holder guide up through the ship's bottom.
3. Place the the rubber gasket, washer, and locknut, onto the holder guide (from the top down), in that order.
4. Place the sensor holder onto the holder guide, then affix with the nut.
5. After launching the ship, check that the area is free from water leakage.



## 1.6 Optional Triducers

### 1.6.1 Thru-hull triducer 525STID-MSD

See section 1.4 for how to install the 525STID-MSD.

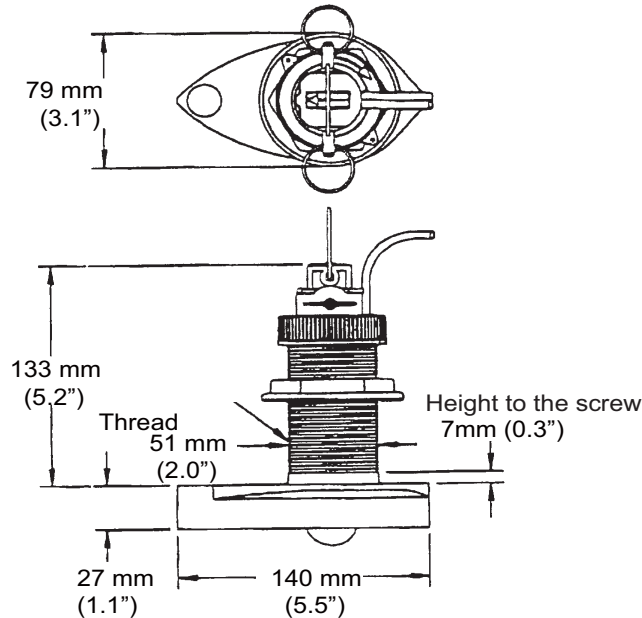

### 1.6.2 Transom route triducer 525STID-PWD

|   |
|---|
|  <b>CAUTION</b>  |
| Do not install the triducer in the following locations:   |
| <ul style="list-style-type: none"><li>• Near any water drain or vent</li><li>• Near overhangs, braces, or behind fixtures</li><li>• Near any unstable area of the ship's bottom</li><li>• Near any areas with peeling paint</li></ul> |
| Do not install the triducer where it can be a hindrance during any of the following times:  |
| <ul style="list-style-type: none"><li>• When pulling a trailer</li><li>• When launching</li><li>• When being towed</li><li>• When ship is in drydock</li></ul>  |

#### **Mounting location**

To ensure the best performance, the sensor must be submerged in aeration-free and turbulence-free water. Mount the sensor close to the centerline of the boat. On slower heavier displacement hulls, positioning it farther from the centerline is acceptable.

Allow adequate space above the bracket for it to release and rotate the sensor upward.

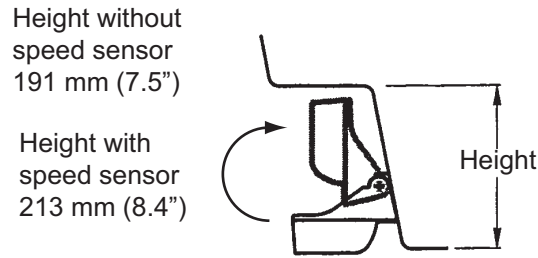

**Note 1:** Do not mount the sensor in an area of turbulence or bubbles: near water intake or discharge openings; behind strakes, struts, fittings, or hull irregularities; behind eroding paint (an indication of turbulence).

**Note 2:** Avoid mounting the sensor where the boat may be supported during trailering, launching, hauling, and storage.

**Note 3:** For single drive boat, mount on the starboard side at least 75 mm (3.0") beyond the swing radius of the propeller.

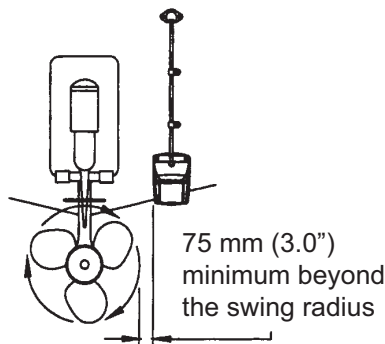

**Note 4:** For twin drive boat, mount between the drives.

**Installation of Bracket**

1. Cut out the installation template (enclosed with transducer) along the dotted line.
2. At the selected location, position the template, so the arrow at the bottom is aligned with the bottom edge of the transom. Being sure the template is parallel to the waterline, tape it in place.

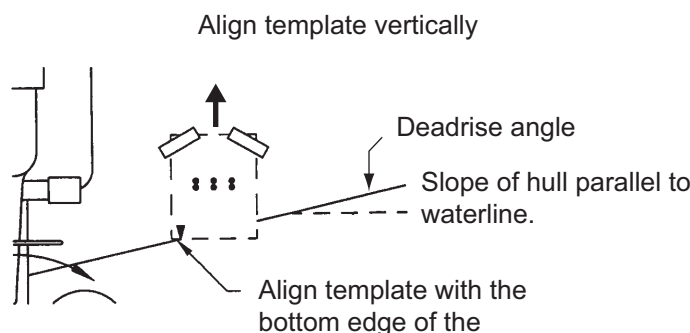

Warning: Always wear safety goggles and a dust mask.

3. Using a 4 mm, #23, or 9/64" bit, drill three holes 22 mm (0.9") deep at the locations indicated. To prevent drilling too deeply, wrap masking tape around the bit 22 mm (0.9") from the point. Fiberglass hull: Minimize surface cracking by chamfering the gelcoat. If a chamfer bit or countersink bit is not available, start drilling with a 6mm or 1/4" bit to a depth of 1 mm (0.04")

## 1. MOUNTING

4. If you know your transom angle, the bracket is designed for a standard 13° transom angle. **11°-18° angle:** No shim is required. Skip to step 3 in "Adjusting".  
**Other angles:** The shim is required. Skip to step 2 in "Adjusting". If you do not know the transom angle, temporarily attach the bracket and sensor to the transom to determine if the plastic shim is needed.
5. Using the three #10 x 1-1/4" self-tapping screws, temporarily screw the bracket to the hull. DO NOT tighten the screws completely at this time. Follow the step 1-4 in "Attaching the sensor to the bracket", before proceeding with "Adjusting".

### **Attaching the sensor to the bracket**

1. If the retaining cover near the top of the bracket is closed, open it by depressing the latch and rotating the cover downward.

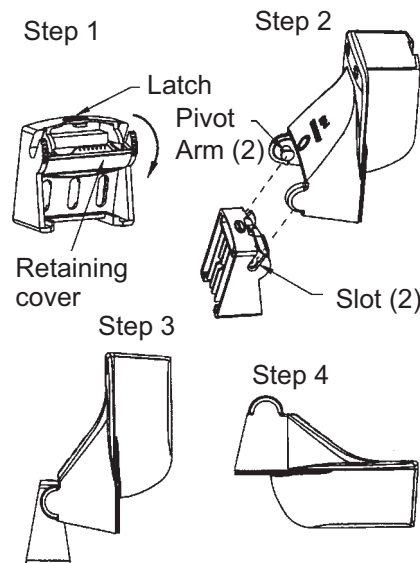

2. Insert the sensor's pivot arms into the slots near the top of the bracket.
3. Maintain pressure until the pivot arms click into place.
4. Rotate the sensor downward until the bottom snaps into the bracket.
5. Close the retaining cover to prevent the accidental release of the sensor when the boat is underway.

### **Adjusting**

1. Using a straight edge, align the underside of the sensor relative to the underside of the hull. The stern of the sensor should be 1-3 mm (1/16-1/8") below the bow of the sensor or parallel to the bottom of the hull.  
**Note:** Do not position the bow of the sensor lower than the stern because aeration will occur.
2. To adjust the sensor's angle relative to the hull, use the tapered plastic shim provided. If the bracket has been temporarily fastened to the transom, remove it. Key the shim in place on the back of the bracket.

2°-10° transom angle (stepped transom and jet boats): Position the shim with the tapered end down.

19°-22° transom angle (small aluminum and fiberglass boats): Position the shim with the tapered end up.

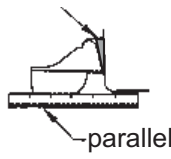
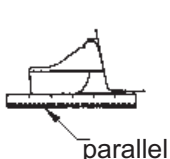
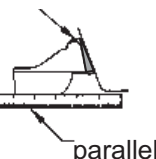
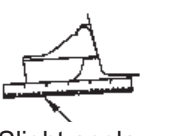
| 2°-10°<br>transom angle   | 11° transom<br>angle   | 19°-22°<br>transom angle  |
|---|--|---|
| Shim with<br>taper up<br>    | No shim<br> | Shim with<br>taper down<br> |
| 12°-18°<br>transom angle  |  |   |
| <br>Slight angle,<br>no shim |  |   |

- If the bracket has been temporarily fastened to the transom, remove it. Apply a marine sealant to the threads of the three #10 x 1-1/4" self-tapping screws to prevent water seeping into the transom. Screw the bracket to the hull. Do not tighten the screws completely at this time.
- Repeat step 1 to ensure that the angle of the sensor is correct.  
**Note:** Do not position the sensor farther into the water than necessary to avoid increasing drag, spray, and water noise and reducing boat speed.
- Using the vertical adjustment space on the bracket slots, slide the sensor up or down to provide a projection of 3 mm (1/8"). Tighten the screws.

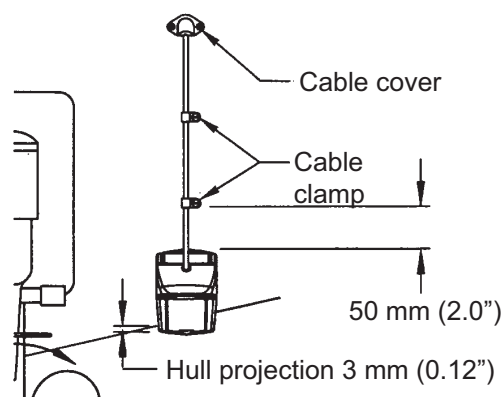

### Cable routing

Route the sensor cable over the transom, through a drain hole, or through a new hole drilled in the transom above the waterline.

Never cut the cable or remove the connector; this will void the warranty. Always wear safety goggles and a dust mask.

## 1. MOUNTING

1. If a hole must be drilled, choose a location well above the waterline. Check for obstructions such as trim tabs, pumps, or wiring inside the hull. Mark the location with a pencil. Drill a hole through the transom using a 19 mm or 3/4" bit (to accommodate the connector).
2. Route the cable over or through the transom.
3. On the outside of the hull secure the cable against the transom using the cable clamps. Position a cable clamp 50 mm (2.0") above the bracket and mark the mounting hole with a pencil.
4. Position the second cable clamp halfway between the first clamp and the cable hole. Mark this mounting hole.
5. If a hole has been drilled in the transom, open the appropriate slot in the transom cable cover. Position the cover over the cable where it enters the hull. Mark the two mounting holes.
6. At each of the marked locations, use a 3 mm or 1/8" bit to drill a hole 10 mm (0.4") deep. To prevent drilling too deeply, wrap masking tape around the bit 10 mm (0.4") from the point.
7. Apply marine sealant to the threads of the #6 x 1/2" self-tapping screw to prevent water from seeping into the transom. If you have drilled a hole through the transom, apply marine sealant to the space around the cable where it passes through the transom.
8. Position the two cable clamps and fasten them in place. If used, push the cable cover over the cable and screw it in place.
9. Route the cable to the instrument being careful not to tear the cable jacket when passing it through the bulkhead(s) and other parts of the boat. To reduce electrical interference, separate the sensor cable from other electrical wiring and "noise" sources. Coil any excess cable and secure it in place with zip-ties to prevent damage.

# 2. WIRING

## 2.1 Connections

Connect the MFD8/12/BB, TZT9/14, power cable and transducer cable as shown in the figure below.

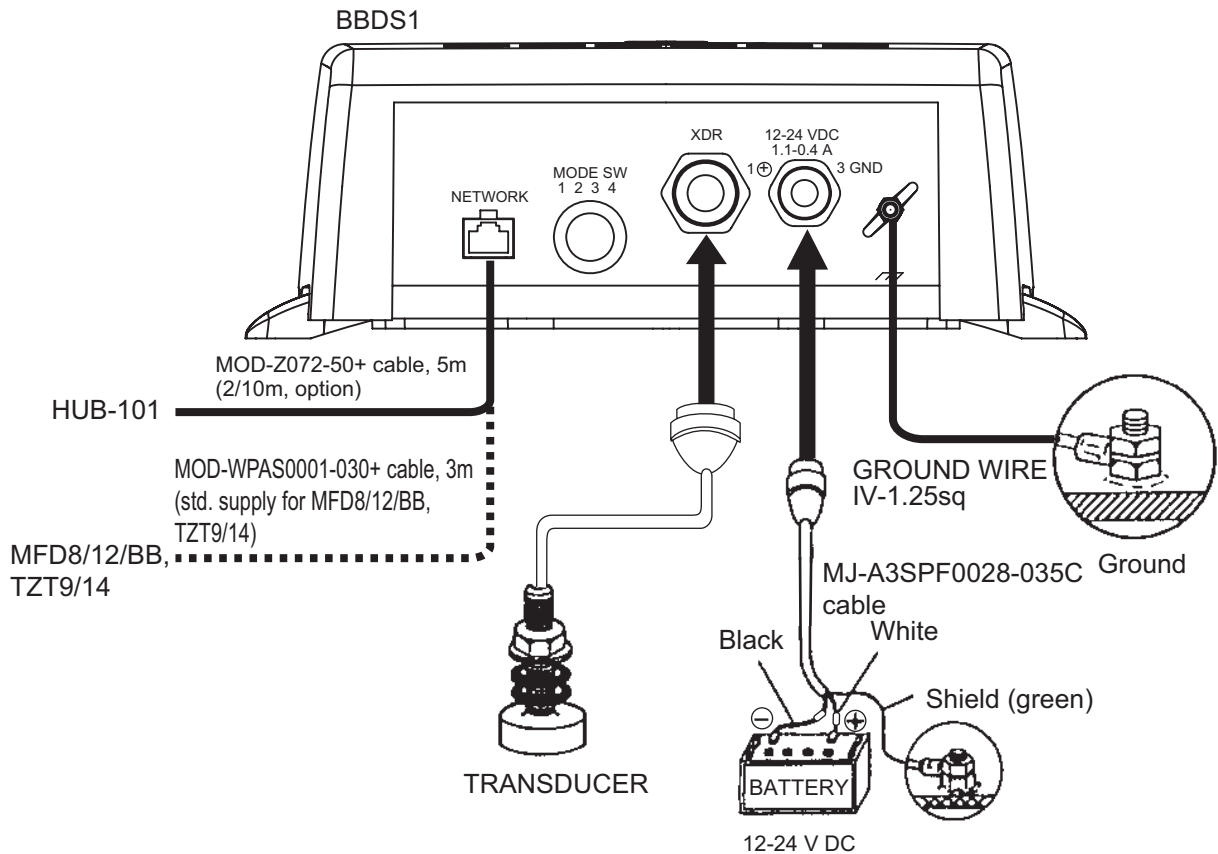

### Ground

Connect the ground wire (1.25sq) to ship's ground to prevent interference to the picture. Shorten the ground wire as much as possible. For FRP vessels, install a ground plate that measures about 20 cm by 30 cm (8" x 12") on the outside of the hull bottom to provide a ground point.

|   |   |
|---|---|
| <b>⚠ CAUTION</b>  |   |
|  | <b>Ground the equipment to prevent mutual interference.</b> |

**Note:** Use a "closed-type" lug  to make the ground connection at the Bottom Discrimination Sounder.

2. WIRING

**External KP**

Consult with your dealer if connection of an external KP is required to reduce interference from another transducer.

**2.2 Optional Temperature/Speed Sensor, Temperature Sensor.**

Connect the temperature/speed sensor or temperature sensor to the XDR port with the cable asy. (Type: 02S4147, Code No.: 000-141-082, option).

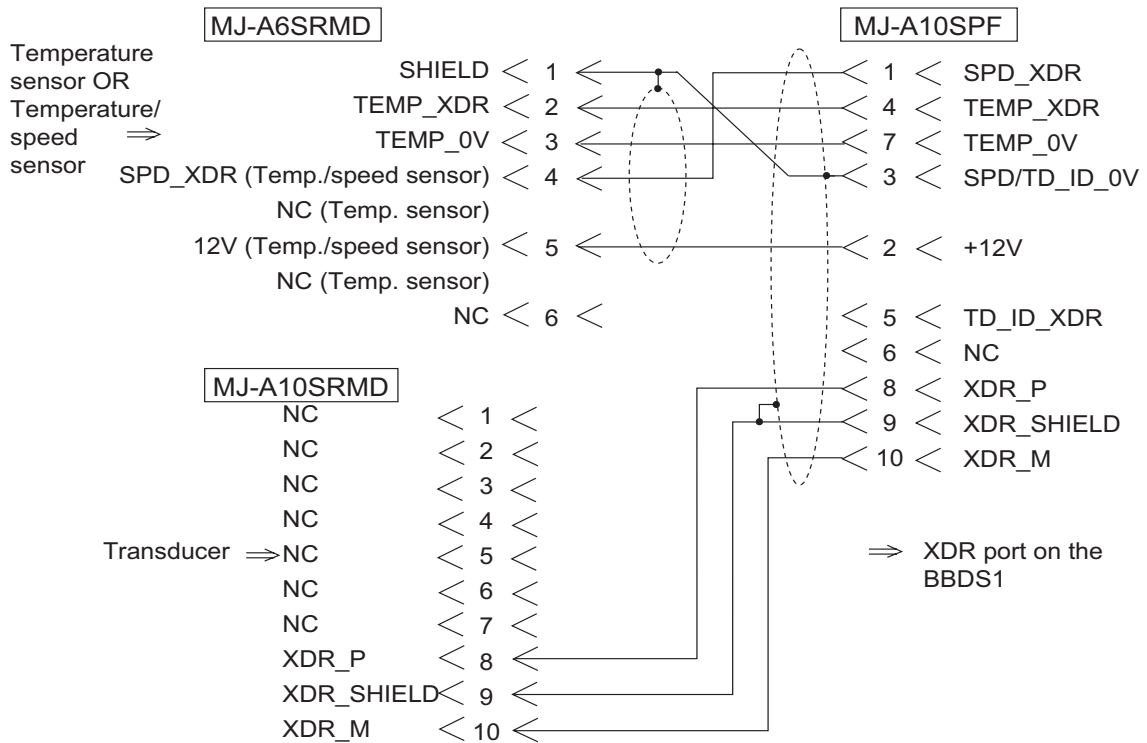

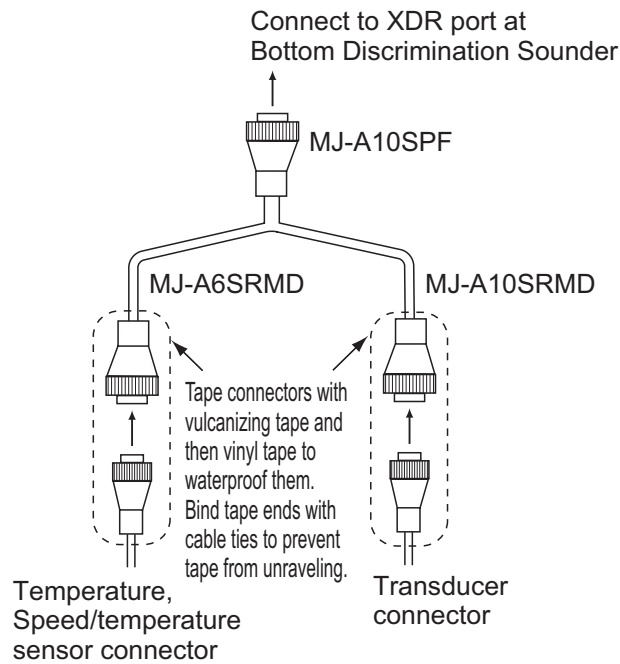

### 2.3 Wiring Optional 1 kW Transducer

To connect optional transducer 50/200-1T or 50/200-12M, the optional Matching Box MB-1100 is required.

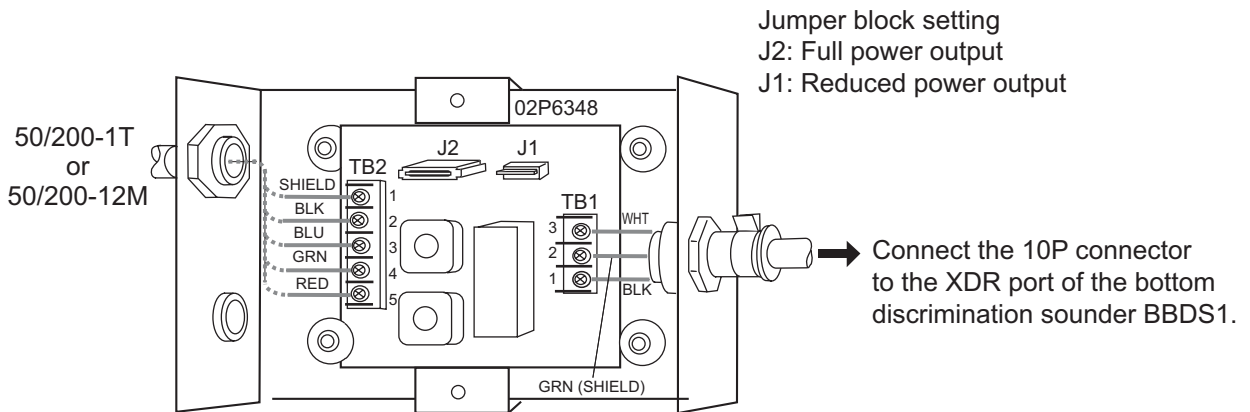



## 2. WIRING

### **Matching Box: Type MB-1100, Code Number 000-041-353**

| Name         | Type         | Code no.       | Qty | Remarks   |
|--------------|--------------|----------------|-----|---|
| Matching Box | MB-1100      | 000-041-000    | 1   | Cable w/10P connector supplied for connection to Bottom Discrimination Sounder. |
| Crimp-on Lug | FV1.25-3 Red | 000-166-756-10 | 6   | 1 spare supplied  |
| Cord Lock    | NC-1         | 000-168-230-10 | 1   | For use with separate transducer. Do not use.                                   |

### **Fabrication of transducer cable**

Fabricate the transducer cable as illustrated below to connect it to the Matching Box.

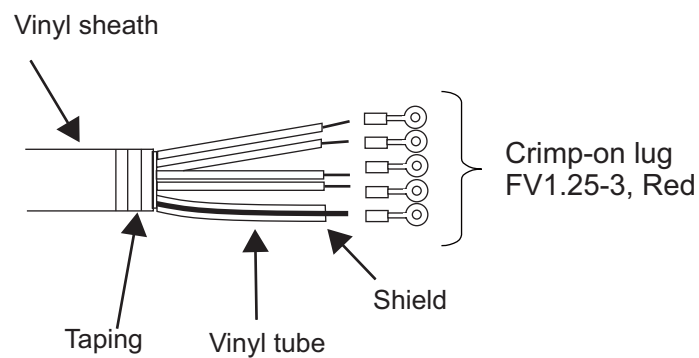

# 3. INITIAL SETTINGS, OPERATION

After connecting the NavNet 3D/TZtouch, select the transmission power from the Navnet 3D/TZtouch startup wizard. Refer to the respective Instruction Manual.

## 3.1 MODE SW

The MODE switch is shipped for connection to the NavNet 3D; all switches are OFF. For the TZtouch, remove the rubber cap to access the switch. Set the switches as shown below, with a plastic screwdriver or the like.

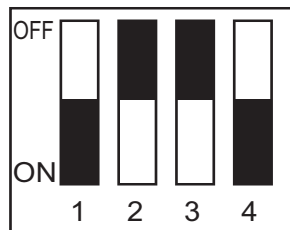
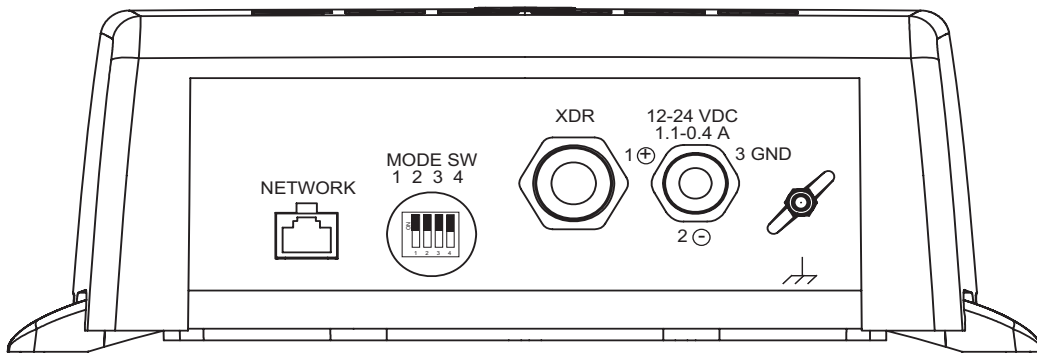

#1: ON  
#2: OFF  
#3: OFF  
#4: ON

NavNet TZtouch MODE switch settings

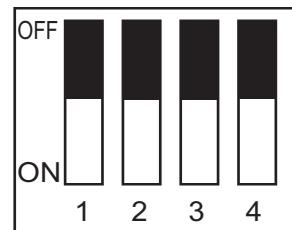

ALL OFF

NavNet 3D MODE switch settings

| SW No.              | Function, description                      | Setting content   |
|---------------------|--|---|
| 1<br>(Default: OFF) | Power from Navnet equipment                | OFF: Sounder powered on/off by NavNet equipment.<br>ON: Sounder not powered on/off by Navnet equipment. |
| 2<br>(Default: OFF) | IP number<br>(Currently no use)            | OFF: IP0<br>ON: IP1   |
| 3<br>(Default: OFF) | Factory testing                            | OFF: Testing OFF ON: Testing ON   |
| 4<br>(Default: OFF) | Automatic IP setting<br>(Currently no use) | OFF: Automatic IP enabled ON: Automatic IP disabled   |

For connection to NavNet 3D, all switches must be OFF. Make sure to confirm the switch settings.

### 3.2 Operation Check (LED)

The BBDS1 is powered on and off according to the NavNet series it is connected to. **NavNet TZ-touch**: Powered on and off from the mains switchboard.

**Navnet 3D**: Powered on and off from a display unit.

The LED on the Bottom Discrimination Sounder lights or flashes according to equipment state, as described in the table below.

| LED state                   | Meaning   |
|-----------------------------|---|
| Lighting continuously       | NavNet equipment is not showing the sounder display, or sounder is not connected to NavNet equipment. |
| Flashing every two seconds  | Normal operation  |
| Flashing every four seconds | Factory test mode   |

\* The LED lights for approximately 20 seconds after turning on the power while the equipment is being initialized.

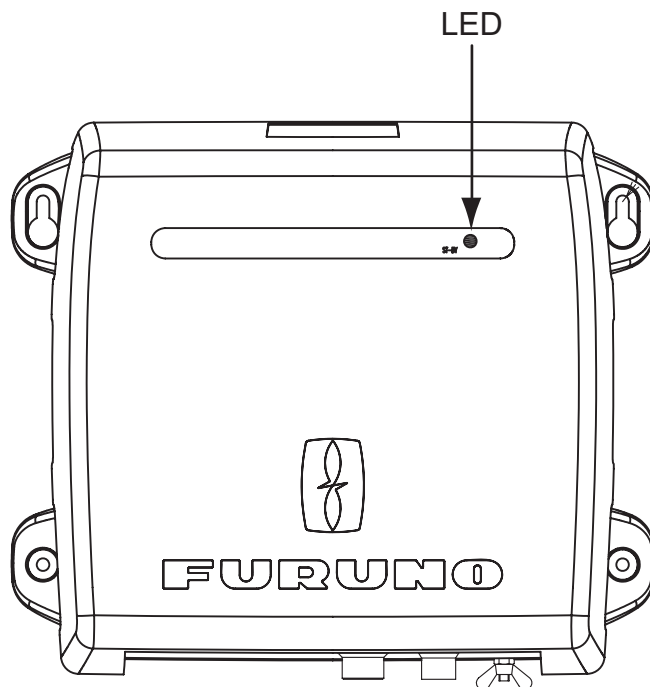

# 4. MAINTENANCE

---

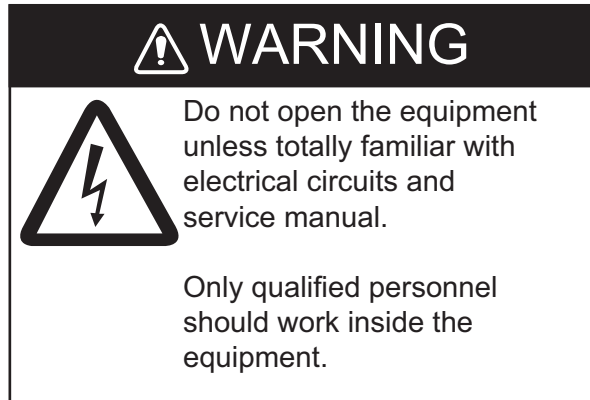

## 4.1 Maintenance

Regular maintenance is essential for good performance. Check the items listed in the table below monthly to help keep your equipment in good shape for years to come.

| Item   | Action  | Performance Schedule          |
|--|---|-------------------------------|
| Transducer cable                                     | Check that cable is tightly fastened and is not damaged. Replace if damaged.  | Once a month                  |
| Power cable, transducer cable plus                   | Check that they are tightly fastened and not damaged. Refasten if necessary. Replace if damaged.  | Once a month                  |
| Ground   | Check for corrosion. Clean if necessary.  | Once a month                  |
| Power supply voltage                                 | Check voltage. If out of rating correct problem.  | Once a month                  |
| Cleaning the Bottom Discrimination Sounder's cabinet | Dust or dirt on the cabinet may be removed with a dry cloth. Do not use chemical-based cleaners to clean the cabinet; they can remove paint and markings.   | Once a month                  |
| Transducer   | Marine life on the transducer face will result in a gradual decrease in sensitivity. Check the transducer face for cleanliness each time the boat is dry-docked. Carefully remove any marine life with a piece of wood or fine-grade sandpaper. | Every time boat is dry docked |

## 4.2 Replacing the fuse

The two 3 A fuses (Type: FGBO-A 125V 3A PBF, Code No. 000-155-850-10) in the snap-in fuse holder on the power cable protect the equipment from equipment fault and reverse polarity of the ship's mains. If the equipment cannot be powered, a fuse may have blown. Find out the cause for blown fuse before replacing a fuse. If a fuse blows again after replacement, contact a FURUNO agent or dealer for advice.



### WARNING

Use the proper fuse.

Use of a wrong fuse can result in damage to the equipment or cause fire.

**SPECIFICATIONS OF BOTTOM DISCRIMINATION SOUNDER  
BBDS1**

**1 GENERAL**

- 1.1 Output power 600 W/ 1 kW rms nominal, 1 kW requires optional MB-1100
- 1.2 TX frequency 50 kHz or 200 kHz, 50/200 kHz alternating
- 1.3 Amplifier type Wide dynamic linear amp (double superheterodyne)
- 1.4 Measuring function Fish length measurement, Bottom discrimination, Heave compensation\*, Frequency auto-setting from transducer-ID data (specified transducer)  
\*: optional sensor required
- 1.5 Network protocol Ethernet 100BASE-TX
- 1.6 Depth range and Pulse Repetition Rate

| Range (m) | PRR (/min.) |
|-----------|-------------|
| 2         | 3000        |
| 5         | 3000        |
| 10        | 1990        |
| 40        | 485         |
| 100       | 195         |
| 200       | 95          |
| 400       | 65          |
| 1200      | 34          |

**2 POWER SUPPLY**

12-24 VDC: 1.1-0.4 A (at 1 kW output)

**3 ENVIRONMENTAL CONDITION**

- 3.1 Ambient temperature -15°C to +55°C
- 3.2 Relative humidity 93% at 40°C
- 3.3 Degree of protection IP20
- 3.4 Vibration IEC 60945-4

**4 UNIT COLOR**

N3.0

# PACKING LIST

02GH-X-9851 -2 1/1

BBDS1-J/E

A-1

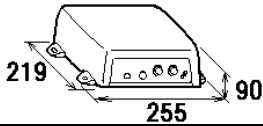
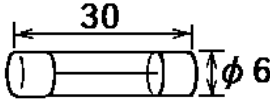
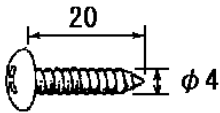
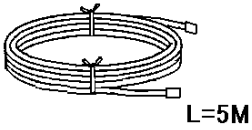
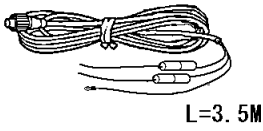
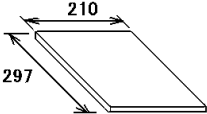
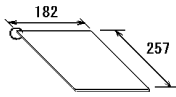
| NAME                          | OUTLINE   | DESCRIPTION/CODE No. | Q' TY |
|-------------------------------|---|----------------------|-------|
| <b>UNIT</b>                   |   |                      |       |
| BOTTOM DISCRIMINATION SOUNDER |    | BBDS1                | 1     |
|                               |   | 000-017-039-00       |       |
| <b>SPARE PARTS</b>            |   |                      |       |
| <b>SP02-05201</b>             |   |                      |       |
| GLASS TUBE FUSE               |    | FGBO-A 125V 3A PBF   | 2     |
|                               |   | 000-155-850-10       |       |
| <b>INSTALLATION MATERIALS</b> |   |                      |       |
| <b>CP02-08700</b>             |   |                      |       |
| SELF-TAPPING SCREW            |    | 4X20 SUS304          | 4     |
|                               |   | 000-158-850-10       |       |
| LAN CABLE ASSEMBLY            |    | MOD-Z072-050+        | 1     |
|                               |   | 000-167-176-10       |       |
| POWER CABLE ASSY.             |   | MJ-A3SPF0028-035C    | 1     |
|                               |   | 000-164-952-10       |       |
| <b>DOCUMENT</b>               |   |                      |       |
| OPERATOR'S MANUAL             |  | OM*-20380-*          | 1     |
|                               |   | 000-173-390-1* **    |       |
| OPERATOR'S GUIDE (MLG)        |  | MLG-20380-*          | 1     |
|                               |   | 000-173-392-1*       |       |

CODE NUMBER ENDING WITH "\*\*" INDICATES THE CODE NUMBER OF REPRESENTATIVE MATERIAL.

TWO TYPES AND CODES MAY BE LISTED FOR AN ITEM. THE LOWER PRODUCT MAY BE SHIPPED IN PLACE OF THE UPPER PRODUCT. QUALITY IS THE SAME.

(DIMENSIONS IN DRAWING FOR REFERENCE ONLY.)

表 1 TABLE 1

| 寸法区分 (mm)<br>DIMENSION | 公差 (mm)<br>TOLERANCE |
|------------------------|----------------------|
| $L \leq 50$            | $\pm 1.5$            |
| $50 < L \leq 100$      | $\pm 2.5$            |
| $100 < L \leq 500$     | $\pm 3$              |

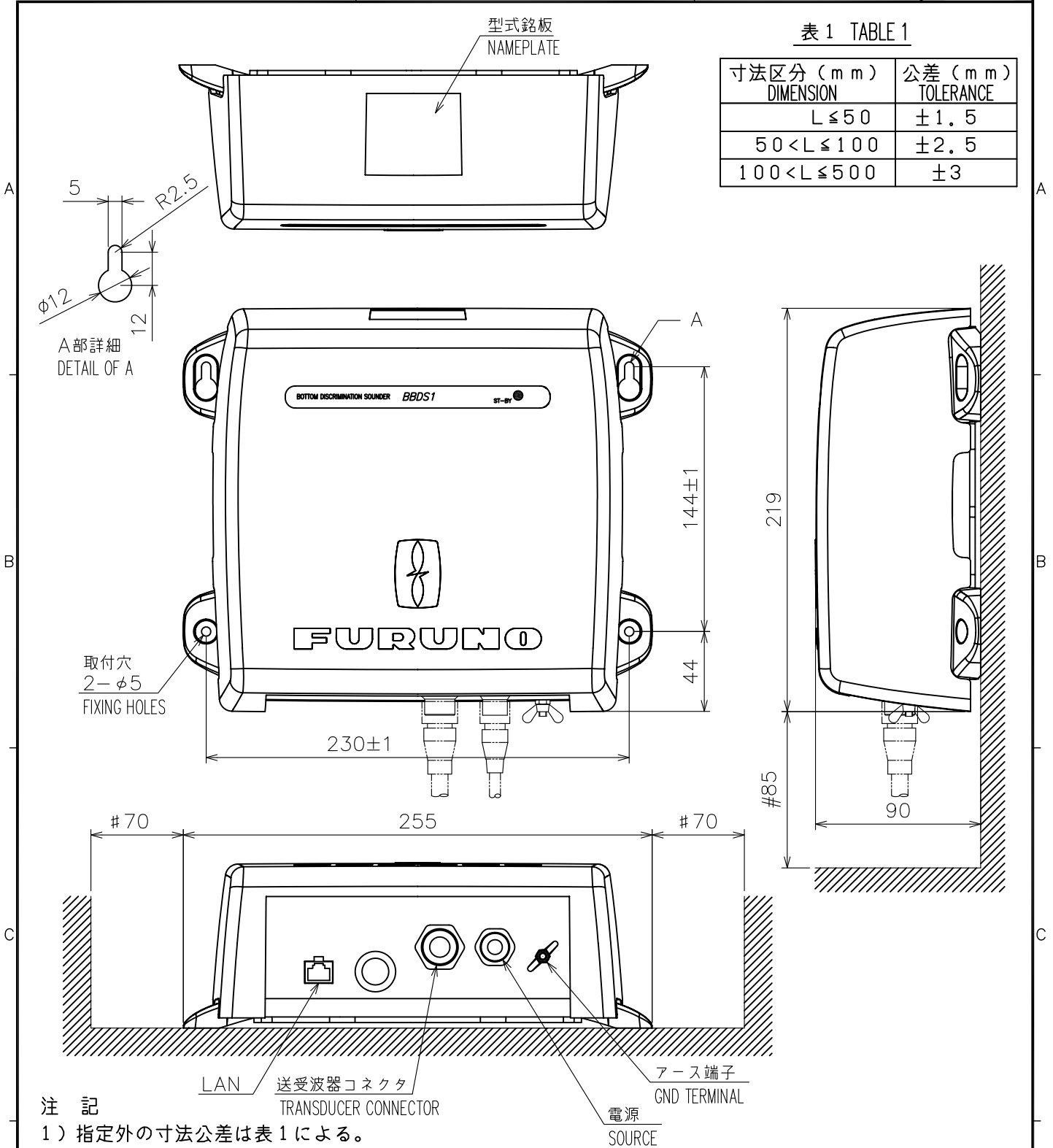

注 記

- 1) 指定外の寸法公差は表 1 による。
- 2) # 印寸法は最小サービス空間寸法とする。
- 3) 取付ネジはトラスタップピンネジ呼び径4X20を使用のこと。

NOTE

1. TABLE 1 INDICATES TOLERANCE OF DIMENSIONS WHICH IS NOT SPECIFIED.
2. #: MINIMUM SERVICE CLEARANCE.
3. USE TAPPING SCREWS  $\phi 4 \times 20$  FOR FIXING THE UNIT.

|                                    |                              |                                       |
|------------------------------------|------------------------------|---------------------------------------|
| DRAWN<br>2/Mar/2010 T.YAMASAKI     |                              | TITLE<br>BBDS1                        |
| CHECKED<br>2/Mar/2010 T.TAKAHASHI  |                              | 名称<br>底質判別魚探                          |
| APPROVED<br>8/Mar/2010 Y.NISHIYAMA | BBDS1                        | 外寸図                                   |
| SCALE<br>1/3                       | MASS<br>1.2 $\pm 10\%$<br>kg | NAME<br>BOTTOM DISCRIMINATION SOUNDER |
| DWG. No.<br>C2038-G01-A            | REF. No.<br>02-162-100G-0    | OUTLINE DRAWING                       |



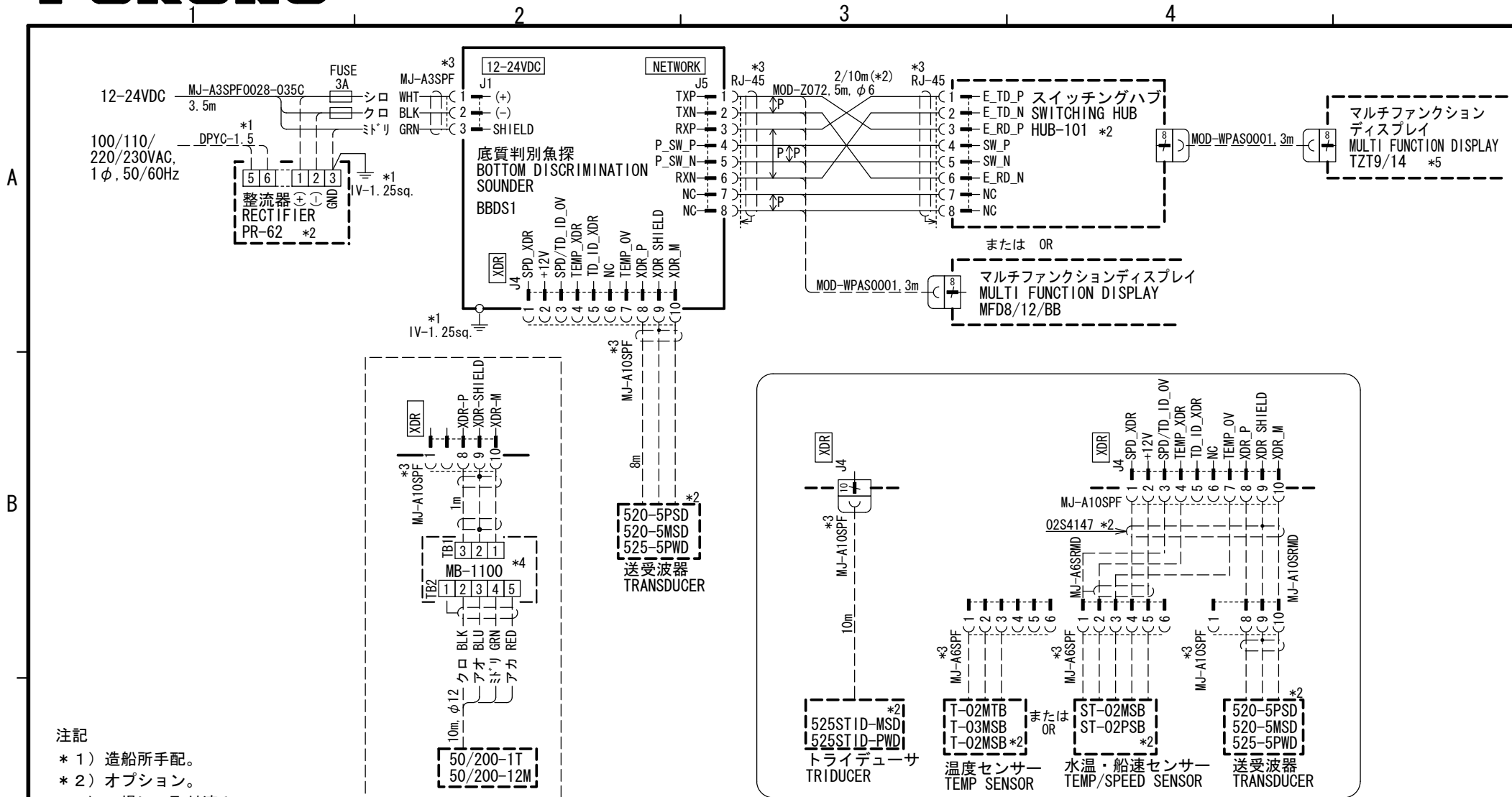

注記

- \* 1) 造船所手配。
- \* 2) オプション。
- \* 3) 工場にて取付済み。
- \* 4) BBDS1のジャンパー設定変更が必要。
- \* 5) BBDS1のDIPスイッチ設定変更が必要。

NOTE

- \*1: SHIPYARD SUPPLY.
- \*2: OPTION.
- \*3: FITTED AT FACTORY.
- \*4: CHANGE JUMPER SETTING OF BBDS1.
- \*5: CHANGE DIP SWITCH SETTING OF BBDS1.

|                                      |                           |                                       |
|--------------------------------------|---------------------------|---------------------------------------|
| DRAWN<br>20/Feb/2012 T. YAMASAKI     |                           | TITLE<br>BBDS1                        |
| CHECKED<br>20/Feb/2012 H. MAKI       |                           | 名称<br>底質判別魚探                          |
| APPROVED<br>20/Feb/2012 Y. NISHIYAMA |                           | 相互結線図                                 |
| SCALE<br>MASS kg                     |                           | NAME<br>BOTTOM DISCRIMINATION SOUNDER |
| DWG. No.<br>C2038-C01- E             | REF. No.<br>02-162-1003-0 | INTERCONNECTION DIAGRAM               |

# FURUNO Worldwide Warranty for Pleasure Boats (Except North America)

This warranty is valid for products manufactured by Furuno Electric Co. (hereafter FURUNO) and installed on a pleasure boat. Any web based purchases that are imported into other countries by anyone other than a FURUNO certified dealer may not comply with local standards. FURUNO strongly recommends against importing these products from international websites as the imported product may not work correctly and may interfere with other electronic devices. The imported product may also be in breach of the local laws and mandated technical requirements. Products imported into other countries as described previously shall not be eligible for local warranty service.

For products purchased outside of your country please contact the national distributor of Furuno products in the country where purchased.

This warranty is in addition to the customer's statutory legal rights.

## 1. Terms and Conditions of Warranty

FURUNO guarantees that each new FURUNO product is the result of quality materials and workmanship. The warranty is valid for a period of 2 years (24 months) from the date of the invoice, or the date of commissioning of the product by the installing certified dealer.

## 2. FURUNO Standard Warranty

The FURUNO standard warranty covers spare parts and labour costs associated with a warranty claim, provided that the product is returned to a FURUNO national distributor by prepaid carrier.

The FURUNO standard warranty includes:

- Repair at a FURUNO national distributor
- All spare parts for the repair
- Cost for economical shipment to customer

## 3. FURUNO Onboard Warranty

If the product was installed/commissioned and registered by a certified FURUNO dealer, the customer has the right to the onboard warranty.

The FURUNO onboard warranty includes

- Free shipping of the necessary parts
- Labour: Normal working hours only
- Travel time: Up to a maximum of two (2) hours
- Travel distance: Up to a maximum of one hundred and sixty (160) KM by car for the complete journey

## 4. Warranty Registration

For the Standard Warranty - presentation of product with serial number (8 digits serial number, 1234-5678) is sufficient. Otherwise, the invoice with serial number, name and stamp of the dealer and date of purchase is shown.

For the Onboard Warranty your FURUNO certified dealer will take care of all registrations.

## 5. Warranty Claims

For the Standard Warranty - simply send the defective product together with the invoice to a FURUNO national distributor. For the Onboard Warranty – contact a FURUNO national distributor or a certified dealer. Give the product's serial number and describe the problem as accurately as possible.

Warranty repairs carried out by companies/persons other than a FURUNO national distributor or a certified dealer is not covered by this warranty.

## 6. Warranty Limitations

When a claim is made, FURUNO has a right to choose whether to repair the product or replace it.

The FURUNO warranty is only valid if the product was correctly installed and used. Therefore, it is necessary for the customer to comply with the instructions in the handbook. Problems which result from not complying with the instruction manual are not covered by the warranty.

FURUNO is not liable for any damage caused to the vessel by using a FURUNO product.

The following are excluded from this warranty:

- a. Second-hand product
- b. Underwater unit such as transducer and hull unit
- c. Routine maintenance, alignment and calibration services.
- d. Replacement of consumable parts such as fuses, lamps, recording papers, drive belts, cables, protective covers and batteries.
- d. Magnetron and MIC with more than 1000 transmitting hours or older than 12 months, whichever comes first.
- e. Costs associated with the replacement of a transducer (e.g. Crane, docking or diver etc.).
- f. Sea trial, test and evaluation or other demonstrations.
- g. Products repaired or altered by anyone other than the FURUNO national distributor or an authorized dealer.
- h. Products on which the serial number is altered, defaced or removed.
- i. Problems resulting from an accident, negligence, misuse, improper installation, vandalism or water penetration.
- j. Damage resulting from a force majeure or other natural catastrophe or calamity.
- k. Damage from shipping or transit.
- l. Software updates, except when deemed necessary and warrantable by FURUNO.
- m. Overtime, extra labour outside of normal hours such as weekend/holiday, and travel costs above the 160 KM allowance
- n. Operator familiarization and orientation.

FURUNO Electric Company, March 1, 2011

## **FURUNO Warranty for North America**

FURUNO U.S.A., Limited Warranty provides a twenty-four (24) months LABOR and twenty-four (24) months PARTS warranty on products from the date of installation or purchase by the original owner. Products or components that are represented as being waterproof are guaranteed to be waterproof only for, and within the limits, of the warranty period stated above. The warranty start date may not exceed eighteen (18) months from the original date of purchase by dealer from Furuno USA and applies to new equipment installed and operated in accordance with Furuno USA's published instructions.

Magnetrons and Microwave devices will be warranted for a period of 12 months from date of original equipment installation.

Furuno U.S.A., Inc. warrants each new product to be of sound material and workmanship and through its authorized dealer will exchange any parts proven to be defective in material or workmanship under normal use at no charge for a period of 24 months from the date of installation or purchase.

Furuno U.S.A., Inc., through an authorized Furuno dealer will provide labor at no cost to replace defective parts, exclusive of routine maintenance or normal adjustments, for a period of 24 months from installation date provided the work is done by Furuno U.S.A., Inc. or an AUTHORIZED Furuno dealer during normal shop hours and within a radius of 50 miles of the shop location.

A suitable proof of purchase showing date of purchase, or installation certification must be available to Furuno U.S.A., Inc., or its authorized dealer at the time of request for warranty service.

This warranty is valid for installation of products manufactured by Furuno Electric Co. (hereafter FURUNO). Any purchases from brick and mortar or web-based resellers that are imported into other countries by anyone other than a FURUNO certified dealer, agent or subsidiary may not comply with local standards. FURUNO strongly recommends against importing these products from international websites or other resellers, as the imported product may not work correctly and may interfere with other electronic devices. The imported product may also be in breach of the local laws and mandated technical requirements. Products imported into other countries, as described previously, shall not be eligible for local warranty service.

For products purchased outside of your country please contact the national distributor of Furuno products in the country where purchased.

### **WARRANTY REGISTRATION AND INFORMATION**

To register your product for warranty, as well as see the complete warranty guidelines and limitations. In order to expedite repairs, warranty service on Furuno equipment is provided through its authorized dealer network. If this is not possible or practical, please contact Furuno U.S.A., Inc. to arrange warranty service.

Furuno U.S.A., Inc. is proud to supply you with the highest quality in [Marine Electronics](#). We know you had several choices when making your selection of equipment, and from everyone at Furuno we thank you. Furuno takes great pride in customer service.