

FURUNO

OWNER'S GUIDE & INSTALLATION INSTRUCTIONS

Cavity or Welded-tank Mount: 1kW

Sealcast™ Depth Transducer

Chirp Models: CM265LH, CM265LM, CM275LHW

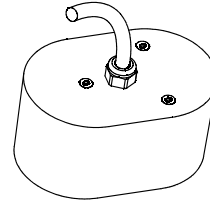

WARNING: The transducer must be professionally installed using accepted practices. The cavity or welded tank must be strong and watertight to reduce the risk of property damage, personal injury, and/or death.

Follow the precautions below for optimal product performance and to reduce the risk of property damage, personal injury, and/or death.

WARNING: Always wear safety glasses, a dust mask, and ear protection when installing.

WARNING: Use marine sealant to seal the hull and hold the transducer firmly in place. When the boat is underway, especially at high speeds, water will enter any gaps and push against the transducer with considerable force.

WARNING: A faceplate is required to secure the transducer to the hull. The bolts are an aid to installation only and must not be solely relied upon. When the boat is underway, especially at high speeds, water will push against the transducer with considerable force.

WARNING: Immediately check for leaks when the boat is placed in the water. Do not leave the boat unchecked for more than three hours. Even a small leak may allow considerable water to accumulate.

CAUTION: Always operate the transducer in water. Operating in air will allow the transducer to overheat resulting in failure.

CAUTION: Do not install in the engine compartment or other hot place. The transducer may fail if it overheats.

CAUTION: The transducer must be flush with the bottom of the hull for good performance.

CAUTION: Never pull, carry, or hold the transducer by the cable. This may sever internal connections.

CAUTION: Never strike the transducer.

CAUTION: Never power sand or pressure wash the transducer. It may weaken the structure or damage the internal components.

CAUTION: Never use solvents. Cleaners, fuel, sealants, paint, and other products may contain solvents that can damage plastic parts, especially the transducer's face.

IMPORTANT: Please read the instructions completely before proceeding with the installation. These instructions supersede any other instructions in your instrument manual if they differ.

Applications

- Cavity mounting recommended for fiberglass hulls.
- Cavity mounting recommended for high-speed boats.

Tools & Materials

NOTE: Making a fiberglass cavity in the hull, a faceplate, or a welded tank requires additional tools and materials not listed.

Safety glasses

Dust mask

Ear protection

Scissors

Masking tape

Electric drill

Drill bits and hole saws:

Pilot hole Ø 3mm or 1/8"

Cable hole large enough to accommodate the bushing

Bolt hole (3) Ø 8mm or 5/16"

Sandpaper (coarse grit 120)

Tack cloth

Marine sealant (suitable for below waterline)

Purchased nuts, bolts & washers (3)

(stainless steel, 1/4"-20 UNC threads)

Torque wrench

Grommet(s) (some installations)

Cable ties

Water-based anti-fouling coating (**mandatory in salt water**)

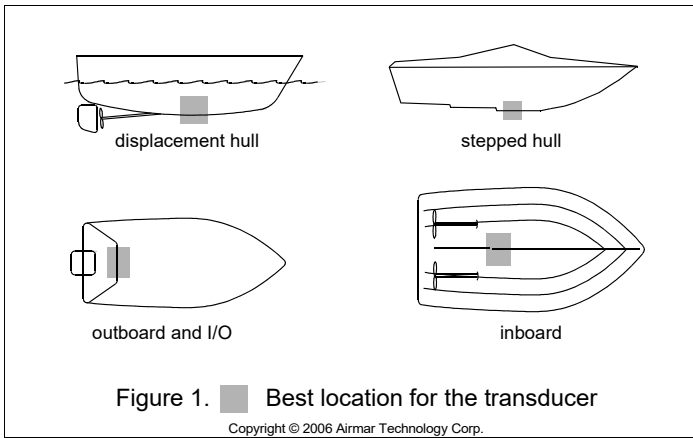

Mounting Location *Placement Guidelines*

CAUTION: Do not mount the transducer in line with or near water intake or discharge openings or behind strakes, fittings, or hull irregularities that will disturb the water flow.

CAUTION: Do not mount the transducer in line with trailer rollers or bunks that may damage the transducer's face.

Choose a Location

- Where the hull is flat or nearly flat, so the transducer beam will be aimed straight down.
- Where the water flowing under the hull is smoothest with a minimum of bubbles and turbulence (especially at high speeds).
- Where the transducer will be in contact with the water at all times.
- Where the transducer beam will not be blocked by the keel or propeller shaft(s).
- In a cool well-ventilated area away from the engine to avoid overheating.
- Away from interference caused by power and radiation sources such as: the propeller(s) and shaft(s), other machinery, other echosounders, and other cables. The lower the noise level, the higher the echosounder gain setting that can be used.
- Where there is working space inside the vessel.

Hull Types (Figure 1)

- **Displacement hull powerboats**—Locate amidships near the centerline. The side of the hull where the propeller blades are moving downward is preferred.
- **Planing hull powerboats**—Mount well aft and *well inboard of the first set of lifting strakes* to ensure that the transducer will be in contact with the water at high speeds. The side of the hull where the propeller blades are moving downward is preferred.
- **Outboard and I/O**—Mount just forward of the engine(s).
- **Inboard**—Mount well ahead of the propeller(s) and shaft(s).
- **Stepped hull**—Mount just ahead of the first step.

Installation in a Welded Tank

Each hull is different. Professionally install the transducer following accepted practices.

Installation in a Cavity *Pre-molded Cavity*

If the boat has a pre-molded cavity in the hull to receive the transducer, go to "Making a Faceplate".

Making a Cavity

1. Using the template (page 4), cut along the "cutting line for hull cavity" (outermost line). Tape it to the hull at the selected mounting location.
2. Cut a hole in the hull.

3. Create a strong watertight cavity to hold the transducer.

Making a Faceplate

A faceplate is required to ensure the transducer is held within the cavity when the boat is traveling at high speed.

1. Make a faceplate using a strong material suitable for below the waterline such as 316 stainless steel or glass-fiber reinforced epoxy FR4 or G10. The faceplate must be thick enough to fill the lip of the transducer [6mm (1/4")] after marine sealant is applied.
2. Cut the opening in the faceplate using the template supplied. Follow the "Transducer lip: cutting line for the opening in the faceplate."
3. Drill holes for the fasteners that will hold the faceplate securely to the hull. Fasteners must be suitable for below waterline.

Dry Fitting

The transducer must be flush with the bottom of the hull for good performance. *Dry fit the transducer in the cavity before installing.*

1. Position the template (page 4) within the cavity. Tape it in place.
2. Using the appropriate drill bits, drill a hole through the cavity for the cable.
3. From outside the hull, thread the transducer cable through the hole in the mounting cavity (Figure 2). Push the transducer into the cavity as far as possible.

Measure the gap between the face of transducer and the outside of the hull (as if the transducer is flush to the exterior hull surface). This will be the thickness of marine sealant that must be applied to the cable side of the transducer, plus an additional 3mm (1/8") to fill any empty spaces.

Bedding & Installing

CAUTION: Be sure the surfaces to be bedded are clean and dry.

1. To ensure that the marine sealant will adhere properly, sand the area around the hole in the hull, inside and outside. On the transducer, sand all the surfaces that will contact the hull. Sand the lip of the transducer (Figure 2). *Do not sand the face.* Remove all dust using a tack cloth. *Do not use alcohol on the transducer.*

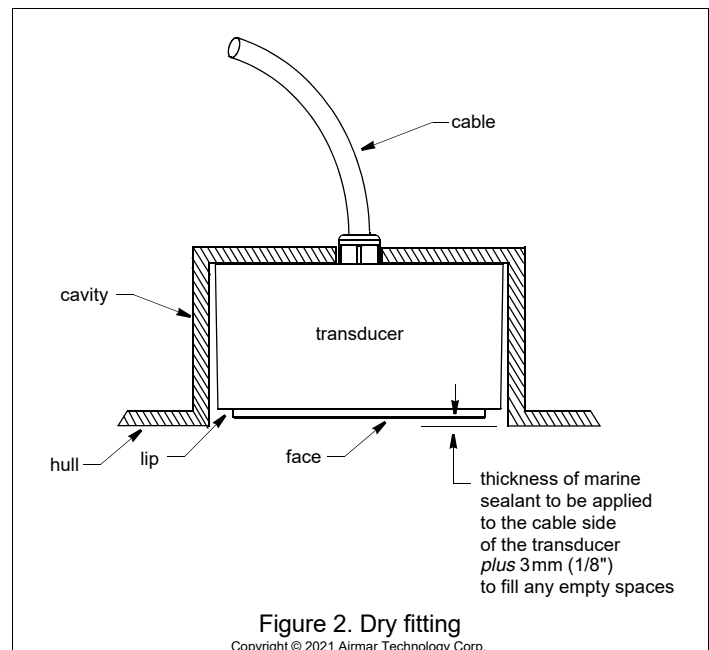

2. Apply marine sealant to the following surfaces to seal the hull and hold the transducer firmly in place (Figure 3):

- Cable side of the transducer—Apply the amount of marine sealant determined by dry fitting the transducer in the cavity, *plus an additional 3mm (1/8")*.
- Apply 6mm (1/4") of marine sealant to the transducer surfaces that will contact the cavity, *including the lip*.
- Apply 6mm (1/4") of marine sealant to the cable fittings, being sure the marine sealant extends 6mm (1/4") outside of the cavity and into the hull.
- Apply 3mm (1/8") of marine sealant to the threads of the purchased bolts.
- Apply 3mm (1/8") of marine sealant to the surface of the purchased washers that will contact the cavity.
- Apply 3mm (1/8") of marine sealant to the side of the faceplate that will contact the hull and the transducer's lip.
- Apply 3mm (1/8") of marine sealant to the fasteners that will hold the faceplate to the hull.

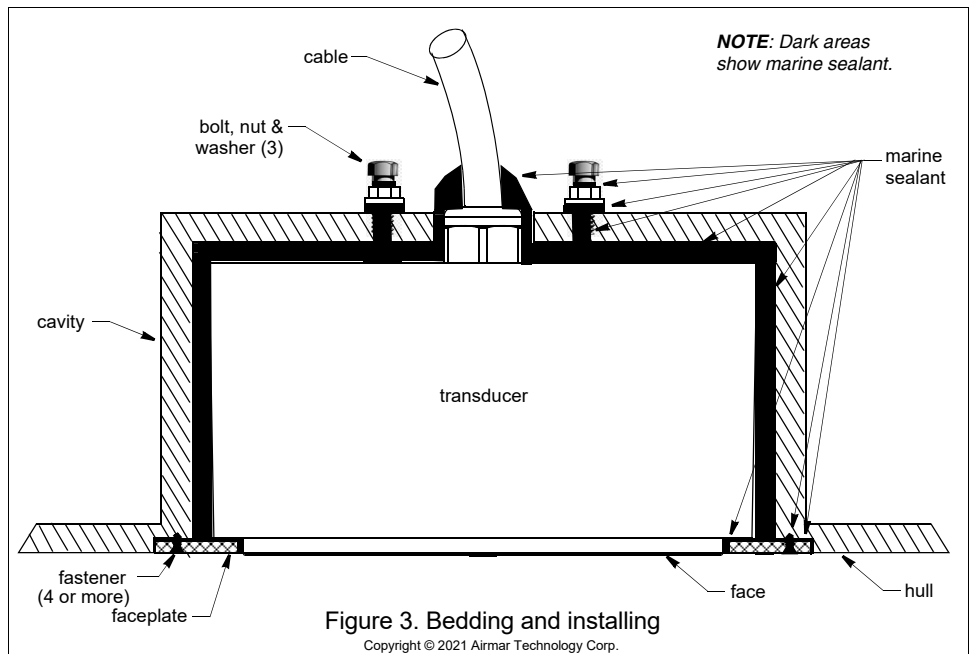

3. From outside the hull, thread the transducer cable through the hole in the mounting cavity. Push the transducer into the mounting cavity and seat it firmly within the recess. *The transducer's face must be flush with the outside of the hull for good performance.* If necessary, apply additional marine sealant to the cable side of the transducer.
4. From inside the hull, screw a nut onto each bolt. Place one washer against each nut so that the side with the sealant will be against the cavity when installed. Screw each bolt into a threaded hole in the transducer. Tighten the bolts using a torque wrench with a force not exceeding 85 in.-lb. Do not over tighten.
5. When the boat is underway, especially at high speeds, water will enter any gaps between the transducer and the hull and push against the transducer with considerable force. From outside the hull, fill any gaps between the transducer and the cavity with marine sealant.
6. Fasten the faceplate to the hull.
7. Remove the excess sealant on the outside of the hull to ensure smooth water flow under the transducer.

Cable Routing & Connecting

CAUTION: If the transducer came with a connector, do not remove it to ease cable routing. If the cable must be cut and spliced, use Airmar's splash-proof Junction Box No. 33-035 and follow the instructions provided. Removing the water-proof connector or cutting the cable, except when using water-tight junction box, will void the transducer warranty.

1. Route the cable to the echosounder being careful not to tear the cable jacket when passing it through the bulkhead(s) and other parts of the boat. Use grommets to prevent chafing. To reduce electrical interference, separate the transducer cable from other electrical wiring and the engine(s). Coil any excess cable and secure it in place with cable ties to prevent damage.
2. Refer to your echosounder owner's manual to connect the transducer to the instrument.

Checking for Leaks

When the boat is placed in the water, **immediately** check around the transducer for leaks. Note that very small leaks may not be readily observed. Do not leave the boat in the water for more than 3 hours before checking it again. If a leak is observed, repeat the installation procedure **immediately**.

Maintenance & Replacement

Anti-fouling Coating

Surfaces exposed to salt water must be covered with an anti-fouling coating. Use a water-based anti-fouling coating made for transducers only. Never use ketone based anti-fouling paint, since ketones can attack many plastics possibly damaging the transducer. Brush on anti-fouling coating every 6 months or at the beginning of each boating season.

Cleaning

Aquatic growth can accumulate rapidly on the transducer's face, reducing its performance within weeks. Clean the surface with a Scotch-Brite® scour and mild household detergent, being careful to *avoid making scratches*. If the fouling is severe, lightly wet sand it with fine grade wet/dry paper.

Transducer Replacement & Parts

The information needed to order a replacement Airmar transducer is printed on the cable tag. Do not remove this tag. When ordering, specify the part number, date, and frequency in kHz. For convenient reference, record this information near the top of page one.



