

# FURUNO

## OWNER'S GUIDE & INSTALLATION INSTRUCTIONS

### Retractable Thru-hull Depth & Temperature Transducer

Models: DT800, DT800V

**IMPORTANT:** Please read the instructions completely before proceeding with the installation. These instructions supersede any other instructions in your instrument manual if they differ.

#### CAUTION: NEVER USE SOLVENTS!

Cleaners, fuel, paint, sealants, and other products may contain strong solvents, such as acetone, which attack many plastics greatly reducing their strength.

#### Applications

- **Plastic** housing recommended for fiberglass or metal hulls only. *Never* install a plastic housing in a wood hull since swelling of the wood can possibly fracture the plastic.
- **Bronze** housing recommended for fiberglass or wood hulls. *Never* mount a bronze housing in an aluminum hull because electrolytic corrosion will occur.
- **Stainless steel** housing compatible with all hull materials. Recommended for aluminum hulls to prevent electrolytic corrosion provided the stainless steel housing is isolated from the metal hull.
- *Never* install a metal housing in a vessel with a positive ground system.

#### Tools & Materials

Water-based antifouling paint (**MANDATORY IN SALT WATER**)

Safety goggles

Dust mask

Electric drill with 10mm (3/8") or larger chuck capacity

Drill bit: 3mm or 1/8"

Hole saw: 51 mm or 2" (plastic or bronze housing)

57 mm or 2-1/4" (stainless steel housing in a metal hull)

Countersink tool (installing a flush housing)

Sandpaper

Mild household detergent or weak solvent (such as alcohol)

File (installation in a metal hull)

Marine sealant (suitable for below waterline)

Additional washer [for aluminum hull less than 6mm (1/4") thick]

Slip-joint pliers (installing a bronze housing)

Zip-ties

Installation in a cored fiberglass hull (see page 3):

Hole saw for hull interior: 60mm or 2-3/8"

Fiberglass cloth and resin

or Cylinder, wax, tape, and casting epoxy

Record the information found on the cable tag for future reference.

Part No. \_\_\_\_\_ Date \_\_\_\_\_ Frequency \_\_\_\_\_ kHz

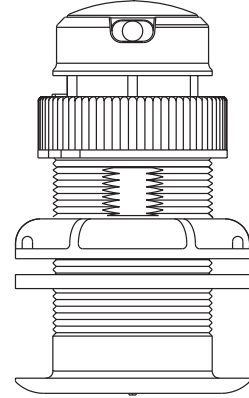

DT800  
in a plastic  
low-profile housing

#### Fairing

**Caution:** *Never* use a fairing with a plastic housing; the protruding transducer would be vulnerable to damage from impact.

#### Antifouling Paint

Aquatic growth can accumulate rapidly on the transducer's surface reducing performance within weeks. Surfaces exposed to salt water *must* be coated with antifouling paint. Use **WATER-BASED** antifouling paint only. *Never* use ketone-based paint, since ketones can attack many plastics possibly damaging the transducer.

It is easier to apply antifouling paint before installation, but allow sufficient drying time. Reapply paint every 6 months or at the beginning of each boating season. Paint the following surfaces (see Figure 1):

- Outside wall of the insert below the lower O-ring
- Exposed end of the insert
- Bore of the housing up 30mm (1-1/4")
- Exterior lip of the housing
- Blanking plug below the lower O-ring including the exposed end

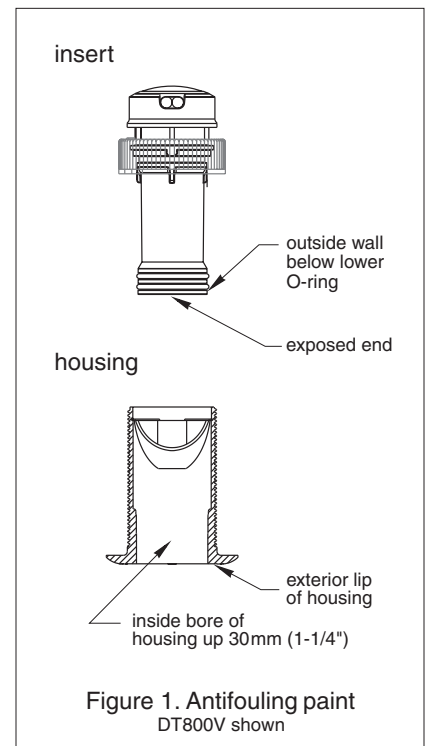

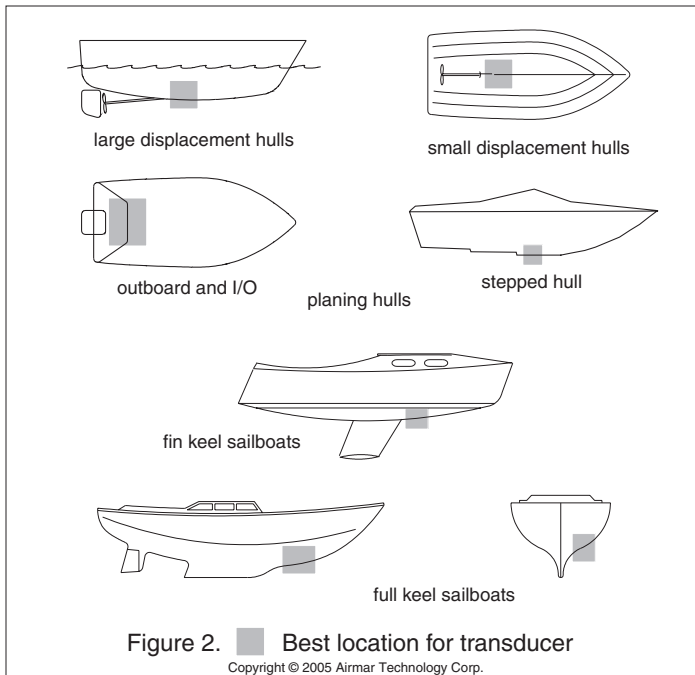

## Mounting Location

- The water flowing across the hull *must* be smooth with a minimum of bubbles and turbulence (especially at high speeds).

**Caution:** DO NOT MOUNT near water intake or discharge openings, or behind strakes, fittings, or hull irregularities.

- The transducer *must* be continuously immersed in water.
- The transducer beam *must* be unobstructed by the keel or propeller shaft(s).
- Choose a location away from interference caused by power and radiation sources such as: the propeller(s) and shaft(s), other machinery, other echosounders, and other cables. The lower the noise level, the higher the echosounder gain setting that can be used.
- Choose a location with a deadrise angle of 20° or less, so the transducer beam will be aimed at the bottom.
- Choose an accessible spot inside the vessel with adequate headroom for the height of the housing, tightening the nuts, and removing the insert. Allow a minimum of 280mm (11").

## Hull Types (see Figure 2)

- Displacement hull powerboats**—Locate amidships near the centerline. The starboard side of the hull where the propeller blades are moving downward is preferred.
- Planing hull powerboats**—Mount well aft, on or near the centerline, and *well inboard of the first set of lifting strakes* to insure that the transducer will be in contact with the water at high speeds. The starboard side of the hull where the propeller blades are moving downward is preferred.
- Outboard and I/O**—Mount just forward of the engine(s).
- Inboard**—Mount well ahead of the propeller(s) and shaft(s).
- Stepped hull**—Mount just ahead of the first step.
- Boat capable of speeds above 25kn (29MPH)**—Review the installation location and operating results of similar boats before proceeding.
- Fin keel sailboats**—Mount on or as close as possible to the centerline and forward of the fin keel 300–600mm (1–2').
- Full keel sailboats**—Locate amidships and away from the keel at the point of minimum deadrise.

## Installation

**Cored fiberglass hull**—Follow separate instructions on page 3.

### Hole Drilling

**Warning:** Always wear safety goggles and a dust mask.

- Drill a 3mm or 1/8" pilot hole from inside the hull. If there is a rib, strut or other hull irregularity near the selected mounting location, drill from the outside.
  - Using the appropriate size hole saw, cut a hole from outside the hull.  
**Flush housing**—Use a countersink tool to create a seat in the hull.
  - Sand and clean the area around the hole, inside and outside, to ensure that the sealant will adhere properly to the hull. If there is any petroleum residue inside the hull, remove it with either mild household detergent or a weak solvent (alcohol) before sanding.
- Metal hull**—Remove all burrs with a file and sandpaper.

### Bedding

**Caution:** A stainless steel housing must be isolated from a metal hull to prevent electrolytic corrosion.

Apply a 2mm (1/16") thick layer of marine sealant around the lip of the housing that contacts the hull and up the sidewall of the housing (see Figure 3). The sealant *must* extend 6mm (1/4") higher than the combined thickness of the hull, the washer(s), and

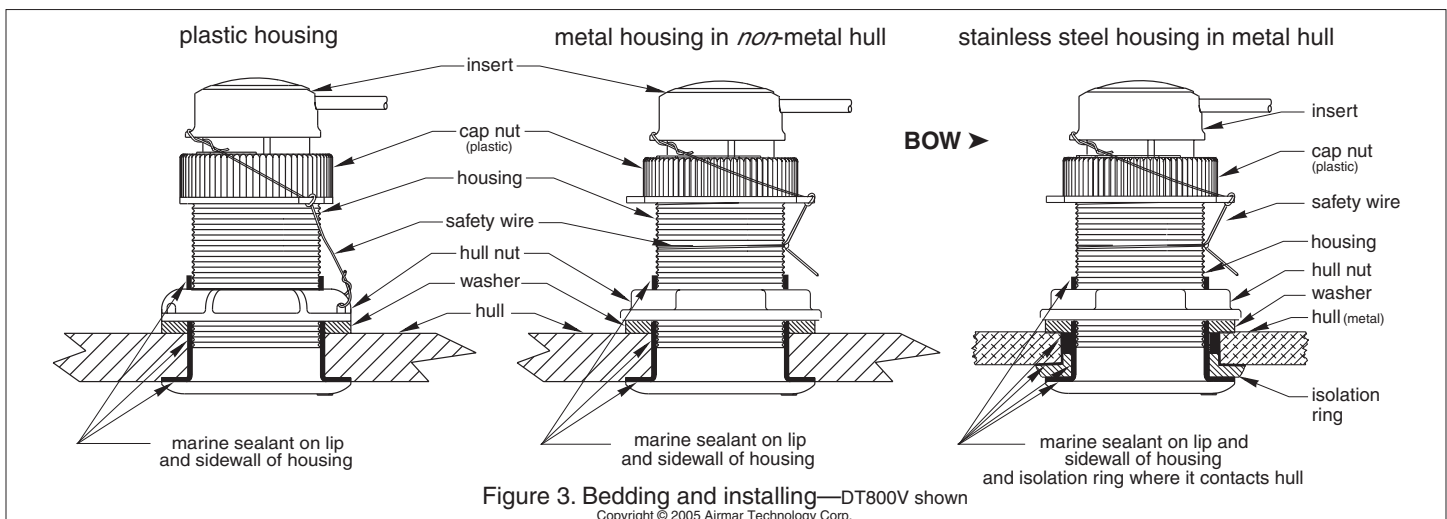

the hull nut. This will ensure there is sealant in the threads to seal the hull and to hold the hull nut securely in place.

**Stainless steel housing in a metal hull**—To isolate the stainless steel housing from the metal hull, slide the isolation ring onto the housing. Apply additional sealant to the surfaces of the ring that will contact the hull, filling any cavities in and around the ring.

## Installing

**Caution:** *Never pull, carry, or hold the transducer by the cable as this may sever internal connections.*

1. From outside the hull, push the housing into the mounting hole using a twisting motion to squeeze out excess marine sealant (see Figure 3). Align the arrow on the lip of the housing to point forward toward the bow.

2. From inside the hull, slide the washer onto the housing.

**Aluminum hull less than 6mm (1/4") thick**—Use an additional rubbery, fiberglass, or plastic washer. *Never* use bronze since electrolytic corrosion will occur. *Never* use wood since it will swell, possibly fracturing the plastic housing.

**Warning: Stainless steel housing in a metal hull only**—*Be sure the washer contacts the hull. Do not tighten the hull nut with the washer against the isolation ring, as the housing will not be firmly installed. If necessary, sand the isolation ring until the washer rests against the hull.*

3. Screw the hull nut in place *being sure* the arrow on the rim of the housing is still positioned forward toward the bow.

**Plastic housing**—*Do not* clamp tightly on the wrenching flats possibly causing the housing to fracture.

**Plastic hull nut**—*HAND-TIGHTEN* only. *Do not* over-tighten.

**Metal hull nut**—Tighten with slip-joint pliers.

**Cored Fiberglass Hull**—*Do not* over-tighten, crushing the hull.

**Wood hull**—Allow the wood to swell before tightening the nut.

4. Remove any excess marine sealant on the outside of the hull to ensure smooth water flow over the transducer.

**Warning: The O-rings must be intact and well lubricated to make a watertight seal.**

5. After the marine sealant cures, inspect the O-rings on the insert (replace if necessary) and lubricate them with the silicone lubricant supplied.

**Warning: Be sure the insert is fully inserted into the housing, and the cap nut is screwed on completely.**

6. Slide the insert into the housing with any arrow on the top pointing in the direction indicated. Screw the cap nut several turns until the threads are engaged. Continue to tighten the cap nut. *HAND-TIGHTEN* only. *Do not* over tighten. *Be careful* not to rotate the housing and disturb the sealant.

**Warning: Always attach the safety wire to prevent the insert from backing out in the unlikely event that the cap nut fails or is screwed on incorrectly.**

7. Attach the safety wire.

**Plastic housing**—Attach the safety wire to one eye in the hull nut. Keeping the wire taut throughout, lead the wire in a counterclockwise direction and thread it through one eye in the cap nut. Thread the wire through the eye a second time. Then lead the wire through the eye in the insert. Twist the wire securely to itself.

**Metal housing**—Wrap one end of the safety wire tightly around the housing and twist it together with the long end. Keeping the wire taut throughout, lead the wire straight up and through one eye in the cap nut. Thread the wire through the eye a second

time. Then lead the wire counterclockwise and through the eye in the insert. Twist the wire securely to itself.

**Caution:** *If your transducer came with a connector, do not remove it to ease cable routing. If the cable must be cut and spliced, use Airmar's splash-proof Junction Box No. 33-035 and follow the instructions provided. Cutting the cable or removing the waterproof connector, except when using Airmar's junction box, will void the transducer warranty.*

- Route the cable to the instrument *being careful* not to tear the cable jacket when passing it through the bulkhead(s) and other parts of the boat. To reduce electrical interference, separate the transducer cable from other electrical wiring and the engine. Coil any excess cable and secure it in place with zip-ties to prevent damage.
- Refer to the instrument owner's manual to connect the transducer to the instrument.

## Installation in a Cored Fiberglass Hull

The core (wood or foam) *must* be cut and sealed carefully. The core *must* be protected from water seepage, and the hull *must* be reinforced to prevent it from crushing under the hull nut allowing the housing to become loose.

**Warning: Always wear safety goggles and a dust mask.**

- Drill a 3mm or 1/8" pilot hole from inside the hull. If there is a rib, strut, or other hull irregularity near the selected mounting location, drill from the outside. (If the hole is drilled in the wrong location, drill a second hole in a better location. Apply masking tape to the outside of the hull over the incorrect hole and fill it with epoxy.)
- Using a 51 mm or 2" hole saw, cut the hole from outside the hull through the *outerskin* only (see Figure 4).
- From inside the hull, use a 60mm or 2-3/8" hole saw to cut through the *innerskin* and most of the core. The core material can be very soft. Apply only light pressure to the hole saw after cutting through the inner skin to avoid accidentally cutting the *outerskin*.
- Remove the plug of core material so the *inside* of the outer skin and the inner core of the hull are fully exposed. Sand and clean the inner skin, core, and the outer skin around the hole.

**Caution: Completely seal the hull to prevent water seepage into the core.**

- If you are skilled with fiberglass, saturate a layer of fiberglass cloth with a suitable resin and lay it inside the hole to seal and strengthen the core. Add layers until the hole is the correct diameter.

Alternatively, a hollow or solid cylinder of the correct diameter can be coated with wax and taped in place. Fill the gap between the cylinder and hull with casting epoxy. After the epoxy has set, remove the cylinder.

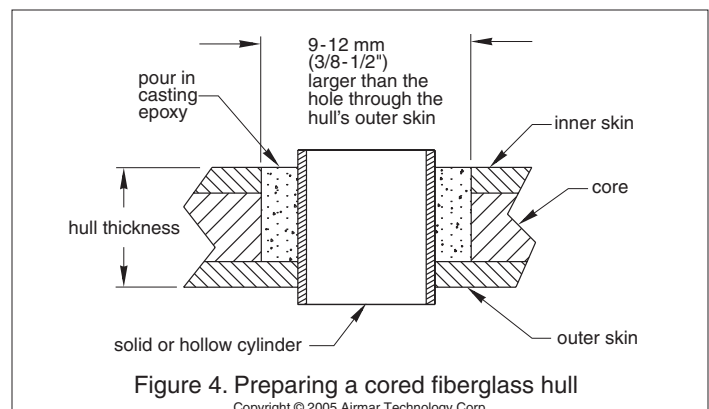

- Sand and clean the area around the hole, inside and outside, to ensure that the sealant will adhere properly to the hull. If there is any petroleum residue inside the hull, remove it with either mild household detergent or a weak solvent (alcohol) before sanding.
- Proceed with “Bedding” and “Installing” (see pages 2 and 3).

## Checking for Leaks

**Warning:** *DO NOT leave the boat in the water unchecked for several days.*

When the boat is placed in the water, **immediately** check the thru-hull transducer for leaks. Note that very small leaks may not be readily observed. *Do not* leave the boat in the water for more than 3 hours before checking it again. If there is a small leak, there may be considerable bilge water accumulation after 24 hours. If a leak is observed, repeat “Bedding” and “Installing” **immediately** (see pages 2 and 3).

## Operation & Maintenance

### DT800V only—How the Valve Works

**WARNING: THE VALVE IS NOT A WATERTIGHT SEAL!**  
Always use the insert or the blanking plug secured with the safety wire for a watertight seal.

The DT800V incorporates a self-closing valve which minimizes the flow of water into the boat when the insert is removed. The curved flap valve is activated by both a spring and water pressure. Water pushes the flap valve upward to block the opening, so there is no gush of water into the boat.

### Using the Blanking Plug

To protect the insert, use the blanking plug:

- When the boat will be kept in salt water for more than a week.
- When the boat will be removed from the water.
- When aquatic growth buildup is suspected due to inaccurate readings from the instrument.

**Warning:** *The O-rings must be intact and well lubricated to make a watertight seal.*

- On the blanking plug, inspect the O-rings (replace if necessary) and lubricate them with the silicone lubricant supplied or petroleum jelly (Vaseline®) (see Figure 5).
- Remove the insert from the housing by removing the safety wire and unscrewing the cap nut (see Figure 3). This will jack out the insert.

**DT800**—With the blanking plug ready in one hand, pull the insert most of the way out. Remove the insert and rapidly replace it with the blanking plug. With practice, only 250ml (10oz.) of water will enter the boat.

**DT800V**—Grasp the insert and remove it with a slow pulling motion. Slide the blanking plug into the housing.

**Note:** *In the very unlikely event that the valve breaks, replace the housing the next time the boat is hauled.*

**Warning:** *Be sure the blanking plug is fully inserted into the housing, and the cap nut is screwed on completely.*

- Screw the cap nut several turns until the threads are engaged. Continue to tighten the cap nut. **HAND-TIGHTEN** only. *Do not* over-tighten.

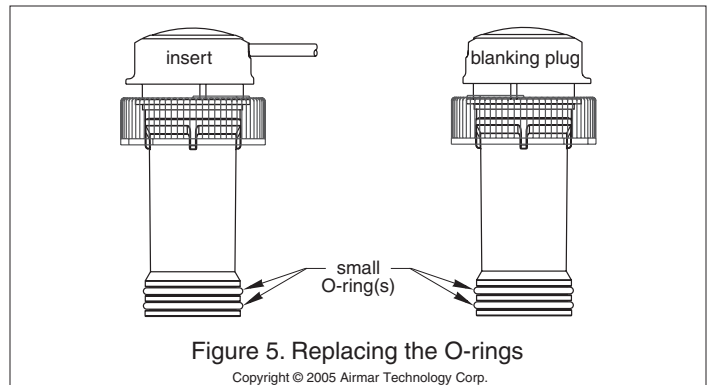

Figure 5. Replacing the O-rings

Copyright © 2005 Airmar Technology Corp.

**WARNING:** *Always attach the safety wire to prevent the blanking plug from backing out in the unlikely event that the insert nut and/or cap nut fails or is screwed on incorrectly.*

- Reattach the safety wire.

### Servicing the Insert

Aquatic growth can accumulate rapidly on the transducer’s surface reducing performance within weeks. Clean the insert with a Scotch-Brite® scour pad and mild household detergent, *being careful* to avoid scratching the depth transducer. If fouling is severe, lightly wet sand it with fine grade wet/dry paper.

O-rings must be free of abrasions and cuts to ensure a watertight seal. Install two O-rings near the bottom of the insert (see Figure 5). Place the remaining two O-rings in similar positions on the blanking plug.

### Winterizing

After the boat has been hauled for winter storage, remove the blanking plug to let the water drain away before reinserting it. This will prevent any water from freezing around the blanking plug and possibly cracking it.

### Replacement Parts

Lost, broken, or worn parts should be replaced immediately. Obtain parts from your instrument manufacturer or marine dealer.

If you have purchased a plastic housing and have a wood hull or desire greater strength, purchase an Airmar metal housing.

Hull Nut or Isolation Ring	Housing, Nut & Washer <i>NO VALVE</i>
04-004 (plastic)	33-100 (bronze, low profile, B17)
02-030 (bronze)	33-224-01 (bronze, counterbore, B21)
02-570-01 (stainless steel)	33-091-01 (bronze, flush, B119)
04-186-1 (isolation ring)	33-495-01 (stainless steel, low profile, SS577)
O-rings	33-519-01
Blanking Plug	33-538-01
Housing with Valve, Nut & Washer	33-510-01 (plastic, low profile, P617)

**Transducer Replacement**—The information needed to order a replacement Airmar multisensor is printed on the cable tag. *Do not* remove this tag. When ordering, specify the part number, date, and frequency in kHz. For convenient reference, record this information on the top of page one.