

FURUNO

D800 DT800

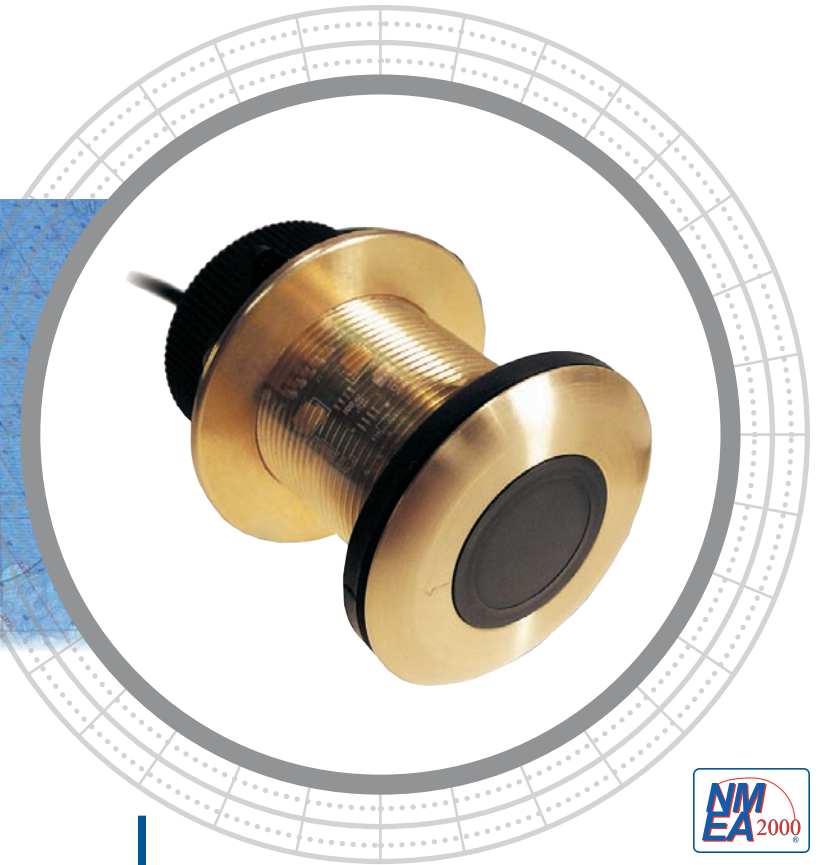
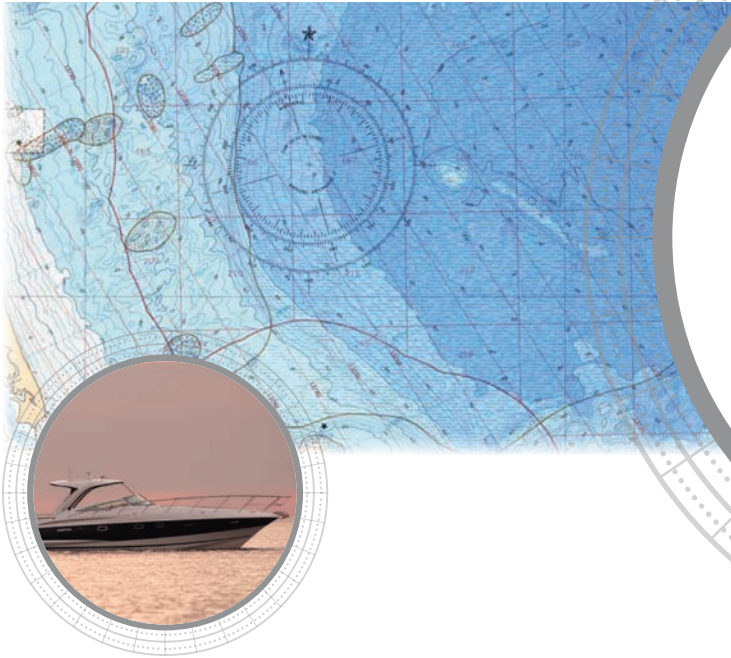

The Smart Alternative!

Airmar's D800 and DT800 Smart™ Sensors feature embedded micro-electronics. Depth and temperature signals are processed inside the sensor and can be displayed on any radar, chart plotter, or device that accepts NMEA 0183 or NMEA 2000® data. The 235 kHz frequency prevents mutual interference with other echosounders on the vessel.

Angle for Results

The DT800 Tilted Element Transducer's low-profile housing compensates for hull deadrise. The unique design tilts the ceramic element inside the transducer housing—giving all the advantages of a fairing block without a hull protrusion. Designed with Airmar's exclusive Broadband Ceramic Technology, the 235 kHz element improves resolution without sacrificing sensitivity. The higher power rating 100 W RMS provides spot-on depth readings in as little as 0.5 m (1.6') of water and can reach depths up to 180 m (600').

Tilted Element™ Thru-Hull Smart™ Sensors

Features

- Tilted-Element Broadband-Ceramic versions available in a 0° or 12° or 20° tilt
- Available in NMEA 0183 and NMEA 2000® versions
- 235 kHz frequency prevents mutual interference with other echosounders on the vessel
- Temperature sensor in DT800 models
- Cable lengths up to 100 m (330') are possible with no loss of performance—NMEA 0183 only
- Plastic, bronze, or stainless steel housings available
- Retractable housing with water valve
- Available in low-profile, countersunk, or beveled-edge housings

D800, DT800

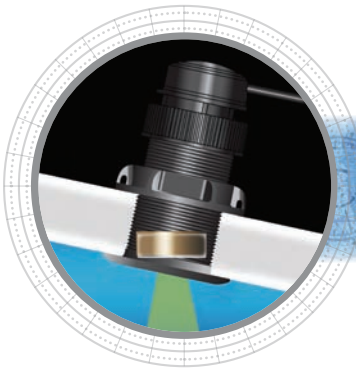

Technical Information

235 kHz Non-Broadband / Broadband

Number of Elements and Configuration	○	
Beamwidth (@-3 dB)	12°	
RMS Power (W)	60 W	100 W

SPECIFICATIONS

Weight:

- 0.9 kg (2 lb)—Plastic
- 1.5 kg (3.4 lb)—Bronze
- 1.6 kg (3.6 lb)—Stainless Steel

Acoustic Window: Urethane

Data Update Rate: 1 per second

Minimum Depth Range: 0.5 m (1.6')

Maximum Depth Range:

- Up to 100 m (330')—Non-Broadband
- Up to 180 m (590')—Broadband

Pressure Rating: 3 m (10')

Supply Voltage:

- 10 VDC to 25 VDC—NMEA 0183
- 9 VDC to 16 VDC—NMEA 2000

Supply Current:

- <40 mA—NMEA 0183
- <200 mA—NMEA 2000

Standard Cable Length:

- 10 m (33')—NMEA 0183
- 6 m (20') devicenet—NMEA 2000

Temperature Accuracy: ±0.5°C (±1.8°F)

Temperature Sensor Range: -10°C to 40°C (14°F to 104°F)

NMEA 2000® Load Equivalency Number (LEN): 4

CE Regulation: Complies to IERC60945

DATA OUTPUT PROTOCOL

NMEA 0183 Sentence Structure

- \$SDBT, DDPT... Depth
- \$YXMTW..... Water Temperature

NMEA 2000® Supported PGNs

- 59392..... ISO Acknowledgement
- 600928..... ISO Address Claim
- 126208..... Acknowledge Group Function
- 126464..... Transmit PGN List Group Function
- 126464..... Received PGN List Group Function
- 126996..... Product Information
- 128267..... Water Depth (With Transducer Offset)
- 130310..... Environmental Parameters (Water Temperature)
- 130311..... Environmental Parameters (Water Temperature)
- 130312..... Environmental Parameters (Water Temperature)

DIMENSIONS

P617V Plastic, B617V Bronze, and SS617V Stainless Steel

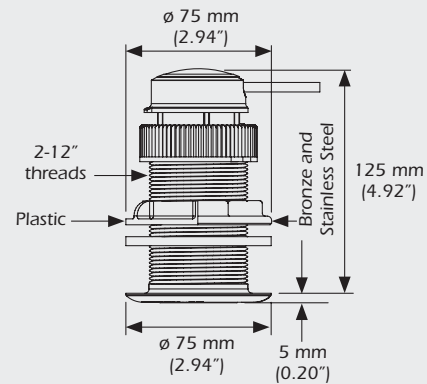

- Also compatible with B17 and SS577 housings