

# FURUNO

**AIS**  
Automatic Identification System



Model:  
FA-170

# The **FURUNO FA-170 AIS** presents data for collision avoidance with its easy-to-use interface

**AIS**  
Automatic Identification System



- ▶ Class A AIS transponder
- ▶ Clear 4.3" color display
- ▶ Displays information about the AIS-equipped ships, as well as, coastal stations and Aids to Navigations within VHF coverage
- ▶ Outputs AIS data to ECDIS, radar and other navigational equipment for collision avoidance support
- ▶ Sufficient output ports for dual configuration of ECDIS and radar system
- ▶ LAN interface available for efficient network integration into a bridge system
- ▶ BAM (Bridge Alert Management) ready  
Meets the specific requirements for alerts and interconnection with Bridge Alert Management as specified in IMO MSC.302 (87).
- ▶ Optional pilot plug available
- ▶ Receives AIS-SART signals for assisting in streamlining SAR activities

## Plotter display

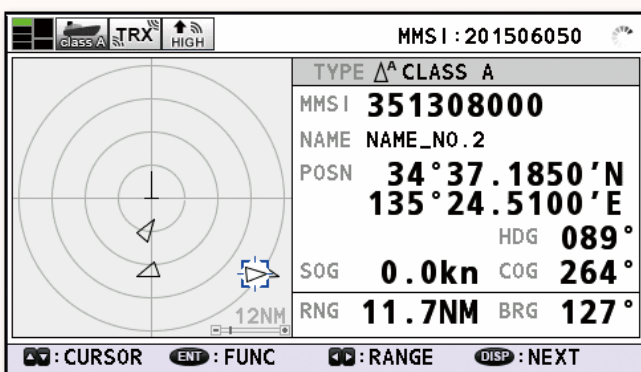

Displays symbols for AIS-equipped ships, base stations, AIS-SARTs, and so on. When you select a certain target, the information about the ship (MMSI (or name, when available), heading, SOG, COG, etc.) is displayed.

### AIS symbols

	Own ship symbol		AIS base station		AIS-SART/AIS MOB/EPIRB-AIS
	Target		Aid to Navigation (physical)		SAR aircraft
	Selected target		Aid to Navigation (virtual)		SAR vessel

## Target list

The FA-170 can store up to 2048 AIS targets and AIS-SARTs.

NAME/MMSI/TYPE	RNG [NM]	BRG [°]	AGE [']
300000001	1.0	000.0	1
DUMMY_NAME_NO.2	1.1	010.0	2
DUMMY_NAME_NO.3	1.2	020.0	3
BS:300000004	1.3	030.0	4
{SAR/AIRCRAFT}	1.4	040.0	5
{SAR/YESSEL}	1.5	050.0	6
300000007	1.6	060.0	7
DUMMY_NAME_NO.8	1.7	070.0	8

### Quick-access functions

When you select one target from the list and press [ENT] key, the pop-up window is generated.

FUNCTION
NEW MSG
VIEW DETAIL
SORT (NORMAL)
NAME REQUEST (DANGER)

NEW MSG (TEXT)
MSG TYPE
ADDRESSED TO
CH
TEXT

TARGET DETAIL
NAME
TYPE
CLASS
POSN
ROT
SOG
COG

The FA-170 displays the detailed information on the selected target. Also, you can create an AIS message or send a name request to the target ship.

## Dangerous target list

The dangerous target list displays the name and particulars of targets classified as dangerous targets.

## Own ship information

Displays own ship's position, heading, ROT, COG, SOG, destination, ship size, MMSI, name, and so on.

OWN INFORMATION
UTC
POSN
ROT
SOG
NAV STATUS
DESTINATION
NO. OF PERSONS

DESTINATION LIST
01: KOBLE
02: YOKOHAMA
03: BUSAN
04: SEATTLE
05: SAN FRANCISCO
06: BRISBANE
07: = NO ENTRY =
08: = NO ENTRY =

When you enter the voyage-related data, you can select a destination from the list. Up to 20 destination names can be preset on the list. Cut, copy and paste functions are available while editing the list.

## Alert list

Displays all (current and past) alerts

TIME (UTC)	ALERT	LOG
30/JAN 17:20	TX MALFUNCTION	01/06
29/JAN 17:20	ANTENNA VSWR EXCEEDS LIMIT	
28/JAN 17:20	RX CHANNEL 1 MALFUNCTION	
27/JAN 17:20	RX CHANNEL 2 MALFUNCTION	
26/JAN 17:20	GENERAL FAILURE	
25/JAN 17:20	ACTIVE AIS-SART	

TIME (UTC)	ALERT	LOG
01/01/04 10:49	TX MALFUNCTION	
02/01/04 10:48	TX MALFUNCTION	
03/01/04 10:47	TX MALFUNCTION	
04/01/04 10:46	TX MALFUNCTION	
05/01/04 10:45	TX MALFUNCTION	
06/01/04 10:44	ANTENNA VSWR EXCEEDS LIMIT	

## Short safety-related messages

TIME (UTC)	FROM
08/APR 09:45	200000000
08/APR 09:44	200000001
08/APR 09:43	200000002
08/APR 09:42	200000003
08/APR 09:41	200000004
08/APR 09:40	200000005
08/APR 09:39	200000006

Short safety-related messages can be exchanged with a specified MMSI or all AIS-equipped ships via VHF channels. The FA-170 can store up to 20 transmitted, as well as up to 20 received messages.

When you select one message and press [ENT] key, the pop-up window is generated where the message contents can be viewed and reply messages can be created for transmission.

# SPECIFICATIONS

## GENERAL

Product Name	U-AIS TRANSPONDER
Reporting capacity	2250 reports per minute on 1 channel 4500 reports per minute on 2 channels
Standards	IMO MSC.74(69) ANNEX 3, IMO MSC.302(87), IMO A.694(17), IMO MSC.191(79), ITU-R M.1371-5, DSC ITU-R M.825-3, IEC61993-2 Ed. 2, IEC60945 Ed. 4 CORRIGENDUM 1, IEC 62288 Ed. 2, IEC 61162-1 Ed. 4, IEC 61162-2 Ed. 1, IEC61162-450 Ed. 1

## TRANSPONDER UNIT

TX/RX frequency	156.025 to 162.025 MHz
Bandwidth	25 kHz
Output power	1 W or 12.5 W selectable
DSC receiver	156.525 MHz, CH70 fixed

## INTERFACE

COM port	6 ports input/output, IEC61162-1 Ed. 4 / IEC61162-2 Ed. 1
SENSOR port	3 ports input only, IEC61162-1 Ed. 4
LAN	1 port, IEC61162-450 Ed. 1, 100 Base-TX, Auto MDI/MDIX
Alarm output	1 port, Relay contact (select from Normally closed (default) or Normally open), Alarm ACK

## GPS RECEIVER

Receiving channels	12 channels parallel, 12 satellites tracking
RX frequency	1575.42 MHz
RX code	C/A code
Position accuracy	GPS: less than 13 m (2 drms, HDOP<4) DGPS: less than 5 m (2 drms, HDOP<4)

## VHF ANTENNA

50 Ω Single dipole antenna
----------------------------

## MONITOR UNIT

Screen size	4.3-inch color LCD, 480 x 272 dots (WQVGA)
Viewing area	95.04 (W) x 53.856 (H) mm
Brightness adjustment	18 steps

## POWER SUPPLY

Transponder unit	12-24 VDC 6-3 A
Monitor unit	12 VDC 0.3 A max. (supplied by Transponder unit)
AC/DC Power Supply Unit PR-240 (option)	100/110/200/220 VAC, 1ø, 50/60 Hz

## ENVIRONMENT

Ambient Temperature	Transponder unit/Monitor unit/ Pilot plug unit/Power supply unit	-15 to +55°C
Relative humidity	GPS/VHF combined antenna/GPS antenna	-30 to +70°C
Degree of protection	Transponder unit	IP22 at bulkhead mount, IP20 at floor
	Monitor unit	IP22, IP35 with optional Waterproofing kit
	Pilot plug unit	front panel: IP22
	Power supply unit	IP22
	GPS/VHF combined antenna/GPS antenna	IP56
Vibration	IEC60945 Ed.4	

## EQUIPMENT LIST

### Standard

1	Transponder unit	FA-1701	1 unit	
2	Monitor unit	FA-1702	1 unit	
3	GPS/VHF combined antenna and Distributor unit	GVA-100-T and DB-1	1 set	] Selectable
4	GPS antenna	GPA-017S	1 unit	

### Option

1	Antenna cable kit for GPS/VHF combined antenna or GPS antenna (30/40/50 m)	
2	Antenna base (for pipe mount/offset bracket/deck mount/handrail mount)	
3	VHF antenna	FAB-151D
4	Power supply unit	PR-240
5	Pilot plug unit	FA-1703
6	AD converter	AD-100
7	Sub monitor unit	FA-1702
8	Flush mount kit for Monitor unit	OP24-35
9	Monitor flush mount kit for retrofitting from FA-150	OP05-140
10	Waterproofing kit for Monitor unit (IP35)	OP05-139

# INTERCONNECTION DIAGRAM

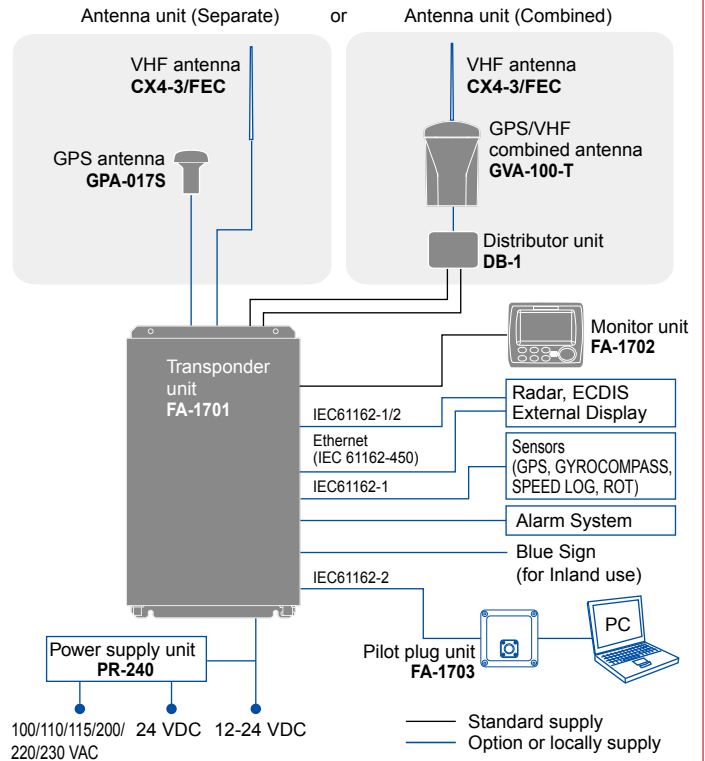

## Monitor unit (flush mount)

FA-1702 0.6 kg, 1.3 lb

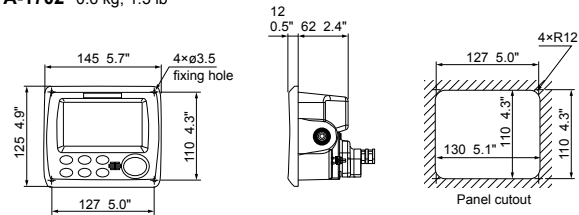

## Monitor unit (hanger)

FA-1702 0.7 kg, 1.5 lb

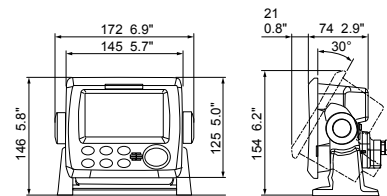

## Transponder unit

FA-1701 3.0 kg, 6.6 lb

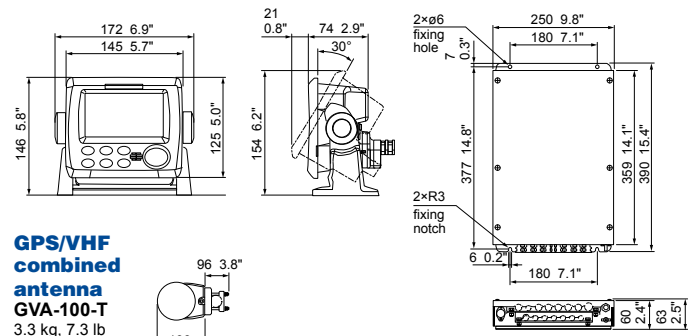

## GPS/VHF combined antenna

GVA-100-T

3.3 kg, 7.3 lb

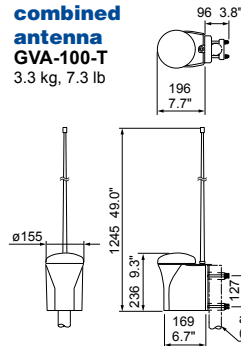

## GPS antenna

GPA-017S

0.12 kg, 0.3 lb

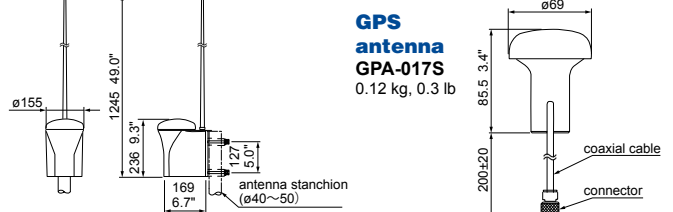

All brand and product names are registered trademarks, trademarks or service marks of their respective holders.  
SPECIFICATIONS SUBJECT TO CHANGE WITHOUT NOTICE