



Furuno NMEA 2000 Installation Guide

1.	NMEA 2000 General Overview	
2.	Basic Network Components	
2.1.	Starter Kit	2
2.2.	Connectors and Terminators	2
2.3.	Cables	2
3.	Network Designing	
3.1.	Network Power Source and Connection Type	3
3.2.	Estimated Voltage Drop and Effective Backbone Length	5
3.3.	Drop Cable Length.....	6
3.4.	Gender Distinction of Connector	6
3.5.	Termination Resistor.....	7
3.6.	Shielding	7
4.	Field Programming (Instance Setup)	
4.1.	What is Instance?	8
4.2.	Device Instance Setup via NAVnet TZtouch2/ Touch3.....	9
4.3.	Data Instance Setup via NAVnet TZtouch2/ Touch3	10
5.	General Information and Required PGNs	

1. NMEA 2000 GENERAL OVERVIEW

Key Points;

- Network Power: 9-16V, isolated from other circuits.
- Maximum Backbone Length: 100m with micro/mini(light) / 200m with mid(heavy) cable
- Maximum Number of Devices per Backbone, 50 ea.
- Maximum Drop Length per Drop, 6m.
- Maximum Total Drop length per Backbone, 78m.
- Maximum Power Capacity per Segment, 3A with light / 8A with heavy cable.

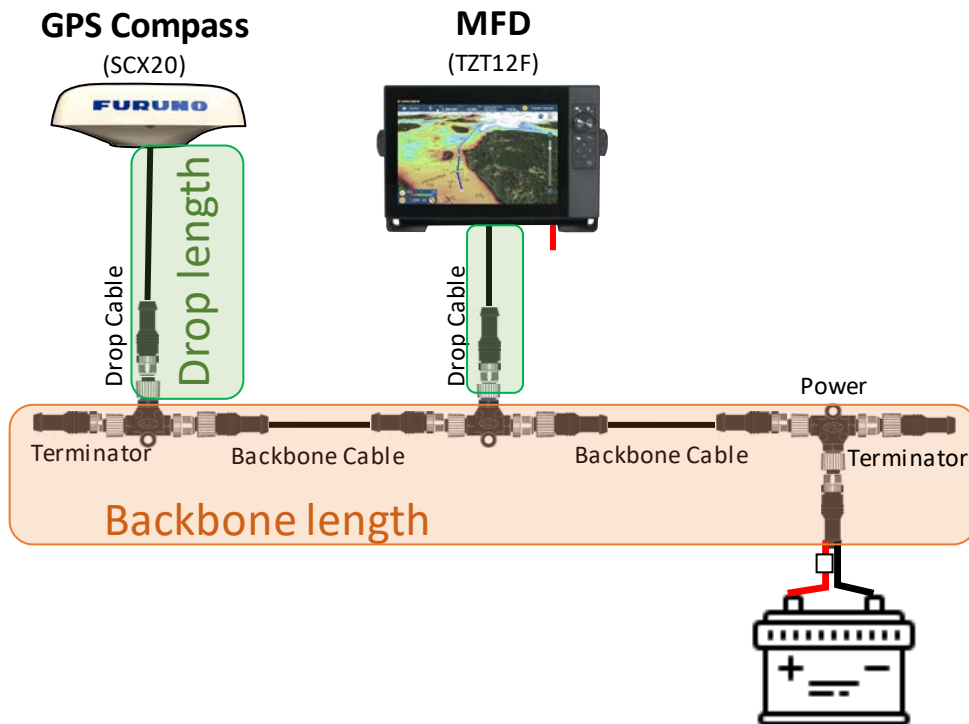

2. BASIC NETWORK COMPONENTS

NMEA2000 networks need to consist of NMEA 2000 certified devices, approved tee-connectors, and cables. FURUNO USA supplies NMEA approved components as follows.



2.1. Starter Kit

NMEA2000 Starter Kit			
Consists of	NMEA2000 Drop Cable, 2m	1 ea.	
	NMEA2000 Backbone Cable, 6m	1 ea.	
	NMEA2000 Power Tee, Micro F/F, 8m	1 ea.	
	NMEA2000 Tee-Connector, Micro F/F/M	2 ea.	
	NMEA2000 Micro Terminator, Micro Male	2 ea.	
Part Number	AIR-033-745		

2.2. Connectors and Terminators

Name	NMEA2000 Tee Connector	NMEA2000 Micro Terminator	NMEA2000 Micro Terminator
			
Conn. Type	Micro Female/Female/Male	Micro Male	Micro Female
P/N	AIR-052-531	AIR-335-791	AIR-335-792

2.3. Cables

Name	NMEA2000 Micro Cable	NMEA2000 Micro Cable (Angled)	NMEA2000 Power Tee	
				
Conn. Type	Micro Male/Female	Micro Male/ Female, Angled	Micro Female/ Female	
P/N	1 meter	001-533-060-00	8 meters	AIR-335-792
	2 meters	001-533-070-00		
	6 meters	001-533-080-00		
		1 meter	001-105-830-10	
		5 meters	001-105-840-10	
		10 meters	001-105-850	

3. NETWORK DESIGNING

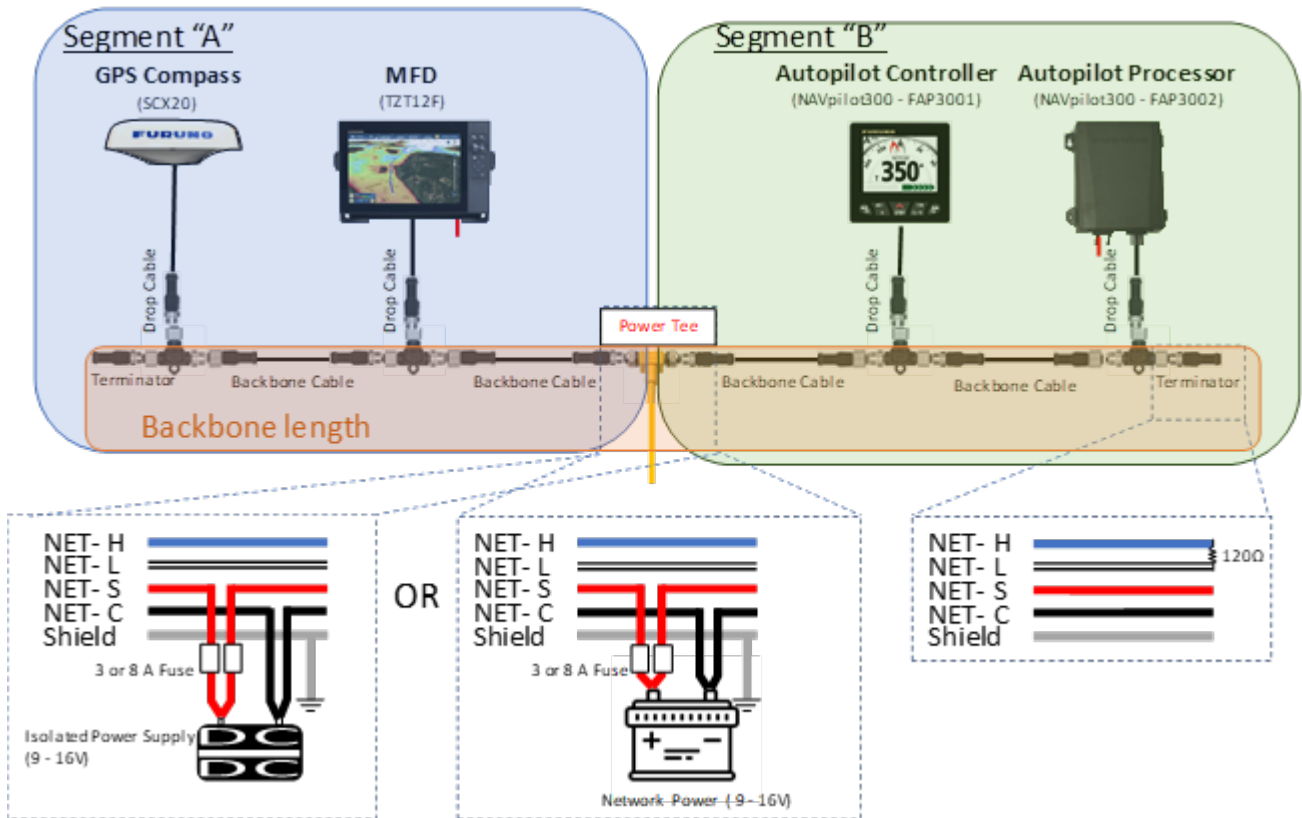

3.1. Network Power Source and Connection Type

The NMEA 2000 network is designed to be electrically isolated from other circuits to prevent radio interference, so a dedicated network power source is required. The range should be 9 -16V. The network power source should be either **single-point connection of a battery** or **one or more isolated power supplies** distributed along the network, but it should **not be a combination of battery and power supply connections**, and each power line should have its own fuse. There are several power-connection types, and you can choose the one best suited for your system.

- **Single Leg Backbone Power Connection**
Simplest and most common method, and most boats can be utilize this method.

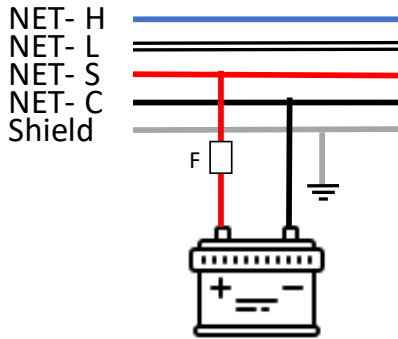

A battery

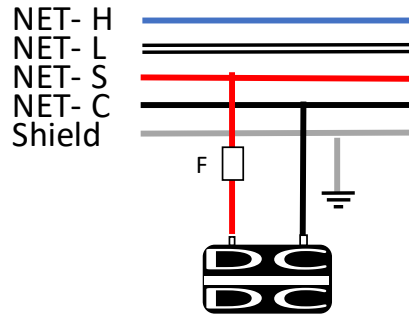

An isolated Power Supply

- **Double Leg Backbone Power Connection**
The double leg method will help to increase total power capacity per network by separating segments, but a NMEA 2000 dedicated power Tee or power isolator is required. Both power legs should connect to an isolated power supply or a battery.

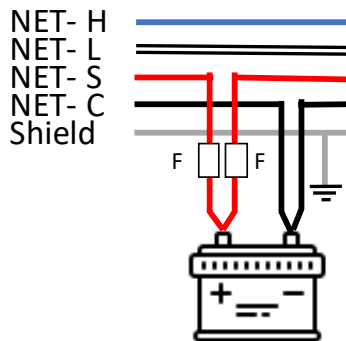

A battery

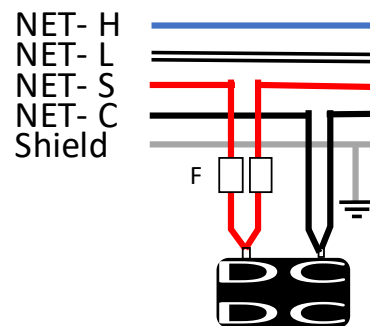

An isolated Power Supply

- **Multiple Leg Backbone Power Connection**
Multiple Legs may be required for vessels requiring a larger network. This method can be used with isolated power supplies only. Each power leg should be isolated from others, and **a single-point common reference is necessary** to avoid ground loops and to maintain control of ground-voltage levels between nodes.

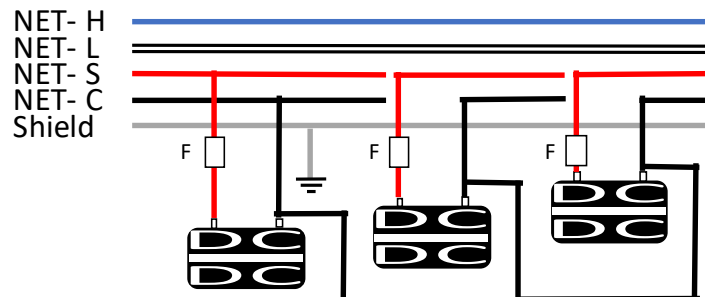

Single-point Common Reference
Isolated Power Supplies

3.2. Estimated Voltage Drop and Effective Backbone Length

Maximum Backbone length is defined by the standard but, Voltage Drop is always an important factor for actual network planning in electrical world, without exception. The voltage drop can be calculated from the following formula, and it will determine the effective Backbone length for your system. The network diagram describing Load Equivalent Number (LEN) per device and cable lengths will be required to calculate the voltage drop.

$$VD = 0.1 \times NL \times BL \times \text{Cable Resistance}$$

- VD = Voltage Drop (V)
- NL = total Network Len
- BL = Backbone Length (m)
- Cable Resistance = 0.0057Ω/m for light cable

The voltage drop should be less than 1.5V for 12V power networks. This is the nominal value of a 12V battery. Or less than 3.0V for 13.8V power which is typical power voltage from an isolated power supply.

A simplified graph indicating effective Backbone length vs Total LEN is shown below. (Orange area is overlapped on the Blue area.) If the cable length of your system is positioned in the masked area in the graph (based on your power source), the length should be fine.

This method should not be applied to multiple power supply network, and you might need to use the detailed diagnosis method defined by NMEA 2000 standard.

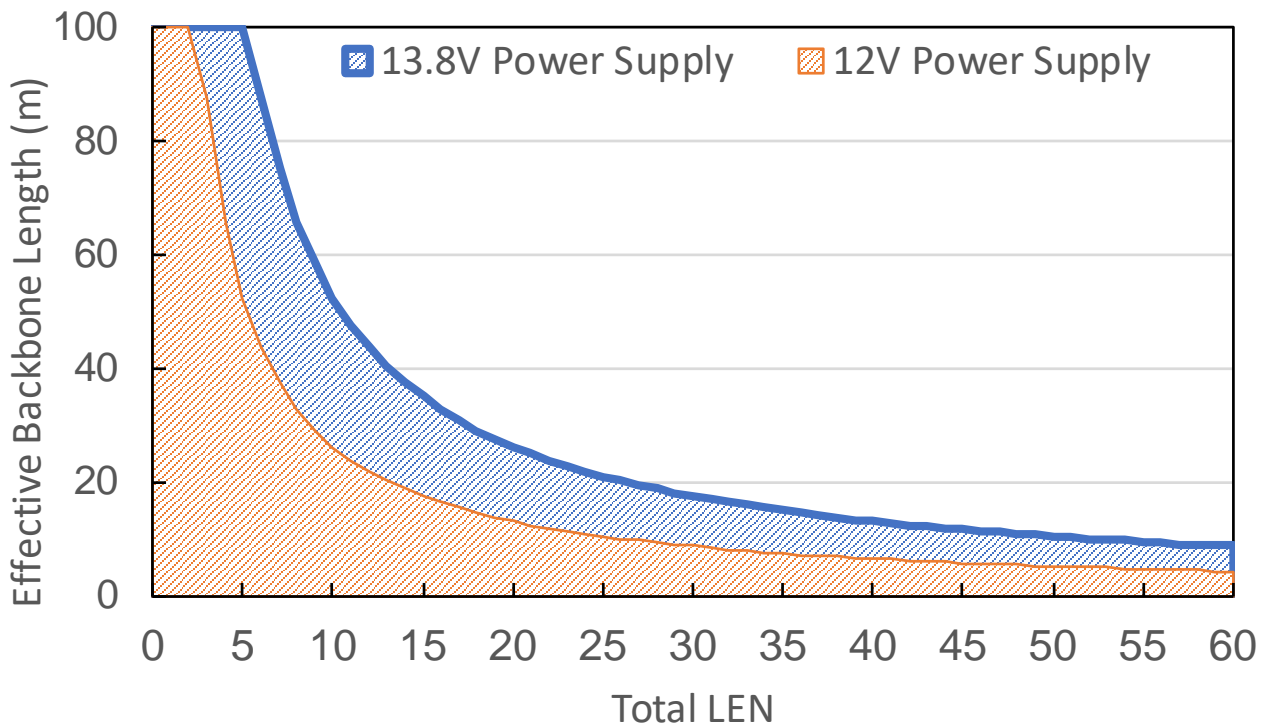

3.3. Drop Cable Length

The Drop Cable is a cable between the backbone and a device, and each cable length should not exceed 6 meters for stable communication. Additionally, the Total Drop Length per backbone should be under 78 meters.

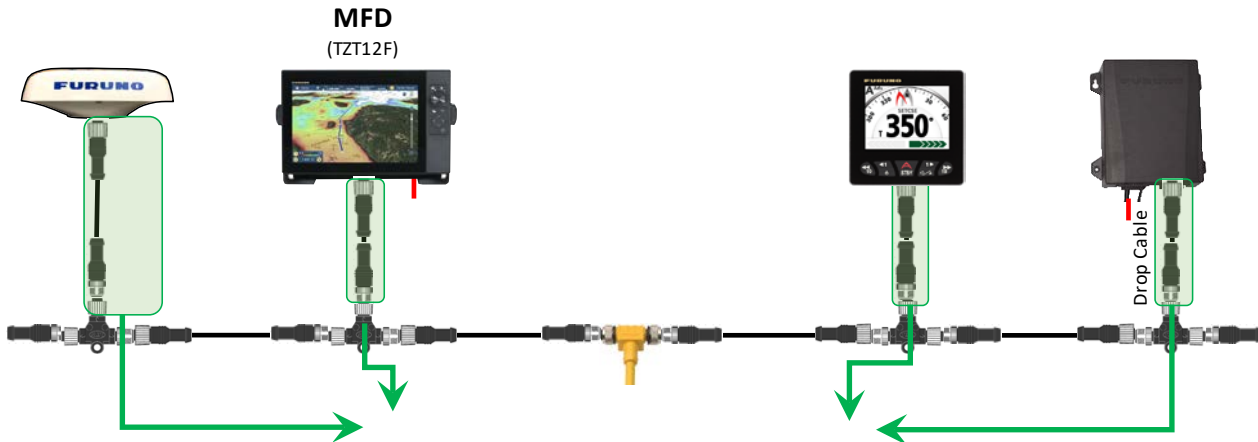

3.4. Gender Distinction of connector

Commonly female connectors are placed at the power supply side and male connectors are used at the power consuming side to prevent inadvertent touching of live conductors in the electronics world. You can always find a male connector on FURUNO NMEA 2000 device. NMEA 2000 Tee connector is designed to have devices connect to the center Female connector, and female and male connector at the sides should be used as backbone.

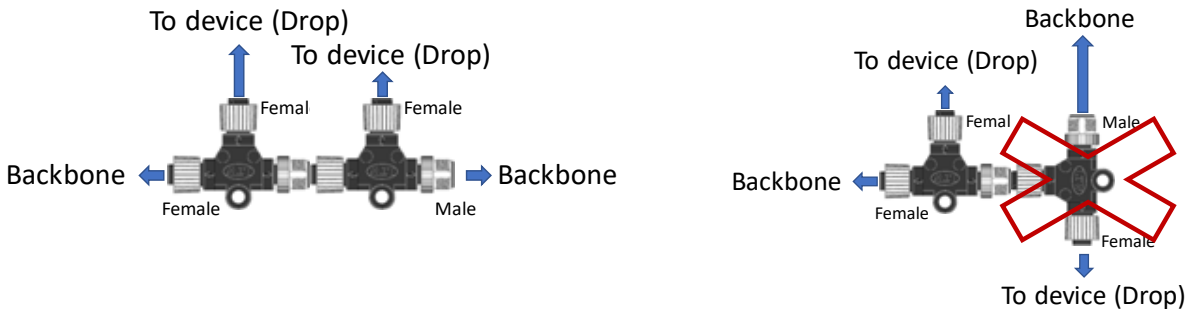

3.5. Termination Resistor

NMEA 2000 networks should have **Two 120 Ω terminators**, one **at each end of Backbone** to prevent signal reflections. One male and female terminator needs to be prepared with single power insertion network, and two male terminators will be required for the network using NMEA 2000 dedicated power tap cable. Total resistance of the finished network should read ~60 Ω.

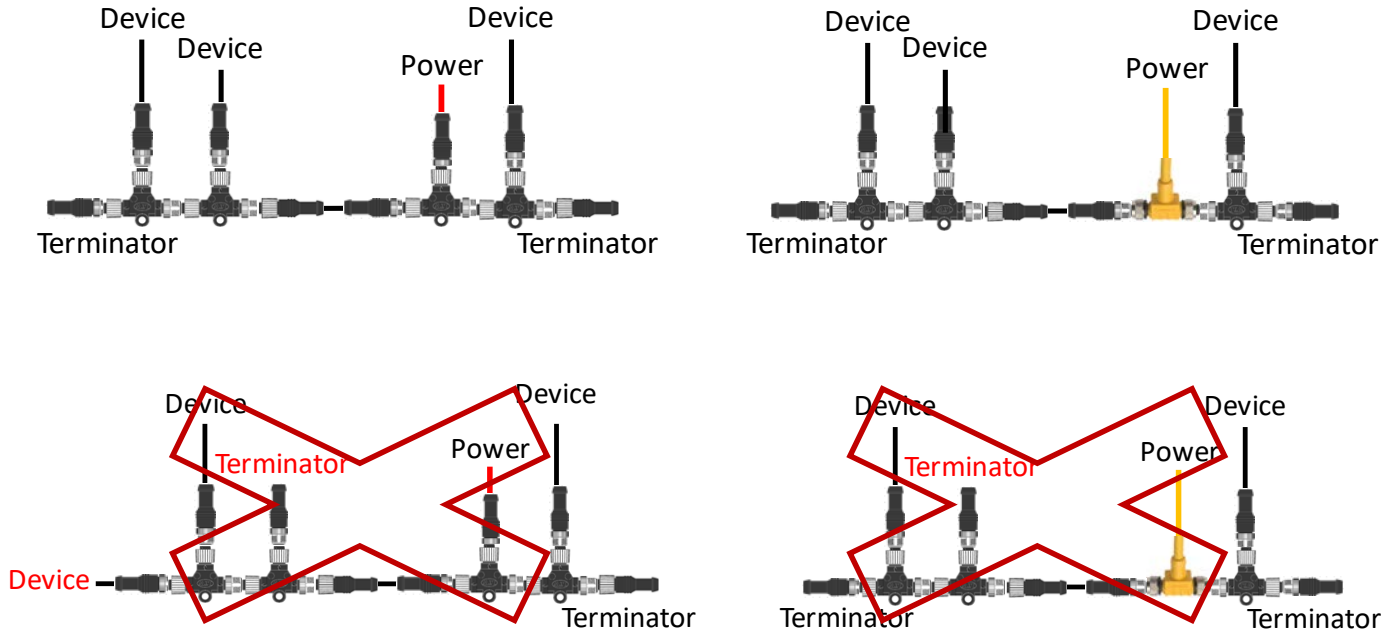

3.6. Shielding

The NMEA 2000 network is designed to be isolated from other circuits, so the shield cable is not bonded to device chassis. NMEA 2000 shielding should be continuous throughout the network and be connected to **RF ground at One Single Point**.

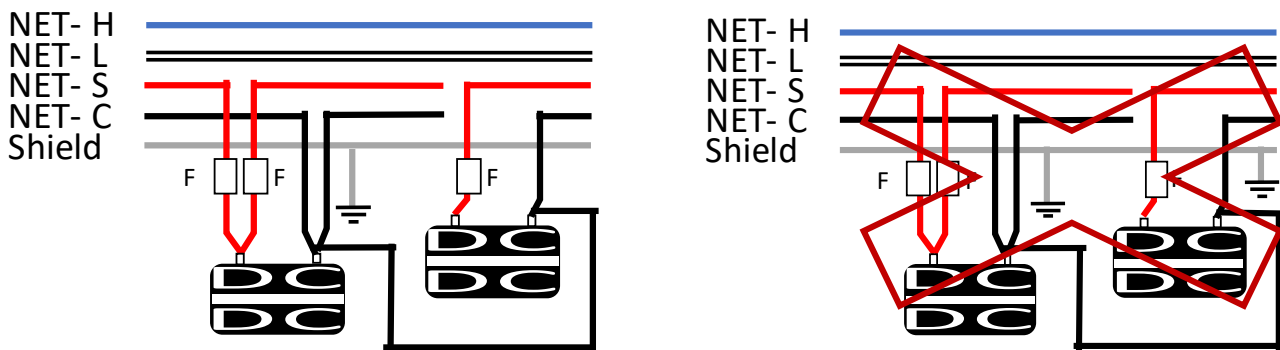

4. FIELD PROGRAMMING (INSTANCE SETUP)

4.1. What is Instance?

NMEA 2000 devices are designed to have customizable fields for onsite grouping/identification of the data from duplicated and/or similar devices on the same network. So the first thing you do after installing NMEA 2000 devices is instancing as follows:

- **Device Instance**

Device instance needs to be assigned manually to NMEA 2000 devices to identify the data from duplicated and/or similar devices on the same network. Proper instancing to devices is the most important step for a stable network. Each device which can output the same PGN (data) in the network must be assigned a unique instance. (0 to 255).

- **Data instance**

Data instance is designed to identify multiple PGNs carrying the same data from different sources transmitted by one device, like an engine gateway or a tank sensor connected to multiple level sensors. The valid range varies per PGN, and the configuration method depends on the gateway or sensor being used.

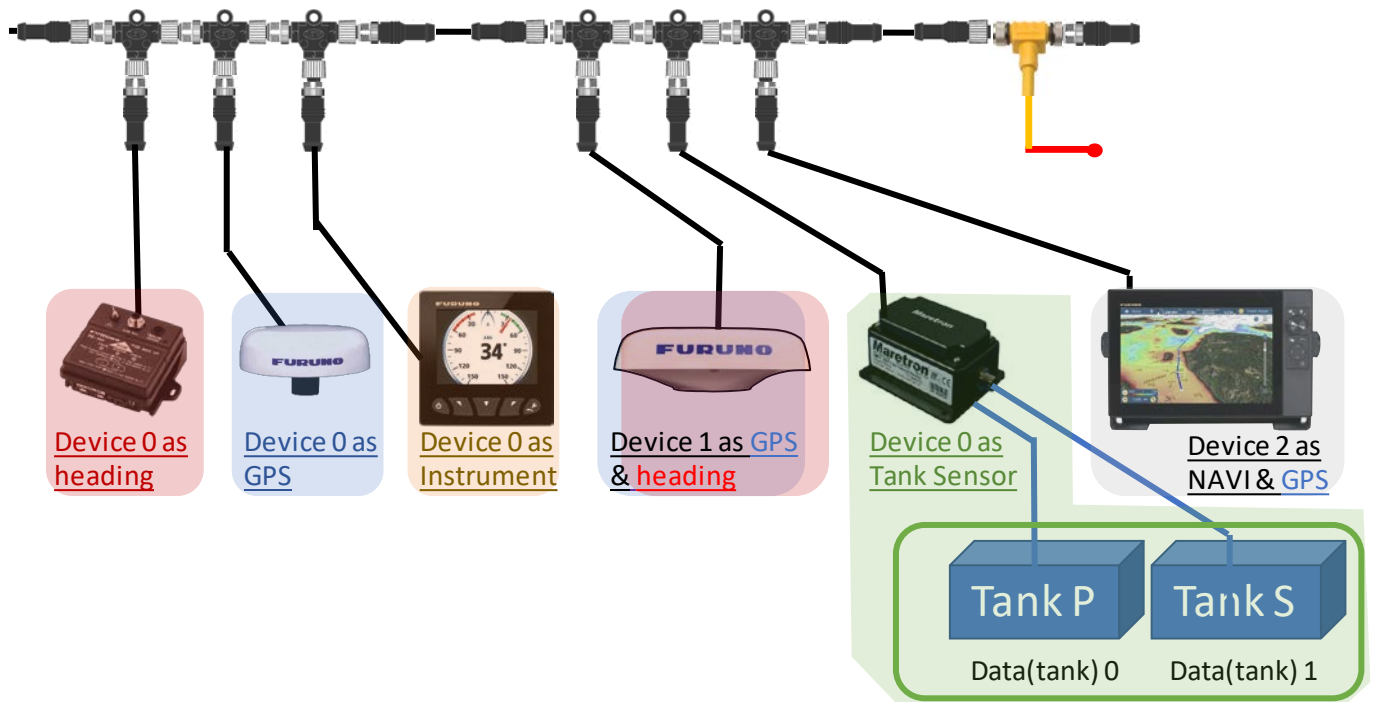

4.2. Device Instance Setup via NavNet TZTouch2/Touch3

- 1) Home-> Settings-> Initial Setup-> Sensor List
- 2) Open "Sensor List", found under Initial Setup
- 3) Select the product
- 4) Tap on Device Instance of sensor, then a keypad appears.
- 5) Enter the device instance to ensure there is no conflict with other devices which output the same PGNs.
- 6) Some devices require a power cycle to apply the change.

The image consists of three screenshots from the NavNet TZTouch2/Touch3 interface, illustrating the steps to set a device instance for a PG-700 sensor.

Top Screenshot: Sensor List
This screenshot shows the "Sensor List" screen. It is divided into two sections: "NETWORK SENSOR" and "CAN BUS SENSOR". The "CAN BUS SENSOR" section contains a table with the following data:

Name	Nickname	Version	Device Instance	Sys. Instance
TZT19F (Me)	TZT19F	01.07.01.07.01.01:	0	0
SC-33	SC-33	2051593-01.01.205159...	3	0
WX Series Weathe...	WX Series Weathe...	2.006,2.202,2.003,2.202	1	0
GP-330B	GP-330B	1.300,1.318,13.5.31,	4	0
PG-700	PG-700	01.01.02.01	0	0

The "PG-700" row is highlighted with a red box. A red arrow points from this row to the middle screenshot.

Middle Screenshot: PG-700 Overview
This screenshot shows the "PG-700" overview screen. It displays various fields for the sensor, including Name, Serial Number, Nickname, Version, Device Instance, and Sys. Instance. The "Device Instance" field is highlighted with a red box and shows the value "0". A red arrow points from this field to the bottom screenshot.

Bottom Screenshot: Device Instance Keypad
This screenshot shows the "Device Instance" keypad. The keypad displays the number "000" in a green box. The keypad includes buttons for digits 7, 8, 9, 4, 5, 6, 1, 2, 3, 0, and a green checkmark button. A red box highlights the green checkmark button.

4.3. Data Instance Setup via NavNet TZTouch2/Touch3

NavNet TZTouch2/Touch3 has ability to configure data instance for applicable FURUNO NMEA 2000 devices, i.e. IF-NMEAFI as of right now. This menu is available when using IF-NMEAFI software version 1.02 or later.

- 1) Connect an IF-NMEAFI to MFD via NMEA 2000
- 2) Home-> Setting-> Initial Setup IF-NMEAFI Setup
- 3) Select an IF-NMEAFI under “Select IF” menu found in “Initial Setup” on MFD. Please make sure to connect only one IF unit If you have two or more on the boat.
- 4) Tap a keyboard icon at “Fluid Instance”, then keypad appears.
- 5) Enter the fluid instance (0 – 14) to not conflict with other Tank sensor devices.

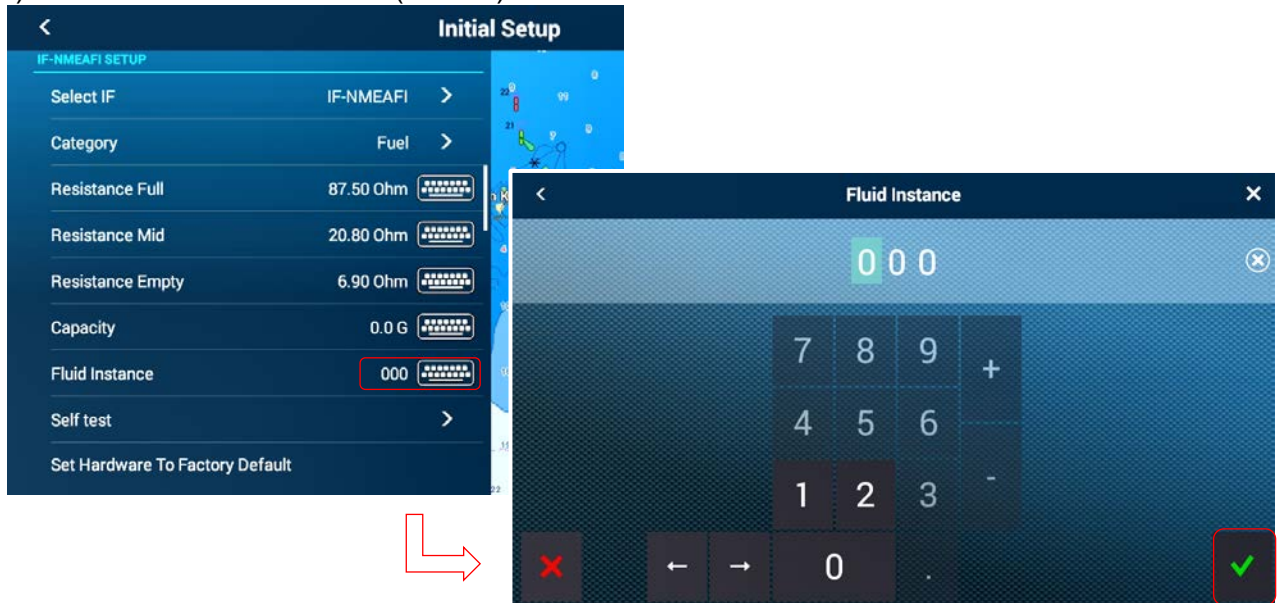

5. GENERAL INFORMATION AND REQUIRED PGNS

Multi-Function Displays and Remote displays can use NMEA2000 sensors as a direct source or calculation source for on-screen information. This following table explains general information and required PGNs. Note that the product must have the receiving capabilities for the PGN and that this is varied per product. Please refer to the operation manual to see the detailed PGN list.

Information	Required PGNs for MFDs (PGNs for Instrument displays)	Notes
Navigation Data		
Data/Time	126992 or 129033	
COG – Course Over Ground	129026 or 130577	
SOG – Speed Over Ground	129026 or 130577	
Boat Position	129029	
HDOP	129029	
DPT – Depth	128267	
HDG – Boat Heading	127250 or 130577	
CTW – Course Through Water	129026 or 130577	
STW – Speed Through Water	128259 or 130577	
Set – Current Direction	129291 or 130577	
Drift – Current Speed	129291 or 130577	
ROT – Rate of Turn	129751	
ODO – Total Cumulative Distance	129029	
Roll	127257	
Pitch	127257	
Route Information		
BTW – Bearing to Waypoint	129029 (129284)	
NEXT – Next Course	129029 (129285)	
TTG – Time to Go (VMC)	129029, 129026 or 130577	
DTW – Distance to Waypoint	129029 (129284)	
XTE – Cross Track Error	129029 (129283)	
ETA – Estimated Time Arrival	129026 and 129029 (129284, 126992 or 129033)	
TTA – Time to Arrival	129026 and 129029	
DTA – Distance to Arrival	129029	
HTS – Heading to Steer	129026 and 129029 (129284)	
VMG – Velocity Made Good	127250, 129029, 130306, 128259 or 130577	
VMC – Velocity Made Course	129026 and 129029	

Information	Required PGNs for MFD	Notes
Wind and Weather		
SST – Sea Surface Temperature	130310, 130311, 130312 or 130316	
TWD – True Wind Direction	130306	
TWA – True Wind Angle	130306	
TWS – True Wind Speed	130306	
AWA – Apparent Wind Angle	130306	
AWS – Apparent Wind Speed	130306	
Atmospheric Pressure	130310, 130311 or 130314	
Air Temperature	130310, 130311, 130312 or 130316	
Humidity	130311 or 130313	
Dew Point	130312 or 130316	
Wind Chill Temperature	130312 or 130316	
Engine and Tank		
Fuel Rate	127489	
RPM	127488	
Boost Pressure	127488	
Oil Pressure	127489	
Oil Temperature	127489	
Engine Temperature	127489	
Engine Trim	127488	
Alternator Potential	127489	
Coolant Pressure	127489	
Fuel Pressure	127489	
Engine Load	127489	
Engine Hours	127489	
Transmission Oil Pressure	127493	
Transmission Oil Temperature	127493	
Total Engine Fuel Rate	127489	
Fuel Level (or Tank Level)	127505	
Total Fuel	127505	
Fuel Time to Empty	127489 and 127505	
Fuel Distance to Empty	127489 and 127505	
Fuel Economy	127489 , 129026 or 130577	
Fuel Consumption	127489 , 129026 or 130577	
Combined NavData		
3-Axis Speed	130578	

Bold = Mandatory PGN, Nonbold = Either PGN will work