

FURUNO

GPS NAVIGATOR

Model **GP-39**



Highly accurate position fixing GPS navigator with clear color LCD

The FURUNO GPS navigator GP-39 provides accurate and reliable position fixing, thanks to a 12-channel GPS receiver combined with integrated SBAS (WAAS/EGNOS/MSAS) technology.

The GP-39 has various display modes (Plotter, Highway, Steering, NAV data, Satellite monitor and 2 user-customizable modes) on the 4.2" color LCD. Up to 3,000 points of ship track, 10,000 waypoints and 100 routes (each with up to 30 waypoints) can be stored. The waypoint and route data can be exported/imported via a USB flash drive or signal converter.

The GP-39 can be networked with a fish finder, sonar, radar or other navigation equipment for feeding highly accurate navigation data.



GPS NAVIGATOR

Model

GP-39

- ▶ Newly designed GPS core delivers enhanced position fixing accuracy
- ▶ 4.2" high-resolution color LCD
- ▶ Storage for 3,000 track points, 10,000 waypoints and 100 routes
- ▶ SBAS capable for better positioning calculations*

* SBAS is a general term for a GPS navigation system with differential correction by means of geostationary satellites. In the US, it is called WAAS (Wide Area Augmentation System), whereas in Europe and Japan, it is called EGNOS (European Geostationary Navigation Overlay System) and MSAS (MSAT Satellite-based Augmentation System), respectively.

- ▶ Share and display position information on networked equipment such as a fish finder, sonar, radar, etc.
- ▶ 7 display modes available, including 2 user-customizable modes
- ▶ Waypoint and route data can be exported/imported via a USB flash drive or signal converter
- ▶ Multi-language ready : English, French, Spanish, Chinese, Vietnamese, Malay, Indonesian and Thai

Various Displays

The GP-39 can display navigational data in a variety of formats, allowing you to select which data you want displayed.

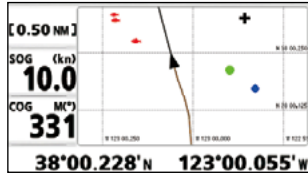

Plotter

The plotter display traces own ship's track and shows position on a 2D map. This mode presents various data and information with graphic symbols and icons.

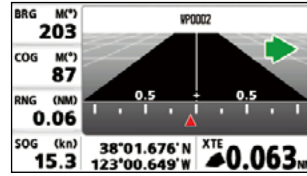

Highway

3D view of own ship's progress towards the destination (waypoint). This mode is best used for navigation where a straight-line course can be followed.

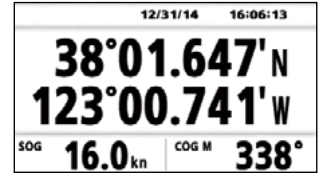

NAV data

The NAV data display shows receiver status, position in latitude and longitude, speed over ground, course over ground, date and time.



Steering

Steering information with a bearing scale is shown.

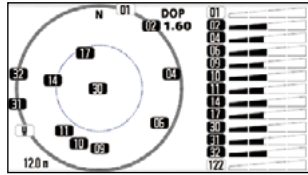

Satellite Monitor

The satellite monitor display shows the condition of GPS and GEO (SBAS) satellites. Number, bearing and elevation angle of all GPS and GEO satellites (if applicable) in view are displayed.



COG (selectable as a user display)

COG display shows course over ground in analog format and speed over ground in digital format.

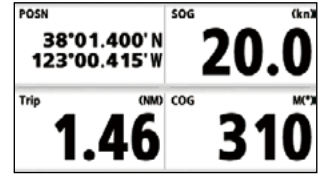

Digital (selectable as a user display)

The digital display shows one to four items of digital navigation data. You can select which data you want displayed from various sources, such as Position, COG, SOG, etc.

Interconnection with fish finder/sonar/radar

The GP-39 delivers the position information to an interfaced fish finder or sonar. Also, the GP-39 receives the TLL (Target Latitude/Longitude) sentence from networked fish finders or sonars and can display the received information. This allows you to mark fish school locations easily.

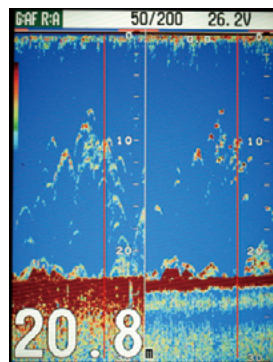

Fish finder

TLL (Target Latitude/Longitude) sentence

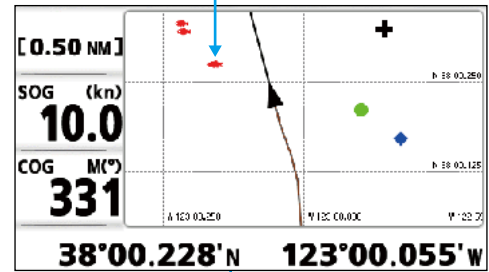

Position information

GP-39

Waypoint and route data transfer

Waypoint, route data and setting information can be exported/imported via a USB flash drive between GP-39 units. The waypoint and route data in GP-32 can be transferred to GP-39 by means of signal converter. You can backup information, or share useful information between vessels.

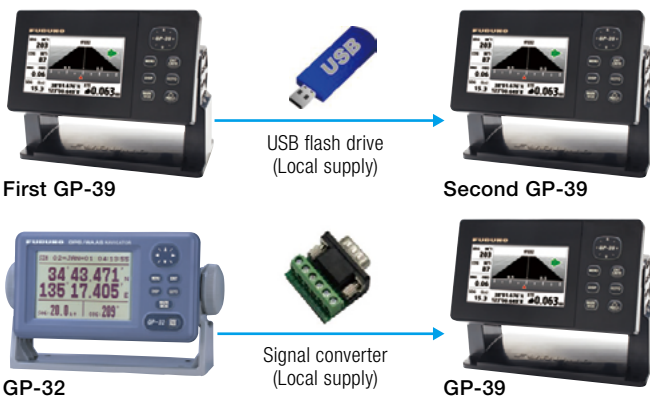

Easy to mount on/off the bracket

The improved hanger allows the display unit to be mounted or un-mounted easily. The display unit can be carried in the bag (standard supply).



SPECIFICATIONS OF **GP-39**

PRODUCT NAME GPS Navigator

DISPLAY

Screen Size 4.2" color LCD
 Effective Display Area 92 (W) x 52 (H) mm
 Pixel Number 480 (V) x 272 (H) pixels
 Display Mode Plotter, Highway, Steering, NAV Data, Satellite monitor, User Display (Digital, Speedometer, COG)
 Memory Capacity 3,000 ship's track points
 10,000 waypoints with comments
 100 routes with 30 waypoints/route
 Alarm Arrival and Anchor watch, Cross track error, Speed, WAAS (SBAS), Time, Trip

GPS/SBAS (WAAS/EGNOS/MSAS)

Receiver Type GPS: 12 channels parallel, 12 satellites tracking, C/A code, all-in-view
 SBAS: 2 channels
 Receive Frequency L1 (1575.42 MHz ± 1.023 MHz)
 Time to First Fix Cold start: 90 seconds approx.
 Tracking Velocity 1,000 kn

ACCURACY

GPS: 10 m (95% of the time, HDOP≤4)
 WAAS: 3 m (95% of the time, HDOP≤4)
 MSAS: 7 m (95% of the time, HDOP≤4)

INTERFACE

Ports NMEA0183: 1 port USB: 1 port
 Output AAM, APB, BOD, BWC, BWR, DTM, GGA, GLL, GSA, GSV, RMB, RMC, VTG, XTE, ZDA
 Input RTE, TLL

POWER SUPPLY 12-24 VDC : 0.7-0.3 A

ENVIRONMENT

Temperature Display unit: -15°C to +55°C
 Antenna unit: -25°C to +70°C
 Relative humidity 93% or less at +40°C
 Waterproofing Display unit: IP55
 Antenna unit: IP56

EQUIPMENT LIST

Standard

1. Display unit GP-39 1 unit
2. Antenna unit GPA-017 with cable 10 m 1 unit
3. Plastic bag
4. Standard spare parts and installation materials

Option

1. Mast mounting kit
2. Flush mount kit

Display Unit GP-39

Bracket type
 0.39 kg 0.86 lb

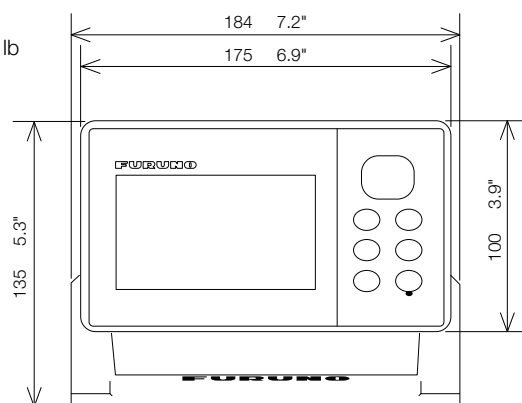

Flush mount type
 0.36 kg 0.79 lb

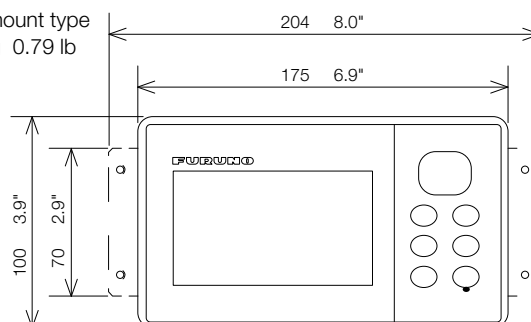

GPS Antenna

GPA-017
 0.6 kg 1.3 lb

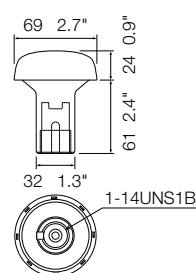

INTERCONNECTION DIAGRAM

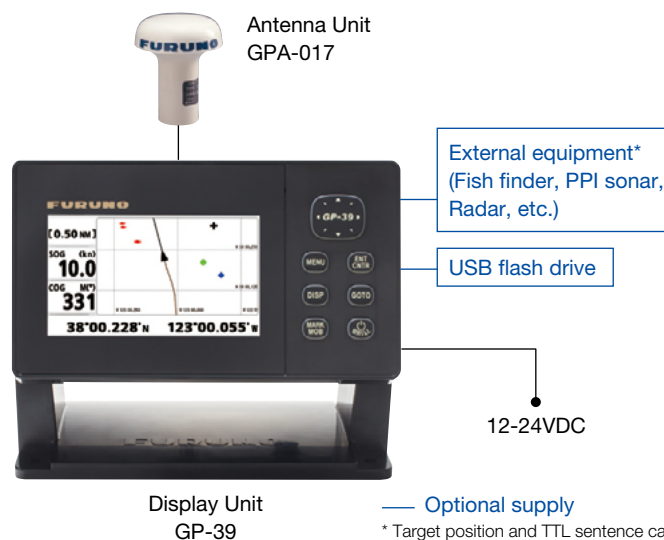

* Target position and TTL sentence can be input from the external equipment.

Beware of similar products

All brand and product names are registered trademarks, trademarks or service marks of their respective holders.