

FURUNO

INSTALLATION MANUAL NMEA DATA CONVERTER

IF-NMEA2K2

WARNING

Do not install the unit where it may get wet from rain or water splash.

Water in the unit can result in fire, electrical shock or damage the equipment.

Do not disassemble or modify the equipment.

Fire, electrical shock or serious injury can result.

CAUTION

Observe the following compass safe distances to prevent interference to a magnetic compass:

	standard compass	steering compass
IF-NMEA2K2	0.30m	0.30m

System Configuration

The NMEA Data Converter IF-NMEA2K2 converts Furuno CAN bus format data to NMEA0183 format data and vice versa.

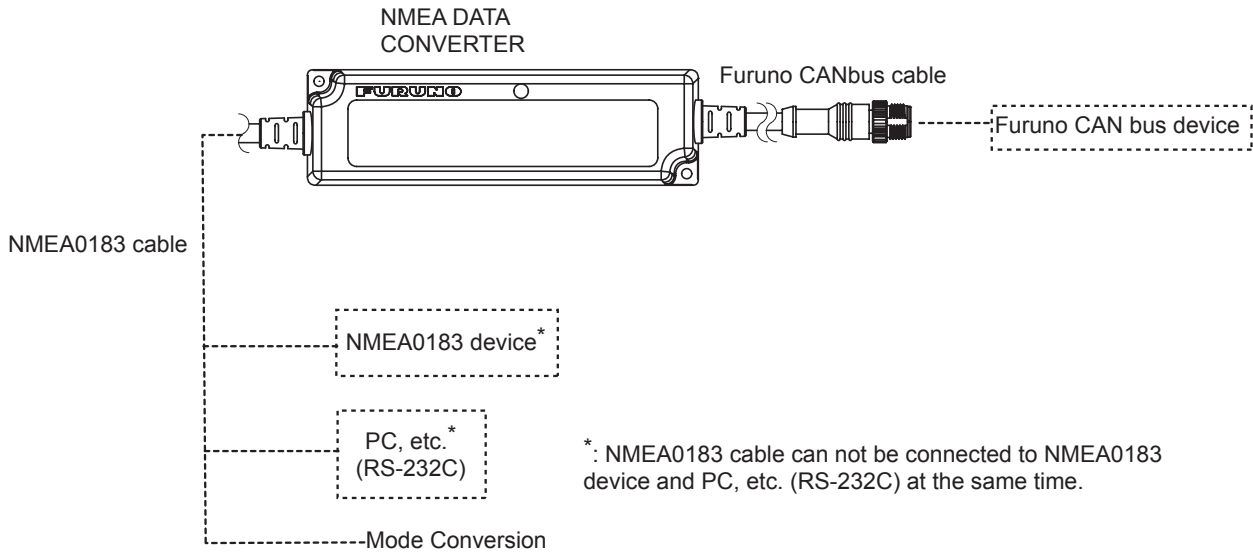

Specifications of NMEA Data Converter

Interface	Furuno CAN bus	
	NMEA0183	
Power Supply	12V 96mA (LEN: 2)	
Environmental conditions	Ambient temperature	-15°C~55°C
	Waterproofing standard	IP55* *: NMEA0183 cable terminal is not waterproof.
	Relative humidity	95% (at 40°C)
	Storage temperature	-20°C to 60°C
	Vibration resistance	IEC60945

Equipment List

Name	Type	Code No.	Qty	Remarks
NMEA Data Converter	IF-NMEA2K2	-	1	
Self Tapping Screw	3x20	000-167-940-10	2	

Installation

Mounting Considerations

- Locate the data converter well away from areas subject to water splash and rain.
- Keep the data converter out of direct sunlight because of heat that can build up inside the cabinet.

Mounting

Fix the data converter to the mounting location with two self tapping screws (3x20), referring to the outline drawing in this manual.

Wiring

Connection to Furuno CAN bus device

Connect the Furuno CAN bus cable to the Furuno CAN bus device. See “Furuno CAN bus Network Design” (TIE-00170-x) for details about CAN bus network.

Connection to NMEA0183 device

Connect the NMEA0183 signal cores to NMEA0183 device, referring to the interconnection diagram as below.

Note1: NMEA0183 cable terminal is not waterproof. Therefore, install the equipment away from areas subject to water splash and rain.

Note2: Wind vinyl tape around unused cores and fix the cores so that they do not touch other signal cores or ground.

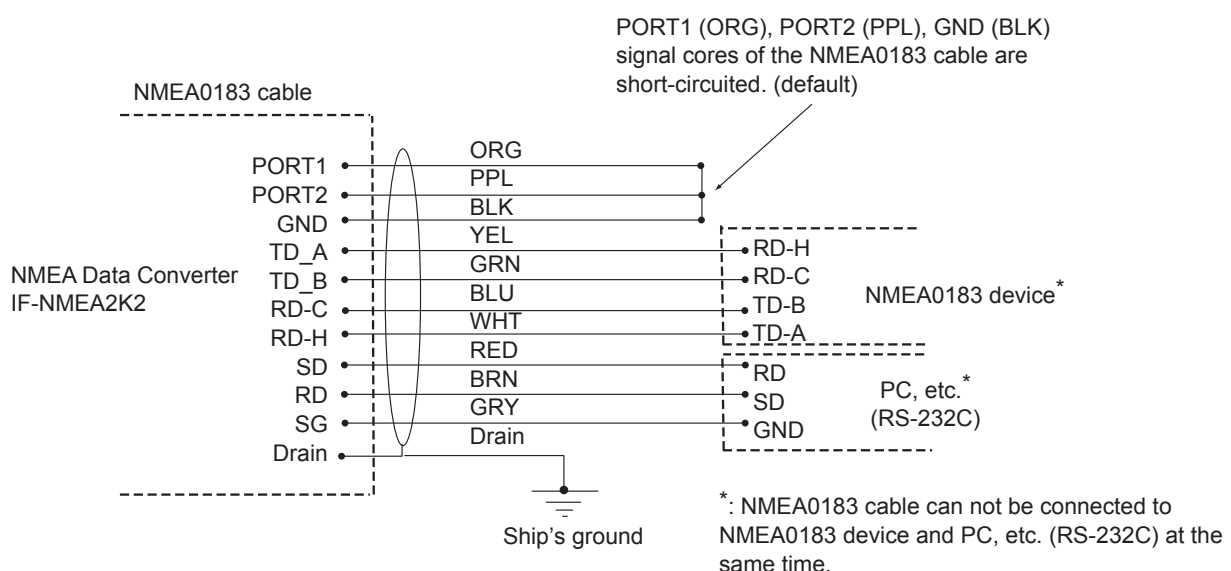

Conversion Mode

PORT1 (ORG), PORT2 (PPL), GND (BLK) signal cores of the NMEA0183 cables are short-circuited (default). By cutting the specified signal core, the conversion mode can be changed. Select the conversion mode according to the baud rate of the connected device. For connection to an AIS device, select the AIS mode.

Note1: Check the applicable checkbox on the nameplate according to the conversion mode selected.

Note2: Wind vinyl tape around unused cores and fix the cores so that they do not touch other signal cores or ground.

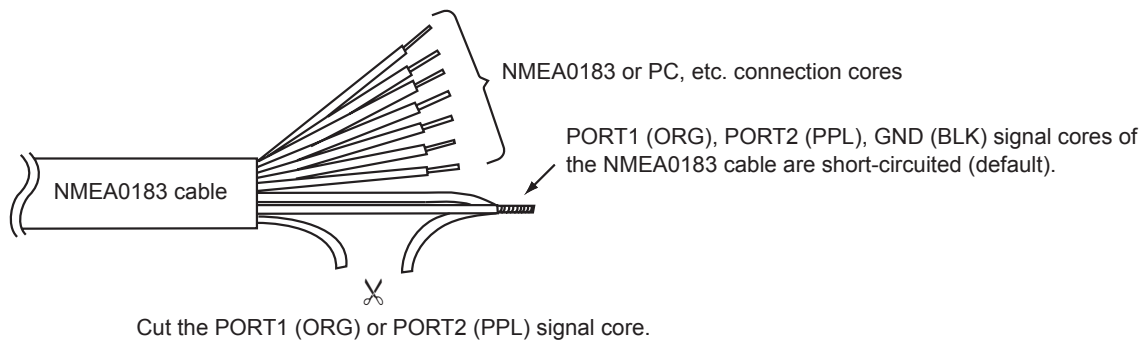

Bind signal cores with vinyl tape.

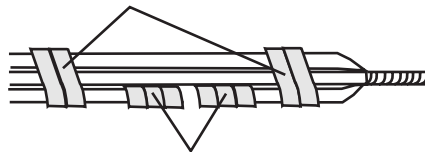

Wind vinyl tape around cores to insulate them.

Action	Conversion Mode / Baud Rate
No action*	Normal / 4800bps (default setting)
Cut the PORT1 (ORG)	High Speed / 38400bps
Cut the PORT2 (PPL)	AIS / 38400bps

*: To change the conversion mode to “Normal”, cut PORT1 and PORT2.

Turning Power On

No operation is required for the user to turn the power on. The power is supplied by Furuno CAN bus line. The Power LED (yellow) flashes when the data converter is powered.

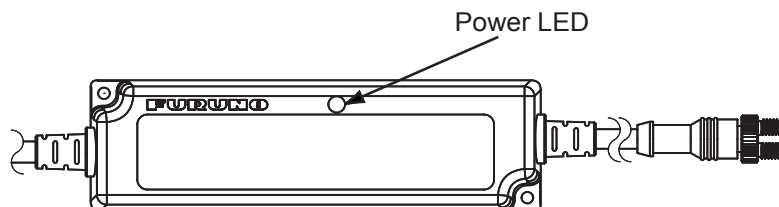

Input/Output Comparing

Furuno CAN bus → NMEA0183

Some Furuno CAN bus PGN output a number of NMEA0183 sentences.

NA means “nonperiodic”.

ID means “Message ID”.

Furuno CAN bus Input		NMEA0183 Output	Sending Cycle		
			Normal	High Speed	AIS
65280	Heave [Proprietary PGN]	PFECChve	×	100ms	×
126992	System Time	RMC	1s, 2s*	1s	×
		ZDA	1s	1s	×
127245	Rudder	RSA	×	100ms	×
127250	Vessel Heading	HDG	1s	100ms	×
		HDT	1s	100ms	×
		RMC	1s, 2s*	1s	×
		VHW	1s	1s	×
127251	Rate of Turn	ROT	×	100ms	×
127257	Attitude	PFECatt	×	100ms	×
127258	Magnetic Variation	HDG	1s	100ms	×
		RMC	1s, 2s*	1s	×
128259	Speed Through Water	RMC	1s, 2s*	1s	×
		VHW	1s	1s	×
		VTG	1s	1s	×
128267	Water Depth	DPT	1s	1s	×
128520	Tracked Target Data	TTM	×	NA	NA
129026	COG & SOG, Rapid Update	RMC	1s, 2s*	1s	×
		VTG	1s	1s	×
129029	GNSS Position Data	GGA	1s	1s	×
		RMC	1s, 2s*	1s	×
129033	Time & Date	RMC	1s, 2s*	1s	×
		ZDA	1s	1s	×
129038	AIS Class A Position Report	VDM ID: 1,2,3	×	×	NA
129039	AIS Class B Position Report	VDM ID: 18	×	×	NA
129040	AIS Class B Extended Position Report	VDM ID: 19	×	×	NA
129041	AIS Aids to Navigation (AtoN) Report	VDM ID: 21	×	×	NA
129283	Cross Track Error	RMB	1s, 2s*	1s	×
129284	Navigation Data	RMB	1s, 2s*	1s	×
129285	Navigation – Route/WP Information	RMB	1s, 2s*	1s	×
129793	AIS UTC and Data Report	VDM ID: 4	×	×	NA
129794	AIS Class A Static and Voyage Related Data	VDM ID: 5	×	×	NA
129795	AIS Addressed Binary Message	VDM ID: 6	×	×	NA
129797	AIS Binary Broadcast Message	VDM ID: 8	×	×	NA

Furuno CAN bus Input		NMEA0183 Output	Sending Cycle		
			Normal	High Speed	AIS
129798	AIS SAR Aircraft Position Report	VDM ID: 9	×	×	NA
129801	AIS Addressed Safety Related Message	VDM ID: 12	×	×	NA
129802	AIS Safety Related Broadcast Message	VDM ID: 14	×	×	NA
129808	DSC Call Information	DSC	NA	NA	NA
		DSE	NA	NA	NA
129809	AIS Class B "CS" Static Data Report, Part A	VDM ID: 24	×	×	NA
129810	AIS Class B "CS" Static Data Report, Part B	VDM ID: 24	×	×	NA
130306	Wind Data	MWD	1s	1s	×
		MWV	1s	100ms	×
130310	Environmental Parameters	MDA	1s, 5s*	1s	×
130311		MTW	1s	1s	×
130312	Temperature	MDA	1s, 5s*	1s	×
		MTW	1s	1s	×

*: When the volume of sent data exceeds the communication band, the TX interval becomes longer.

NMEA0183 → Furuno CAN bus

Some NMEA0183 sentences output a number of Furuno CAN bus PGN. The latest inputted sentence is given priority.

NA means "nonperiodic".
ID means "Message ID".

NMEA0183 Input	Furuno CAN bus Output		Sending Cycle
APB, RMB	129283	Cross Track Error	1s
	129284	Navigation Data	1s
	129285	Navigation – Route/WP Information	NA
BWC, BWR	129284	Navigation Data	1s
	129285	Navigation – Route/WP Information	NA
DPT	128267	Water Depth	1s
DSC, DSE	129808	DSC Call Information	NA
GGA, GLL, GNS	129029	GNSS Position Data	1s
HDG	127250	Vessel Heading	100ms
	127258	Magnetic Variation	1s
HDT	127250	Vessel Heading	100ms
MDA, MTW	130310	Environmental Parameters	500ms
	130312		2s
MWD, MWV	130306	Wind Data	100ms
RMC	126992	System Time	1s
	127250	Vessel Heading	100ms
	127258	Magnetic Variation	1s
	128259	Speed Through Water	1s
	129026	COG & SOG, Rapid Update	250ms
	129029	GNSS Position Data	1s
	129033	Time & Date	1s
ROT	127251	Rate of Turn	100ms

NMEA0183 Input	Furuno CAN bus Output		Sending Cycle
RSA	127245	Rudder	100ms
THS	127250	Vessel Heading	100ms
TLL	130828	Mark Position Information [Proprietary PGN]	NA
VDM	129038	AIS Class A Position Report ID: 1,2,3	NA
	129039	AIS Class B Position Report ID: 18	NA
	129040	AIS Class B Extended Position Report ID: 19	NA
	129041	AIS Aids to Navigation (AtoN) Report ID: 21	NA
	129793	AIS UTC and Data Report ID: 4	NA
	129794	AIS Class A Static and Voyage Related Data ID: 5	NA
	129795	AIS Addressed Binary Message ID: 6	NA
	129797	AIS Binary Broadcast Message ID: 8	NA
	129798	AIS SAR Aircraft Position Report ID: 9	NA
	129801	AIS Addressed Safety Related Message ID: 12	NA
	129802	AIS Safety Related Broadcast Message ID: 14	NA
	129809	AIS Class B "CS" Static Data Report, Part A ID: 24	NA
	129810	AIS Class B "CS" Static Data Report, Part B ID: 24	NA
VHW	127250	Vessel Heading	100ms
	128259	Speed Through Water	1s
VTG	128259	Speed Through Water	1s
	129026	COG & SOG, Rapid Update	250ms
XTE	129283	Cross Track Error	1s
ZDA	126992	System Time	1s
	129033	Time & Date	1s
PFECatt	127257	Attitude	100ms
PFEChe	65280	Heave [Proprietary PGN]	1s

PACKING LIST

IF-NMEA2K2

NAME	OUTLINE	DESCRIPTION/CODE No.	Q'TY
UNIT			
NMEA DATA CONVERTER		IF-NMEA2K2	1
		000-020-511-00	
INSTALLATION MATERIALS			
SELF TAPPING SCREW		3X20 SUS304	2
		000-167-940-10	
DOCUMENT			
INSTALLATION MANUAL (JP/EN)		IMC-44591-*	1
		000-176-101-1*	

TABLE 1

(mm) DIMENSION	(mm) TOLERANCE
$L \leq 50$	± 1.5
$50 < L \leq 100$	± 2.5
$100 < L \leq 500$	± 3

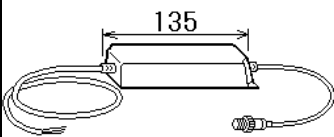
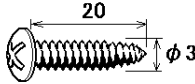
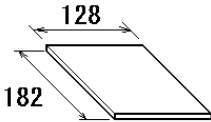
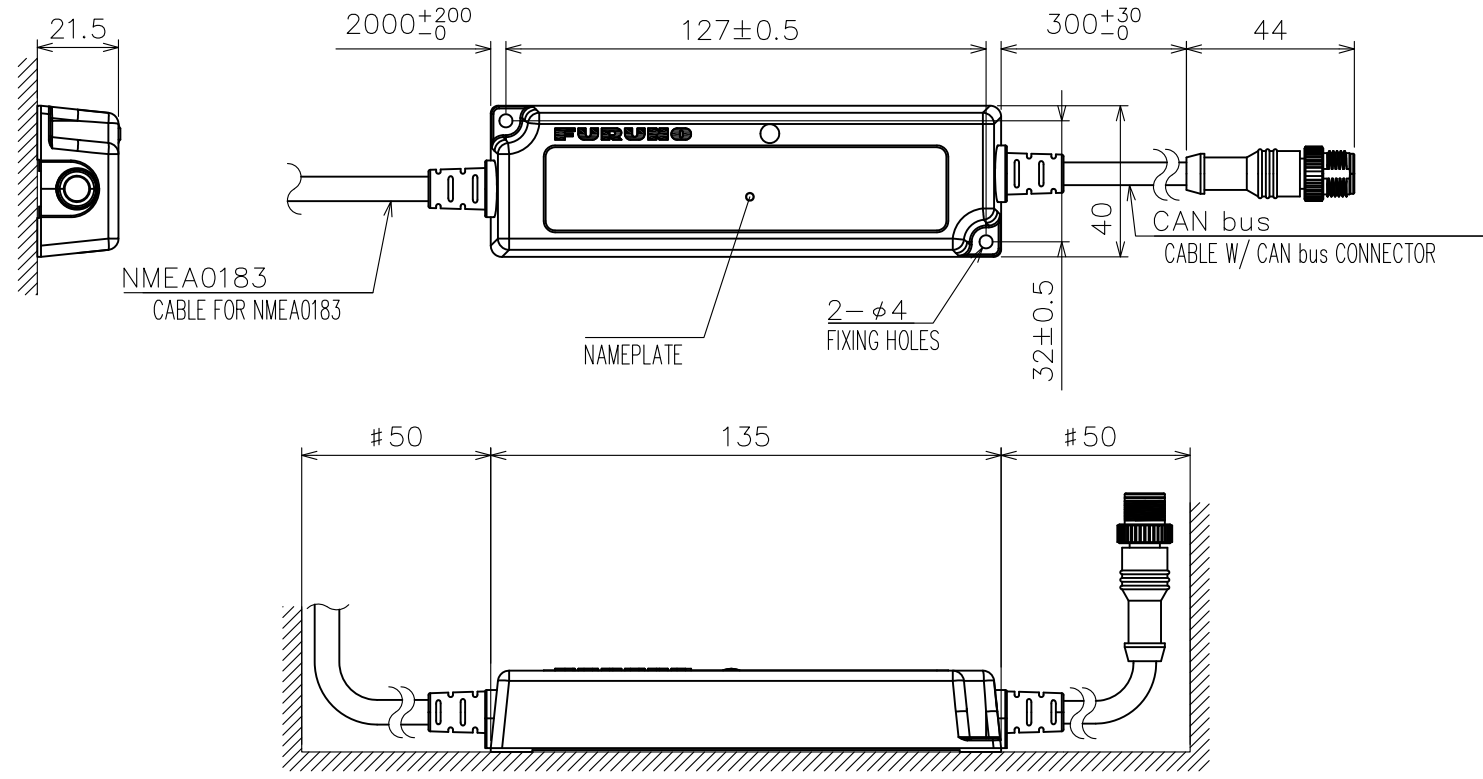

- NOTE
1. TABLE 1 INDICATES TOLERANCE OF DIMENSIONS WHICH IS NOT SPECIFIED.
 2. #: MINIMUM SERVICE CLEARANCE.
 3. USE TAPPING SCREWS ϕ 3x20 FOR FIXING THE UNIT.

DRAWN	26/Jan/2012	T.YAMASAKI	TITLE	IF-NMEA2K2	
CHECKED	26/Jan/2012	H.MAKI		NMEA	
APPROVED					
SCALE	1/2	MASS	0.35 \pm 10%	NAME	NMEA DATA CONVERTER
DWG.No.	C4459-G03-B		REF.No.	14-080-100G-1	OUTLINE DRAWING

1

2

3

4

A

B

C

NETWORK EQUIPMENT

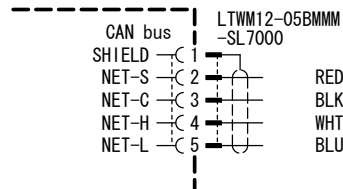

RED
BLK
WHT
BLU

0.3m

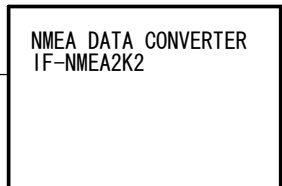

2m

ORG
PPL
BLK
YEL
GRN
BLU
WHT
RED
BRN
GRY
DRAIN

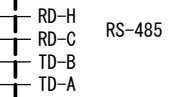
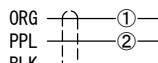

RS-485
NAV EQUIPMENT
(NMEA0183 Ver3.0)

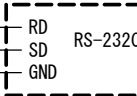

RS-232C

CUTOFF LINE No.	COLOR	MODE
DEFAULT		NORMAL
① : PORT 1	ORG	HIGH SPEED
② : PORT 2	PPL	AIS

CUTOFF BOTH LINE: SAME AS DEFAULT SETTING

DRAWN 12/Jan/2012 T. YAMASAKI		TITLE 1F-NMEA2K2	
CHECKED 12/Jan/2012 H. MAKI			
APPROVED			
SCALE	MASS kg	NAME NMEA DATA CONVERTER	
DWG. No. C4459-C02- B	REF. No. 14-080-5000-0	INTERCONNECTION DIAGRAM	