

FURUNO

OPERATOR'S MANUAL

LOUD HAILER

Model

LH-5000

IMPORTANT NOTICES

General

- This manual has been authored with simplified grammar, to meet the needs of international users.
- The operator of this equipment must read and follow the descriptions in this manual. Wrong operation or maintenance can cancel the warranty or cause injury.
- Do not copy any part of this manual without written permission from FURUNO.
- If this manual is lost or worn, contact your dealer about replacement.
- The contents of this manual and equipment specifications can change without notice.
- The example screens (or illustrations) shown in this manual can be different from the screens you see on your display. The screens you see depend on your system configuration and equipment settings.
- Save this manual for future reference.
- Any modification of the equipment (including software) by persons not authorized by FURUNO will cancel the warranty.
- The following concern acts as our importer in Europe, as defined in DECISION No 768/2008/EC.
 - Name: FURUNO EUROPE B.V.
 - Address: Ridderhaven 19B, 2984 BT Ridderkerk, The Netherlands
- All brand and product names are trademarks, registered trademarks or service marks of their respective holders.

How to discard this product

Discard this product according to local regulations for the disposal of industrial waste. For disposal in the USA, see the homepage of the Electronics Industries Alliance for the correct method of disposal.

How to discard a used battery

Some FURUNO products have a battery(ies). To see if your product has a battery, see the chapter on Maintenance. Follow the instructions below if a battery is used. Tape the + and - terminals of battery before disposal to prevent fire, heat generation caused by short circuit.

In the European Union

The crossed-out trash can symbol indicates that all types of batteries must not be discarded in standard trash, or at a trash site. Take the used batteries to a battery collection site according to your national legislation and the Batteries Directive 2006/66/EU.



In the USA

The Mobius loop symbol (three chasing arrows) indicates that Ni-Cd and lead-acid rechargeable batteries must be recycled. Take the used batteries to a battery collection site according to local laws.

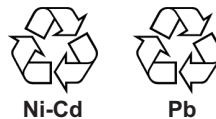

In the other countries

There are no international standards for the battery recycle symbol. The number of symbols can increase when the other countries make their own recycle symbols in the future.



SAFETY INSTRUCTIONS

The installer and user must read the applicable safety instructions before attempting to install or operate the equipment.



WARNING

Indicates a potentially hazardous situation which, if not avoided, could result in death or serious injury.



CAUTION

Indicates a potentially hazardous situation which, if not avoided, may result in minor or moderate injury.



Warning, Caution



Prohibitive Action



Mandatory Action



WARNING



Do not open the equipment.

Only qualified personnel can work inside the equipment.



Do not disassemble or modify the equipment.

Fire, electrical shock or serious injury can result.



Turn off the power immediately if the equipment is emitting smoke or fire.

Fire or electrical shock can result if the power is left on.



Turn off the power immediately if water leaks into the equipment or an object is dropped inside the equipment.

Continued use can cause fire or electrical shock.



Turn off the power immediately if you feel the equipment is acting abnormally.

If the equipment is hot to the touch or is emitting strange noises, turn off the power immediately and contact your dealer for advice.



Do not operate the equipment with wet hands.

Electrical shock can result.



Do not place liquid-filled containers on the top of the equipment.

Electrical shock can result.



WARNING



Use the proper fuse.

Use of a wrong fuse can damage the equipment and may cause fire.



Keep heater away from equipment.

Heat can alter equipment shape and melt the power cord, which can cause fire or electrical shock.



CAUTION



Do not connect/disconnect the signal cable while turning the power on.

The unit may be damaged.



A magnetic compass may receive interference if it is placed too close to this unit. Observe the compass safe distances shown below to prevent interference to a magnetic compass.

	Standard compass	Steering compass
Loud Hailer LH-5000	0.45 m	0.30 m
Intercom Speaker ISP-5000	2.25 m	1.50 m



Do not use high-pressure cleaners to clean this equipment.

This equipment has the waterproof rating outlined in the specifications, at the back of this manual. However, the use of high-pressure cleaning equipment can cause water ingress, resulting in damage to, or failure of, the equipment.

Contents

Foreword	1
System Configuration	2
Equipment List	3
1. Installation	5
1.1 Installing the Loud Hailer	5
1.2 Installing the Microphone	8
1.3 Installing the Intercom Speaker (Optional).....	9
1.4 Installing the Extension Cable (Optional).....	11
1.5 Connecting the Cable	13
1.5.1 Understanding the Cable	13
1.5.2 Connecting the Pig-tail Cable and Power Cord	15
1.5.3 Connecting the Microphone and Extension Cable	17
1.5.4 Connecting the Ground Cable	18
2. Operation Overview	20
2.1 Product Controls	20
2.2 Turning the Power On/Off	21
2.3 Adjusting Key Backlight	22
2.4 Adjusting the Contrast	22
2.5 Adjusting the Volume	22
2.6 Calling All Speakers	23
2.7 Calling All Intercom Speakers	23
2.8 Calling a Specific Intercom Speaker	24
2.9 Receiving a Call from an Intercom Speaker	25

2.10 Hailing by Voice	27
2.11 Sounding Warning Signals	28
2.12 Transmitting the Auxiliary Signal.....	32
2.13 Setting the Alarm Mode	33
2.14 Setting the Siren Mode	35
2.15 Setting the Key Beep	36
2.16 Renaming the Intercom Station	37
2.17 Selecting the Speaker.....	37
2.18 Performing the Self-test	38
2.19 Restoring the Factory Settings	38
3. Maintenance and Troubleshooting.....	41
3.1 Preventive Maintenance	41
3.2 Replacing the Fuse.....	41
3.3 Troubleshooting	42
Specifications	43
Packing List	46
Outline Drawings.....	50
Service Space Information	52
Interconnection	54
Menu Tree	55
Flush Mount Template	56

Foreword

FURUNO LH-5000 loud hailer (LH-5000) is designed for a wide variety of ships, requiring high quality onboard communications under almost any circumstances.

Features

- Hail, intercom, and alarm functions available
- Built-in high quality speaker
- Eight warning signals
- Auxiliary audio input

System Configuration

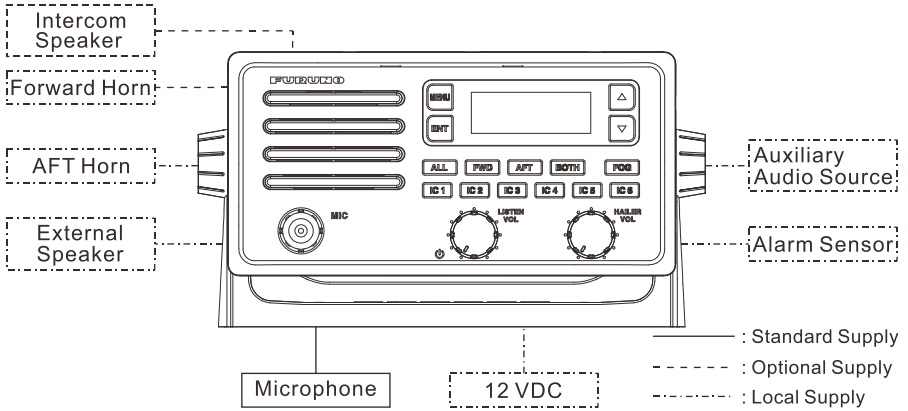

Equipment List

Standard Supply:

Part	Name	Type	Qty	Remarks
Main body	Loud Hailer	LH-5000	1	See packing list for details
	Microphone	MIC-5000	1	
Accessories	Hanger	/	1	
	Hanger Knob	/	2	
	Microphone Hanger	/	1	
Installation Materials	Cushion	/	1	
	Template	/	1	
	Tapping Screw (ST4.0 x 16)	/	3	
	Tapping Screw (PA4.0 x 25)	/	4	
Document	Operator's Manual	/	1	
	Packing List	/	1	
Spare parts	Fuse (250VAC 15A)	/	2	

Optional Supply:

Part	Name	Type	Qty	Outline	Remarks
Option	Intercom Speaker (with Hanger)	ISP-5000	1	See packing list for details	Max.6
	Extension Cable for microphone	EX-CBL-LH 5M	1		5 m

1. Installation

1.1 Installing the Loud Hailer

For desktop mounting

Step 1 Put the hanger in a location where it is easy to install the LH-5000 Loud Hailer.

Step 2 Fix the hanger with four screws.

Step 3 Set the loud hailer to the hanger.

Step 4 Tighten the knob bolts on both sides of the hanger.

Step 5 Connect the intercom speaker to the loud hailer using the color-coded signal cable.

Make sure that every signal cable is firmly connected.

Step 6 Attach the microphone to the front microphone connector on the loud hailer.

Step 7 Connect the power cord properly.

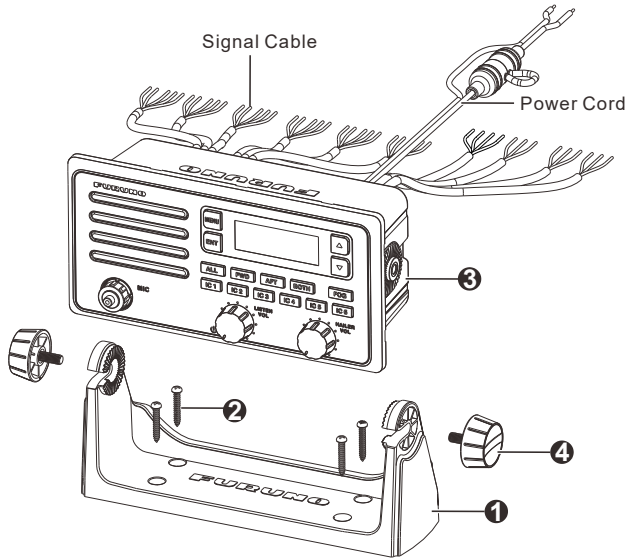

1	Hanger	3	Loud hailer
2	Tapping screw(PA4.0 x 25)	4	Hanger knob

For flush mounting

Step 1 Determine the position of installation holes according to the marking template and drill the hole.

Step 2 Pry off the frame from the front panel.

Step 3 Paste the cushion on the back of the front panel with the double-side tape on the cushion.

Step 4 Connect the intercom speaker to the loud hailer using the color-coded signal cable.

Make sure that every signal cable is firmly connected.

Step 5 Place the LH-5000 Loud Hailer in the hole and fix it with four screws.

Step 6 Attach the microphone to the front microphone connector on the loud hailer.

Step 7 Connect the power cord properly.

Step 8 Mount the frame.

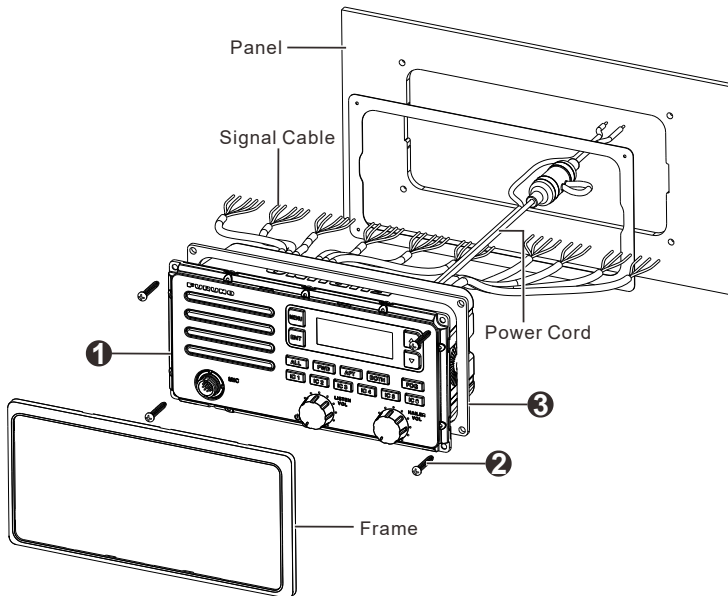

1	Loud hailer	3	Cushion
2	Tapping screw (PA4.0 x 25)	\	\

Note

Tape the unused cables to prevent short.

1.2 Installing the Microphone

Step 1 Determine a location where it is easy to install hanger.

Step 2 Fix the hanger with three screws.

Step 3 Place the microphone into the hanger.

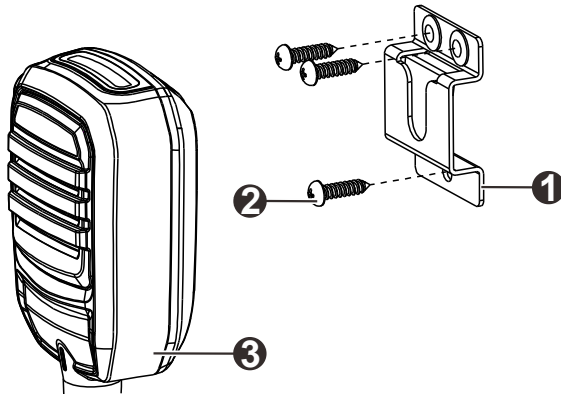

1	Microphone hanger	3	Microphone
2	Tapping screw (ST4.0 x 16)	\	\

1.3 Installing the Intercom Speaker (Optional)

For desktop mounting

- Step 1** Put the hanger in a location where it is easy to install the intercom speaker.
- Step 2** Fix the hanger with four screws.
- Step 3** Set the intercom speaker to the hanger.
- Step 4** Tighten the knob bolts on both sides of the hanger.
- Step 5** Connect the signal cable.

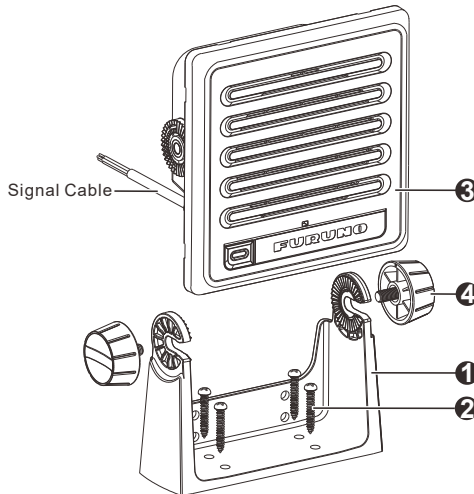

1	Hanger	3	Intercom speaker
2	Tapping screw (PA4.0 x 25)	4	Hanger knob

For flush mounting

- Step 1** Determine the position of installation holes according to the marking template and drill the hole.
- Step 2** Pry off the frame from the front panel.
- Step 3** Paste the cushion on the back of the front panel by the double-side tape on the cushion.
- Step 4** Place the intercom speaker in the hole and fix it with four screws.
- Step 5** Connect the intercom speaker to the loud hailer using the color-coded signal cable.
- Make sure that every signal cable is firmly connected.
- Step 6** Mount the frame.

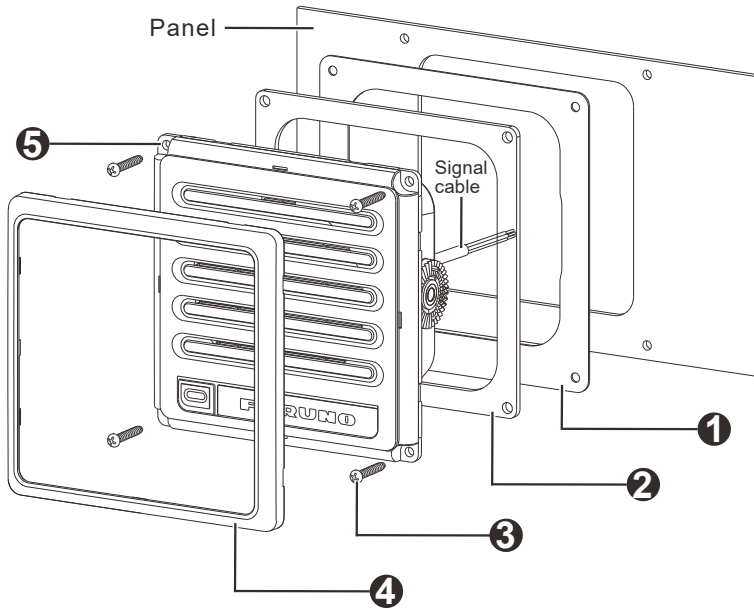

1	Template	4	Frame
2	Cushion	5	Intercom speaker
3	Tapping screw (PA4.0 x 25)	\	\

1.4 Installing the Extension Cable (Optional)

For thru-wall mounting

Step 1 Drill a round or square hole on the ship panel.

The diameter of the hole ranges from 20 mm to 25 mm.

Step 2 Thread the extension cable through the hole.

Step 3 Place the seal, cable holder, and waterproof cover sequentially around the extension cable.

Step 4 Fasten the nut.

Step 5 Fasten the three screws.

Step 6 Put the cover on the extension cable and tighten it.

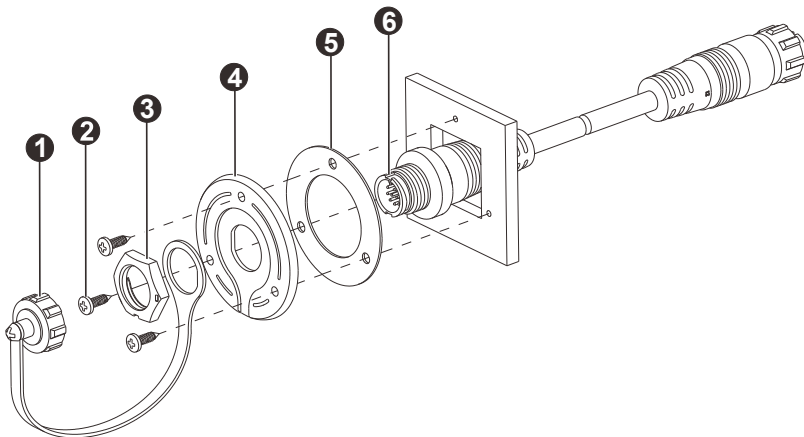

1	Waterproof cover	4	Cable holder
2	Tapping screw (PA3.0 x 10)	5	Seal
3	Nut	6	Extension cable

1.5 Connecting the Cable

The following diagram illustrates how to connect the cable.

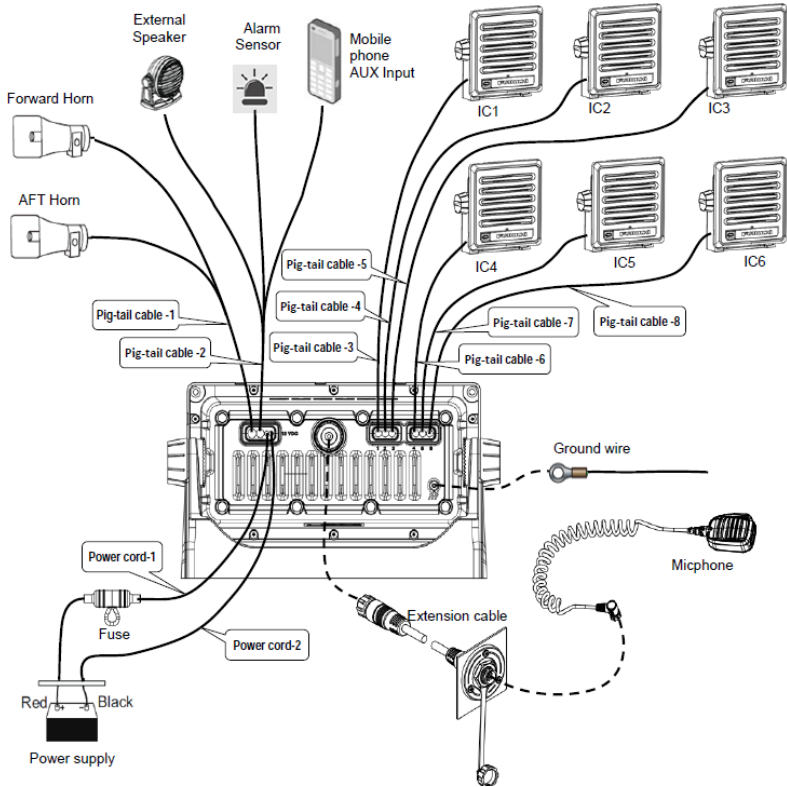

1.5.1 Understanding the Cable

Before you connect the cable, it is recommended to know the corresponding relationship about cables.

- For pig-tail cable-1

Wire color	Function	Remark
PURPLE	FWD+	Forward horn (+) output
GRAY	FWD-	Forward horn (-) output
BROWN	Chassis GND	Forward horn chassis GND
PURPLE	AFT+	AFT horn (+) output
GRAY	AFT-	AFT horn (-) output
BROWN	Chassis GND	AFT horn chassis GND

- For pig-tail cable-2

Wire color	Function	Remark
PURPLE	EXT SPK+	External speaker (+) output
GRAY	EXT SPK -	External speaker (-) output
BROWN	Chassis GND	External speaker chassis GND
RED	ALM	Alarm signal input
WHITE	ALM GND	Alarm signal GND
YELLOW	AUX	Auxiliary signal input
GREEN	AUX GND	Auxiliary signal GND

- For pig-tail cable- 3 to 8

Wire color	Function	Remark
PURPLE	SPK+	Intercom speaker (+) output
GRAY	SPK-	Intercom speaker (-) output
BROWN	Chassis GND	Intercom speaker chassis GND
GREEN	CALL	Call signal input
WHITE	GND	Call signal GND

- For power cord-1 to 2

Wire color	Function	Remark
RED	DC_IN (+)	DC power (+) input, 12 V DC
BLACK	DC_IN (-)	DC power (-) output

1.5.2 Connecting the Pig-tail Cable and Power Cord

Both the pig-tail cable and power cord are connected similarly.

Step 1 Remove the outer sheath at one end of the cable on the unit.

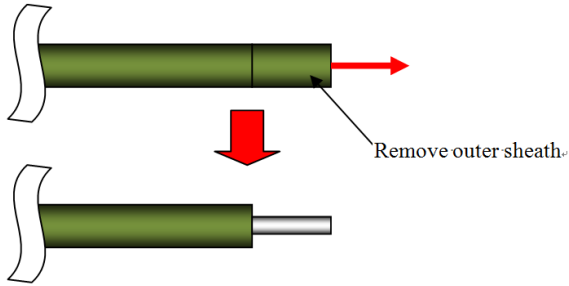

Step 2 Referring to the figure below, place heat shrink tubes on the wires, and then solder the correction point.

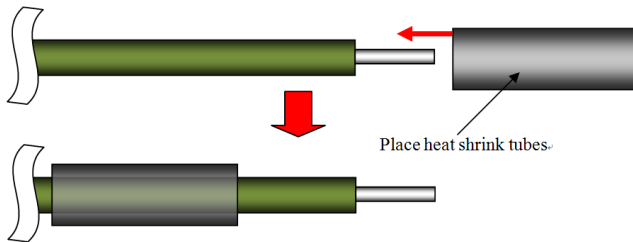

Step 3 Move the heat shrink tubes to the soldered correction, and then apply heat to the tubes.

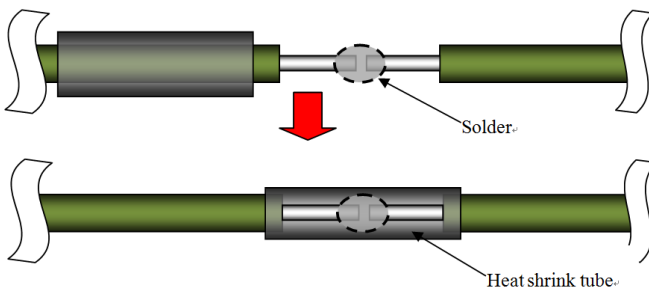

Step 4 Secure the cable with insulation tape.

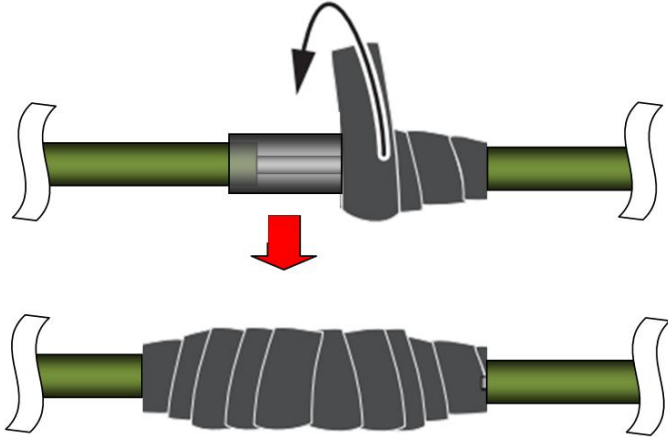

1.5.3 Connecting the Microphone and Extension Cable

Step 1 Remove the protective cover of the rear microphone connector.

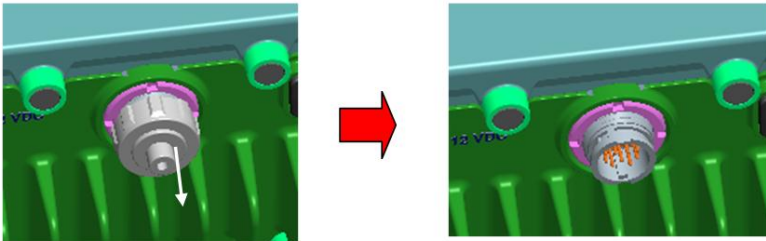

Step 2 Connect one end of the extension cable to the connector on the unit and tighten it.

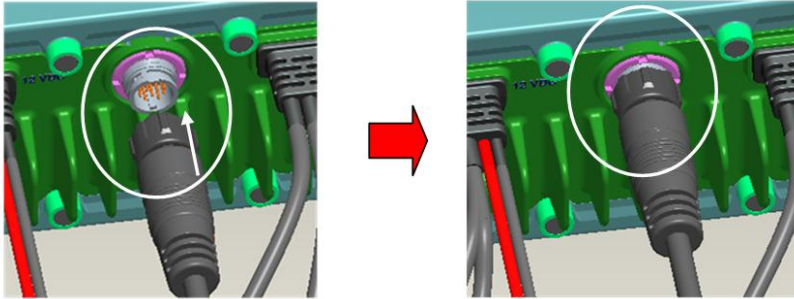

Step 3 Secure the other end of the extension cable to the panel.

Step 4 Connect the microphone to the connector of extension cable.

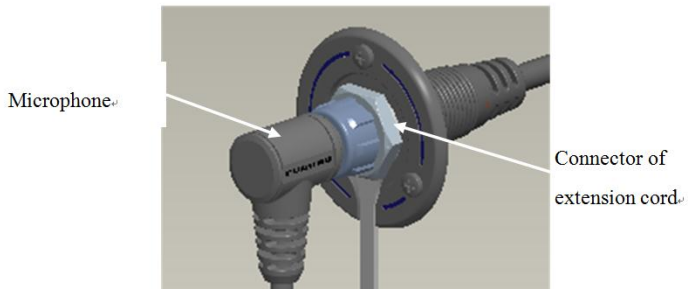

1.5.4 Connecting the Ground Cable

Step 1 Loosen the screw on the rear back of the unit.

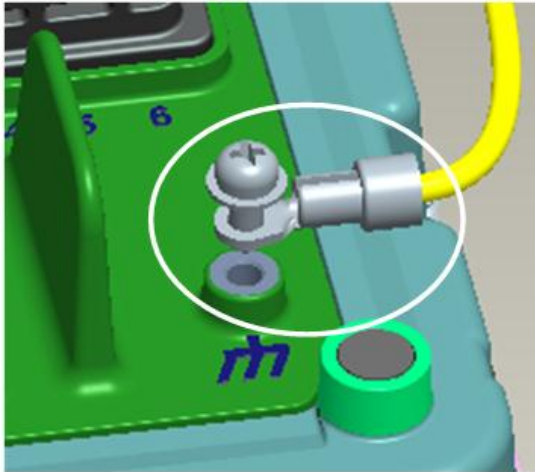

Step 2 Place the grounding wire on the screw.

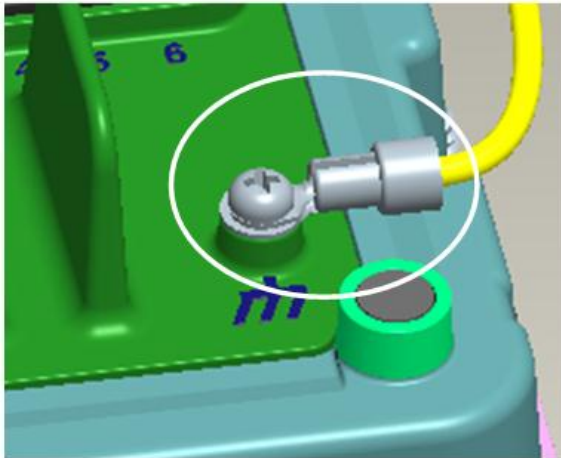

Step 3 Tighten the screw again.

2. Operation Overview

2.1 Product Controls

Front Panel

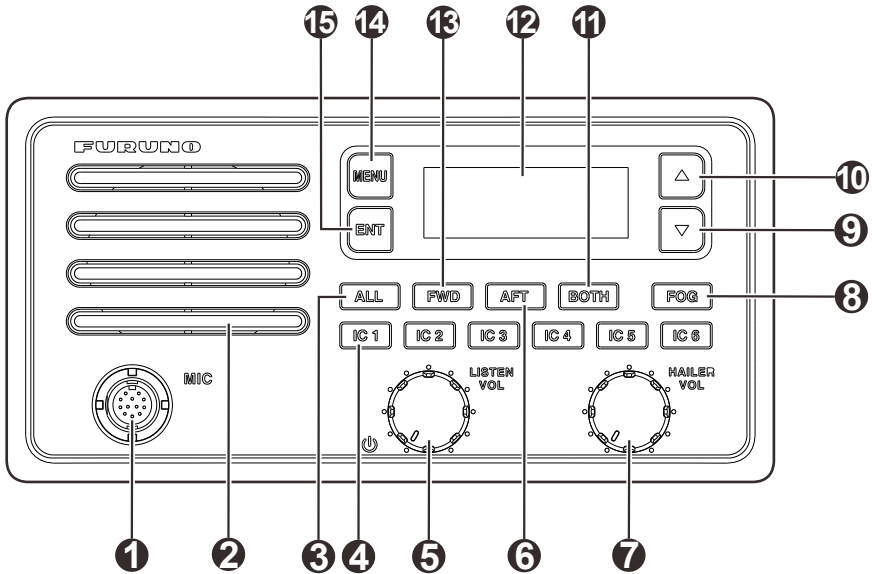

No.	Part Name	No.	Part Name
1	Front Microphone Connector	9	Down Key
2	Speaker	10	Up Key
3	ALL Key	11	Both Key
4	Intercom Selector Keys (IC1-IC6)	12	LCD
5	Listen Volume Control/Power On-Off	13	Forward Key
6	AFT Key	14	Menu Key
7	Hailer Volume Control	15	Enter Key
8	Fog Key	/	/

Rear Panel

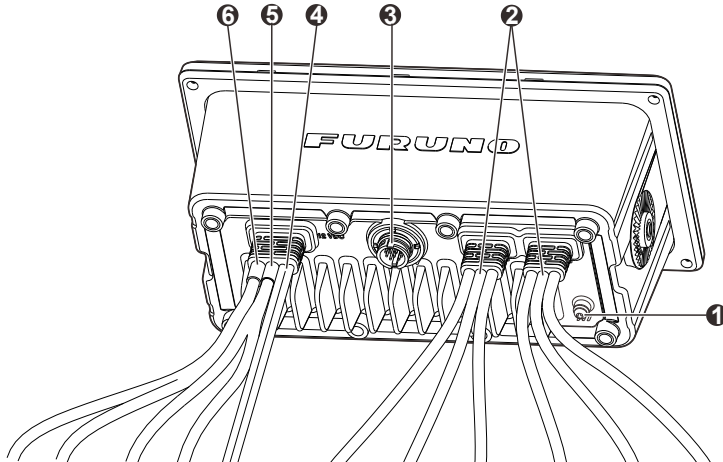

No.	Part Name	No.	Part Name
1	Ground Terminal	4	DC Power Input
2	IC Speaker Signal Cable (IC1-IC6)	5	External Speaker/Alarm/AUX Signal Cable
3	Rear Microphone Connector	6	Hailer Speaker Cable

2.2 Turning the Power On/Off

To turn on the LH-5000, rotate the **Listen Volume Control/Power On-Off** knob clockwise.

To turn off the LH-5000, rotate the **Listen Volume Control/Power On-Off** knob counterclockwise.

2.3 Adjusting Key Backlight

- Step 1** Press **MENU** key on the front panel.
- Step 2** Press **ENT** key to access the “DIMMER” interface on the screen.
- Step 3** Press **Up** or **Down** key to increase or decrease the brightness of the keys on the front panel.
- Step 4** Press **ENT** key to confirm your settings.



If you do not adjust the brightness within 60 seconds, the LH-5000 returns to the previous mode automatically.

2.4 Adjusting the Contrast

- Step 1** Press the **MENU** key on the front panel.
- Step 2** Press the **Up** or **Down** key to select "CONTRAST" and press the **ENT** key.
- Step 3** Press the **Up** or **Down** key to increase or decrease the contrast of the screen.
- Step 4** Press **ENT** key to confirm your settings.

2.5 Adjusting the Volume

To adjust the volume from the internal or external speaker, rotate the **Listen**

Volume Control knob.

To adjust the volume from the intercom or horn speaker, rotate the **Hailer Volume Control** key.

2.6 Calling All Speakers

All speakers include all the six intercom speakers and both horn speakers.

Step 1 Press the **ALL** key on the front panel.

The following information appears on the screen.



Step 2 Press and hold the **PTT** key on the microphone and speak into the microphone.

The following information appears on the screen.



Step 3 Release the **PTT** key to receive.

2.7 Calling All Intercom Speakers

All intercom speakers indicate the six intercom speakers including IC 1, IC 2, IC 3, IC 4, IC 5, and IC 6.

Step 1 Press and hold any key from **IC1** to **IC6** on the front panel.

All the keys from **IC1** to **IC6** light red and the following information appears on the screen.



Step 2 Press and hold the **PTT** key on the microphone and speak into the microphone.

The following information appears on the screen.



Step 3 Release the **PTT** key to receive.

Step 4 After finishing your conversation, press the **ALL** key to return to the home screen.

2.8 Calling a Specific Intercom Speaker

Step 1 Press any key from **IC1** to **IC6** on the front panel.

The selected key lights red and a short tone sounds from the corresponding intercom speaker. Also the following information appears on the screen.

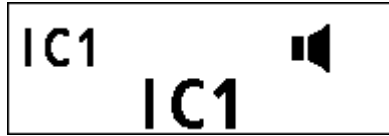

Note

The intercom speaker name appears in the bottom line of LCD.

To rename the name, see 2.16 Renaming the Intercom Station.

Step 2 Press and hold the **PTT** key on the microphone and speak into the microphone.

The following information appears on the screen.

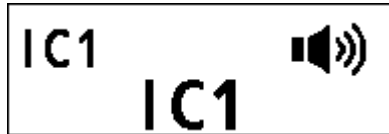

Step 3 Release the **PTT** key to receive.

Step 4 After completing your conversation, press the **ALL** key to return to the home screen, or press the same selected key (IC1-IC6) to back to previous mode.

2.9 Receiving a Call from an Intercom Speaker

When one or multiple calls from an intercom speaker arrive, you can receive the call manually or automatically. If only one call was received, IC number and IC name will flash on the screen. When multiple calls arrive, the IC name and IC number will appear in turn every four seconds.

Automatically receiving a call from a single speaker in ALL mode only

Step 1 Press and hold the **PTT** key on the microphone to answer the call in **ALL** mode.

The LH-5000 automatically switches to the calling intercom speaker.

Step 2 After completing your conversation, press the **ALL** key to return to the home screen, or press the same selected key (**IC1-IC6**) to back to previous mode.

Automatically receiving calls from multiple speakers

When multiple incoming calls arrive simultaneously, the LH-5000 automatically handles the call in ascending order of the intercom station number. For example, the LH-5000 receives calls from IC1 and IC 5 at the same time, it will handle the call from IC1 first and then the call from IC 5.

Step 1 In the home screen, press and hold the **PTT** key on the microphone to answer the call.

The LH-5000 automatically receives the call from the speaker whose number is the smallest.

Step 2 After completing your conversation, press the **ALL** key to return to the home screen.

Step 3 Press and hold the **PTT** key again on the microphone again.

The LH-5000 automatically receives the call from another speaker whose number is the smaller.

Step 4 After completing your conversation, press the **ALL** key to return to the home screen, or press the same selected key (**IC1-IC6**) to back to previous mode.

Manually receiving a call from a single station

Step 1 Press the selected key (IC1–IC6) and hold the **PTT** key on the microphone to answer the call.

Only in ALL mode, you can perform this function.

Step 2 Release the **PTT** key on the microphone to receive.

Step 3 After completing your conversation, press the **ALL** key to return to the home screen, or press the same selected key (**IC1-IC6**) to back to previous mode.

2.10 Hailing by Voice

Step 1 Press **AFT**, **FWD**, or **BOTH** key to select the horn speaker(s).

For example, if you press the **FWD** key, this key lights red and the following information appears on the screen.



Step 2 Press and hold the **PTT** key on the microphone and speak into the microphone.



Step 3 Release the **PTT** key to receive.

The speaker(s) works as microphone(s).

Step 4 After speaking, press the **ALL** key to return to the home screen.

2.11 Sounding Warning Signals

The LH-5000 has eight warning signals including manual, yelp, underway, stopped, sailboat, towed, anchored, and aground. The manual and yelp signals are sounded when you press and hold the **PTT** key on the microphone. However, the remaining warning signals are given when you press **ENT** key on the front panel.

The table lists the function of the warning signal.

Warning Signal	Function	Remarks
Manual	For ship passing.	The lengths and timing of the horn blasts are controlled by pressing and holding the PTT key on the microphone.
Yelp	For emergency siren.	

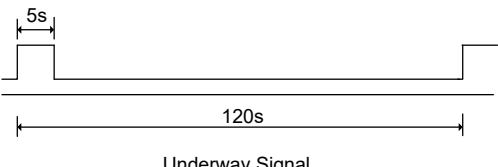
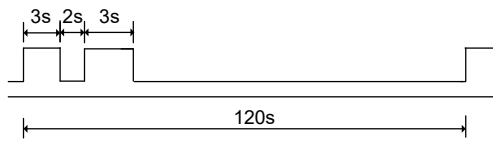
Warning Signal	Function	Remarks
Underway	For power-driven vessels underway.	<p>One 5-second blast at 120-second interval.</p>  <p style="text-align: center;">Underway Signal</p>
Stopped	For power-driven vessel that is stationary.	<p>Two 3-second blasts, with a 2-second interval between each blast, repeated every 120 seconds.</p>  <p style="text-align: center;">Stopped Signal</p>
Sailboat	For sailboats, tug boats and tow boats underway.	<p>One 3-second blast, followed by one 2-second interval, one 1-second blast, one 2-second interval and one 1-second blast. Repeated every 120 seconds.</p>

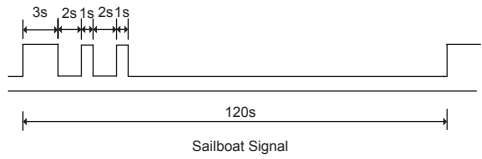
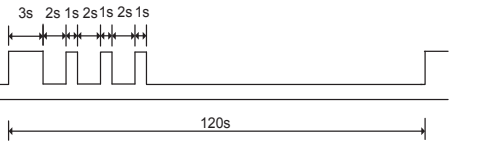
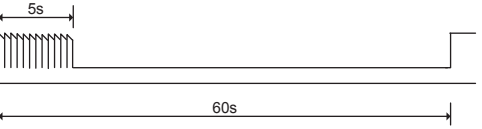
Warning Signal	Function	Remarks
		 <p>The diagram shows a sequence of four pulses: a 3-second pulse, a 2-second interval, a 1-second pulse, a 2-second interval, and another 1-second pulse. This sequence is repeated every 120 seconds. The label 'Sailboat Signal' is centered below the 120s interval line.</p>
Towed	For vessels under tow.	<p>One 3-second blast, followed by one 2-second interval, one 1-second blast, one 2-second interval, one 1-second blast, one 2-second interval, and one 1-second blast. Repeated every 120 seconds.</p>  <p>The diagram shows a sequence of six pulses: a 3-second pulse, a 2-second interval, a 1-second pulse, a 2-second interval, a 1-second pulse, and another 2-second interval. This sequence is repeated every 120 seconds. The label 'Towed Signal' is centered below the 120s interval line.</p>
Anchored	For vessels at anchor.	<p>A rapidly ringing bell tone sounds for about 5 seconds, repeated at an interval of 60 seconds.</p>  <p>The diagram shows a 5-second period of rapid ringing, followed by a 60-second interval. The label 'Anchored Signal' is centered below the 60s interval line.</p>

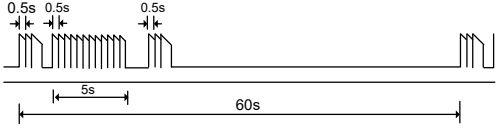
Warning Signal	Function	Remarks
Aground	For vessels aground.	<p>Two bell tones of 0.5 seconds, a bell tone of 1.5 second followed by a rapidly ringing bell tone for a duration of about 5 seconds, followed by two bell tone of 0.5 seconds and a bell tone of 1.5 seconds. Repeated once every 60seconds.</p>  <p style="text-align: center;">Aground Signal</p>

Manually Sending a warning signal

Step 1 Press the **FOG** key on the front panel.

The **FOG** key flashes red

Step 2 Press the **Up** or **Down** key to select "MANUAL" or "YELP".

The following information appears on the screen.



The FOG key begins flashing.

Step 3 Press and hold the **PTT** key on the microphone.

The following information appears on the screen.



The LH-5000 stops sounding the warning signal until the **PTT** key is released.

Automatically Sending a warning signal

- Step 1** Press the **FOG** key on the front panel.
- Step 2** Press the **Down** key to select "UNDERWAY".

The following information appears on the screen.



- Step 3** Press the **ENT** key on the front panel to activate the automatic warning signal.

The FOG key lights red, and the following information appears on the screen.



2.12 Transmitting the Auxiliary Signal

- Step 1** Press the **ALL** key on the front panel.
- Step 2** Press the **MENU** key on the front panel.

Step 3 Press the **Up** or **Down** key to select "SOURCE" on the screen and press the **ENT** key.



Step 4 Press the **Down** key to select "AUX" and press the **ENT** key.



In AUX mode, all the intercom speakers output the signal from the external source such as audio player, etc.

2.13 Setting the Alarm Mode

The LH-5000 works as a burglar alarm by connecting an external switch to the ALARM terminals on the rear panel. When the alarm mode is enabled, both horn speakers are automatically selected. If an alarm is triggered, the LH-5000 sounds the alert for two minutes and stop for five minutes in cycle.

Enabling the alarm mode

Step 1 Press the **MENU** key on the front panel.

Step 2 Press the **Up** or **Down** key to select "ALARM" and press the **ENT** key.



Step 3 Press the **Down** key to select "ON" and press the **ENT** key.



The **BOTH** key glows red every four second, and the following information appears on the screen. Countdown will start.



After five minutes, the LH-5000 goes to "STAND BY" mode. Then it sounds alarm tone loudly for two minutes, and then pauses for five minutes. This cycle is repeated continuously.

Also the following information appears on the screen.



Disabling the alarm mode

Press any key except **ENT**, **Up**, or **Down** key on the front panel to exit the alarm mode.

2.14 Setting the Siren Mode

The LH-5000 in the siren mode sounds the warning signal such as YELP through both horn speakers, alerting nearby vessels of your presence and status. To interrupt the warning signal, press and hold the **PTT** key on the microphone and speak into it.

You can communicate with intercom speakers in the siren mode by choosing the specific one.

Step 1 Press the **MENU** key on the front panel.

Step 2 Press the **Up** or **Down** key to select "SIREN" and press the **ENT** key.



Step 3 Press the **Up** or **Down** key to select "ON" or "OFF" and press the **ENT** key.



- ON: The LH-5000 sounds the warning signal.
- OFF: The LH-5000 does not sound the warning signal.

Talking with a specific intercom speaker in the siren mode

Step 1 Press any key from **IC 1** to **IC 6** on the front panel.

A short tone sounds from the selected intercom speaker and the corresponding information appears on the screen.

Step 2 Press the **PTT** key on the microphone and speak into it.

Step 3 Release the **PTT** key to receive.

Step 4 After finishing your conversation, press the same selected key from **IC 1** to **IC 6** to return to the siren mode.

Talking with all intercom speakers in the siren mode

Step 1 Press and hold any key from **IC 1** to **IC 6** on the front panel for two seconds.

All keys from IC 1 to IC 6 light red and a short one sounds from all the intercom speakers.

Step 2 Press the **PTT** key on the microphone and speak into it.

Step 3 Release the **PTT** key to receive.

2.15 Setting the Key Beep

Step 1 Press the **MENU** key on the front panel.

Step 2 Press the **Up** or **Down** key to select "KEY BEEP" and press the **ENT** key.

Step 3 Press the **Up** or **Down** key to select "ON" or "OFF" and press the **ENT** key.

- **ON:** You hear the beep when pressing the key on the front panel.

- OFF: You do not hear the beep when pressing the key on the front panel.

2.16 Renaming the Intercom Station

Step 1 Press the **MENU** key on the front panel.

Step 2 Press the **Up** or **Down** key to select "RENAME IC" and press the **ENT** key.

Step 3 Press the **Up** or **Down** key to select the intercom station to be modified and press the **ENT** key.

Step 4 Press the **Up** or **Down** key to toggle the character at cursor position, i.e. letters, numbers, hyphen, or space, and then press the **ENT** key to confirm your selection.



Step 5 Press the **ENT** key to move the cursor position to the right and repeat Step 4 to change each character.

Step 6 Press the **MENU** key to finish.

You can press any key from **IC 1** to **IC 6** to view the modification.

2.17 Selecting the Speaker

Step 1 Press the **MENU** key on the front panel.

Step 2 Press the **Up** or **Down** key to select "SPEAKER" and press the **ENT** key.

Step 3 Press the **Up** or **Down** key to select "INTERNAL" or "EXTERNAL" and press the **ENT** key.

- INTERNAL: uses the built-in speaker.
- EXTERNAL: uses the external speaker.

2.18 Performing the Self-test

Step 1 Press the **MENU** key on the front panel.

Step 2 Press the **Up** or **Down** key to select "SELFTEST" and press the **ENT** key.

Step 3 Press the **Up** or **Down** key to select "EEPROM" or "SW VER." and press the **ENT** key.

- EEPROM: tests whether the EEPROM works properly.
- SW VER.: displays the software version.

2.19 Restoring the Factory Settings

Step 1 Press the **MENU** key on the front panel.

Step 2 Press the **Up** or **Down** key to select "RESET ALL" and press the **ENT** key.

The following information appears on the screen.

IF OK,
PRESS ENT

Step 3 Press the **ENT** key.

All your customized settings such as key backlighting are restored to factory settings.

The table below lists the factory setting.

No.	Function	Default Setting
1	DIMMER	Level 3
2	CONTRAST	Level 3
3	SOURCE	MIC
4	ALARM	OFF
5	SIREN	OFF
6	KEY BEEP	ON
7	RENAME IC	IC1 Name: IC1
		IC2 Name: IC2
		IC3 Name: IC3
		IC4 Name: IC4
		IC5 Name: IC5

No.	Function	Default Setting
		IC6 Name: IC6
8	SPEAKER	INTERNAL

3. Maintenance and Troubleshooting

3.1 Preventive Maintenance

Product Care

Do the following tasks monthly.

- Check all the cables. If the cable is damaged, replace it on time.
- Check connections. Re-tighten the cable if necessary.
- Measure the input voltage to be sure it is within the rated voltage (10.8 – 15.6 V DC).

Product Cleaning

- Clean up the dust and fine particles on the product surface and charging piece with a clean and dry lint-free cloth or a brush regularly.
- Do not use chemical preparations such as stain removers, alcohol, sprays or oil preparations, so as to avoid surface case damage.
- Make sure the product is completely dry before use.

3.2 Replacing the Fuse

If the LH-5000 cannot be powered on, the 15 A fuse inside the power cord may be blown. In this case, only the qualified technician is allowed to check and replace the fuse.

3.3 Troubleshooting

When the LH-5000 does not work properly, you can follow troubleshooting procedures to fix it. If the following solution cannot solve your problems, please contact your qualified technician for more technical support.

If...	Then...
The LH-5000 cannot be turned on,	Check whether the power cord is connected tightly. Ask the qualified technician to check whether the fuse is blown.
You cannot hear the voice from the intercom stations,	Rotate the LISTEN VOL knob clockwise to increase the volume.
The volume of intercom station is too low,	Rotate the HAILER VOL knob clockwise to increase the volume.

Specifications

General		
Dimensions (H×W×D)	1100×2200×108 mm	
Weight (with cable and knob/hanger)	1.59 kg	
Power Supply	10.8–15.6 V DC	
Power Consumption	Full Load (2 hailer& 6 intercoms)	≤11A (12V DC)
	Standard (1 hailer& 1 intercom)	≤5 A(12V DC)
	Standby & Backlight Level 3	≤280 mA (12V DC)
Audio		
Audio Output	Hailer Speaker	30 W, 8 Ω
	Intercom Speaker	5 W, 8 Ω
	External Speaker	5 W, 8 Ω
	Internal Speaker	2.5 W, 8 Ω
Input Impedance	Microphone	600±50 Ω

	Auxiliary	5.0±0.5 kΩ
Sensitivity	Microphone	13±3 mVrms (1 kHz)
	Auxiliary	775±50 mVrms (1 kHz)
Distortion	Hailer	≤10% (1 kHz/30 W)
	Intercom	≤10% (1 kHz/5 W)
S/N	Hailer	60 dB (1 kHz & A-weight)
	Intercom	60 dB (1 kHz& A-weight)
Frequency Response	Hailer	80 Hz–10 kHz at 3 dB
	Intercom	80 Hz–10 kHz at 3 dB
	Auxiliary	80 Hz–10 kHz at 3 dB
Horn Frequency	520 ± 50 Hz	
Environment		
Temperature	Operating: -15°C to 55°C (EN60945)	
	Storage: -30°C to +80°C	
Relative Humidity	95% at 40°C	
Waterproofing	IP67 (IEC 60529)	

**Note**

All specifications are tested according to applicable standards, and subject to changes without notice due to continuous development.

Packing List

Standard Supply

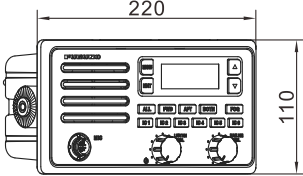
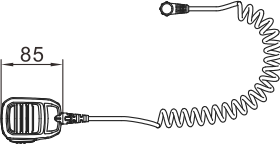
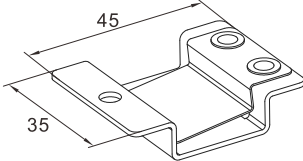
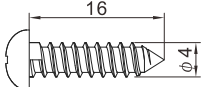
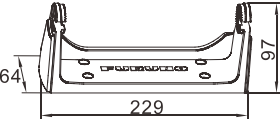
NAME	OUTLINE	DESCRIPTION	Q'TY
UNIT			
LOUDHAILER		LH-5000	1
MICROPHONE SET			
MICROPHONE		MIC-5000	1
MICROPHONE HANGER		/	1
TAPPING SCREW		/	3
ACCESSORIES			
HANGER		/	1

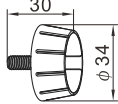
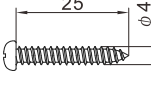
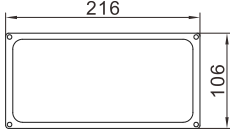
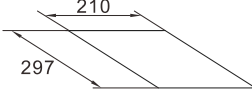
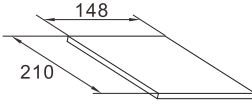
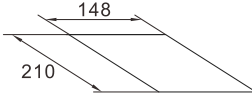
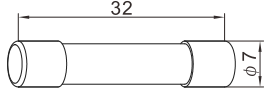
NAME	OUTLINE	DESCRIPTION	Q'TY
HANGER KNOB			2
TAPPING SCREW			4
FLUSH MOUNTING MATERIALS			
CUSHION			1
TEMPLATE			1
DOCUMENT			
OPERATOR'S MANUAL			1
Contents of Hazardous Substances or Elements of products			1
SPARE PARTS			
TUBE FUSE		250VAC 15A	2

Optional Supply

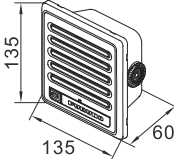
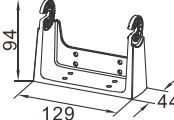
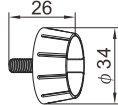
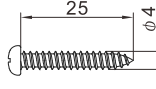
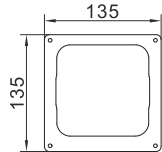
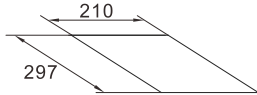
NAME	OUTLINE	DESCRIPTION	Q'TY
UNIT			
INTERCOM SPEAKER		ISP-5000	1
ACCESSORIES			
HANGER		/	1
HANGER KNOB		/	2
TAPPING SCREW		/	4
FLUSH MOUNTING MATERIALS			
CUSHION		/	1
TEMPLATE		/	1

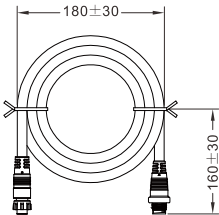
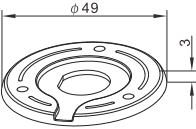
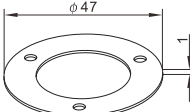
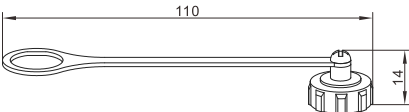
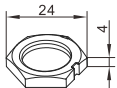
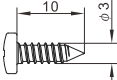
NAME	OUTLINE	DESCRIPTION	Q'TY
EX-CBL-LH5M			
EXTENDED CABLE		EX-CBL-LH5M	1
ACCESSORIES			
CABLE HOLDER		/	1
SEAL		/	1
WATERPROOF COVER		/	1
NUT		/	1
TAPPING SCREW		/	3

Outline Drawings

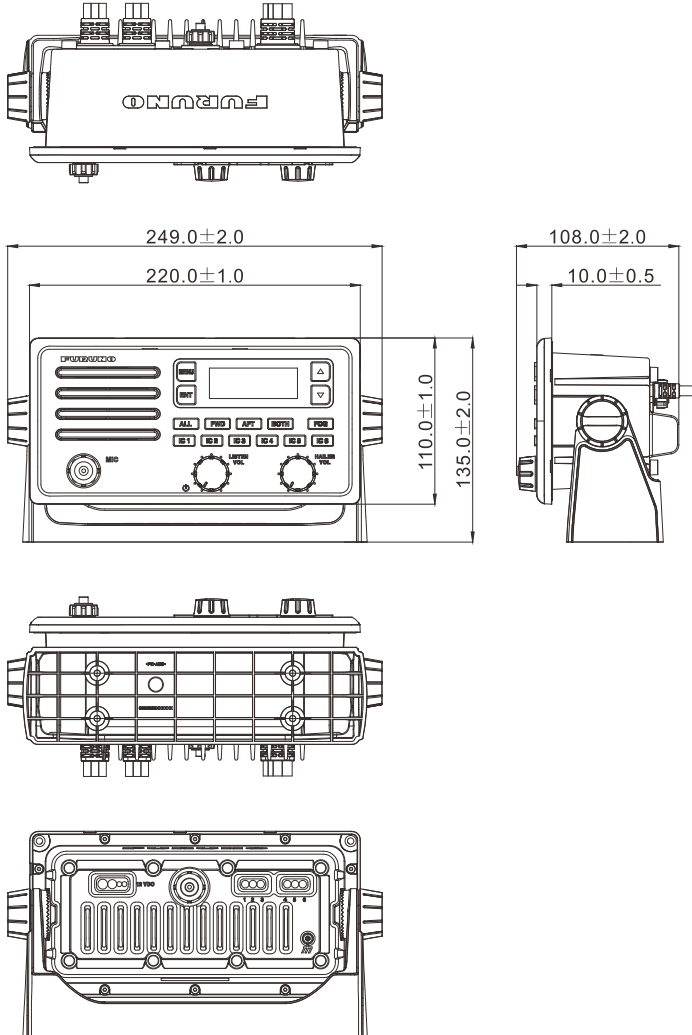

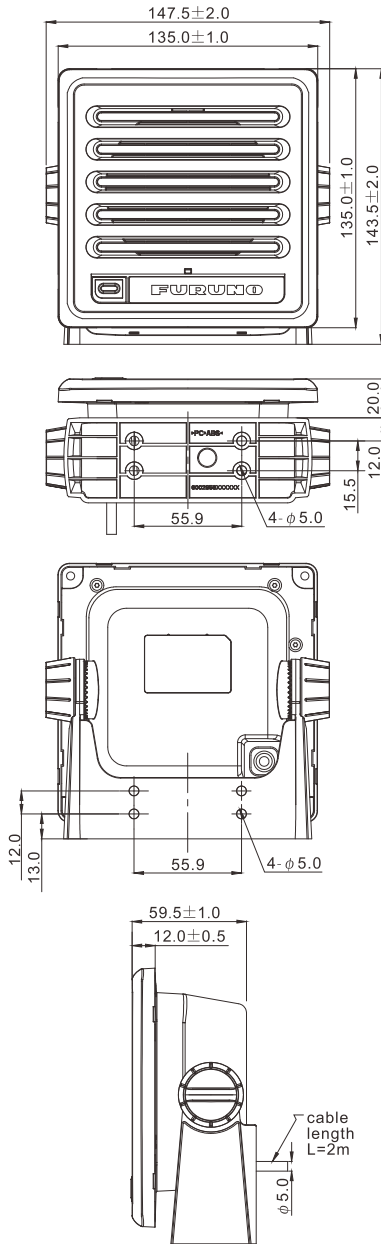

Service Space Information

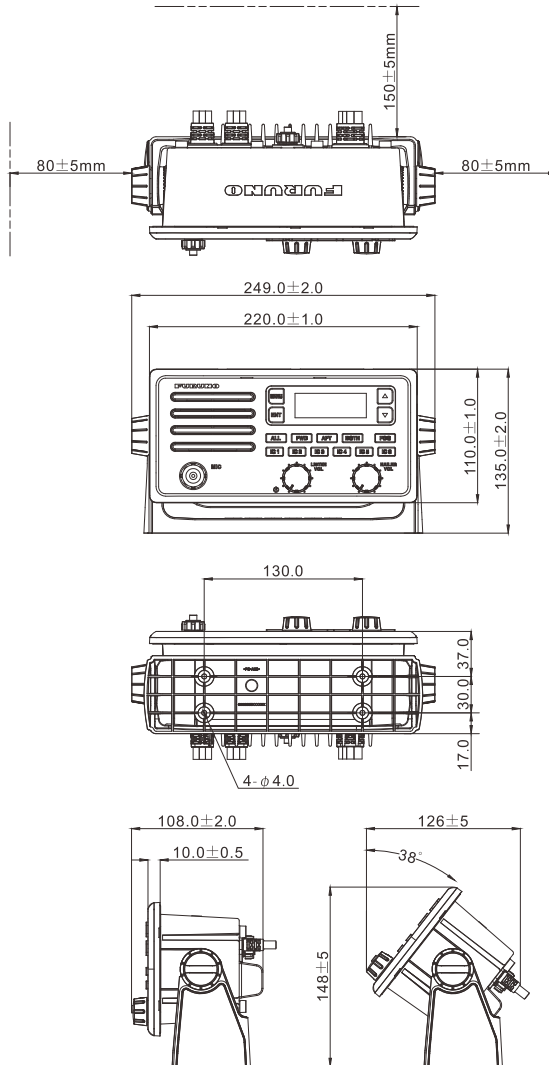

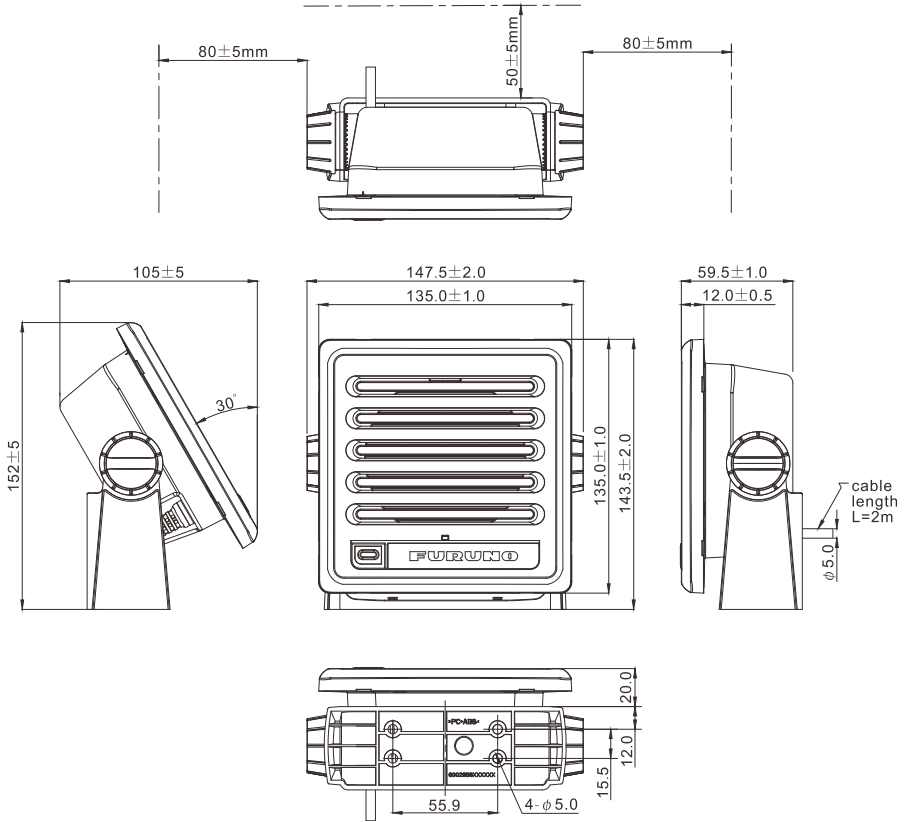

Interconnection

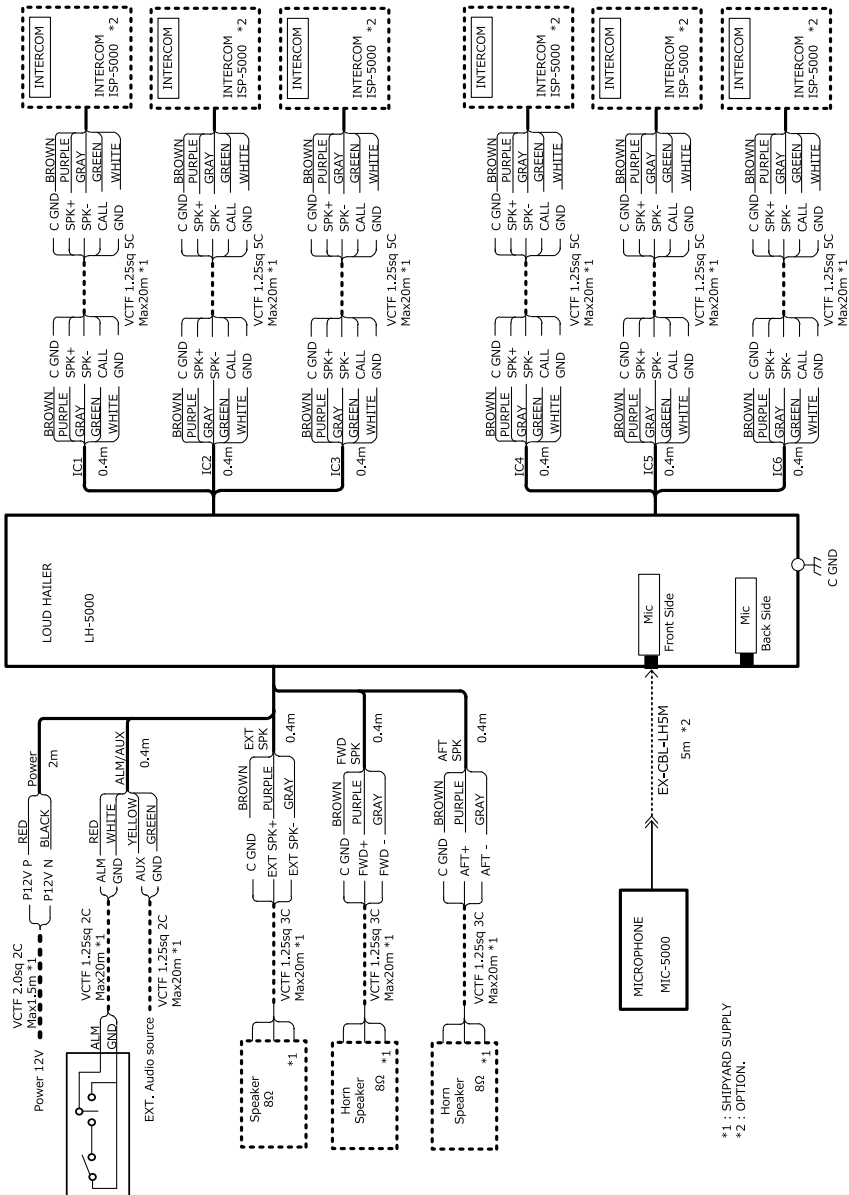

Menu Tree

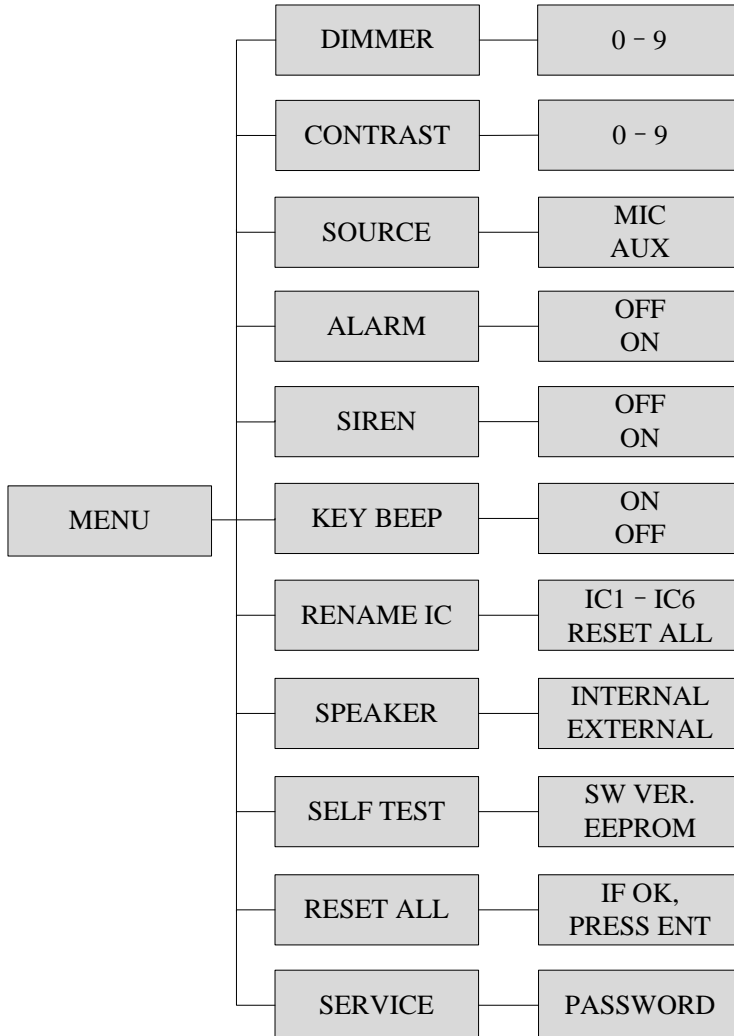

FURUNO

LH-5000 Flush Mount Template

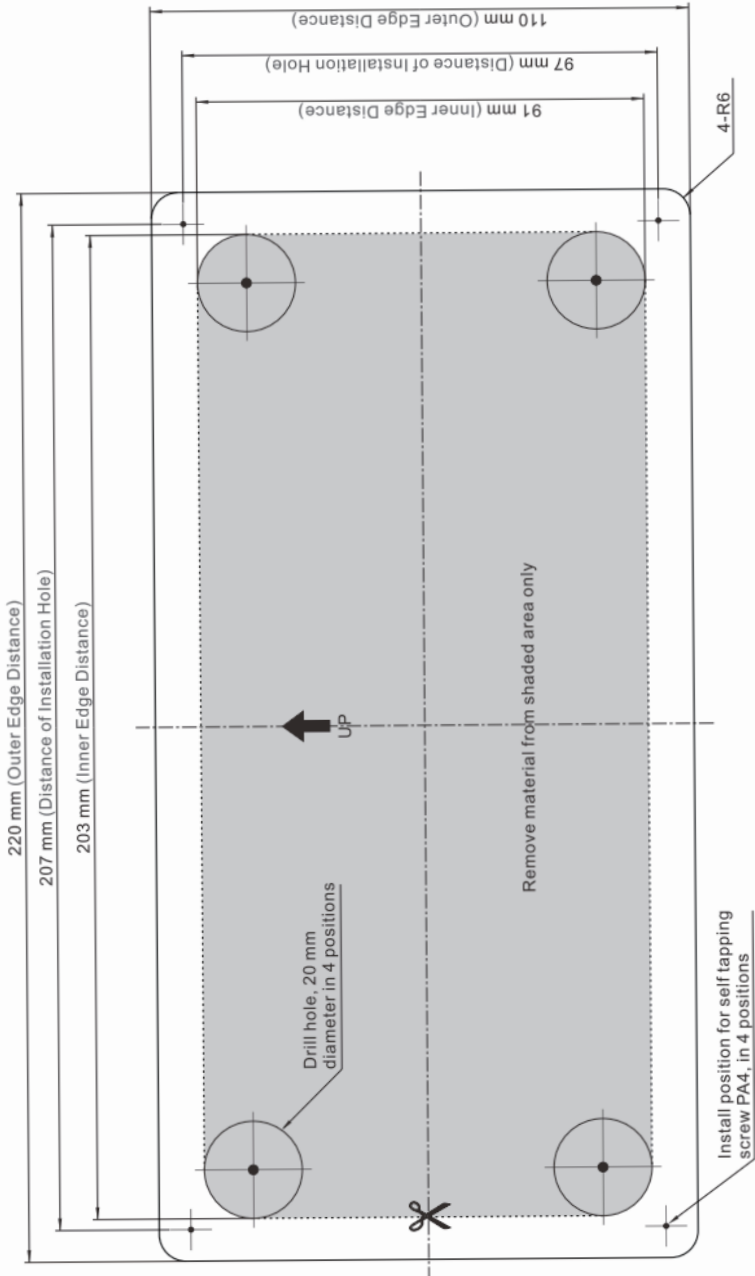

FURUNO

ISP-5000/SP-4800 Flush Mount Template

